

Eaton®
Quick Disconnect Couplings



Powering Business Worldwide

For over 50 years, Eaton has continued to manufacture and supply the highest performing and quality quick disconnect couplings globally for many different market segments including agriculture, construction, transportation, and fire and rescue just to name a few. Eaton's quality and performance have never been compromised when it comes to engineering and manufacturing its full line of quick disconnect couplings. From traditional industry standards to custom couplings for the next generation of emerging markets and new advanced technologies, Eaton continues to provide quick disconnect coupling solutions to meet your demands.

Custom Design Capability – One Application at a Time

Eaton continues the tradition of developing custom quick disconnect couplings for customers that need a product to perform above and beyond industry standards. Whether it is a custom coupling for the world's most powerful and sophisticated super computers that use electronics cooling or a self contained breathing apparatus coupling for first responders, Eaton has the ability to work directly with you on a solution. Contact Eaton to see how our dedicated and experienced design engineering team will work with you to develop a quick disconnect coupling solution.

Expanding the Product Line

The FD31, FD83, FD89-2000, FD96 and FD99 series quick disconnect coupling product lines provide Eaton customers with high performing fluid power solutions for traditional applications in the agriculture, construction, industrial and on-highway markets while expanding into new markets with customized solutions. The expanded line of quick disconnect couplings provide application solutions for electronics cooling and thermal management, off-shore and land based oil exploration, pharmaceutical, marine, chemical processing, hydraulic jack, portable ram, and mining applications. Most of the aforementioned couplings exhibit increased pressures and more extensive fluid compatibility options in order to operate in more complex applications. These couplings compliment our complete line of products that meet or exceed industry standards.



Custom Solutions	2
Overview	4
How to Order	5
Industry Applications	6
Safety Information	7
Fluid Compatibility	8
Fluid Transfer and Hydraulic	
FD35: 10,000 psi Arc Latch™	12
FD45 (Steel): ISO 7241/1 Series B Interchange	14
FD45 (Brass): ISO 7241/1 Series B Interchange.	17
FD45 (Stainless Steel): ISO 7241/1 Series B Interchange	20
FD48: Parker Bruning SM-250 Interchange.	23
FD49: NFPA Standard T3.20.15 HTMA Interchange	24
5100: Thread to Connect.	26
5600: ISO 7241/1 Series A Interchange.	30
FD86: Thread to Connect 5,000 psi Dry Break – High Impulse	35
FD89: ISO 16028 Interchange.	37
FD89 - 2000: 316 Stainless Steel ISO 16028 Interchange.	40
FD96: High Pressure Thread to Connect Flush Face (Connect under Pressure).	42
FD99: High Pressure Flush Face ISO 16028 Interchange	44
Hydraulic Farm	
FD72: Connect Under Pressure – Farm ISO 5675 Interchange	47
FD 70 & 76: Male Tip – Farm ISO 5675 Interchange	48
Diagnostics	
FD15: Oil Sampling Valve	49
FD90: Diagnostic Coupling SAEJ1502	51
Pressure Gauge Kit: FF14802	53
Special Applications	
FD14: Oil Drain Coupling	55
FD31: Enerpac Interchange	58
FD69: 10,000 psi Water Blast	59
FD83: Full Flow Dual Interlock.	61
Refrigerant	
5400: Low Air Inclusion Refrigerant	62
Air Couplings	
FD40: MIL-C-4109 Interchange.	66
FD41: ARO 210 Interchange	68
FD43: MIL-C-4109 Interchange.	69
Competitor Cross Reference	71

Eaton Quick Disconnect Couplings are available in numerous configurations to meet all of your application needs. Eaton Quick Disconnects are available in traditional fluid power applications while expanding into new sustainable next generation markets. Increased pressures, fluid compatibility options and improved performance highlight the Eaton Quick Disconnect Coupling product line.

Markets

- Transportation
- Utility
- Food and Beverage
- Chemical Processing
- Marine
- Hydraulics
- Pharmaceuticals/Medical
- Electronics
- Oil and Gas
- Mining
- Industrial Plants
- Construction
- Agriculture
- Forestry
- Marine and Defense

Applications

- Hydraulic Jack
- Portable Hydraulic Rams
- Electronic Liquid Based Cooling
- Thermal Management Systems
- Industrial Fluid Transfer
- Hydraulic Fluid Transfer
- Chemical Processing
- Pharmaceutical Transfer
- Oil Field
- Agricultural Equipment
- High Impulse Hydraulics
- Chemical Transfer
- Construction Equipment



Off-Shore



Mining



Agriculture



Industry

How to Order

Eaton Quick Disconnect Couplings can be ordered as separate halves. For special packaging, contact Eaton. Standard coupling part numbers are described below.

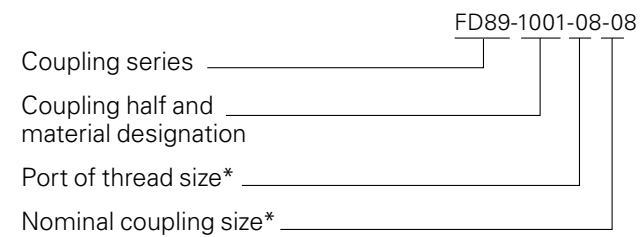

* Size designations are represented in 16ths of an inch, i.e., 06 = 6/16 or 3/8 inch

Dimensions

Dimensions in this catalog are for reference only. Actual dimensions may vary from those shown.

Coupling Identification

Generally, the coupling series or complete part number will be stenciled on the coupling body.

Caution:

The user should observe carefully the precautions listed in this catalog. These include selection of seals and body materials for fluid compatibility and recommendations on the selection of quick disconnect couplings. In addition, care should be taken not to exceed the maximum operating pressures listed for each coupling size and type shown in the physical characteristics table for each coupling. Because of possible variations in machining tolerances, quality control, inspection and quality assurance, Eaton coupling halves should not be used with coupling halves supplied by other manufacturers except where such use is approved for a particular coupling as noted in this catalog.

For Technical Assistance Contact:

Eaton's Hydraulics Group
 14615 Lone Oak Road
 Eden Prairie, MN 55344
 Phone: 952-937-9800
 Fax: 952-974-7722



Construction



Forestry

Industry applications are provided for each coupling indicating where it is typically used. But remember, a coupling can be used in any industry, provided it meets the established application requirements.

Agriculture



FD14, FD42, FD48, 5400, 5600, FD70, FD72, FD76, FD89, FD90, FD96

Electronics Cooling



FD45 (stainless), FD45 (brass), 5100, 5400, FD83, FD89-2000 (stainless)

Marine and Military



FD14, FD15, FD35, FD45 (stainless), FD45 (brass), 5100, 5400, 5600, FD69, FD86, FD90, FD89, FD89-2000 (stainless), FD99, FD96

Pharmaceutical/Medical



FD15, FD45 (brass), FD45 (stainless), 5400, FD83, FD89-2000 (stainless)

Chemical Transfer



FD45, FD49, 5100, 5400, FD45 (stainless), FD83, FD89-2000 (stainless)

Food and Beverage



FD15, FD45 (stainless), FD89-2000 (stainless)

Industrial Plants/Processing



FD14, FD31, FD35, FD40, FD41, FD43, FD45 (steel), FD45 (brass), FD45 (stainless), FD48, FD49, 5100, 5600, FD69, FD86, FD89, FD89-2000 (stainless), FD96, FD99

Construction/Mining



FD14, FD15, FD35, FD40, FD41, FD42, FD43, FD45 (steel), FD48, FD49, 5100, 5400, 5600, FD69, FD86, FD89, FD90, FD96, FD99

Forestry



FD14, FD15, 5600, FD86, FD89, FD96, FD99

Transportation



FD14, FD15, FD42, FD45 (steel), FD45 (brass), 5100, 5400, 5600, FD90, FD96, FD89-2000 (stainless)

Oil and Gas (Offshore/Oil Patch)



FD15, FD35, FD45 (stainless), FD45 (brass), 5100, 5600, FD86, FD90, FD89, FD89-2000 (stainless)

Maintenance/Repair Operations



FD14, FD31, FD40, FD41, FD43, FD45 (steel), FD45 (brass), FD49, 5100, 5600, FD69, FD89, FD96

Utility/Aerial Life/Material Handling



FD14, FD15, FD35, FD45 (steel), FD49, 5100, FD86, FD89, FD90, FD96, FD99

Safety Information for Eaton Quick Disconnect Couplings

1.0 General Instructions.

1.1 Scope. The scope of this safety bulletin is to warn against improper selection, use, installation, etc. of Eaton coupling products.

1.2 Distribution. A copy of this safety bulletin should be distributed to all individuals responsible for using and/or selecting Eaton coupling products.

1.3 Fail-Safe. Design all systems and equipment for failsafe operation such that failure of any component does not result in personal injury and/or property damage.

1.4 User Responsibility. It is the sole responsibility of the user to select and determine that the Eaton product is compatible with the end use application. The user is responsible for reading and following this safety bulletin as well as any instructions or literature on the Eaton product being used. The user must provide necessary product warnings for Eaton couplings products, used with systems or equipment, to the operators of the systems or equipment.

1.5 Usage with other Manufacturers' Products. When using Eaton coupling products with other manufacturers' adapters, hoses, etc., do not exceed the lowest pressure rating of any of the components being used or rupture may result.

2.0 Selection of Eaton Couplings.

2.1 Pressure. Ensure that the maximum operating pressure of the system or equipment does not exceed the rated operating pressure of the Eaton coupling product or rupture may result.

2.2 Fluid Compatibility. Verify that all components (seals, metals, etc.) are compatible with the fluid being conveyed. Failure to do so may result in high speed fluid discharge and/or leakage of fluids which may be flammable, toxic, at extreme temperatures, or otherwise harmful.

2.3 Temperature. Ensure that the maximum operating temperature of the system or equipment does not exceed the rated operating temperature of the Eaton coupling product (including seals) or rupture may result.

2.4 Coupling Size. Use properly sized couplings such that there is not a large pressure drop across them thus avoiding system damage due to excessive heat generation or failure of internal components.

2.5 Sleeve Lock. Use sleeve locks or threaded couplings where there is the possibility of accidental disconnection. Failure to utilize sleeve locks or threaded couplings in these applications may result in hose whip, expelled components, high speed fluid discharge, system damage, or leakage of fluids which may be flammable, toxic, at extreme temperatures, or otherwise harmful.

2.6 Connect or Disconnect Under Pressure.

If connection and/or disconnection of couplings under pressure is a requirement, only use couplings designed for connection/disconnection under pressure. Failure to utilize this type of coupling in that application may result in hose whip, expelled components, high speed fluid discharge, and/or system damage. Be certain not to confuse the rated operating pressure with the rated connect/disconnect under pressure.

2.7 Environment. Ensure that Eaton couplings are compatible with the surrounding environment. The surrounding environment may be heat, salt water, moisture, chemicals, and the like. Failure to protect against an adverse environment may cause system damage, premature failure, and/or leakage of fluids which may be flammable, toxic, at extreme temperatures, or otherwise harmful.

2.8 External Loads. Avoid any external loads such as side loads, tensile loads, vibration, etc. Failure to do so may result in accidental disconnection, premature failure, system damage, and/or leakage of fluids which may be flammable, toxic, at extreme temperatures, or otherwise harmful.

2.9 Welding & Brazing. Extreme heating of plated products above +450°F (+232°C) such as welding, brazing, baking, etc., where the plating is burned off, may result in the release of deadly gases.

3.0 Installation of Eaton Couplings.

3.1 Inspection of Product. Prior to installation, ensure that the Eaton product meets all of the requirements of the system and/or equipment it is to be used on. Ensure you have the correct part number, function test the coupling by connecting it with a mating half. The function test should result in smooth, non-binding operation or premature failure may result.

3.2 Cleanliness. Use end caps and plugs to reduce the risk of system contamination or damage to critical sealing surfaces. Failure to do so may result in leakage of fluids which may be flammable, toxic, at extreme temperatures, or otherwise harmful. Caps and plugs are not a secondary seal unless explicitly noted.

3.3 Location. Place Eaton couplings in a safe location such as not to expose the user to personal injury (slippage, tripping, falling, etc.) during installation, connection, disconnection and maintenance.

4.0 Product Maintenance. A maintenance schedule should be put in place to ensure that Eaton couplings are functioning properly.

4.1 Inspection. Visually inspect to ensure that there is no leakage, cracked components, corrosion build-up, contamination build-up, wear, etc. If any abnormality is encountered, the coupling should be replaced immediately.

Fluid Compatibility

This chart indicates the suitability of various elastomers and metals for use with fluids to be conveyed. It is intended for use with Eaton couplings and should not be used to determine compatibility for other products. It is intended as a guide only and is not a guarantee. Final selection of the proper seal or material of metal components is further dependent on many factors including pressure, fluid and ambient temperature, concentration, duration of exposure, etc.

How to Use the Chart

- Both the elastomer and the metal must be considered when determining suitability of combination for a coupling.
- Locate the fluid to be conveyed and determine the suitability of the elastomeric and metal components according to the resistance rating shown for each.
- Dimensional and operation specifications for each coupling can be found on the catalog pages.
- Information on seal options for couplings, and how to specify them, are shown in the respective sections of this catalog.
- Be sure to check the table below for maximum operating temperature range of the elastomer desired.
- For further details on the products shown in this catalog, and their applications, consult your Eaton Sales Representative or Eaton Technical Support.
- Coupling component materials may differ from body material. Refer to specific catalog pages.

This charts below are intended for reference use only. The information in this chart pertains strictly to material compatibility and is not intended to be used as an application guide

E=Excellent
G=Good
C=Conditional
U=Unsatisfactory

Fluid	Seals				Metal			
	Buna-N	Neoprene	EPR/EPDM	Viton	Steel	Brass	Stainless Steel	Aluminum
Acetaldehyde	U	C	C	U	G	E	E	E
Acetic Acid, 10%	U	U	E	G	U	U	C	C
Acetic Acid, Glacial	U	U	C	U	U	U	C	C
Acetone	U	U	G	U	E	E	E	E
Acetophenone	U	U	E	U	E	E	E	C
Acetyl Acetone	U	U	G	U	U	C	C	C
Acetyl Chloride	U	U	U	E	C	C	C	U
Acetylene (1)	G	U	G	E	E	E	E	E
Air, Hot (Up to +160°F)	E	E	E	E	E	E	E	E
Air, Hot (161°F – 200°F)	C	G	E	E	E	E	E	E
Air, Hot (201°F – 300°F)	U	U	G	E	E	E	E	E
Air Wet, below 160°F	E	E	E	E	U	G	E	E
Aluminum Chloride, 10% aq	E	E	E	E	U	U	U	U
Aluminum Fluoride, 10% aq	E	E	E	E	U	U	U	E
Aluminum Nitrate, 10% aq	E	E	E	E	U	U	C	C

Seal Elastomer Data*

Seal Elastomer	Application Specification	Max. Operation Temperature Range
Buna-N	none	-40°F to +250°F (-40°C to +121°C)
Neoprene	none	-65°F to +212°F (-54°C to +100°C)
EPR (Ethylene Propylene Rubber)	none	-65°C to +300°F (-54°C to +149°C)
Viton	MIL-R-25897	-15°F to +400°F (-29°C to +204°C)

* For reference only, based on Eaton recommended temperatures. Contact Eaton technical support for further information.

Resistance Rating Key

E = Excellent – Fluid has little or no effect
G = Good – Fluid has minor to moderate effect
C = Conditional – Service conditions should be described to Eaton for determination of suitability for application
U = Unsatisfactory

The differences between ratings “E” and “G” are relative. Both indicate satisfactory service. Where there is a choice, the materials rated “E” may be expected to give better or longer service than those rated “G”

Fluid	Seals				Metal			
	Buna-N	Neoprene	EPR/EPDM	Viton	Steel	Brass	Stainless Steel	Aluminum
Aluminum Sulfate, 10% aq	E	E	E	E	U	C	E	C
Alums, 10% aq	E	E	E	E	U	C	E	C
Ammonia, Cold	E	E	E	U	E	U	E	E
Ammonia, Hot	U	G	G	U	E	U	E	E
Ammonia, Anhydrous	G	G	E	U	E	U	E	E
Ammonia, Aqueous	E	E	E	U	E	U	E	E
Ammonium Carbonate, 10% aq	U	E	E	U	C	U	C	C
Ammonium Chloride, 10% aq	E	E	E	U	U	U	C	U
Ammonium Hydroxide, 10% aq	C	C	E	C	G	U	C	C
Ammonium Nitrate, 10% aq	E	G	E	U	G	U	G	G
Ammonium Phosphate, 10% aq	E	E	E	-	U	C	G	U
Ammonium Sulfate/Sulfide, 10% aq	E	E	E	U	U	U	G	U
Amyl Acetate	U	U	G	U	E	E	E	E
Amyl Alcohol	G	C	E	G	G	G	E	U
Aniline, Aniline Oil	U	U	G	U	E	U	E	G

Fluid Compatibility

E=Excellent
G=Good
C=Conditional
U=Unsatisfactory

Fluid	Seals				Metal			
	Buna-N	Neoprene	EPR/EPDM	Viton	Steel	Brass	Stainless Steel	Aluminum
Aniline Dyes	U	G	G	G	U	C	G	C
Asphalt, < 200°F	G	C	U	E	E	G	E	C
IRM 901 Oil	E	E	C	E	E	E	E	E
IRM 902 Oil	E	G	U	E	E	E	E	E
IRM 903 Oil	E	C	U	E	E	E	E	E
Automatic Trans. Fluid	E	C	U	E	E	E	E	E
Barium Chloride, 10% aq	E	E	E	E	U	G	G	G
Barium Hydroxide, 10% aq	E	E	E	E	G	U	G	U
Barium Sulfide, 10% aq	E	E	E	E	C	U	G	U
Benzene, Benzol	U	U	U	E	G	E	E	G
Benzoic Acid	U	U	U	E	U	G	G	G
Benzyl Alcohol	U	G	G	E	E	G	E	G
BioDiesel (<B20)	G	C	U	E				
BioDiesel (>B20)	G	C	U	E				
Black Sulfate Liquor	C	C	C	E	E	C	E	U
Blast Furnace Gas	U	U	U	E	E	C	E	U
Borax, 10% aq	G	G	E	E	E	E	E	G
Boric Acid, 10% aq	G	G	G	E	U	G	C	C
Brine	E	G	E	E	U	G	G	U
Bromine, Dry	U	U	U	E	U	C	U	C
Butane	E	C	U	E	E	E	E	E
Butyl Acetate	U	U	G	U	E	E	E	E
Butyl Alcohol	E	E	G	E	G	G	G	G
Butyl Cellosolve	U	U	G	U	E	E	E	E
Butylene (Butene)	C	U	U	E	E	E	E	E
Butyl Stearate	G	U	U	E	G	G	G	G
Butyraldehyde	U	U	G	U	E	E	E	E
Calcium Acetate, 10% aq	G	G	E	U	G	G	G	C
Calcium Bisulfate, 10% aq	E	E	U	E	U	C	C	U
Calcium Chloride, 10% aq	E	E	E	E	G	G	G	C
Calcium Hydroxide, 10% aq	E	E	E	E	G	G	G	U
Calcium Hypochlorite, 10% aq	U	U	E	E	U	G	C	U
Calcium Nitrate, 10% aq	E	E	E	E	G	G	G	G
Carbitol	G	G	G	E	E	E	E	E
Carbolic Acid (Phenol)	U	U	G	E	U	E	E	-
Carbonic Acid	G	E	E	E	U	C	E	G
Carbon Dioxide, Dry Gas	G	G	E	E	E	E	E	E
Carbon Disulfide	U	U	U	E	G	G	G	E
Carbon Monoxide	G	G	E	E	E	E	E	E
Carbon Tetrachloride	U	U	U	E	U	G	G	U
Castor Oil	E	E	G	E	E	E	E	E
Cellosolve Acetate	U	U	G	U	U	U	E	G
China Wood Oil (Tung Oil)	G	G	U	E	E	G	E	E
Chlorine Gas, Dry	U	U	U	G	C	C	C	C
Chloroacetic Acid	U	U	G	U	U	U	U	U
Chloroacetone	U	U	E	U	G	G	G	U
Chlorobenzene	U	U	U	G	G	G	G	G
Chloroform	U	U	U	E	G	G	G	G
O-Chlorophenol	U	U	U	E	G	G	G	U
Chosulfonic Acid	U	U	U	E	G	U	G	G
Chrome Plating Solution	U	U	G	E	C	U	U	U

Fluid	Seals				Metal			
	Buna-N	Neoprene	EPR/EPDM	Viton	Steel	Brass	Stainless Steel	Aluminum
Chromic Acid	U	U	C	E	C	U	U	U
Citric Acid	E	E	E	E	C	C	C	C
Coke Oven Gas	U	U	U	E	E	C	E	U
Copper Chloride, 10% aq	E	E	E	E	U	U	U	U
Copper Cyanide, 10% aq	E	E	E	E	E	U	G	U
Copper Sulfate, 10% aq	E	E	E	E	U	C	G	U
Cotton Seed Oil	E	G	C	E	E	E	E	E
Creosote (Coal Tar)	G	C	U	E	E	C	E	E
Crude Oil	E	G	U	E	G	U	G	U
Cyclohexanol	E	G	U	E	E	E	E	C
Cyclohexanone	U	U	G	U	E	E	E	C
Detergent/Water Solution	E	E	E	E	G	E	E	E
Diacetone Alcohol (Acetol)	U	U	E	U	E	E	E	E
Dibenzyl Ether	U	U	G	U	G	G	G	G
Diesel Oil	E	C	U	E	E	E	E	E
Diethylamine	G	G	G	U	E	U	E	-
Diethyl Phthalate (DOP)	U	U	G	G	E	E	E	E
DOT #3 / #4 Brake fluid	C	U	E	U	E	C	E	E
Dowtherm A&E	U	U	U	E	G	U	E	E
Ethyl Alcohol (Ethanol)	E	E	E	E	E	E	E	G
Ethyl Acetate	U	U	G	U	E	E	E	E
Ethyl Benzene	U	U	U	E	E	G	G	G
Ethyl Cellulose	G	G	G	U	E	G	G	G
Ethyl Chloride	U	U	U	E	E	E	E	G
Ethylene Dichloride	U	U	U	G	G	C	G	G
Ethylene Glycol	E	E	E	E	U	C	E	E
Ferric Chloride, 10% aq	E	G	E	E	U	U	U	U
Ferric Nitrate, 10% aq	E	E	E	E	U	U	G	U
Ferric Sulfate, 10% aq	G	G	G	E	U	U	E	U
Formaldehyde	C	C	G	G	E	E	E	G
Formic Acid	C	G	E	U	U	C	C	C
Fuel Oil	E	C	U	E	E	E	E	E
Furfural	C	C	G	U	G	G	G	G
Gallic Acid, Solution	G	G	G	E	U	-	G	C
Gasoline	E	U	U	E	E	E	E	E
Gasohol	G	U	U	E	E	E	E	G
Glycerine/Glycerol	E	E	E	E	E	G	E	E
Green Sulfate Liquor	G	G	E	E	U	U	E	U
Helium (1)	E	E	E	E	E	E	E	E
Heptane	E	G	U	E	E	E	E	E
Hexaldehyde	U	G	G	U	G	G	E	E
Hexane	E	G	U	E	E	E	E	E
Hydraulic Oils, petroleum based	G	C	U	E	E	E	E	E
Ester Blend	E	U	U	E	E	E	E	E
Phos. Ester/Petroleum Blend	U	U	U	C	E	E	E	E
Silicone Oils	E	E	E	E	E	E	E	E
Straight Petroleum Base	E	C	U	E	E	E	E	E
Straight Phosphate Ester	U	U	G	C	E	E	E	E
Water Glycol	E	E	E	E	E	E	E	G
Water Petroleum Emulsion	E	G	U	E	C	E	E	G
Hydrobromic Acid	U	U	E	E	E	U	E	E

Fluid Compatibility

E=Excellent
G=Good
C=Conditional
U=Unsatisfactory

Fluid	Seals				Metal			
	Buna-N	Neoprene	EPR/EPDM	Viton	Steel	Brass	Stainless Steel	Aluminum
Hydrochloric Acid, Cold	U	U	G	E	U	U	U	U
Hydrocyanic Acid	C	C	E	E	E	E	G	E
Hydrofluoric Acid	U	U	C	U	U	U	U	U
Hydrofluorosilic Acid	G	G	E	E	U	U	U	U
Hydrogen	E	E	E	E	E	E	E	E
Hydrogen Peroxide	G	G	G	E	U	U	G	E
Hydrogen Sulfide, Dry	U	G	E	U	E	G	G	G
Isocyanate	U	U	G	E	G	-	G	-
Iso Octane	E	G	U	E	E	E	E	E
Isopropyl Acetate	U	U	G	U	E	-	E	E
Isopropyl Alcohol	G	G	E	E	E	E	E	G
Isopropyl Ether	G	U	U	U	G	G	G	-
JP-4, JP-5	E	U	U	E	E	E	E	E
Kerosene	E	U	U	E	E	E	E	E
Lacquer/Lacquer Solvents	U	U	U	U	U	E	E	E
Lime Sulfur	U	E	E	E	G	U	G	-
Linseed Oil	E	G	U	E	E	E	E	E
LPG	E	G	U	E	E	E	E	E
Magnesium Chloride, 10% aq	E	E	E	E	E	C	C	G
Magnesium Hydroxide, 10% aq	G	G	E	E	E	G	E	G
Magnesium Sulfate, 10% aq	E	E	E	E	E	E	E	E
Maleic Acid	U	U	U	E	E	G	G	G
Maleic Anhydride	U	U	U	E	G	U	E	G
Malic Acid	G	G	U	G	U	-	E	G
Mercuric Chloride	E	E	E	E	U	U	U	U
Mercury	E	E	E	E	E	U	U	U
Methanol	G	G	E	U	G	G	E	C
Methyl Bromide	G	U	U	E	E	E	G	U
Methyl Chloride	U	U	U	E	E	E	E	U
Methyl Butyl Ketone	U	U	E	U	E	E	E	-
Methyl Ethyl Ketone	U	U	E	U	G	G	G	G
Methylene Chloride	U	U	U	G	G	G	G	G
Methyl Isobutyl Ketone	U	U	U	U	G	G	G	G
Methyl Isopropyl Ketone	U	U	U	U	G	G	G	G
Methyl Salicylate	U	U	C	U	E	G	G	E
MIL-L-2104	E	G	U	E	E	E	E	-
MIL-H-5606	E	G	U	E	E	E	E	E
MIL-H-6083	E	E	U	E	E	E	E	-
MIL-L-7808	G	U	U	E	G	G	E	-
MIL-L-23699	G	U	U	E	E	E	E	E
MIL-H-46170	E	G	U	E	E	E	E	-
MIL-H-83282	E	U	E	E	E	E	E	-
Mineral Oils	E	C	U	E	E	E	E	E
Naphtha	C	U	U	E	-	-	-	-
Naphthalene	U	U	U	E	E	G	E	G
Naphthenic Acid	C	U	U	E	-	G	E	G
Natural Gas	E	E	U	E	G	G	G	G
Nickel Acetate, 10% aq	C	C	E	G	G	C	E	G
Nickel Chloride, 10% aq	E	G	E	E	U	U	G	U
Nickel Sulfate, 10% aq	E	E	E	E	U	G	E	U
Nitric Acid, to 10%	U	U	U	E	U	U	E	U

Fluid Compatibility

E=Excellent
G=Good
C=Conditional
U=Unsatisfactory

Fluid	Seals				Metal			
	Buna-N	Neoprene	EPR/EPDM	Viton	Steel	Brass	Stainless Steel	Aluminum
Nitric Acid, over 10%	U	U	U	G	U	U	E	C
Nitrobenzene	U	U	U	G	E	G	E	E
Nitrogen	E	E	E	E	E	E	E	E
Octyl Alcohol	E	E	E	E	E	E	E	E
Oleic Acid	U	U	C	G	C	E	G	C
Oleum, fuming sulfuric acid	U	U	U	E	E	E	E	E
Ortho-Dichlorobenzene	U	U	U	E	G	G	G	G
Oxalic Acid, 10% aq	G	G	E	E	U	C	C	C
Oxygen	-	-	E	E	G	G	G	G
Palmitic Acid	E	G	G	E	G	-	E	G
Para-Dichlorobenzene	U	U	U	E	G	G	G	G
Pentane	E	E	U	E	G	G	G	E
Perchloric Acid	E	G	G	E	U	U	U	U
Perchloroethylene	U	U	U	E	C	G	G	G
Petroleum Base Oils	E	G	U	E	E	E	E	E
Phenol (Carbolic Acid)	U	U	G	E	U	E	E	E
Phosphate Ester	U	U	G	C	E	E	E	E
Phosphoric Acid 20%	U	U	G	E	U	E	U	C
Phosphorous Trichloride	U	U	E	E	C	U	C	E
Potassium Acetate, 10% aq	G	G	E	U	C	G	C	U
Potassium Chloride, 10% aq	E	E	E	E	E	C	E	U
Potassium Cyanide, 10% aq	E	E	E	E	C	U	G	U
Potassium Dichromate, 10% aq	E	E	E	E	C	C	C	C
Potassium Hydroxide, to 10%	G	G	E	G	G	G	G	U
Potassium Hydroxide, over 10%	C	C	E	U	G	G	G	U
Potassium Nitrate, 10% aq	E	E	E	E	G	G	E	G
Potassium Sulfate, 10% aq	E	E	E	E	-	-	-	-
Propane (Liquified)	C	G	-	E	E	E	E	E
Propyl Acetate	U	U	G	U	E	-	E	E
Propyl Alcohol	E	E	E	E	E	E	E	E
Propylene	U	U	U	E	E	E	E	E
Rapeseed oil (B100)	G	C	U	E				
Refrigerant R-12	G	E	C	E	E	E	E	E
Refrigerant R-13	G	E	C	E	E	E	E	E
Refrigerant R-22	U	E	C	U	E	E	E	E
Refrigerant R-134a	E	C	G	U	E	E	E	E
Sewage	E	E	E	E	G	G	G	G
Silicone Oils	E	E	E	E	E	E	E	E
Soap (Water Solutions)	E	E	E	E	E	E	E	U
Sodium Acetate, 10% aq	G	G	E	U	E	E	G	E
Sodium Bicarbonate, 10% aq	E	E	E	E	G	G	E	G
Sodium Borate, 10% aq	E	E	E	E	E	E	E	G
Sodium Carbonate, 10% aq	E	E	E	E	E	G	E	U
Sodium Chloride, 10% aq	E	E	E	E	U	C	C	C
Sodium Cyanide, 10% aq	E	E	E	E	E	-	C	U
Sodium Hydroxide, to 10%	U	G	E	E	C	G	C	U
Sodium Hydroxide, over 10%	U	U	G	E	C	C	C	U
Sodium Hypochlorite, 10% aq	C	C	E	C	U	U	U	U
Sodium Metaphosphate, 10% aq	E	E	E	E	E	G	G	U
Sodium Nitrate, 10% aq	G	G	E	-	E	C	E	E
Sodium Perborate, 10% aq	G	G	E	E	C	U	C	U

FD35 Series

10,000 psi Arc Latch™



The FD35 Series Arc Latch™ design has a greater surface contact area for long surface life in rugged high pressure applications. The maximum operating pressure is 10,000 psi.

Product Features

- Safety sleeve lock prevents accidental disconnection
- Heat treated and plated steel for greater wear and corrosion resistance
- Standard seal material – Viton
- Heavy duty back-up ring prevents O-ring extrusion
- Self-sealing poppet valves provide excellent high and low pressure sealing
- Standard body material – High resistance carbon steel with zinc trivalent chromate plating

Physical Characteristics

Body Size	Max. Operating Pressure		Min. Burst Pressure		Vacuum Connected Only	Rated Flow	Air Inclusion	Fluid Loss
	bar	(psi)	bar	(psi)	(in./Hg)	L/min (gpm)	cc. max.	cc.max.
3/8	700	(10,000)	2,800	(4,000)	28	8 (2)	0.50	0.50

Applications

- 10,000 psi hydraulic applications
- Hydraulic tool
- Hydraulic ram and work loading



Flow Data

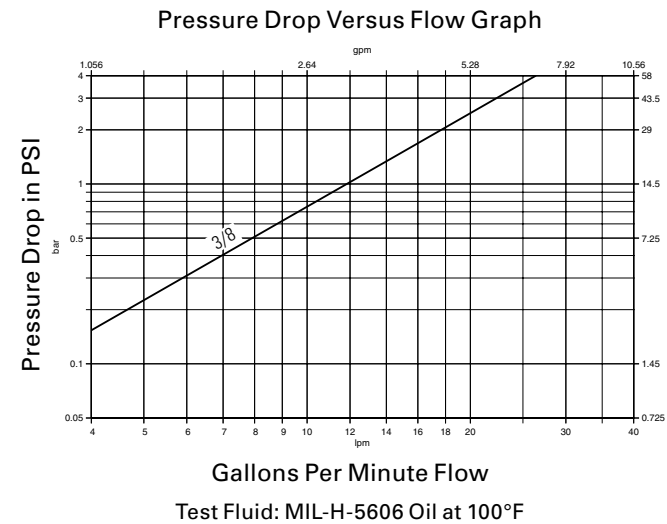

FD35 Series

10,000 psi Arc Latch™

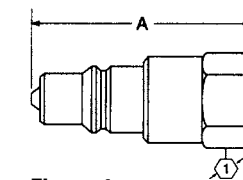

Figure 1

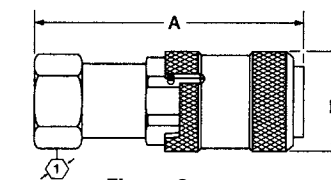

Figure 2

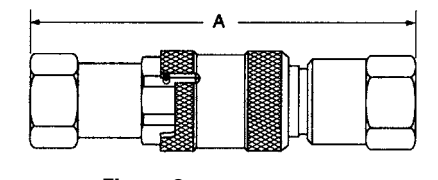

Figure 3

Dimensions (Female NPT, Valved)

Part Number Buna-N	Coupling Type	Body Size	Port Size	Thread	Type	Fig.	Dimensions					
							A		B		Hex Ⓛ	
							mm	(in)	mm	(in)	mm	(in)
FD35-1002-06-06	Male	3/8	3/8	3/8-18	Female NPT	1	53.8	(2.12)	-	-	23.9	(.94)
FD35-1001-06-06	Female	3/8	3/8	3/8-18	Female NPT	2	65.0	(2.56)	32.3	(1.27)	23.9	(.94)
FD35-1000-06-06	Complete	3/8	3/8	3/8-18	Female NPT	3	89.9	(3.54)	-	-	-	-

Dimensions (Female SAE O-ring, Valved)

Part Number Buna-N	Coupling Type	Body Size	Port Size	Thread	Type	Fig.	Dimensions					
							A		B		Hex Ⓛ	
							mm	(in)	mm	(in)	mm	(in)
FD35-1008-06-06	Male	3/8	9/16	9/16-18	Female SAE O-ring	1	53.8	(2.12)	-	-	23.9	(.94)
FD35-1007-06-06	Female	3/8	9/16	9/16-18	Female SAE O-ring	2	65.0	(2.56)	32.3	(1.27)	23.9	(.94)
FD35-1006-06-06	Complete	3/8	9/16	9/16-18	Female SAE O-ring	3	89.9	(3.54)	-	-	-	-

Dimensions (Female SAE O-ring, 125 PSI Bleed Valve)

Part Number Viton	Coupling Type	Body Size	Port Size	Thread	Type	Fig.	Dimensions			
							A		Hex Ⓛ	
							mm	(in)	mm	(in)
FD-1044-06-06	Male	3/8	9/16	9/16-18	Female SAE O-ring	1	53.8	(2.12)	23.9	(.94)

Note: Incorporates a special relief valve set at 125 psi, preventing disconnected pressure build-up.

Repair Kits

Part Number Viton	Coupling Type
FF10173-06	Male
FF10174-06	Female

Dust Cap/Plug

Part Number (Viton)	Body Size
FD35-1042-06	3/8

Note: Fits male and female halves



Dust Cap/Plug

FD45 Series (Steel)

ISO 7241/1
Series B Interchange



The FD45 Series steel is an industrial interchange popular in North America. Features a rugged ball latch mechanism with automatic self-sealing poppet valves in a wide array of port configurations and multiple valved and non-valved configurations.

Product Features

- Meets dimensional requirements to ISO standard 7241/1 Series B
- PUSH-PULL™ ball latch design allows quick and easy connection and disconnection of hose lines
- Self-sealing poppet valve design provides excellent high and low pressure sealing
- Standard seal material – Buna-N, EPR and Viton
- Standard body material – High resistance carbon steel with zinc trivalent chromate plating (Brass poppet guide in –02 size)

Physical Characteristics

Body Size	Max. Operating Pressure		Min. Burst Pressure		Vacuum (in./Hg)	Rated Flow		Air Inclusion cc. max.	Fluid Loss cc.max.
	bar	(psi)	bar	(psi)		L/min	(gpm)		
1/8	315	(4,500)	945	(13,500)	28	4	(1)	0.50	0.50
1/4	350	(5,000)	1,050	(15,000)	28	11	(3)	0.50	0.50
3/8	280	(4,000)	840	(12,000)	28	23	(6)	2.5	1.3
5/8	280	(4,000)	840	(12,000)	28	45	(12)	4.0	2.8
3/4	280	(4,000)	840	(12,000)	28	106	(28)	11.0	8.2
1	280	(4,000)	840	(12,000)	28	189	(50)	18.0	16.0

Applications

- Hydraulic and fluid transfer



Flow Data

Pressure Drop Versus Flow Graph

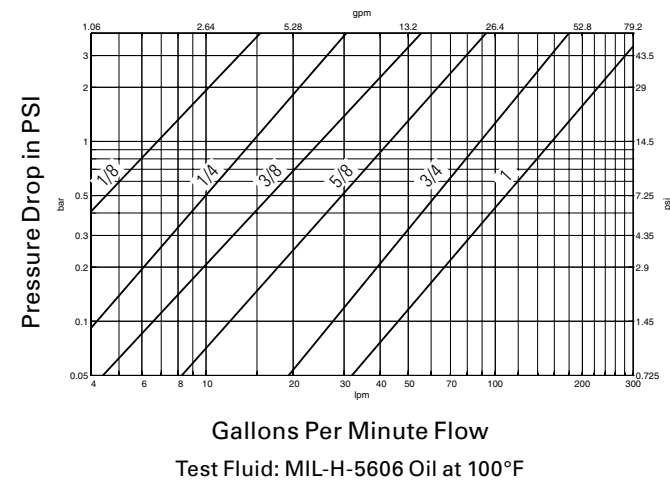

FD45 Series (Steel)

ISO 7241/1
Series B Interchange

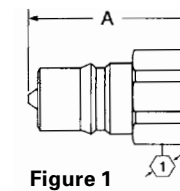

Figure 1

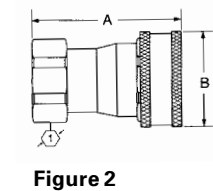

Figure 2

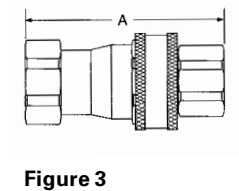

Figure 3

Dimensions (Female NPT, Valved)

Part Number	Buna-N	Viton	EPR	Coupling Type	Body Size	Port Size	Thread Type	Fig.	Dimensions				Hex Ⓛ	
									Fig. A	B	mm	(in)	mm	(in)
FD45-1002-02-02	FD45-1071-02-02	FD45-1064-02-02	Male	1/8	1/8	1/8-27	Female NPT	1	32.5	(1.28)	-	-	14.2	(.56)
FD45-1003-02-02	FD45-1070-02-02	FD45-1065-02-02	Female	1/8	1/8	1/8-27	Female NPT	2	46.0	(1.81)	24.4	(0.96)	19.0	(.75)
FD45-1000-02-02	FD45-1072-02-02	FD45-1063-02-02	Complete	1/8	1/8	1/8-27	Female NPT	3	58.7	(2.31)	-	-	-	-
FD45-1002-04-04	FD45-1071-04-04	FD45-1064-04-04	Male	1/4	1/4	1/4-18	Female NPT	1	38.9	(1.53)	-	-	19.0	(.75)
FD45-1003-04-04	FD45-1070-04-04	FD45-1065-04-04	Female	1/4	1/4	1/4-18	Female NPT	2	56.4	(2.22)	28.7	(1.13)	20.6	(.81)
FD45-1000-04-04	FD45-1072-04-04	FD45-1063-04-04	Complete	1/4	1/4	1/4-18	Female NPT	3	69.3	(2.73)	-	-	-	-
FD45-1002-06-06	FD45-1071-06-06	FD45-1064-06-06	Male	3/8	3/8	3/8-18	Female NPT	1	42.9	(1.69)	-	-	22.4	(.88)
FD45-1003-06-06	FD45-1070-06-06	FD45-1065-06-06	Female	3/8	3/8	3/8-18	Female NPT	2	62.2	(2.45)	35.1	(1.38)	26.9	(1.06)
FD45-1000-06-06	FD45-1072-06-06	FD45-1063-06-06	Complete	3/8	3/8	3/8-18	Female NPT	3	75.7	(2.98)	-	-	-	-
FD45-1002-08-10	FD45-1071-08-10	FD45-1064-08-10	Male	5/8	1/2	1/2-14	Female NPT	1	49.8	(1.96)	-	-	26.9	(1.06)
FD45-1003-08-10	FD45-1070-08-10	FD45-1065-08-10	Female	5/8	1/2	1/2-14	Female NPT	2	72.6	(2.86)	42.9	(1.69)	33.3	(1.31)
FD45-1000-08-10	FD45-1072-08-10	FD45-1063-08-10	Complete	5/8	1/2	1/2-14	Female NPT	3	89.4	(3.52)	-	-	-	-
FD45-1002-12-12	FD45-1071-12-12	FD45-1064-12-12	Male	3/4	3/4	3/4-14	Female NPT	1	61.2	(2.41)	-	-	33.3	(1.31)
FD45-1003-12-12	FD45-1070-12-12	FD45-1065-12-12	Female	3/4	3/4	3/4-14	Female NPT	2	86.4	(3.40)	52.3	(2.06)	41.1	(1.62)
FD45-1000-12-12	FD45-1072-12-12	FD45-1063-12-12	Complete	3/4	3/4	3/4-14	Female NPT	3	101.6	(4.00)	-	-	-	-
FD45-1002-16-16	FD45-1071-16-16	FD45-1064-16-16	Male	1	1	1-11 1/2	Female NPT	1	70.4	(2.77)	-	-	41.1	(1.62)
FD45-1003-16-16	FD45-1070-16-16	FD45-1065-16-16	Female	1	1	1-11 1/2	Female NPT	2	102.1	(4.02)	62.0	(2.44)	50.8	(2.00)
FD45-1000-16-16	FD45-1072-16-16	FD45-1063-16-16	Complete	1	1	1-11 1/2	Female NPT	3	123.4	(4.86)	-	-	-	-

Dimensions (Female NPT, Non-Valved)

Part Number	Buna-N	Viton	EPR	Coupling Type	Body Size	Port Size	Thread Type	Fig.	Dimensions				Hex Ⓛ	
									Fig. A	B	mm	(in)	mm	(in)
FD45-1061-04-04	FD45-1061-04-04	FD45-1061-04-04	Male	1/4	1/4	1/4-18	Female NPT	1	34.8	(1.37)	-	-	19.0	(.75)
FD45-1047-04-04	FD45-1172-04-04	FD45-1207-04-04	Female	1/4	1/4	1/4-18	Female NPT	2	56.4	(2.22)	28.7	(1.13)	20.6	(.81)
FD45-1044-04-04	FD45-1173-04-04	FD45-1206-04-04	Complete	1/4	1/4	1/4-18	Female NPT	3	69.3	(2.73)	-	-	-	-
FD45-1061-06-06	FD45-1061-06-06	FD45-1061-06-06	Male	3/8	3/8	3/8-18	Female NPT	1	38.1	(1.50)	-	-	22.4	(.88)
FD45-1047-06-06	FD45-1172-06-06	FD45-1207-06-06	Female	3/8	3/8	3/8-18	Female NPT	2	62.2	(2.45)	35.1	(1.38)	26.9	(1.06)
FD45-1044-06-06	FD45-1173-06-06	FD45-1206-06-06	Complete	3/8	3/8	3/8-18	Female NPT	3	75.7	(2.98)	-	-	-	-
FD45-1061-08-10	FD45-1061-08-10	FD45-1061-08-10	Male	5/8	1/2	1/2-14	Female NPT	1	44.7	(1.76)	-	-	26.9	(1.06)
FD45-1047-08-10	FD45-1172-08-10	FD45-1207-08-10	Female	5/8	1/2	1/2-14	Female NPT	2	72.6	(2.86)	42.9	(1.69)	33.3	(1.31)
FD45-1044-08-10	FD45-1173-08-10	FD45-1206-08-10	Complete	5/8	1/2	1/2-14	Female NPT	3	89.4	(3.52)	-	-	-	-
FD45-1061-12-12	FD45-1061-12-12	FD45-1061-12-12	Male	3/4	3/4	3/4-14	Female NPT	1	50.8	(2.00)	-	-	33.3	(1.31)
FD45-1047-12-12	FD45-1172-12-12	FD45-1207-12-12	Female	3/4	3/4	3/4-14	Female NPT	2	86.4	(3.40)	52.3	(2.06)	41.1	(1.62)
FD45-1044-12-12	FD45-1173-12-12	FD45-1206-12-12	Complete	3/4	3/4	3/4-14	Female NPT	3	101.6	(4.00)	-	-	-	-
FD45-1061-16-16	FD45-1061-16-16	FD45-1061-16-16	Male	1	1	1-11 1/2	Female NPT	1	61.7	(2.43)	-	-	41.1	(1.62)
FD45-1047-16-16	FD45-1172-16-16	FD45-1207-16-16	Female	1	1	1-11 1/2	Female NPT	2	102.1	(4.02)	62.0	(2.44)	50.8	(2.00)
FD45-1044-16-16	FD45-1173-16-16	FD45-1206-16-16	Complete	1	1	1-11 1/2	Female NPT	3	123.4	(4.86)	-	-	-	-

Note: Will not operate with valved coupling halves; no valve actuator.

FD45 Series (Steel)

ISO 7241/1
Series B Interchange

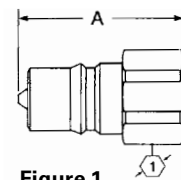

Figure 1

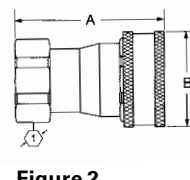

Figure 2

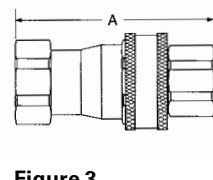

Figure 3

Dimensions (Female NPT, Pusher-Style Valving)

Part Number Buna-N	Viton	EPR	Coupling Type	Body Size	Port Size	Thread	Type	Fig.	Dimensions		Hex			
									A	B	mm	(in)		
FD45-1046-04-04	FD45-1046-04-04	FD45-1046-04-04	Male	1/4	1/4	1/4-18	Female NPT	1	38.1	(1.50)	-	-	19.0	(.75)
FD45-1045-04-04	FD45-1228-04-04	FD45-1229-04-04	Female	1/4	1/4	1/4-18	Female NPT	2	56.4	(2.22)	28.7	(1.13)	20.6	(.81)
FD45-1046-06-06	FD45-1046-06-06	FD45-1046-06-06	Male	3/8	3/8	3/8-18	Female NPT	1	42.2	(1.66)	-	-	22.4	(.88)
FD45-1045-06-06	FD45-1228-06-06	FD45-1229-06-06	Female	3/8	3/8	3/8-18	Female NPT	2	62.2	(2.45)	35.1	(1.38)	26.9	(1.06)
FD45-1046-08-10	FD45-1046-08-10	FD45-1046-08-10	Male	5/8	1/2	1/2-14	Female NPT	1	49.0	(1.93)	-	-	26.9	(1.06)
FD45-1045-08-10	FD45-1228-08-10	FD45-1229-08-10	Female	5/8	1/2	1/2-14	Female NPT	2	72.6	(2.86)	42.9	(1.69)	33.3	(1.31)
FD45-1046-12-12	FD45-1046-12-12	FD45-1046-12-12	Male	3/4	3/4	3/4-14	Female NPT	1	57.4	(2.26)	-	-	33.3	(1.31)
FD45-1045-12-12	FD45-1228-12-12	FD45-1229-12-12	Female	3/4	3/4	3/4-14	Female NPT	2	86.4	(3.40)	52.3	(2.06)	41.1	(1.62)
FD45-1046-16-16	FD45-1046-16-16	FD45-1046-16-16	Male	1	1	1-11 1/2	Female NPT	1	69.1	(2.72)	-	-	41.1	(1.62)
FD45-1045-16-16	FD45-1228-16-16	FD45-1229-16-16	Female	1	1	1-11 1/2	Female NPT	2	102.1	(4.02)	62.0	(2.44)	50.8	(2.00)

Note: Incorporates a pusher device to open mating valved coupling halves.

Dimensions (Female SAE O-ring, Valved)

Part Number Buna-N	EPR	Coupling Type	Body Size	Port Size	Thread	Type	Fig.	Dimensions		Hex			
								A	B	mm	(in)		
FD45-1415-06-04	FD45-1238-06-04	Male	1/4	9/16	9/16-18	Female SAE O-Ring	1	42.7	(1.68)	-	-	20.6	(.81)
FD45-1414-06-04*	FD45-1237-06-04*	Female	1/4	9/16	9/16-18	Female SAE O-Ring	2	58.7	(2.31)	28.7	(1.13)	23.9	(.94)
FD45-1168-08-06													
FD45-1169-08-06													
FD45-1168-16-16	-	Male	1	1 5/16	1 5/16-12	Female SAE O-Ring	1	69.1	(2.72)	-	-	41.1	(1.62)
FD45-1169-16-16	-	Female	1	1 5/16	1 5/16-12	Female SAE O-Ring	2	102.1	(4.02)	61.5	(2.42)	50.8	(2.00)

*With sleeve lock.

Repair Kits

Part Number Buna-N	Viton	EPR	Body Size
FF013-02*	FF014-02*	FF015-02	1/8
FF013-04	FF014-04	FF015-04	1/4
FF013-06	FF014-06	FF015-06	3/8
FF013-10	FF014-10	FF015-10	5/8
FF013-12	FF014-12	FF015-12	3/4
FF013-16	FF014-16	FF015-16	1

Note: Each kit will repair one male or female half.

*The -02 coupling size valving is not repairable. This size repair kit contains an interface seal and back-up ring.

Dust Caps

Part Number (Viton)	Body Size	Part Number (Viton)	Body Size
FD45-1040-02	1/8	FD45-1041-02	1/8
FD45-1040-04	1/4	FD45-1041-04	1/4
FD45-1040-06	3/8	FD45-1041-06	3/8
FD45-1040-10	5/8	FD45-1041-10	5/8
FD45-1040-12	3/4	FD45-1041-12	3/4
FD45-1040-16	1	FD45-1041-16	1

Dust Plugs



Dust Cap

Dust Plug

FD45 Series (Brass)

ISO 7241/1
Series B Interchange



Product Features

- Meets dimensional requirements to ISO standard 7241/1 Series B
- Brass construction with stainless steel springs for greater corrosion resistance and fluid compatibility
- PUSH-PULL™ ball latch design allows quick and easy connection and disconnection of hose lines
- Self-sealing poppet valves provide excellent high and low pressure sealing
- Dual interface O-Rings in the female half provide redundant sealing while connected
- Standard seal material – Buna-N, EPR and Viton
- Standard body material – Brass with stainless steel springs and balls

The FD45 brass is a general purpose industrial interchange coupling available in valved or non-valved designs, offered in brass for excellent corrosion resistance in rugged applications where stainless steel is unacceptable. Features a ball latch mechanism with automatic self-sealing poppet valves.

Physical Characteristics

Body Size	Max. Operating Pressure		Min. Burst Pressure		Rated Vacuum		Flow		Air Inclusion	Fluid Loss	
	bar	(psi)	bar	(psi)	bar	(psi)	L/min	(gpm)	cc. max.	cc.max.	
1/8	70	(1,000)	770	(11,000)	840	(12,000)	28	4	(1)	0.50	0.006
1/4	70	(1,000)	1,260	(18,000)	980	(14,000)	28	11	(3)	0.50	0.012
3/8	70	(1,000)	840	(12,000)	630	(9,000)	28	23	(6)	2.5	0.020
5/8	70	(1,000)	840	(12,000)	455	(6,500)	28	45	(12)	4.0	0.026
3/4	70	(1,000)	700	(10,000)	700	(10,000)	28	106	(28)	11.0	0.032
1	70	(1,000)	595	(8,500)	770	(11,000)	28	189	(50)	18.0	0.010
1 1/4	70	(1,000)	420	(6,000)	420	(6,000)	28	284	(75)	30.0	0.050



Applications

- Hydraulics and fluid transfer
- Water/coolant
- Electronics (cooling)



Flow Data

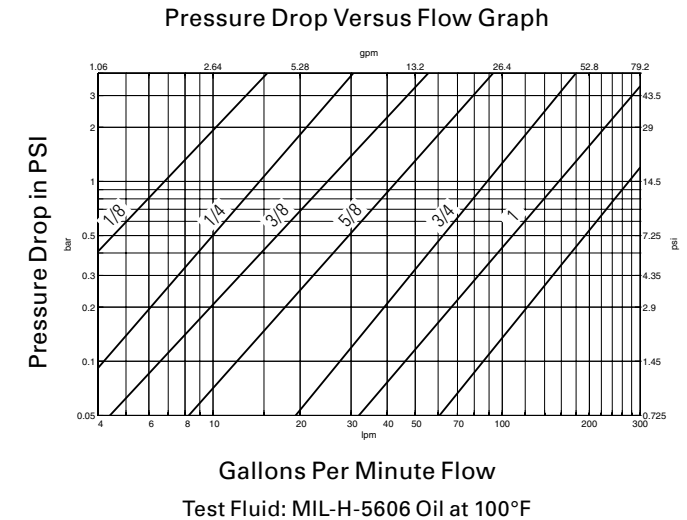

FD45 Series (Brass)

ISO 7241/1
Series B Interchange

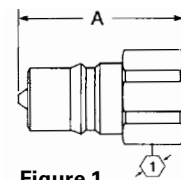

Figure 1

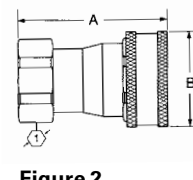

Figure 2

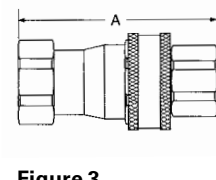

Figure 3

Dimensions (Female NPT, Valved)

Part Number Buna-N	Viton	EPR	Coupling Type	Body Size	Port Size	Thread	Type	Dimensions					
								Fig. A	B	Hex Ⓛ			
								mm	(in)	mm	(in)	mm	(in)
FD45-1086-02-02	FD45-1092-02-02	FD45-1153-02-02	Male	1/8	1/8	1/8-27	Female NPT	1	32.5 (1.28)	-	-	14.2 (.56)	
FD45-1101-02-02	FD45-1091-02-02	FD45-1156-02-02	Female	1/8	1/8	1/8-27	Female NPT	2	46.0 (1.81)	23.9 (.94)	19 (.75)		
FD45-1100-02-02	FD45-1090-02-02	FD45-1157-02-02	Complete	1/8	1/8	1/8-27	Female NPT	3	58.7 (2.31)	-	-	-	-
FD45-1086-04-04	FD45-1092-04-04	FD45-1153-04-04	Male	1/4	1/4	1/4-18	Female NPT	1	38.9 (1.53)	-	-	17.526 (.69)	
FD45-1101-04-04	FD45-1091-04-04	FD45-1156-04-04	Female	1/4	1/4	1/4-18	Female NPT	2	56.4 (2.22)	28.7 (1.13)	20.6 (.81)		
FD45-1100-04-04	FD45-1090-04-04	FD45-1157-04-04	Complete	1/4	1/4	1/4-18	Female NPT	3	69.6 (2.74)	-	-	-	-
FD45-1086-06-06	FD45-1092-06-06	FD45-1153-06-06	Male	3/8	3/8	3/8-18	Female NPT	1	42.9 (1.69)	-	-	22.4 (.88)	
FD45-1101-06-06	FD45-1091-06-06	FD45-1156-06-06	Female	3/8	3/8	3/8-18	Female NPT	2	62.2 (2.45)	35.1 (1.38)	26.9 (1.06)		
FD45-1100-06-06	FD45-1090-06-06	FD45-1157-06-06	Complete	3/8	3/8	3/8-18	Female NPT	3	75.9 (2.99)	-	-	-	-
FD45-1086-08-10	FD45-1092-08-10	FD45-1153-08-10	Male	5/8	1/2	1/2-14	Female NPT	1	49.8 (1.96)	-	-	26.9 (1.06)	
FD45-1101-08-10	FD45-1091-08-10	FD45-1156-08-10	Female	5/8	1/2	1/2-14	Female NPT	2	72.6 (2.86)	42.9 (1.69)	33.3 (1.31)		
FD45-1100-08-10	FD45-1090-08-10	FD45-1157-08-10	Complete	5/8	1/2	1/2-14	Female NPT	3	89.9 (3.54)	-	-	-	-
FD45-1086-12-12	FD45-1092-12-12	FD45-1153-12-12	Male	3/4	3/4	3/4-14	Female NPT	1	61.2 (2.41)	-	-	33.3 (1.31)	
FD45-1101-12-12	FD45-1091-12-12	FD45-1156-12-12	Female	3/4	3/4	3/4-14	Female NPT	2	86.4 (3.40)	51.1 (2.01)	41.1 (1.62)		
FD45-1100-12-12	FD45-1090-12-12	FD45-1157-12-12	Complete	3/4	3/4	3/4-14	Female NPT	3	102.1 (4.02)	-	-	-	-
FD45-1086-16-16	FD45-1092-16-16	FD45-1153-16-16	Male	1	1	1-11 1/2	Female NPT	1	70.4 (2.77)	-	-	41.1 (1.62)	
FD45-1101-16-16	FD45-1091-16-16	FD45-1156-16-16	Female	1	1	1-11 1/2	Female NPT	2	102.1 (4.02)	60.5 (2.38)	50.8 (2.00)		
FD45-1100-16-16	FD45-1090-16-16	FD45-1157-16-16	Complete	1	1	1-11 1/2	Female NPT	3	123.4 (4.86)	-	-	-	-
FD45-1086-20-20	FD45-1092-20-20	FD45-1153-20-20	Male	5/4	1 1/4	1 1/4-11 1/2	Female NPT	1	108.0 (4.25)	-	-	60.5 (2.38)	
FD45-1101-20-20	FD45-1091-20-20	FD45-1156-20-20	Female	5/4	1 1/4	1 1/4-11 1/2	Female NPT	2	114.0 (4.49)	66.5 (2.62)	60.5 (2.38)		
FD45-1100-20-20	FD45-1090-20-20	FD45-1157-20-20	Complete	5/4	1 1/4	1 1/4-11 1/2	Female NPT	3	172.7 (6.80)	-	-	-	-

Dimensions (Female NPT, Non-Valved*)

Part Number Buna-N	Viton	EPR	Coupling Type	Body Size	Port Size	Thread	Type	Dimensions					
								Fig. A	B	Hex Ⓛ			
								mm	(in)	mm	(in)	mm	(in)
FD45-1175-02-02	FD45-1175-02-02	FD45-1175-02-02	Male	1/8	1/8	1/8-27	Female NPT	1	30.5 (1.20)	-	-	14.2 (.56)	
FD45-1176-02-02	FD45-1180-02-02	FD45-1178-02-02	Female	1/8	1/8	1/8-27	Female NPT	2	46.0 (1.81)	24.4 (.96)	19.1 (.75)		
FD45-1174-02-02	FD45-1179-02-02	FD45-1177-02-02	Complete	1/8	1/8	1/8-27	Female NPT	3	58.7 (2.31)	-	-	-	-
FD45-1175-04-04	FD45-1175-04-04	FD45-1175-04-04	Male	1/4	1/4	1/4-18	Female NPT	1	34.8 (1.37)	-	-	17.5 (.69)	
FD45-1176-04-04	FD45-1180-04-04	FD45-1178-04-04	Female	1/4	1/4	1/4-18	Female NPT	2	56.4 (2.22)	28.7 (1.13)	20.6 (.81)		
FD45-1174-04-04	FD45-1179-04-04	FD45-1177-04-04	Complete	1/4	1/4	1/4-18	Female NPT	3	69.6 (2.74)	-	-	-	-
FD45-1175-06-06	FD45-1175-06-06	FD45-1175-06-06	Male	3/8	3/8	3/8-18	Female NPT	1	20.6 (1.50)	-	-	22.4 (.88)	
FD45-1176-06-06	FD45-1180-06-06	FD45-1178-06-06	Female	3/8	3/8	3/8-18	Female NPT	2	62.2 (2.45)	35.1 (1.38)	26.9 (1.06)		
FD45-1174-06-06	FD45-1179-06-06	FD45-1177-06-06	Complete	3/8	3/8	3/8-18	Female NPT	3	77.2 (3.04)	-	-	-	-
FD45-1175-08-10	FD45-1175-08-10	FD45-1175-08-10	Male	5/8	1/2	1/2-14	Female NPT	1	44.7 (1.76)	-	-	26.9 (1.06)	
FD45-1176-08-10	FD45-1180-08-10	FD45-1178-08-10	Female	5/8	1/2	1/2-14	Female NPT	2	72.6 (2.86)	42.9 (1.69)	33.3 (1.31)		
FD45-1174-08-10	FD45-1179-08-10	FD45-1177-08-10	Complete	5/8	1/2	1/2-14	Female NPT	3	89.9 (3.54)	-	-	-	-
FD45-1175-12-12	FD45-1175-12-12	FD45-1175-12-12	Male	3/4	3/4	3/4-14	Female NPT	1	50.8 (2.00)	-	-	33.3 (1.31)	
FD45-1176-12-12	FD45-1180-12-12	FD45-1178-12-12	Female	3/4	3/4	3/4-14	Female NPT	2	86.4 (3.40)	51.1 (2.01)	41.1 (1.62)		
FD45-1174-12-12	FD45-1179-12-12	FD45-1177-12-12	Complete	3/4	3/4	3/4-14	Female NPT	3	102.1 (4.02)	-	-	-	-
FD45-1175-16-16	FD45-1175-16-16	FD45-1175-16-16	Male	1	1	1-11 1/2	Female NPT	1	61.7 (2.43)	-	-	41.1 (1.62)	
FD45-1176-16-16	FD45-1180-16-16	FD45-1178-16-16	Female	1	1	1-11 1/2	Female NPT	2	102.1 (4.02)	60.5 (2.38)	50.8 (2.00)		
FD45-1174-16-16	FD45-1179-16-16	FD45-1177-16-16	Complete	1	1	1-11 1/2	Female NPT	3	124.0 (4.88)	-	-	-	-
FD45-1175-20-20	FD45-1399-20-20	FD45-1400-20-20	Male	5/4	1 1/4	1 1/4-11 1/2	Female NPT	1	108.0 (4.25)	-	-	60.5 (2.38)	
FD45-1176-20-20	FD45-1180-20-20	FD45-1178-20-20	Female	5/4	1 1/4	1 1/4-11 1/2	Female NPT	2	114.0 (4.49)	66.5 (2.62)	60.5 (2.38)		
FD45-1174-20-20	FD45-1179-20-20	FD45-1177-20-20	Complete	5/4	1 1/4	1 1/4-11 1/2	Female NPT	3	172.7 (6.80)	-	-	-	-

*Will not operate with valved coupling halves; no valve actuator.

FD45 Series (Brass)

ISO 7241/1
Series B Interchange

Dimensions (Female NPT, Pusher-Style Valving)

Part Number Buna-N	Viton	EPR	Coupling Type	Body Size	Port Size	Thread	Type	Dimensions					
								Fig. A	B	Hex Ⓛ			
								mm	(in)	mm	(in)	mm	(in)
FD45-1201-04-04	FD45-1201-04-04	FD45-1201-04-04	Male	1/4	1/4	1/4-18	Female NPT	1	38.1 (1.50)	-	-	17.5 (.69)	
FD45-1203-04-04	FD45-1199-04-04	FD45-1211-04-04	Female	1/4	1/4	1/4-18	Female NPT	2	56.4 (2.22)	27.9 (1.10)	20.6 (.81)		
FD45-1201-06-06	FD45-1201-06-06	FD45-1201-06-06	Male	3/8	3/8	3/8-18	Female NPT	1	42.2 (1.66)	-	-	22.4 (.88)	
FD45-1203-06-06	FD45-1199-06-06	FD45-1211-06-06	Female	3/8	3/8	3/8-18	Female NPT	2	62.2 (2.45)	34.5 (1.36)	26.9 (1.06)		
FD45-1201-12-12	FD45-1201-12-12	FD45-1201-12-12	Male	3/4	3/4	3/4-14	Female NPT	1	57.9 (2.28)	-	-	33.3 (1.31)	
FD45-1203-12-12	FD45-1199-12-12	FD45-1211-12-12	Female	3/4	3/4	3/4-14	Female NPT	2	86.4 (3.40)	50.5 (1.99)	41.1 (1.62)		

Note: Incorporates a pusher device to open mating valved coupling halves.

Repair Kits

Part Number Buna-N	Viton	EPR	Body Size
FF016-02†	FF017-02†	FF018-02†	1/8
FF016-04	FF017-04	FF018-04	1/4
FF016-06	FF017-06	FF018-06	3/8
FF016-10	FF017-10	FF018-10	5/8
FF016-12	FF017-12	FF018-12	3/4
FF016-16	FF017-16	FF018-16	1
FF016-20	FF017-20	FF018-20	1 1/4

Note: Each kit will repair one male or female half.

†The -02 coupling size valving is not repairable. This size repair kit contains an interface seal and back-up ring.

Dust Caps

Part Number (Viton)	Body Size
FD45-1040-02	1/8
FD45-1040-04	1/4
FD45-1040-06	3/8
FD45-1040-10	5/8
FD45-1040-12	3/4
FD45-1040-16	1



Dust Cap

Dust Plugs

Part Number (Viton)	Body Size
FD45-1041-02	1/8
FD45-1041-04	1/4
FD45-1041-06	3/8
FD45-1041-10	5/8
FD45-1041-12	3/4
FD45-1041-16	1



Dust Plug

FD45 Series (Stainless Steel)

ISO 7241/1
Series B Interchange



The FD45 stainless steel is a general purpose industrial interchange coupling available in valved or non-valved designs, offered in 303/304 grades of stainless steel for excellent corrosion resistance in rugged applications. Features a ball latch mechanism with automatic self-sealing poppet valves.

Product Features

- Meets dimensional requirements to ISO standard 7241/1 Series B
- 303/304 Stainless steel construction for greater corrosion resistance and fluid compatibility
- PUSH-PULL™ ball latch design allows quick and easy connection and disconnection of hose lines
- Self-sealing poppet valve design provides excellent high and low pressure sealing
- Standard seal material – Buna-N, EPR and Viton
- Standard body material – 303/304 Stainless Steel

Physical Characteristics

Body Size	Max. Operating Pressure Hydraulic		Pressure Static		Min. Burst Pressure		Vacuum (in./Hg)	Rated Flow		Air Inclusion cc. max.	Fluid Loss cc.max.
	bar	(psi)	bar	(psi)	bar	(psi)		L/min	(gpm)		
1/4	207	(3,000)	207	(3,000)	827	(12,000)	28	11	(3)	0.50	0.5
3/8	103	(1,500)	207	(3,000)	827	(12,000)	28	23	(6)	2.5	1.3
5/8	103	(1,500)	207	(3,000)	827	(12,000)	28	45	(12)	4.0	2.8
3/4	103	(1,500)	207	(3,000)	827	(12,000)	28	106	(28)	11.0	8.2
1	86	(1,250)	207	(3,000)	827	(12,000)	28	189	(50)	18.0	16.0

Applications

- Off-shore and marine hydraulics and fluid transfer
- Chemical processing
- Steam
- Electronics cooling



Flow Data

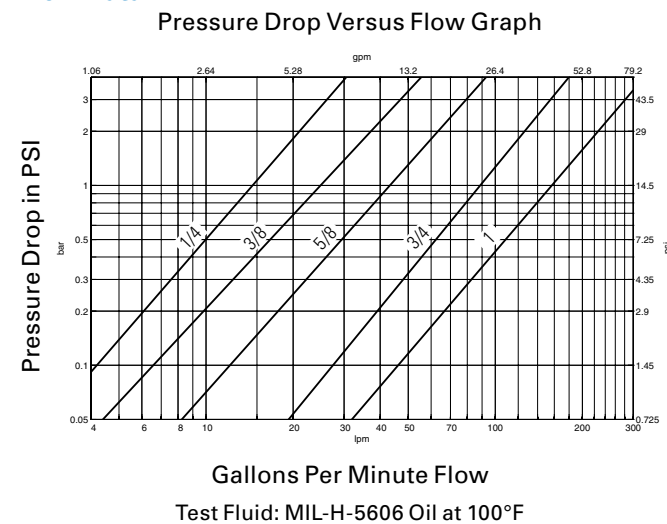

FD45 Series (Stainless Steel)

ISO 7241/1
Series B Interchange

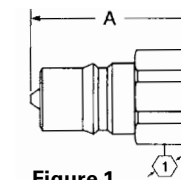

Figure 1

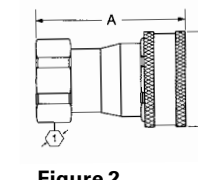

Figure 2

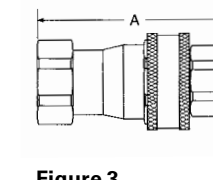

Figure 3

Dimensions (Female NPT, Valved)

Part Number	Buna-N	Viton	EPR	Coupling Type	Body Size	Port Size	Thread	Type	Dimensions					
									Fig. A	B		Hex Ⓛ		
									mm	(in)	mm	(in)	mm	(in)
FD45-1004-04-04	FD45-1078-04-04	FD45-1121-04-04	Male	1/4	1/4	1/4-18	Female NPT	1	37.8	(1.49)	-	-	17.5	(.69)
FD45-1005-04-04	FD45-1076-04-04	FD45-1122-04-04	Female	1/4	1/4	1/4-18	Female NPT	2	56.4	(2.22)	28.7	(1.13)	20.6	(.81)
FD45-1001-04-04	FD45-1075-04-04	FD45-1120-04-04	Complete	1/4	1/4	1/4-18	Female NPT	3	68.6	(2.70)	-	-	-	-
FD45-1004-06-06	FD45-1078-06-06	FD45-1121-06-06	Male	3/8	3/8	3/8-18	Female NPT	1	42.9	(1.69)	-	-	22.4	(.88)
FD45-1005-06-06	FD45-1076-06-06	FD45-1122-06-06	Female	3/8	3/8	3/8-18	Female NPT	2	62.2	(2.45)	35.1	(1.38)	26.9	(1.06)
FD45-1001-06-06	FD45-1075-06-06	FD45-1120-06-06	Complete	3/8	3/8	3/8-18	Female NPT	3	75.7	(2.98)	-	-	-	-
FD45-1004-08-10	FD45-1078-08-10	FD45-1121-08-10	Male	5/8	1/2	1/2-14	Female NPT	1	48.8	(1.92)	-	-	26.9	(1.06)
FD45-1005-08-10	FD45-1076-08-10	FD45-1122-08-10	Female	5/8	1/2	1/2-14	Female NPT	2	72.6	(2.86)	42.9	(1.69)	33.3	(1.31)
FD45-1001-08-10	FD45-1075-08-10	FD45-1120-08-10	Complete	5/8	1/2	1/2-14	Female NPT	3	88.4	(3.48)	-	-	-	-
FD45-1004-12-12	FD45-1078-12-12	FD45-1121-12-12	Male	3/4	3/4	3/4-14	Female NPT	1	58.2	(2.29)	-	-	33.3	(1.31)
FD45-1005-12-12	FD45-1076-12-12	FD45-1122-12-12	Female	3/4	3/4	3/4-14	Female NPT	2	86.4	(3.40)	51.1	(2.01)	41.1	(1.62)
FD45-1001-12-12	FD45-1075-12-12	FD45-1120-12-12	Complete	3/4	3/4	3/4-14	Female NPT	3	101.6	(4.00)	-	-	-	-
FD45-1004-16-16	FD45-1078-16-16	FD45-1121-16-16	Male	1	1	1-11 1/2	Female NPT	1	70.4	(2.77)	-	-	41.1	(1.62)
FD45-1005-16-16	FD45-1076-16-16	FD45-1122-16-16	Female	1	1	1-11 1/2	Female NPT	2	102.1	(4.02)	60.5	(2.38)	50.8	(2.00)
FD45-1001-16-16	FD45-1075-16-16	FD45-1120-16-16	Complete	1	1	1-11 1/2	Female NPT	3	123.4	(4.86)	-	-	-	-

Dimensions (Female NPT, Non-Valved)

Part Number	Buna-N	Viton	EPR	Coupling Type	Body Size	Port Size	Thread	Type	Dimensions					
									Fig. A	B		Hex Ⓛ		
									mm	(in)	mm	(in)	mm	(in)
FD45-1062-04-04	FD45-1062-04-04	FD45-1062-04-04	Male	1/4	1/4	1/4-18	Female NPT	1	33.8	(1.33)	-	-	17.5	(.69)
FD45-1053-04-04	FD45-1195-04-04	FD45-1142-04-04	Female	1/4	1/4	1/4-18	Female NPT	2	56.4	(2.22)	28.7	(1.13)	20.6	(.81)
FD45-1052-04-04	FD45-1194-04-04	FD45-1143-04-04	Complete	1/4	1/4	1/4-18	Female NPT	3	68.6	(2.70)	-	-	-	-
FD45-1062-06-06	FD45-1062-06-06	FD45-1062-06-06	Male	3/8	3/8	3/8-18	Female NPT	1	38.1	(1.50)	-	-	22.4	(.88)
FD45-1053-06-06	FD45-1195-06-06	FD45-1142-06-06	Female	3/8	3/8	3/8-18	Female NPT	2	62.2	(2.45)	35.1	(1.38)	26.9	(1.06)
FD45-1052-06-06	FD45-1194-06-06	FD45-1143-06-06	Complete	3/8	3/8	3/8-18	Female NPT	3	75.7	(2.98)	-	-	-	-
FD45-1062-08-10	FD45-1062-08-10	FD45-1062-08-10	Male	5/8	1/2	1/2-14	Female NPT	1	43.7	(1.72)	-	-	26.9	(1.06)
FD45-1053-08-10	FD45-1195-08-10	FD45-1142-08-10	Female	5/8	1/2	1/2-14	Female NPT	2	72.6	(2.86)	42.9	(1.69)	33.3	(1.31)
FD45-1052-08-10	FD45-1194-08-10	FD45-1143-08-10	Complete	5/8	1/2	1/2-14	Female NPT	3	88.4	(3.48)	-	-	-	-
FD45-1062-12-12	FD45-1062-12-12	FD45-1062-12-12	Male	3/4	3/4	3/4-14	Female NPT	1	50.8	(2.00)	-	-	33.3	(1.31)
FD45-1053-12-12	FD45-1195-12-12	FD45-1142-12-12	Female	3/4	3/4	3/4-14	Female NPT	2	89.4	(3.52)	51.1	(2.01)	41.1	(1.62)
FD45-1052-12-12	FD45-1194-12-12	FD45-1143-12-12	Complete	3/4	3/4	3/4-14	Female NPT	3	101.6	(4.00)	-	-	-	-
FD45-1062-16-16	FD45-1062-16-16	FD45-1062-16-16	Male	1	1	1-11 1/2	Female NPT	1	61.7	(2.43)	-	-	41.1	(1.62)
FD45-1053-16-16	FD45-1195-16-16	FD45-1142-16-16	Female	1	1	1-11 1/2	Female NPT	2	102.1	(4.02)	60.5	(2.38)	50.8	(2.00)
FD45-1052-16-16	FD45-1194-16-16	FD45-1143-16-16	Complete	1	1	1-11 1/2	Female NPT	3	123.4	(4.86)	-	-	-	-

Note: Will not operate with valved coupling halves; no valve actuator.

FD45 Series (Stainless Steel)

ISO 7241/1
Series B Interchange

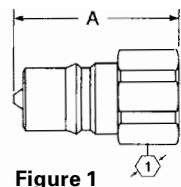

Figure 1

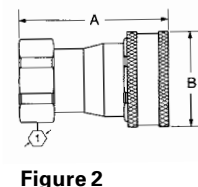

Figure 2

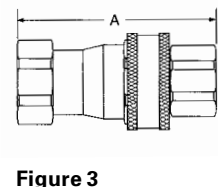

Figure 3

Dimensions (Female NPT, Pusher-Style Valving)

Part Number Buna-N	Viton	EPR	Coupling Type	Body Size	Port Size	Thread	Type	Fig.	Dimensions					
									A	B	Hex ①			
									mm	(in)	mm	(in)	mm	(in)
FD45-1059-04-04	FD45-1059-04-04	FD45-1059-04-04	Male	1/4	1/4	1/4-18	Female NPT	1	33.8	(1.33)	-	-	17.5	(.69)
FD45-1056-04-04	FD45-1197-04-04	FD45-1209-04-04	Female	1/4	1/4	1/4-18	Female NPT	2	56.4	(2.22)	28.7	(1.13)	20.6	(.81)
FD45-1059-06-06	FD45-1059-06-06	FD45-1059-06-06	Male	3/8	3/8	3/8-18	Female NPT	1	38.1	(1.50)	-	-	22.4	(.88)
FD45-1056-06-06	FD45-1197-06-06	FD45-1209-06-06	Female	3/8	3/8	3/8-18	Female NPT	2	62.2	(2.45)	35.1	(1.38)	26.9	(1.06)
FD45-1059-08-10	FD45-1059-08-10	FD45-1059-08-10	Male	5/8	1/2	1/2-14	Female NPT	1	43.7	(1.72)	-	-	26.9	(1.06)
FD45-1056-08-10	FD45-1197-08-10	FD45-1209-08-10	Female	5/8	1/2	1/2-14	Female NPT	2	72.6	(2.86)	42.9	(1.69)	33.3	(1.31)
FD45-1059-12-12	FD45-1059-12-12	FD45-1059-12-12	Male	3/4	3/4	3/4-14	Female NPT	1	50.8	(2.00)	-	-	33.3	(1.31)
FD45-1056-12-12	FD45-1197-12-12	FD45-1209-12-12	Female	3/4	3/4	3/4-14	Female NPT	2	89.4	(3.52)	51.1	(2.01)	41.1	(1.62)
FD45-1059-16-16	FD45-1059-16-16	FD45-1059-16-16	Male	1	1	1-11 1/2	Female NPT	1	61.7	(2.43)	-	-	41.1	(1.62)
FD45-1056-16-16	FD45-1197-16-16	FD45-1209-16-16	Female	1	1	1-11 1/2	Female NPT	2	102.1	(4.02)	60.5	(2.38)	50.8	(2.00)

Note: Incorporates a pusher device to open mating valved coupling halves.

Fryer Coupling/Male Half
Female Pipe/Valved

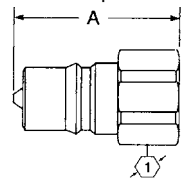

Figure 4

Fryer Coupling/Female Half Female Pipe/Valved
Silicone Collar on Ball Release Sleeve

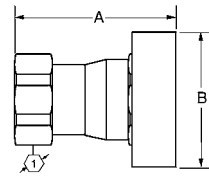

Figure 5

Dimensions (Fryer Coupling*)

Part Number Buna-N	Coupling Type	Body Size	Port Size	Thread	Type	Fig.	Dimensions					
							A	B	Hex ①			
							mm	(in)	mm	(in)	mm	(in)
FD45-1270-08-10	Male	5/8	1/2	1/2-14	Female NPT	4	48.8	(1.92)	-	-	26.9	(1.06)

Dimensions (Female, Valved Silicone Collar on Ball Release Sleeve*)

Part Number Buna-N	Coupling Type	Body Size	Port Size	Thread	Type	Fig.	Dimensions					
							A	B	Hex ①			
							mm	(in)	mm	(in)	mm	(in)
FD45-1267-08-10	Female	5/8	1/2	1/2-14	Female NPT	4	72.6	(2.86)	58.4	(2.38)	33.3	(1.31)

*Special internal Viton seal material approved for use by the National Sanitation Foundation. The fryer coupling uses a silicone collar.

Repair Kits

Part Number Buna-N	Viton	EPR	Body Size
FF054-04	FF055-04	FF056-04	1/4
FF054-06	FF055-06	FF056-06	3/8
FF054-10	FF055-10	FF056-10	5/8
FF054-12	FF055-12	FF056-12	3/4
FF054-16	FF055-16	FF056-16	1

Dust Caps

Part Number Viton	Body Size
FD45-1040-02	1/8
FD45-1040-04	1/4
FD45-1040-06	3/8
FD45-1040-10	5/8
FD45-1040-12	3/4
FD45-1040-16	1

Dust Plugs

Part Number Viton	Body Size
FD45-1041-02	1/8
FD45-1041-04	1/4
FD45-1041-06	3/8
FD45-1041-10	4/8
FD45-1041-12	3/4
FD45-1041-16-16	1



Dust Cap



Dust Plug

FD48 Series

Parker Bruning
SM-250 Interchange



Product Features

- Self-sealing poppet valves provide excellent high and low pressure sealing
- PUSH-PULL™ ball latch design allows quick and easy connection and disconnection of fluid lines
- Heat-treated and plated steel for wear and corrosion resistance
- Standard seal material – Buna-N
- Standard seal material – High resistance carbon steel with zinc trivalent plating

Applications

- Hydraulic and fluid transfer
- Agricultural equipment



Physical Characteristics

Body Size	Max. Operating Pressure		Min. Burst Pressure Connected		Vacuum Conncted Only	Rated Flow		Air Inclusion	Fluid Loss
	bar	(psi)	bar	(psi)	(in./Hg)	L/min	(gpm)	cc. max.	cc.max.
1/4	210	(3,000)	840	(12,000)	28	11	(3)	.50	1.10

Dimensions (Female NPT, Valved)

Part Number Buna-N	Coupling Type	Body Size	Port Size	Thread	Type	Fig.	Dimensions					
							A	B	Hex ①			
							mm	(in)	mm	(in)	mm	(in)
FD48-1002-04-04	Male	1/4	1/4	1/4-18	Female NPT	1	36.8	(1.45)	-	-	19.0	(.75)
FD48-1001-04-04	Female	1/4	1/4	1/4-18	Female NPT	2	51.1	(2.01)	26.9	(1.06)	20.6	(.81)
FD48-1000-04-04	Complete	1/4	1/4	1/4-18	Female NPT	3	68.3	(2.69)	-	-	-	-

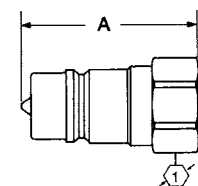

Figure 1

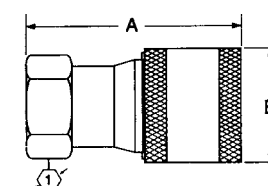

Figure 2

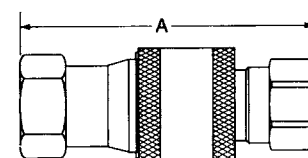

Figure 3

Dust Cap/Plug

Part Number (Buna-N)	Body Size
FD48-1042-04	1/4



Dust Cap/Plug

Flow Data

Pressure Drop Versus Flow Graph

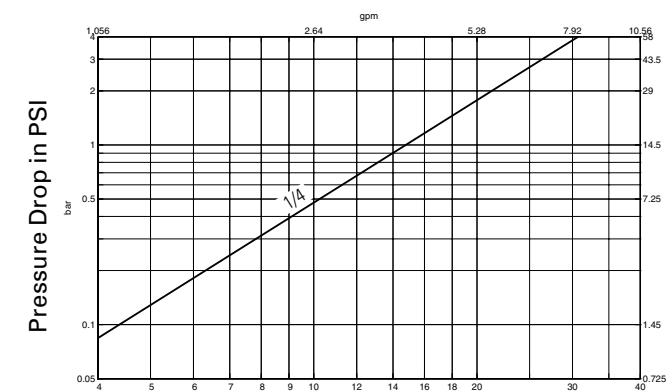

Gallons Per Minute Flow

Test Fluid: MIL-H-5606 Oil at 100°F

FD49 Series

NFPA standard T3.20.15
HTMA Interchange



The FD49 Series meets NFPA standard T3.20.15 and was developed in conjunction with HTMA (Hydraulic Tool Manufacturer's Association). The Eaton Twin-Guard™ sealing system prevents weepage at low pressures and allows connection and disconnection against pressure up to 500 psi.

Product Features

- Dual flush face valving for minimal fluid loss and air inclusion
- Tubular valve and sleeve construction for high fluid flow with low pressure drop
- Push-to-connect latching for one hand operation
- Standard seal material – Teflon channel seal and Buna-N O-Ring backup
- Standard body material – High resistance carbon steel with zinc trivalent plating

Physical Characteristics

Body Size	Max. Operating Pressure		Min. Burst Pressure Connected		Vacuum Connected Only	Rated Flow		Air Inclusion	Fluid Loss
	bar	(psi)	bar	(psi)	(in./Hg)	L/min	(gpm)	cc. max.	cc.max.
3/8	207	(3,000)	621	(9,000)	28	38	(10)	.01	.02



Our Eaton Twin-Guard™ seal system consists of channel and Buna-N O-ring seals. The channel seal prevents blowout during connection and disconnection under pressure to 500 psi. The Buna-N O-ring seal is a secondary seal eliminating fluid weepage.

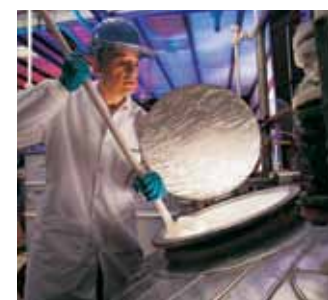

Applications

- Hydraulic tool (HTMA interchange)
- Hydraulic and fluid transfer



Flow Data

Pressure Drop Versus Flow Graph

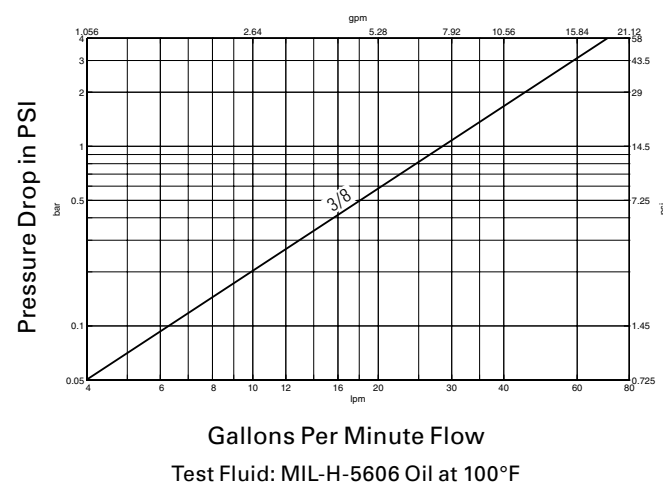

FD49 Series

NFPA Standard T3.20.15
HTMA Interchange

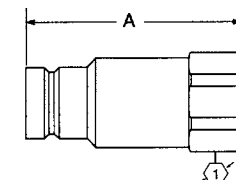

Figure 1

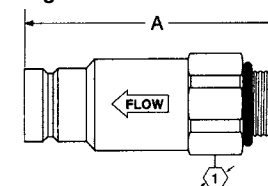

Figure 3

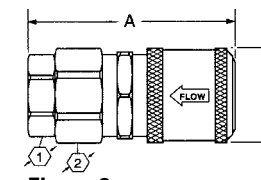

Figure 2

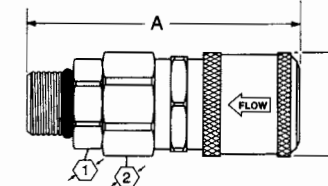

Figure 4

Dimensions (Female NPT, Valved)

Part Number Buna-N	Coupling Type	Body Size	Port Size	Thread Type	Fig. A	Dimensions		Hex ①		Hex ②				
						mm	(in)	mm	(in)	mm	(in)	mm	(in)	
FD49-1002-06-06	Male	3/8	3/8	3/8-18	Female NPT	1	66.5	(2.62)	-	-	25.4	(1.00)	-	-
FD49-1001-06-06	Female	3/8	3/8	3/8-18	Female NPT	2	69.6	(2.74)	30.5	(1.20)	25.4	(1.00)	26.9	(1.06)
FD49-1002-08-06	Male	3/8	1/2	1/2-14	Female NPT	1	69.9	(2.75)	-	-	26.9	(1.06)	-	-
FD49-1001-08-06	Female	3/8	1/2	1/2-14	Female NPT	2	72.4	(2.85)	30.5	(1.20)	-	-	26.9	(1.06)

Dimensions (Female SAE O-ring, Valved)

Part Number Buna-N	Coupling Type	Body Size	Port Size	Thread Type	Fig. A	Dimensions		Hex ①		Hex ②				
						mm	(in)	mm	(in)	mm	(in)	mm	(in)	
FD49-1004-08-06	Male	3/8	3/4	3/4-16	Female SAE O-Ring	1	69.9	(2.75)	-	-	26.9	(1.06)	-	-
FD49-1005-08-06	Female	3/8	3/4	3/4-16	Female SAE O-Ring	2	71.6	(2.82)	30.5	(1.20)	-	-	26.9	(1.06)

Dimensions (Male SAE O-ring, Valved)

Part Number Buna-N	Coupling Type	Body Size	Port Size	Thread Type	Fig. A	Dimensions		Hex ①		Hex ②				
						mm	(in)	mm	(in)	mm	(in)	mm	(in)	
FD49-1057-06-06	Male	3/8	9/16	9/16-18	Male SAE O-Ring	3	75.9	(2.99)	-	-	25.4	(1.00)	-	-
FD49-1014-06-06	Female	3/8	9/16	9/16-18	Male SAE O-Ring	4	81.8	(3.22)	30.5	(1.20)	25.4	(1.00)	26.9	(1.06)
FD49-1057-08-06	Male	3/8	3/4	3/4-16	Male SAE O-Ring	3	75.9	(2.99)	-	-	25.4	(1.00)	-	-
FD49-1014-08-06	Female	3/8	3/4	3/4-16	Male SAE O-Ring	4	83.3	(3.28)	30.5	(1.20)	25.4	(1.00)	26.9	(1.06)

Dust Cap/Plug, Standard Coupling

Part Number (Buna-N)	Body Size
FD49-1042-06	3/8

Note: Fits male and female halves.



Dust Cap/Plug

5100 Series

Thread to Connect



The 5100 Series brass coupling with steel tubular valve offers minimum air inclusion and fluid loss. Thread together latch provides connect under pressure capability and vibration resistance. The 5100 Series is not rated for continuous hydraulic impulse applications. For hydraulic impulse applications, refer to the FD86 and FD96 Series thread to connect product lines.

Product Features

- Tubular valve construction for virtually no fluid loss during disconnection, reduces environmental and worker safety hazards
- Low air inclusion during connection maintains system performance
- Available with wing or hex nut configurations
- Connect against pressure capability allows connecting of halves even when pressurized up to 500 psi
- Steel flange available for accessible bulkhead mounting
- Standard seal material – Buna-N
- Standard body material – Brass body with high resistance carbon steel with zinc trivalent plated valving components, hex and wing nuts

Physical Characteristics

Body Dash Size	Body Interface Size	Max. Operating Pressure Connected		Max. Operating Pressure Disconnected		Vacuum	Rated Flow		Air Inclusion cc. max.	Fluid Loss cc.max.
		bar	(psi)	Male Half S2 and S4	Female Half S5		(in./Hg)	L/min		
1/4	1/4	207	(3,000)	207	(3,000)	28	15	(4)	.03	.01
3/8	1/2	207	(3,000)	207	(3,000)	28	26	(7)	.05	.06
1/2	1/2	207	(3,000)	207	(3,000)	28	26	(7)	.05	.10
5/8	3/4	207	(3,000)	207	(3,000)	28	68	(18)	.14	.10
3/4	3/4	207	(3,000)	207	(3,000)	28	68	(18)	.34	.26
1	1	207	(3,000)	207	(3,000)	28	151	(40)	.50	.35
1 1/4	1 1/4	190	(2,750)	172	(2,500)	28	284	(75)	.68	.70
1 1/2	1 1/2	172	(2,500)	172	(2,500)	28	379	(100)	.60	.94

Applications

- Hydraulics and fluid transfer
- On-highway hydraulic wet lines
- Dump and refuse vehicles
- Bulk liquid transfer



Flow Data

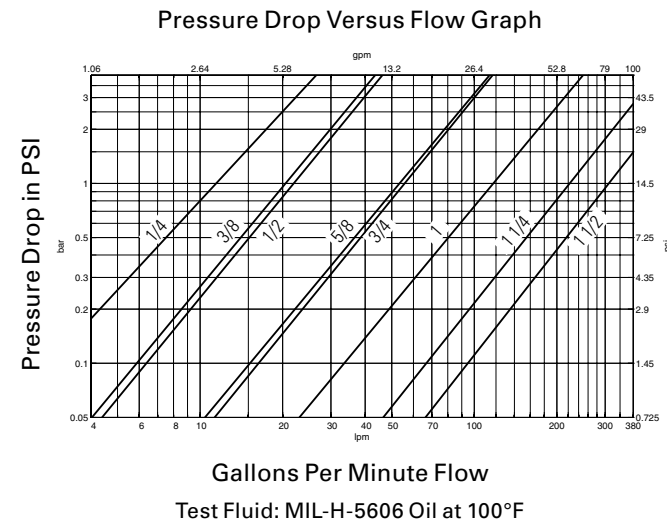

5100 Series

Thread to Connect

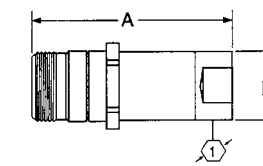

Figure 1

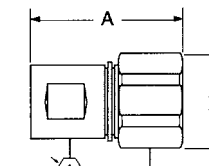

Figure 2

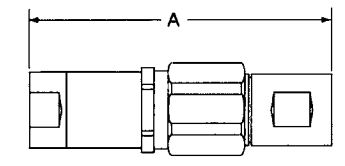

Figure 3

Dimensions (Female NPT, Valved without Flange)

Part Number	Coupling Type	Body Size	Port Size	Thread	Type	Dimensions Fig. A		B		Hex ①		Hex ②	
						mm	(in)	mm	(in)	mm	(in)	mm	(in)
5100-S2-4B	Male	1/4	1/8	1/8-27	Female NPT 1	47.8	(1.88)	22.9	(.90)	17.5	(.69)	-	-
5110-S5-4B	Female	1/4	1/8	1/8-27	Female NPT 2	53.3	(2.10)	17.5	(.69)	14.2	(.56)	30.2	(1.19)
5111-4B	Complete	1/4	1/8	1/8-27	Female NPT 3	81.3	(3.20)	-	-	-	-	-	-
5100-S2-6B	Male	3/8	1/4	1/4-18	Female NPT 1	65.5	(2.58)	26.7	(1.05)	23.9	(.94)	23.9	(.94)
5110-S5-6B	Female	3/8	1/4	1/4-18	Female NPT 2	61.0	(2.40)	22.4	(.88)	19.3	(.76)	35.1	(1.38)
5111-6B	Complete	3/8	1/4	1/4-18	Female NPT 3	104.4	(4.11)	-	-	-	-	-	-
5100-S2-8B	Male	1/2	3/8	3/8-18	Female NPT 1	65.5	(2.58)	26.7	(1.05)	23.9	(.94)	23.9	(.94)
5110-S5-8B	Female	1/2	3/8	3/8-18	Female NPT 2	61.0	(2.40)	22.4	(.88)	19.3	(.76)	35.1	(1.38)
5111-8B	Complete	1/2	3/8	3/8-18	Female NPT 3	104.4	(4.11)	-	-	-	-	-	-
5100-S2-10B	Male	5/8	1/2	1/2-14	Female NPT 1	79.0	(3.11)	35.1	(1.38)	30.2	(1.19)	-	-
5110-S5-10B	Female	5/8	1/2	1/2-14	Female NPT 2	78.0	(3.07)	31.8	(1.25)	29.5	(1.16)	44.5	(1.75)
5111-10B	Complete	5/8	1/2	1/2-14	Female NPT 3	132.3	(5.21)	-	-	-	-	-	-
5100-S2-12B	Male	3/4	3/4	3/4-14	Female NPT 1	79.0	(3.11)	35.1	(1.38)	30.2	(1.19)	-	-
5110-S5-12B	Female	3/4	3/4	3/4-14	Female NPT 2	78.0	(3.07)	31.8	(1.25)	29.5	(1.16)	44.5	(1.75)
5111-12B	Complete	3/4	3/4	3/4-14	Female NPT 3	132.3	(5.21)	-	-	-	-	-	-
5100-S2-16B	Male	1	1	1-11 1/2	Female NPT 1	90.2	(3.55)	44.2	(1.74)	39.6	(1.56)	-	-
5110-S5-16B	Female	1	1	1-11 1/2	Female NPT 2	93.5	(3.68)	39.6	(1.56)	36.6	(1.44)	53.8	(2.12)
5111-16B	Complete	1	1	1-11 1/2	Female NPT 3	151.9	(5.98)	-	-	-	-	-	-
5100-S2-20B	Male	1 1/4	1 1/4	1 1/4 - 11 1/2	Female NPT 1	94.2	(3.71)	52.8	(2.08)	47.8	(1.88)	47.8	(1.88)
5110-S5-20B	Female	1 1/4	1 1/4	1 1/4 - 11 1/2	Female NPT 2	101.6	(4.00)	48.0	(1.89)	45.2	(1.78)	63.5	(2.50)
5111-20B	Complete	1 1/4	1 1/4	1 1/4 - 11 1/2	Female NPT 3	160.3	(6.31)	-	-	-	-	-	-
5100-S2-24B	Male	1 1/2	1 1/2	1 1/2 - 11 1/2	Female NPT 1	104.6	(4.12)	62.5	(2.46)	55.6	(2.19)	55.6	(2.19)
5110-S5-24B	Female	1 1/2	1 1/2	1 1/2 - 11 1/2	Female NPT 2	104.1	(4.10)	55.4	(2.18)	50.8	(2.00)	69.9	(2.75)
5111-24B	Complete	1 1/2	1 1/2	1 1/2 - 11 1/2	Female NPT 3	165.6	(6.52)	-	-	-	-	-	-

5100 Series

Thread to Connect

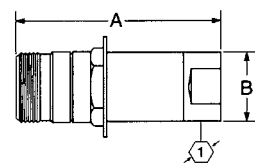

Figure 4

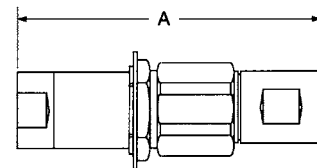

Figure 5

Dimensions (Female NPT, Valved WITH Flange)

Part Number Buna-N	Coupling Type	Body Size	Port Size	Thread	Type	Fig.	Dimensions A		B		Hex Ⓛ	
							mm	(in)	mm	(in)	mm	(in)
5100-S4-4B	Male	1/4	1/8	1/8-27	Female NPT	4	47.8	(1.88)	22.9	(.90)	1.75	(.69)
5110-4B	Complete	1/4	1/8	1/8-27	Female NPT	5	81.3	(3.20)	-	-	-	-
5100-S4-6B	Male	3/8	1/4	1/4-18	Female NPT	4	65.5	(2.58)	26.7	(1.05)	23.9	(.94)
5110-6B	Complete	3/8	1/4	1/4-18	Female NPT	5	104.4	(4.11)	-	-	-	-
5100-S4-8B	Male	1/2	3/8	3/8-18	Female NPT	4	65.5	(2.58)	26.7	(1.05)	23.9	(.94)
5110-8B	Complete	1/2	3/8	3/8-18	Female NPT	5	104.4	(4.11)	-	-	-	-
5100-S4-10B	Male	5/8	1/2	1/2-14	Female NPT	4	79.0	(3.11)	35.2	(1.35)	30.2	(1.19)
5110-10B	Complete	5/8	1/2	1/2-14	Female NPT	5	132.3	(5.21)	-	-	-	-
5100-S4-12B	Male	3/4	3/4	3/4-14	Female NPT	4	79.0	(3.11)	35.2	(1.35)	30.2	(1.19)
5110-12B	Complete	3/4	3/4	3/4-14	Female NPT	5	132.3	(5.21)	-	-	-	-
5100-S4-16B	Male	1	1	1-11 1/2	Female NPT	4	90.2	(3.55)	44.2	(1.74)	39.6	(1.56)
5110-16B	Complete	1	1	1-11 1/2	Female NPT	5	151.9	(5.98)	-	-	-	-
5100-S4-20B	Male	1 1/4	1 1/4	1 1/4 - 11 1/2	Female NPT	4	94.2	(3.71)	52.8	(2.08)	47.8	(1.88)
5110-20B	Complete	1 1/4	1 1/4	1 1/4 - 11 1/2	Female NPT	5	160.3	(6.31)	-	-	-	-
5100-S4-24B	Male	1 1/2	1 1/2	1 1/2 - 11 1/2	Female NPT	4	104.6	(4.12)	62.5	(2.46)	55.6	(2.19)
5110-24B	Complete	1 1/2	1 1/2	1 1/2 - 11 1/2	Female NPT	5	165.6	(6.52)	-	-	-	-

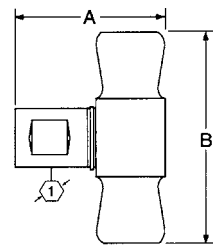

Figure 6

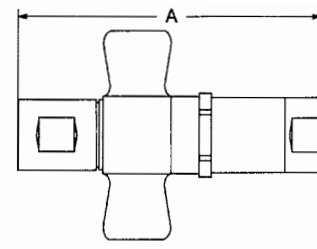

Figure 7

Dimensions (Female NPT, Valved WITH Wing Nut Less Flange)

Part Number Buna-N	Coupling Type	Body Size	Port Size	Thread	Type	Fig.	Dimensions A		B		Hex Ⓛ	
							mm	(in)	mm	(in)	mm	(in)
5100-S5-4B	Female	1/4	1/8	1/8-27	Female NPT	6	53.3	(2.10)	77.0	(3.03)	14.2	(.56)
5101-4B	Complete	1/4	1/8	1/8-27	Female NPT	7	81.3	(3.20)	-	-	-	-
5100-S5-6B	Female	3/8	1/4	1/4-18	Female NPT	6	61.0	(2.40)	87.4	(3.44)	19.3	(.76)
5101-6B	Complete	3/8	1/4	1/4-18	Female NPT	7	104.4	(4.11)	-	-	-	-
5100-S5-8B	Female	1/2	3/8	3/8-18	Female NPT	6	61.0	(2.40)	87.4	(3.44)	19.3	(.76)
5101-8B	Complete	1/2	3/8	3/8-18	Female NPT	7	104.4	(4.11)	-	-	-	-
5100-S5-10B	Female	5/8	1/2	1/2-14	Female NPT	6	78.0	(3.07)	104.9	(4.13)	29.5	(1.16)
5101-10B	Complete	5/8	1/2	1/2-14	Female NPT	7	132.3	(5.21)	-	-	-	-
5100-S5-12B	Female	3/4	3/4	3/4-14	Female NPT	6	78.0	(3.07)	104.9	(4.13)	29.5	(1.16)
5101-12B	Complete	3/4	3/4	3/4-14	Female NPT	7	132.3	(5.21)	-	-	-	-
5100-S5-16B	Female	1	1	1-11 1/2	Female NPT	6	93.5	(3.68)	111.3	(4.38)	36.6	(1.44)
5101-16B	Complete	1	1	1-11 1/2	Female NPT	7	151.9	(5.98)	-	-	-	-
5100-S5-20B	Female	1 1/4	1 1/4	1 1/4 - 11 1/2	Female Pipe	6	101.6	(4.00)	133.9	(5.27)	45.2	(1.78)
5101-20B	Complete	1 1/4	1 1/4	1 1/4 - 11 1/2	Female NPT	7	160.3	(6.31)	-	-	-	-
5100-S5-24B	Female	1 1/2	1 1/2	1 1/2 - 11 1/2	Female NPT	6	104.1	(4.10)	136.7	(5.38)	50.8	(2.00)
5101-24B	Complete	1 1/2	1 1/2	1 1/2 - 11 1/2	Female NPT	7	165.6	(6.52)	-	-	-	-

Note: Uses the 5100-52 series male half shown on page 27.

5100 Series

Thread to Connect

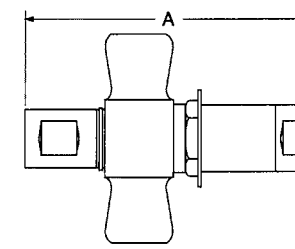

Figure 8

Dimensions (Female NPT, Valved WITH Wing Nut and Flange)

Part Number Buna-N	Coupling Type	Body Size	Port Size	Thread	Type	Fig.	Dimensions A	
							mm	(in)
5100-4B	Complete	1/4	1/8	1/8-27	Female NPT	8	81.3	(3.20)
5100-6B	Complete	3/8	1/4	1/4-18	Female NPT	8	104.4	(4.11)
5100-8B	Complete	1/2	3/8	3/8-18	Female NPT	8	104.4	(4.11)
5100-10B	Complete	5/8	1/2	1/2-14	Female NPT	8	132.3	(5.21)
5100-12B	Complete	3/4	3/4	3/4-14	Female NPT	8	132.3	(5.21)
5100-16B	Complete	1	1	1-11 1/2	Female NPT	8	151.9	(5.98)
5100-20B	Complete	1 1/4	1 1/4	1 1/4 - 11 1/2	Female NPT	8	160.3	(6.31)
5100-24B	Complete	1 1/2	1 1/2	1 1/2 - 11 1/2	Female NPT	8	165.6	(6.52)

Note: Uses the 5100-52 series male half shown on page 27.

Repair Kits

Part Number Buna-N	Body Size
FF098-04	1/4
FF098-08	3/8 & 1/2
FF098-12	5/8 & 3/4
FF082-16	1
FF082-20	1 1/4
FF082-24	1 1/2

Note: Each kit will repair male and female half.

Dust Caps and Dust Plugs

Part Number Dust Cap with Chain	Dust Plug with Chain	Body Size
5100-S7-5	5100-S9-5	1/4
5100-S7-8	5100-S9-8	3/8 & 1/2
5100-S7-12	5100-S9-12	5/8 & 3/4
5100-S7-16	5100-S9-16	1
5100-S7-20	5100-S9-20	1 1/4
5100-S7-24	5100-S9-24	1 1/2

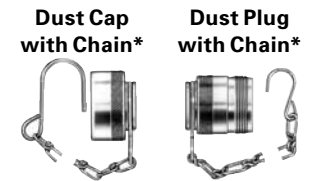

6-Bolt Flange Assembly

Part Number 6-Bolt Flange Assembly	Body Size	Dimensions A		B	
		mm	(in)	mm	(in)
150-22-5	1/4	5.11	(.201)	33.6	(1.44)
150-22-8	3/8 & 1/2	5.11	(.201)	42.9	(1.69)
150-22-12	5/8 & 3/4	5.11	(.201)	53.8	(2.12)
150-22-16	1	5.11	(.201)	60.5	(2.38)
150-22-20	1 1/4	5.11	(.201)	66.5	(2.62)
5100-22-245	1 1/2	5.11	(.201)	82.6	(3.25)

*To order caps and plugs without chain, order cap by part number 5100-32(-size) and plug by part number 5100-41(-size).

**6 Bolt Flange-holes equally spaced. (See "A" for bolt hole diameter, and "B" for bolt circle diameter).

6 Bolt Flange** Assembly

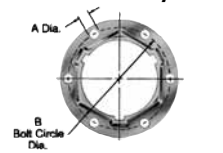

5600 Series

ISO 7241/1
Series A Interchange



The 5600 Series general purpose industrial interchange coupling features a PUSH-PULL™ latch and poppet valving in a low profile design. The 5600 Series features a rugged ball latch mechanism with self-sealing poppet valves in a wide array of port configurations and multiple valved and non-valved configurations.

Product Features

- Meets dimensional requirements to ISO standard 7241/1 Series A
- PUSH-PULL™ ball latch design allows quick and easy connection and disconnection of fluid lines.
- Self-sealing poppet valve provides excellent high and low pressure sealing
- Streamlined valving provides minimum pressure drop
- Standard seal materials – Buna-N, EPR and Viton
- Standard body material – High resistance carbon steel with zinc trivalent plating (Brass poppet guide in -04 size)

Physical Characteristics

Body Size	Max. Operating Pressure		Min. Burst Pressure Connected		Vacuum Conncted Only	Rated Flow		Air Inclusion	Fluid Loss
	bar	(psi)	bar	(psi)	(in./Hg)	L/min	(gpm)	cc. max.	cc.max.
1/4	350	(5,000)	1,050	(15,000)	28	4	(1)	0.50	0.50
3/8	280	(4,000)	840	(12,000)	28	23	(6)	1.5	1.3
5/8	280	(4,000)	840	(12,000)	28	45	(12)	2.8	2.8
3/4	280	(4,000)	840	(12,000)	28	106	(28)	10.0	8.2
1	280	(4,000)	840	(12,000)	28	189	(50)	14.2	14.2

Applications

- Hydraulic fluid transfer
- Agricultural equipment
- Construction equipment
- Dump, snow plow and maintenance vehicles
- In-plant manufacturing



Flow Data

Pressure Drop Versus Flow Graph

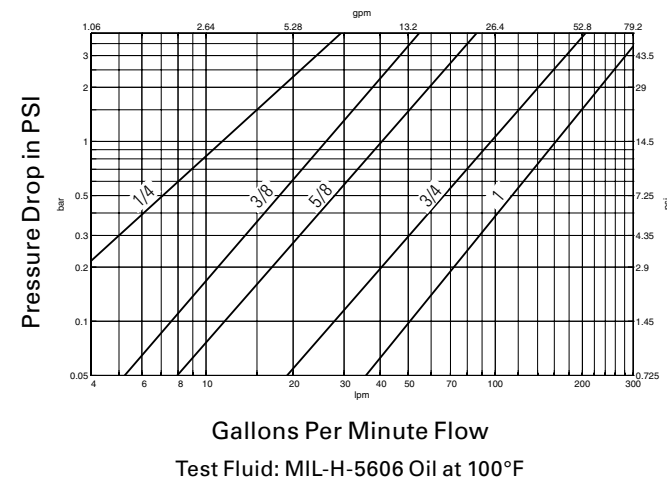

5600 Series

ISO 7241/1
Series A Interchange

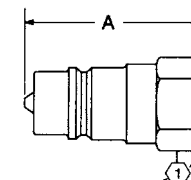

Figure 1

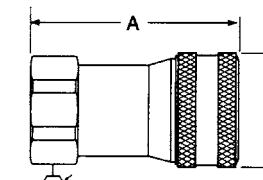

Figure 2

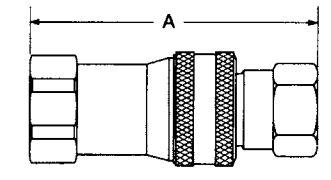

Figure 3

Dimensions (Female NPT, Valved)

Part Number	Buna-N	Viton	EPR	Coupling Type	Body Size	Port Size	Thread	Type	Fig.	Dimensions					
										A	B	Hex Ⓛ			
										mm	(in)	mm	(in)	mm	(in)
5602-2-4S	FD56-1062-02-04	5644-2-4S	Male	1/4	1/8	1/8-27	Female NPT	1	31.5	(1.24)	-	-	14.2	(.56)	
5601-2-4S	FD56-1064-02-04	5643-2-4S	Female	1/4	1/8	1/8-27	Female NPT	2	46	(1.81)	27.4	(1.08)	22.4	(.88)	
5600-2-4S	FD56-1065-02-04	5642-2-4S	Complete	1/4	1/8	1/8-27	Female NPT	3	61.5	(2.42)	-	-	-	-	
5602-4-4S	FD56-1062-04-04	5644-4-4S	Male	1/4	1/4	1/4-18	Female NPT	1	33.3	(1.31)	-	-	19.1	(.75)	
5601-4-4S	FD56-1064-04-04	5643-4-4S	Female	1/4	1/4	1/4-18	Female NPT	2	46	(1.81)	27.4	(1.08)	22.4	(.88)	
5600-4-4S	FD56-1065-04-04	5642-4-4S	Complete	1/4	1/4	1/4-18	Female NPT	3	63.2	(2.49)	-	-	-	-	
5602-6-6S	FD56-1062-06-06	5644-6-6S	Male	3/8	3/8	3/8-18	Female NPT	1	37.3	(1.47)	-	-	22.4	(.88)	
5601-6-6S	FD56-1064-06-06	5643-6-6S	Female	3/8	3/8	3/8-18	Female NPT	2	54.6	(2.15)	31.2	(1.23)	25.4	(1.00)	
5600-6-6S	FD56-1065-06-06	5642-6-6S	Complete	3/8	3/8	3/8-18	Female NPT	3	71.1	(2.80)	-	-	-	-	
5602-8-10S	FD56-1062-08-10	5644-8-10S	Male	5/8	1/2	1/2-14	Female NPT	1	51.3	(2.02)	-	-	26.9	(1.06)	
5601-8-10S	FD56-1064-08-10	5643-8-10S	Female	5/8	1/2	1/2-14	Female NPT	2	66.3	(2.61)	38.1	(1.50)	30.2	(1.19)	
5600-8-10S	FD56-1065-08-10	5642-8-10S	Complete	5/8	1/2	1/2-14	Female NPT	3	96	(3.78)	-	-	-	-	
5602-12-10S	FD56-1062-12-10	5644-12-10S	Male	5/8	3/4	3/4-14	Female NPT	1	54.9	(2.16)	-	-	35.1	(1.38)	
5601-12-10S	FD56-1064-12-10	5643-12-10S	Female	5/8	3/4	3/4-14	Female NPT	2	66.3	(2.61)	38.1	(1.50)	33.3	(1.31)	
5600-12-10S	FD56-1065-12-10	5642-12-10S	Complete	5/8	3/4	3/4-14	Female NPT	3	103.1	(4.06)	-	-	-	-	
5602-12-12S	FD56-1062-12-12	5644-12-12S	Male	3/4	3/4	3/4-14	Female NPT	1	64.8	(2.55)	-	-	35.1	(1.38)	
5601-12-12S	FD56-1064-12-12	5643-12-12S	Female	3/4	3/4	3/4-14	Female NPT	2	82.6	(3.25)	46	(1.81)	38.1	(1.50)	
5600-12-12S	FD56-1065-12-12	5642-12-12S	Complete	3/4	3/4	3/4-14	Female NPT	3	115.8	(4.56)	-	-	-	-	
5602-16-16S	FD56-1062-16-16	5644-16-16S	Male	1	1	1-11 1/2	Female NPT	1	78.7	(3.10)	-	-	41.1	(1.62)	
5601-16-16S	FD56-1064-16-16	5643-16-16S	Female	1	1	1-11 1/2	Female NPT	2	97	(3.82)	53.3	(2.10)	42.9	(1.69)	
5600-16-16S	FD56-1065-16-16	5642-16-16S	Complete	1	1	1-11 1/2	Female NPT	3	123.4	(4.86)	-	-	-	-	

Dimensions (Female NPT, Valved with Sleeve Lock)

Part Number	Buna-N	Coupling Type	Body Size	Port Size	Thread	Type	Fig.	Dimensions					
								A	B	Hex Ⓛ			
								mm	(in)	mm	(in)	mm	(in)
FD56-1239-08-10		Female	5/8	1/2	1/2-14	Female NPT	2	66.3	(2.61)	38.1	(1.50)	30.2	(1.19)
FD56-1239-12-12		Female	3/4	3/4	3/4-14	Female NPT	2	82.6	(3.25)	46.7	(1.84)	38.1	(1.50)
FD56-1239-16-16		Female	1	1	1-11 1/2	Female NPT	2	97.0	(3.82)	54.1	(2.13)	42.9	(1.69)

5600 Series

ISO 7241/1
Series A Interchange

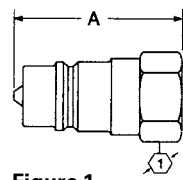

Figure 1

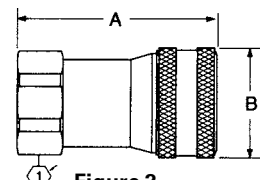

Figure 2

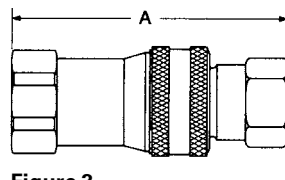

Figure 3

Dimensions (Female NPT, Non-Valved)

Part Number Buna-N	Viton	EPR	Coupling Type	Body Size	Port Size	Thread	Type	Fig.	Dimensions					
									A	B	Hex ①			
									mm	(in)	mm	(in)	mm	(in)
FD56-1037-04-04	FD56-1037-04-04	FD56-1037-04-04	Male	1/4	1/4	1/4-18	Female NPT	1	31.5	(1.24)	-	-	19.1	(.75)
FD56-1225-04-04	FD56-1207-04-04	FD56-1204-04-04	Female	1/4	1/4	1/4-18	Female NPT	2	46.0	(1.81)	27.4	(1.08)	22.4	(.88)
FD56-1226-04-04	FD56-1208-04-04	FD56-1205-04-04	Complete	1/4	1/4	1/4-18	Female NPT	3	63.2	(2.49)	-	-	-	-
FD56-1037-06-06	FD56-1037-06-06	FD56-1037-06-06	Male	3/8	3/8	3/8-18	Female NPT	1	35.6	(1.40)	-	-	22.4	(.88)
FD56-1225-06-06	FD56-1207-06-06	FD56-1204-06-06	Female	3/8	3/8	3/8-18	Female NPT	2	54.6	(2.15)	31.2	(1.23)	25.4	(1.00)
FD56-1226-06-06	FD56-1208-06-06	FD56-1205-06-06	Complete	3/8	3/8	3/8-18	Female NPT	3	71.1	(2.80)	-	-	-	-
FD56-1037-08-10	FD56-1037-08-10	FD56-1037-08-10	Male	5/8	1/2	1/2-14	Female NPT	1	48	(1.89)	-	-	26.9	(1.06)
FD56-1225-08-10	FD56-1207-08-10	FD56-1204-08-10	Female	5/8	1/2	1/2-14	Female NPT	2	66.3	(2.61)	38.1	(1.50)	30.2	(1.19)
FD56-1226-08-10	FD56-1208-08-10	FD56-1205-08-10	Complete	5/8	1/2	1/2-14	Female NPT	3	96	(3.78)	-	-	-	-
FD56-1225-12-12	FD56-1207-12-12	FD56-1204-12-12	Female	3/4	3/4	3/4-14	Female NPT	2	82.6	(3.25)	46.0	(1.81)	38.1	(1.50)
FD56-1226-12-12	FD56-1208-12-12	FD56-1205-12-12	Complete	3/4	3/4	3/4-14	Female NPT	3	113.3	(4.46)	-	-	-	-
FD56-1037-16-16	FD56-1037-16-16	FD56-1037-16-16	Male	1	1	1-11 1/2	Female NPT	1	70.4	(2.77)	-	-	41.1	(1.62)
FD56-1225-16-16	FD56-1207-16-16	FD56-1204-16-16	Female	1	1	1-11 1/2	Female NPT	2	97	(3.82)	53.3	(2.10)	42.9	(1.69)
FD56-1226-16-16	FD56-1208-16-16	FD56-1205-16-16	Complete	1	1	1-11 1/2	Female NPT	3	140.7	(5.54)	-	-	-	-

Note: Will not operate with valved coupling halves; no valve actuator. *Male halves contain no seals.

Dimensions (Female NPT, Pusher-Style Valving)

Part Number Buna-N	Viton	EPR	Coupling Type	Body Size	Port Size	Thread	Type	Fig.	Dimensions					
									A	B	Hex ①			
									mm	(in)	mm	(in)	mm	(in)
FD56-1125-04-04	FD56-1125-04-04	FD56-1125-04-04	Male	1/4	1/4	1/4-18	Female NPT	1	31.5	(1.24)	-	-	19	(.75)
FD56-1123-04-04	FD56-1201-04-04	FD56-1196-04-04	Female	1/4	1/4	1/4-18	Female NPT	2	46	(1.81)	27.4	(1.08)	22.4	(.88)
FD56-1125-06-06	FD56-1125-06-06	FD56-1125-06-06	Male	3/8	3/8	3/8-18	Female NPT	1	35.6	(1.40)	-	-	22.4	(.88)
FD56-1123-06-06	FD56-1201-06-06	FD56-1196-06-06	Female	3/8	3/8	3/8-18	Female NPT	2	54.6	(2.15)	31.2	(1.23)	25.4	(1.00)
FD56-1125-08-10	FD56-1125-08-10	FD56-1125-08-10	Male	5/8	1/2	1/2-14	Female NPT	1	48	(1.89)	-	-	26.9	(1.06)
FD56-1123-08-10	FD56-1201-08-10	FD56-1196-08-10	Female	5/8	1/2	1/2-14	Female NPT	2	66.3	(2.61)	38.1	(1.50)	30.2	(1.19)
FD56-1125-12-12	FD56-1125-12-12	FD56-1125-12-12	Male	3/4	3/4	3/4-14	Female NPT	1	57.9	(2.28)	-	-	35.1	(1.38)
FD56-1123-12-12	FD56-1201-12-12	FD56-1196-12-12	Female	3/4	3/4	3/4-14	Female NPT	2	82.6	(3.25)	46	(1.81)	38.1	(1.50)
FD56-1125-16-16	FD56-1125-16-16	FD56-1125-16-16	Male	1	1	1-11 1/2	Female NPT	1	70.4	(2.77)	-	-	41.1	(1.62)
FD56-1123-16-16	FD56-1201-16-16	FD56-1196-16-16	Female	1	1	1-11 1/2	Female NPT	2	97	(3.82)	53.3	(2.10)	42.9	(1.69)

Note: Incorporates a pusher device to open mating valved coupling halves.

Dimensions (Male Half, Female BSP/Valved)

Part Number Buna-N	Body Size	Thread	Fig.	Dimensions A		Dimensions B		Hex ①	
				mm	(in)	mm	(in)	mm	(in)
G5623-4-4	1/4	G 1/4	1	1.25	(31.8)	-	-	0.75	(19.0)
G5623-6-6	3/8	G 3/8	1	1.63	(41.5)	-	-	0.87	(22.0)
G5623-8-10	5/8	G 1/2	1	1.88	(47.7)	-	-	1.06	(27.0)
G5623-12-12	3/4	G 3/4	1	2.28	(58.0)	-	-	1.42	(36.0)
G5623-16-16	1	G 1	1	2.76	(70.0)	-	-	1.61	(41.0)

5600 Series

ISO 7241/1
Series A Interchange

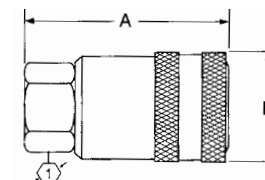

Figure 4

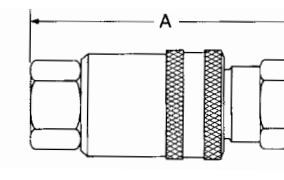

Figure 5

Dimensions (Female Half, Female BSP/Valved)

Part Number Buna-N	Body Size	Thread	Fig.	Dimensions				Hex ①	
				A	B	Hex ①			
				mm	(in)	mm	(in)	mm	(in)
G5622-4-4	1/4	G 1/4	2	1.81	(46.0)	1.04	(26.3)	0.87	(22.0)
G5622-6-6	3/8	G 3/8	2	2.33	(59.1)	1.21	(30.8)	1.06	(27.0)
G5622-8-10	5/8	G 1/2	2	2.76	(70.0)	1.51	(38.3)	1.26	(32.0)
G5622-12-12	3/4	G 3/4	2	3.32	(84.3)	1.83	(46.6)	1.61	(41.0)
G5622-16-16	1	G 1	2	4.07	(103.5)	2.15	(54.6)	1.97	(50.0)

Dimensions (Female NPT, Connect Under Pressure Style)

Part Number Buna-N	Viton	EPR	Coupling Type	Body Size	Port Size	Thread	Type	Fig.	Dimensions					
									A	B	Hex ①			
									mm	(in)	mm	(in)	mm	(in)
5602-8-10S	FD56-1062-08-10	5644-8-10S	Male	5/8	1/2	1/2-14	Female NPT Valved	1	51.3	(2.02)	-	-	26.9	(1.06)
5651-8-10S	FD56-1070-08-10	565007-8-10S	Female	5/8	1/2	1/2-14	Female NPT	4	73.2	(2.88)	38.1	(1.50)	26.9	(1.06)
5650-8-10S	FD56-1071-08-10	565006-8-10S	Complete	5/8	1/2	1/2-14	Female NPT	5	98.8	(3.89)	-	-	-	-
5602-12-10S	FD56-1062-12-10	5644-12-10S	Male	5/8	3/4	3/4-14	Female NPT Valved	1	54.9	(2.16)	-	-	35.1	(1.38)
5651-12-10S	FD56-1070-12-10	565007-12-10S	Female	5/8	3/4	3/4-14	Female NPT	4	83.8	(3.30)	38.1	(1.50)	31.8	(1.25)
5650-12-10S	FD56-1071-12-10	565006-12-10S	Complete	5/8	3/4	3/4-14	Female NPT	5	113	(4.45)	-	-	-	-

Dimensions (Female, SAE O-ring Valved)

Part Number Buna-N	Viton	EPR	Coupling Type	Body Size	Port Size	Thread	Type	Fig.	Dimensions					
									A	B	Hex ①			
									mm	(in)	mm	(in)	mm	(in)
5610-4-4S	FD56-1072-04-04	560078-4-4S	Male	1/4	7/16	7/16-20	Female SAE O-Ring	1	32.5	(1.28)	-	-	15.7	(.62)
5608-4-4S	FD56-1074-04-04	FD56-1012-04-04S	Female	1/4	7/16	7/16-20	Female SAE O-Ring	2	46	(1.81)	27.4	(1.08)	22.4	(.88)
5606-4-4S	FD56-1075-04-04	FD56-1009-04-04S	Complete	1/4	7/16	7/16-20	Female SAE O-Ring	3	64.3	(2.53)	-	-	-	-
5610-6-6S	FD56-1072-06-06	560078-6-6S	Male	3/8	9/16	9/16-18	Female SAE O-Ring	1	38.1	(1.50)	-	-	22.4	(.88)
5608-6-6S	FD56-1074-06-06	FD56-1012-06-06S	Female	3/8	9/16	9/16-18	Female SAE O-Ring	2	54.6	(2.15)	31.2	(1.23)	25.4	(1.00)
5606-6-6S	FD56-1075-06-06	FD56-1009-06-06S	Complete	3/8	9/16	9/16-18	Female SAE O-Ring	3	72.1	(2.84)	-	-	-	-
5610-8-10S	FD56-1072-08-10	560078-8-10S	Male	5/8	3/4	3/4-16	Female SAE O-Ring	1	51.6	(2.03)	-	-	26.9	(1.06)
5608-8-10S	FD56-1074-08-10	FD56-1012-08-10S	Female	5/8	3/4	3/4-16	Female SAE O-Ring	2	66.3	(2.61)	38.1	(1.50)	30.2	(1.19)
5606-8-10S	FD56-1075-08-10	FD56-1009-08-10S	Complete	5/8	3/4	3/4-16	Female SAE O-Ring	3	96	(3.78)	-	-	-	-
5610-10-10S	FD56-1072-10-10	560078-10-10S	Male	5/8	7/8	7/8-14	Female SAE O-Ring	1	52.8	(2.08)	-	-	28.4	(1.12)
5608-10-10S	FD56-1074-10-10	FD56-1012-10-10S	Female	5/8	7/8	7/8-14	Female SAE O-Ring	2	66.3	(2.61)	38.1	(1.50)	30.2	(1.19)
5606-10-10S	FD56-1075-10-10	FD56-1009-10-10S	Complete	5/8	7/8	7/8-14	Female SAE O-Ring	3	98.6	(3.88)	-	-	-	-
5610-12-12S	FD56-1072-12-12	560078-12-12S	Male	3/4	1 1/16	1 1/16-12	Female SAE O-Ring	1	64.8	(2.55)	-	-	35.1	(1.38)
5608-12-12S	FD56-1074-12-12	FD56-1012-12-12S	Female	3/4	1 1/16	1 1/16-12	Female SAE O-Ring	2	82.6	(3.25)	46	(1.81)	38.1	(1.50)
5606-12-12S	FD56-1075-12-12	FD56-1009-12-12S	Complete	3/4	1 1/16	1 1/16-12	Female SAE O-Ring	3	115.8	(4.56)	-	-	-	-
5610-16-16S	FD56-1072-16-16	560078-16-16S	Male	1	1 5/16	1 5/16-12	Female SAE O-Ring	1	78.7	(3.10)	-	-	41.1	(1.62)
5608-16-16S	FD56-1074-16-16	FD56-1012-16-16S	Female	1	1 5/16	1 5/16-12	Female SAE O-Ring	2	97.3	(3.83)	53.3	(2.10)	42.9	(1.69)
5606-16-16S	FD56-1075-16-16	FD56-1009-16-16S	Complete	1	1 5/16	1 5/16-12	Female SAE O-Ring	3	140.7	(5.54)	-	-	-	-

Dimensions (Female SAE O-ring, Valved with Sleeve Lock)

Part Number Buna-N	Viton	EPR	Coupling Type	Body Size	Port Size	Thread	Type	Fig.	Dimensions					
									A	B	Hex ①			
									mm	(in)	mm	(in)	mm	(in)
FD56-1270-06-06	-	-	Female	3/8	9/16	9/16-18	Female SAE O-Ring	3	54.6	(2.15)	31.8	(1.23)	25.4	(1.00)
FD56-1270-08-10	-	-	Female	5/8	3/4	3/4-16	Female SAE O-Ring	3	66.3	(2.61)	38.1	(1.50)	30.2	(1.19)
FD56-1270-12-12	-	-	Female	3/4	1 1/16	1 1/16-12	Female SAE O-Ring	3	82.6	(3.25)	46.7	(1.81)	38.1	(1.50)
FD56-1270-16-16	-	-	Female	1	1 5/16	1 5/16-12	Female SAE O-Ring	3	97.0	(3.82)	54.1	(2.10)	42.9	(1.69)

5600 Series

ISO 7241/1
Series A Interchange

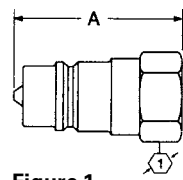

Figure 1

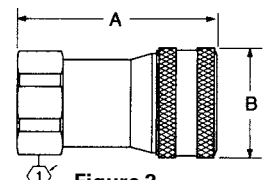

Figure 2

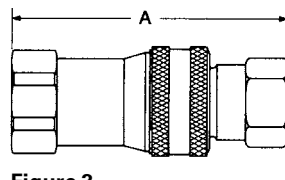

Figure 3

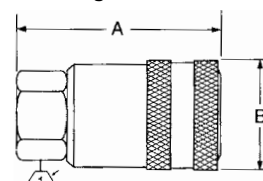

Figure 4

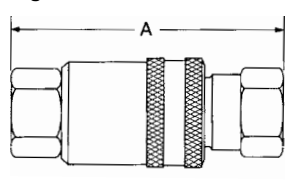

Figure 5

Dimensions (Female, SAE O-ring Non-Valved)

Part Number	Buna-N	Viton	EPR	Coupling Type	Body Size	Port Size	Thread	Type	Fig.	Dimensions					
										A	B	Hex ①			
										mm	(in)	mm	(in)	mm	(in)
5620-8-10S	FD56-1221-08-10	FD56-1221-08-10	Male	5/8	3/4	3/4-16	Female SAE O-Ring	1	48.0	(1.89)	25.9	(1.02)	26.9	(1.06)	
5691-8-10S	FD56-1233-08-10	FD56-1209-08-10	Female	5/8	3/4	3/4-16	Female SAE O-Ring	2	66.3	(2.61)	38.1	(1.50)	30.2	(1.19)	
5690-8-10S	FD56-1234-08-10	FD56-1210-08-10	Complete	5/8	3/4	3/4-16	Female SAE O-Ring	3	96.0	(3.78)	-	-	-	-	
5620-12-12S	FD56-1221-12-12	FD56-1221-12-12	Male	3/4	1 1/16	1 1/16-12	Female SAE O-Ring	1	57.9	(2.28)	30.7	(1.21)	35.1	(1.38)	
5691-12-12S	FD56-1233-12-12	FD56-1209-12-12	Female	3/4	1 1/16	1 1/16-12	Female SAE O-Ring	2	82.6	(3.25)	46.0	(1.81)	38.1	(1.50)	
5690-12-12S	FD56-1234-12-12	FD56-1210-12-12	Complete	3/4	1 1/16	1 1/16-12	Female SAE O-Ring	3	115.8	(4.56)	-	-	-	-	
5620-16-16S	FD56-1221-16-16	FD56-1221-16-16	Male	1	1 5/16	1 5/16-12	Female SAE O-Ring	1	70.4	(2.77)	36.8	(1.45)	41.1	(1.62)	
5691-16-16S	FD56-1233-16-16	FD56-1209-16-16	Female	1	1 5/16	1 5/16-12	Female SAE O-Ring	2	103.9	(4.09)	54.6	(2.15)	47.8	(1.88)	
5690-16-16S	FD56-1234-16-16	FD56-1210-16-16	Complete	1	1 5/16	1 5/16-12	Female SAE O-Ring	3	140.0	(5.51)	-	-	-	-	

Repair Kits

Part Number	Buna-N	Viton	EPR	Body Size
FF082-04*	FF092-04*	FF093-04*		1/4
FF082-06	FF092-06	FF093-06		3/8
FF082-10	FF092-10	FF093-10		5/8
FF082-12	FF092-12	FF093-12		3/4
FF082-16	FF092-16	FF093-16		1

Note: Each kit will repair one male or female half.

*The -02 coupling size valving is not repairable. This size repair kit contains an interface seal and back-up ring.



Dust Cap

Dust Caps

Part Number	Viton	Body Size
5654-4		1/4
5657-6		3/8
5657-10		5/8
5657-12		3/4
5657-16		1

Dust Plugs

Part Number	Viton	Body Size
5659-4		1/4
5659-6		3/8
5659-10		5/8
5659-12		3/4
5659-16		1

Break Away Frame

Part Number	Viton	Body Size
5603		-10



Break Away Frame



Dust Plug

FD86 Series

Thread to Connect
5,000 psi Dry Break – High Impulse



The FD86 Series is a thread together steel quick coupling offering dry break and high impulse technology and capabilities. The maximum operating pressure is 5,000 psi. The FD86 Series is available in either wing nut or hex nut configurations for ease of assembly and disassembly. (For higher pressure applications and additional size requirements, refer to FD96 on page 42.)

Product Features

- Tubular valve and sleeve construction for low fluid loss and air inclusion
- Thread together design using wing or hex nut allows connection and disconnection against pressures up to 750 psi
- Teflon* back-up rings along with secondary metal to-metal sealing contact provides high impulse capability up to 5,000 psi operating pressure
- Acme threads prevent galling and provide ease of connection
- Steel flange available for bulkhead mounting
- Standard seal material – Buna-N
- Standard body material – High resistance carbon steel with zinc trivalent plating

Physical Characteristics

Body Size	Max. Operating Pressure		Min. Burst Pressure		Vacuum Connected Only	Rated Flow	Air Inclusion	Fluid Loss
	bar	(psi)	bar	(psi)				
1	345	(5,000)	1,034	(15,000)	28	189 (50)	2.90 cc.max.	0.72 cc.max.
1/4	345	(5,000)	1,034	(15,000)	28	284 (75)	4.61 cc.max.	1.00 cc.max.



Applications

- Hydraulic and fluid transfer
- Mining equipment



Flow Data

Pressure Drop Versus Flow Graph

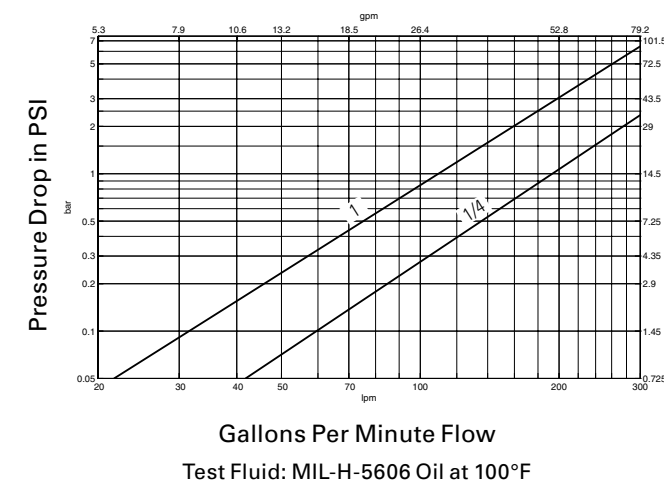

FD86 Series

Thread to Connect
5,000 psi Dry Break – High Impulse

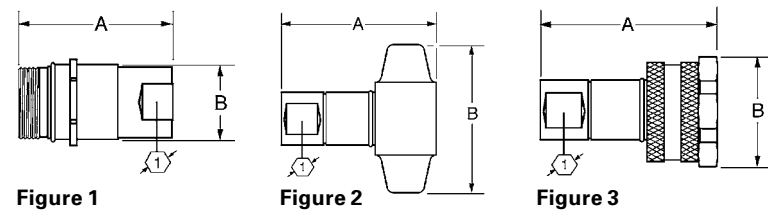

Dimensions (Female SAE O-ring)

Part Number	Buna-N	Viton	EPR	Type	Body Size	Port Size	Thread	Type	Fig.	Dimensions		Hex		
										A	B	mm	(in)	
FD86-1008-16-16	FD86-1043-16-16	FD86-1053-16-16	Male	1	1 5/16	1 5/16 - 12	Female SAE O-ring	1	102.4	(4.03)	53.6	(2.11)	44.5	(1.75)
FD86-1010-16-16	FD86-1044-16-16	FD86-1054-16-16	Female	1	1 5/16	1 5/16 - 12	Female SAE O-ring	2	117.3	(4.62)	114.3	(4.50)	-	-
FD86-1006-16-16	FD86-1042-16-16	FD86-1052-16-16	Female	1	1 5/16	1 5/16 - 12	Female SAE O-ring	3	117.3	(4.62)	71.4	(2.81)	15.8	(1.62)
FD86-1008-20-20	FD86-1043-20-20	FD86-1053-20-20	Male	1 1/4	1 5/8	1 5/8 - 12	Female SAE O-ring	1	105.7	(4.16)	63.0	(2.48)	57.2	(2.25)
FD86-1010-20-20	FD86-1044-20-20	FD86-1054-20-20	Female	1 1/4	1 5/8	1 5/8 - 12	Female SAE O-ring	2	132.6	(5.22)	133.4	(5.25)	-	-
FD86-1006-20-20	FD86-1042-20-20	FD86-1052-20-20	Female	1 1/4	1 5/8	1 5/8 - 12	Female SAE O-ring	3	132.6	(5.22)	86.4	(3.40)	50.8	(2.00)

Dimensions (Female NPT)

Part Number	Buna-N	Viton	EPR	Type	Body Size	Port Size	Thread	Type	Fig.	Dimensions		Hex		
										A	B	mm	(in)	
FD86-1002-16-16	FD86-1040-16-16	FD86-1050-16-16	Male	1	1 - 11 1/2	1 - 11 1/2	Female NPT	1	111.8	(4.40)	53.6	(2.11)	44.5	(1.75)
FD86-1001-16-16	FD86-1039-16-16	FD86-1049-16-16	Female	1	1 - 11 1/2	1 - 11 1/2	Female NPT	2	126.5	(4.98)	114.3	(4.50)	-	-
FD86-1004-16-16	FD86-1041-16-16	FD86-1051-16-16	Female	1	1 - 11 1/2	1 - 11 1/2	Female NPT	3	126.5	(4.98)	71.4	(2.81)	15.8	(1.62)
FD86-1002-20-20	FD86-1040-20-20	FD86-1050-20-20	Male	1 1/4	1 1/4 - 11 1/2	1 1/4 - 11 1/2	Female NPT	1	112.5	(4.43)	63.0	(2.48)	57.2	(2.25)
FD86-1001-20-20	FD86-1039-20-20	FD86-1049-20-20	Female	1 1/4	1 1/4 - 11 1/2	1 1/4 - 11 1/2	Female NPT	2	142.8	(5.62)	133.4	(5.25)	-	-
FD86-1004-20-20	FD86-1041-20-20	FD86-1051-20-20	Female	1 1/4	1 1/4 - 11 1/2	1 1/4 - 11 1/2	Female NPT	3	142.8	(5.62)	86.4	(3.40)	50.8	(2.00)

Repair Kits

Part Number	Buna-N	Viton	EPR	Body Size	Coupling Type
FF10596-16	FF10597-16	FF10598-16	1	Male	
FF10593-16	FF10594-16	FF10595-16	1	Female	
FF10596-20	FF10597-20	FF10598-20	1 1/4	Male	
FF10593-20	FF10594-20	FF10595-20	1 1/4	Female	

Dust Caps and Dust Plugs

Part Number	Dust Cap with Chain	Dust Plug with Chain	Body Size
FD86-1018-16	FD86-1016-16	1	
FD86-1018-20	FD86-1016-20	1 1/4	

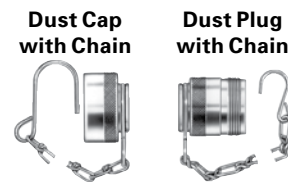

FD89 Series

ISO 16028 Interchange



Eaton's FD89 Series flush face is specifically designed for those applications where quick and easy connections and no-spill performance are essential. The FD89 is ideal for use where global interchangeability with other manufacturers is important and is available in sizes from 1/4" through 2" to best meet your specific size requirements. (For higher pressure applications and additional size requirements, refer to FD99 on page 44.)

Product Features

- Meets dimensional requirements of ISO 16028
- Push-to-connect latching
- Dual flush-face valving
- Anti-extrusion Teflon seal
- Safety sleeve lock
- Interchangeable with HTMA couplings (3/8")
- Standard seal material – Buna-N
- Standard body material – High resistance carbon steel with zinc trivalent plating

Physical Characteristics

ISO Size	Body Size	Max. Operating Pressure			Min. Burst Pressure			Rated Flow	Fluid Loss	Air Inclusion	Force to Connect								
		Connected	Male Half	Female Half	Connected	Male Half	Female Half												
(mm)		bar	(psi)	bar	(psi)	bar	(psi)	L/min	(gpm)	cc.	cc.	N	(lbs)						
6.3	1/4	300	(4,350)	300	(4,350)	120	(1,740)	1,200	(17,400)	1,200	(17,400)	480	(6,960)	12	(3.2)	0.006	0.005	179	(40.2)
10.0	3/8	300	(4,350)	300	(4,350)	120	(1,740)	1,200	(17,400)	1,200	(17,400)	480	(6,960)	23	(6.1)	0.012	0.280	173	(38.9)
12.5	1/2	250	(3,625)	250	(3,625)	100	(1,450)	1,000	(14,500)	1,000	(14,500)	400	(5,800)	45	(11.9)	0.020	0.040	181	(40.7)
16.0	3/4	250	(3,625)	220	(3,190)	100	(1,450)	1,000	(14,500)	880	(12,760)	400	(5,800)	74	(19.5)	0.026	0.270	195	(43.8)
19.0	1	250	(3,625)	200	(2,900)	100	(1,450)	1,000	(14,500)	800	(11,600)	400	(5,800)	100	(26.4)	0.032	0.040	224	(50.4)
25.0	1 1/4	250	(3,625)	200	(2,900)	100	(1,450)	1,000	(14,500)	800	(11,600)	400	(5,800)	189	(49.9)	0.010	0.140	304	(68.3)
31.5	1 1/2	200	(2,900)	160	(2,320)	80	(1,160)	800	(11,600)	640	(9,280)	320	(4,640)	288	(76.1)	0.050	0.980	427	(96.0)
40.0	2	200	(2,900)	160	(2,320)	80	(1,160)	800	(11,600)	640	(9,280)	320	(4,640)	379	(100.0)	N/A	N/A	488	(110.0)



Applications

- Hydraulic and fluid transfer
- Construction equipment
- Agricultural equipment
- Utility vehicles
- On-highway vehicles
- Stationary in-plant hydraulics and fluid transfer
- Interchangeable with HTMA couplings (3/8")

Flow Data

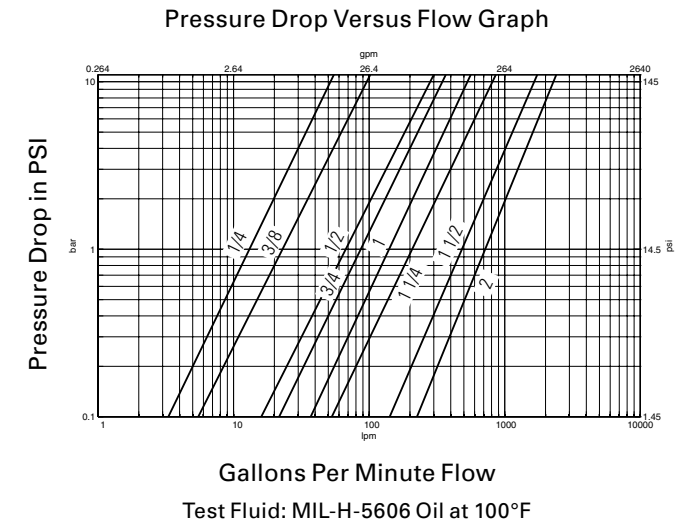

FD89 Series

ISO 16028 Interchange

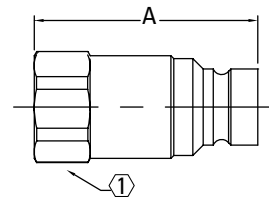

Figure 1

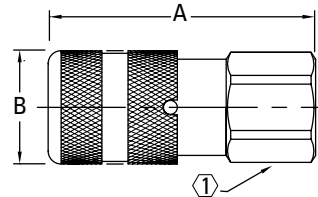

Figure 2

Dimensions (Female NPT)

Part Number	Coupling Type	Body Size	Port Size	Thread	Type	Fig.	Dimensions					
							A		B		Hex Ⓛ	
							mm	(in)	mm	(in)	mm	(in)
FD89-1001-04-04	Female	1/4	1/4	1/4 - 18	Female NPT	2	48.1	(1.89)	28.0	(1.10)	22	(0.86)
FD89-1002-04-04	Male	1/4	1/4	1/4 - 18	Female NPT	1	47.9	(1.88)			22	(0.86)
FD89-1001-06-06	Female	3/8	3/8	3/8 - 18	Female NPT	2	64.2	(2.53)	32.0	(1.26)	27	(1.06)
FD89-1002-06-06	Male	3/8	3/8	3/8 - 18	Female NPT	1	60.0	(2.36)			24	(0.94)
FD89-1001-08-06	Female	3/8	1/2	1/2 - 14	Female NPT	2	69.2	(2.72)	32.0	(1.26)	27	(1.06)
FD89-1002-08-06	Male	3/8	1/2	1/2 - 14	Female NPT	1	62.5	(2.46)			27	(1.06)
FD89-1001-08-08	Female	1/2	1/2	1/2 - 14	Female NPT	2	73.8	(2.91)	38.0	(1.49)	32	(1.26)
FD89-1002-08-08	Male	1/2	1/2	1/2 - 14	Female NPT	1	68.0	(2.67)			32	(1.26)
FD89-1001-12-08	Female	1/2	3/4	3/4 - 14	Female NPT	2	80.8	(3.18)	38.0	(1.49)	36	(1.42)
FD89-1002-12-08	Male	1/2	3/4	3/4 - 14	Female NPT	1	70.5	(2.78)			36	(1.42)
FD89-1001-12-12	Female	3/4	3/4	3/4 - 14	Female NPT	2	78.5	(3.09)	42.0	(1.65)	36	(1.42)
FD89-1002-12-12	Male	3/4	3/4	3/4 - 14	Female NPT	1	70.5	(2.78)			36	(1.42)
FD89-1001-16-16	Female	1	1	1 - 11 1/2	Female NPT	2	93.2	(3.67)	48.0	(1.89)	45	(1.77)
FD89-1002-16-16	Male	1	1	1 - 11 1/2	Female NPT	1	82.3	(3.24)			45	(1.77)
FD89-1001-20-20	Female	1 1/4	1 1/4	1 1/4 - 11 1/2	Female NPT	2	106.0	(4.17)	55.0	(2.17)	55	(2.17)
FD89-1002-20-20	Male	1 1/4	1 1/4	1 1/4 - 11 1/2	Female NPT	1	89.8	(3.54)			55	(2.17)
FD89-1001-24-24	Female	1 1/2	1 1/2	1 1/2 - 11 1/2	Female NPT	2	132.4	(5.21)	80.0	(3.15)	65	(2.56)
FD89-1002-24-24	Male	1 1/2	2	1 1/2 - 11 1/2	Female NPT	1	111.1	(4.37)			65	(2.56)
FD89-1001-32-32	Female	2	2	2 - 11 1/2	Female NPT	2	156.6	(6.17)	100.0	(3.94)	80	(3.15)
FD89-1002-32-32	Male	2	2	2 - 11 1/2	Female NPT	1	123.8	(4.87)			75	(2.95)

Dimensions (Female BSP)

Part Number	Coupling Type	Body Size	Port Size	Thread	Type	Fig.	Dimensions					
							A		B		Hex Ⓛ	
							mm	(in)	mm	(in)	mm	(in)
FD89-1006-04-04	Female	1/4	1/4	G 1/4	Female BSP	2	48.1	(1.89)	28.0	(1.10)	22	(0.86)
FD89-1007-04-04	Male	1/4	1/4	G 1/4	Female BSP	1	47.9	(1.88)			22	(0.86)
FD89-1006-06-06	Female	3/8	3/8	G 3/8	Female BSP	2	64.2	(2.53)	32.0	(1.26)	27	(1.06)
FD89-1007-06-06	Male	3/8	3/8	G 3/8	Female BSP	1	60.0	(2.36)			24	(0.94)
FD89-1006-08-06	Female	3/8	1/2	G 1/2	Female BSP	2	69.2	(2.72)	32.0	(1.26)	27	(1.06)
FD89-1007-08-06	Male	3/8	1/2	G 1/2	Female BSP	1	62.5	(2.46)			27	(1.06)
FD89-1006-08-08	Female	1/2	1/2	G 1/2	Female BSP	2	73.8	(2.91)	38.0	(1.49)	32	(1.26)
FD89-1007-08-08	Male	1/2	1/2	G 1/2	Female BSP	1	68.0	(2.67)			32	(1.26)
FD89-1006-12-08	Female	1/2	3/4	G 3/4	Female BSP	2	80.8	(3.18)	38.0	(1.49)	36	(1.42)
FD89-1007-12-08	Male	1/2	3/4	G 3/4	Female BSP	1	70.5	(2.78)			36	(1.42)
FD89-1006-12-12	Female	3/4	3/4	G 3/4	Female BSP	2	78.5	(3.09)	42.0	(1.65)	36	(1.42)
FD89-1007-12-12	Male	3/4	3/4	G 3/4	Female BSP	1	70.5	(2.78)			36	(1.42)
FD89-1006-16-16	Female	1	1	G 1	Female BSP	2	93.2	(3.67)	48.0	(1.89)	45	(1.77)
FD89-1007-16-16	Male	1	1	G 1	Female BSP	1	82.3	(3.24)			45	(1.77)
FD89-1006-20-20	Female	1 1/4	1 1/4	G 1 1/4	Female BSP	2	106.0	(4.17)	55.0	(2.17)	55	(2.17)
FD89-1007-20-20	Male	1 1/4	1 1/4	G 1 1/4	Female BSP	1	89.9	(3.54)			55	(2.17)
FD89-1006-24-24	Female	1 1/2	1 1/2	G 1 1/2	Female BSP	2	132.4	(5.21)	80.0	(3.15)	65	(2.56)
FD89-1007-24-24	Male	1 1/2	1 1/2	G 1 1/2	Female BSP	1	111.1	(4.37)			65	(2.56)
FD89-1006-32-32	Female	2	2	G 2	Female BSP	2	156.6	(6.17)	100.0	(3.94)	80	(3.15)
FD89-1007-32-32	Male	2	2	G 2	Female BSP	1	123.8	(4.87)			75	(2.95)

FD89 Series

ISO 16028 Interchange

Dimensions (Female SAE O-ring)

Part Number	Coupling Type	Body Size	Port Size	Thread	Type	Fig.	Dimensions					
							A		B		Hex Ⓛ	
							mm	(in)	mm	(in)	mm	(in)
FD89-1005-06-04	Female	1/4	9/16	9/16 - 18 UNF	Female SAE O-ring	2	53.1	(2.09)	28.0	(1.10)	22	(0.86)
FD89-1004-06-04	Male	1/4	9/16	9/16 - 18 UNF	Female SAE O-ring	1	50.9	(2.00)			22	(0.86)
FD89-1005-08-06	Female	3/8	3/4	3/4 - 16 UNF	Female SAE O-ring	2	69.2	(2.72)	32.0	(1.26)	27	(1.06)
FD89-1004-08-06	Male	3/8	3/4	3/4 - 16 UNF	Female SAE O-ring	1	62.5	(2.46)			27	(1.06)
FD89-1005-10-06	Female	3/8	7/8	7/8 - 14 UNF	Female SAE O-ring	2	71.2	(2.80)	32.0	(1.26)	30	(1.18)
FD89-1004-10-06	Male	3/8	7/8	7/8 - 14 UNF	Female SAE O-ring	1	64.0	(2.52)			30	(1.18)
FD89-1005-10-08	Female	1/2	7/8	7/8 - 14 UNF	Female SAE O-ring	2	76.3	(3.00)	38.0	(1.49)	32	(1.26)
FD89-1004-10-08	Male	1/2	7/8	7/8 - 14 UNF	Female SAE O-ring	1	70.0	(2.76)			32	(1.26)
FD89-1005-12-08	Female	1/2	1 1/16	1 1/16 - 12 UN	Female SAE O-ring	2	83.3	(3.28)	38.0	(1.49)	36	(1.42)
FD89-1004-12-08	Male	1/2	1 1/16	1 1/16 - 12 UN	Female SAE O-ring	1	72.0	(2.83)			36	(1.42)
FD89-1005-12-12	Female	3/4	1 1/16	1 1/16 - 12 UN	Female SAE O-ring	2	83.5	(3.29)	42.0	(1.65)	36	(1.42)
FD89-1004-12-12	Male	3/4	1 1/16	1 1/16 - 12 UN	Female SAE O-ring	1	72.0	(2.83)			36	(1.42)
FD89-1005-16-16	Female	1	1 5/16	1 5/16 - 12 UN	Female SAE O-ring	2	93.2	(3.67)	48.0	(1.89)	45	(1.77)
FD89-1004-16-16	Male	1	1 5/16	1 5/16 - 12 UN	Female SAE O-ring	1	82.3	(3.24)			45	(1.77)
FD89-1005-20-20	Female	1 1/4	1 5/8	1 5/8 - 12 UN	Female SAE O-ring	2	106.0	(4.17)	55.0	(2.17)	55	(2.17)
FD89-1004-20-20	Male	1 1/4	1 5/8	1 5/8 - 12 UN	Female SAE O-ring	1	89.8	(3.54)			55	(2.17)
FD89-1005-24-24	Female	1 1/2	1 7/8	1 7/8 - 12 UN	Female SAE O-ring	2	132.4	(5.21)	80.0	(3.15)	65	(2.56)
FD89-1004-24-24	Male	1 1/2	2	1 7/8 - 12 UN	Female SAE O-ring	1	111.1	(4.37)			65	(2.56)
FD89-1005-32-32	Female	2	2 1/2	2 1/2 - 12 UN	Female SAE O-ring	2	156.6	(6.17)	100.0	(3.94)	80	(3.15)
FD89-1004-32-32	Male	2	2 1/2	2 1/2 - 12 UN	Female SAE O-ring	1	123.8	(4.87)			75	(2.95)

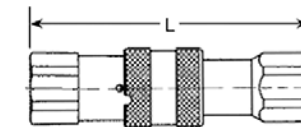

Dimensions — Connected Length

Body Size	Dimensions NPT & BSP		SAE O-ring	
	mm	(in)	mm	(in)
1/4	85.5	(3.37)		
3/8 - 1/4			93.2	(3.67)
3/8 - 3/8	109.0	(4.29)		
1/2 - 3/8	116.5	(4.59)	116.2	(4.57)
1/2 - 1/2	125.0	(4.92)		
5/8 - 3/8			119.7	(4.71)
5/8 - 1/2			129.1	(5.08)
3/4 - 1/2	134.5	(5.30)	138.1	(5.44)
3/4	132.0	(5.2)	138.0	(5.43)
1	154.0	(6.06)	153.7	(6.05)
1 1/4	173.0	(6.81)	172.8	(6.80)
1 1/2	215.0	(8.46)	215.2	(8.47)
2	241.5	(9.51)	241.6	(9.51)

Female Half Dust Caps

Part Number	Coupling Type	Body Size	Cap Material
FD89-1009-04	Female	1/4	PVC
FD89-1009-06	Female	3/8	PVC
FD89-1009-08-08	Female	1/2, 1/2	PVC
FD89-1009-12-08	Female	3/4, 1/2	PVC
FD89-1009-12	Female	3/4	PVC
FD89-1009-16	Female	1	PVC
FD89-1009-20	Female	1 1/4	PVC

Male Half Dust Cap

Part Number	Coupling Type	Body Size	Cap Material
FD89-1008-04	Male	1/4	PVC
FD89-1008-06-06	Male	3/8, 3/8	PVC
FD89-1008-08-06	Male	1/2, 3/8	PVC
FD89-1008-08-08	Male	1/2, 1/2	PVC
FD89-1008-12-08	Male	3/4, 1/2	PVC
FD89-1008-12	Male	3/4	PVC
FD89-1008-16	Male	1	PVC
FD89-1008-20	Male	1 1/4	PVC

FD89 - 2000 Series

316 Stainless Steel
ISO 16028 Interchange



Product Features

- Meets dimensional requirements of ISO 16028
- Push-to-connect latching
- Dual flush-face valving with non-spill design
- Safety sleeve lock
- Anti-extrusion Teflon® seal
- Body material – 316 stainless steel
- Standard seal material – Viton, other material available on request

The FD89 Stainless Steel Series is designed for those applications where quick and easy connections and non-spill performance are critical. Ideal for use where global interchangeability with other manufactures is important. The 316 stainless steel material is suitable for applications where high corrosion resistance and long product life is essential. The FD89 2000 Series is available in sizes 1/4" through 2" to best meet your specific size requirements.

Physical Characteristics

ISO Size	Body Size	Max. Operating Pressure			Min. Burst Pressure			Rated Flow	Fluid Loss	Force to Connect
		Connected	Male Half	Female Half	Connected	Male Half	Female Half			
6.3	1/4	350 (5,075)	350 (5,075)	120 (1,740)	1,400 (20,300)	1,200 (17,400)	480 (6,960)	12 (3.2)	.006	160 (36)
10.0	3/8	350 (5,075)	350 (5,075)	150 (2,175)	1,400 (20,300)	1,200 (17,400)	600 (8,700)	23 (6.1)	.012	160 (36)
12.5	1/2	350 (5,075)	350 (5,075)	150 (2,175)	1,200 (17,400)	1,100 (15,950)	600 (8,700)	45 (11.9)	.020	200 (45)
16.0	5/8	350 (5,075)	300 (4,350)	120 (1,740)	1,200 (17,400)	1,000 (14,500)	480 (6,960)	74 (19.6)	.026	200 (45)
19.0	3/4	330 (4,785)	230 (4,060)	120 (1,740)	1,000 (14,500)	800 (11,600)	480 (6,960)	100 (26.5)	.032	200 (45)
25.0	1	280 (4,060)	280 (4,060)	120 (1,740)	900 (13,050)	800 (11,600)	480 (6,960)	189 (50.1)	.035	280 (63)
31.5	1 1/4	230 (3,335)	230 (3,335)	80 (1,160)	800 (11,600)	700 (10,150)	320 (4,640)	288 (76.3)	.050	580 (131)
40.0	2	150 (2,175)	150 (2,175)	70 (1,015)	600 (8,700)	600 (8,700)	280 (4,060)	379 (100.5)	.100	490 (110)



Applications

- Hydraulic fluid transfer
- Chemical processing
- Pharmaceutical transfer
- Oil field



Flow Data

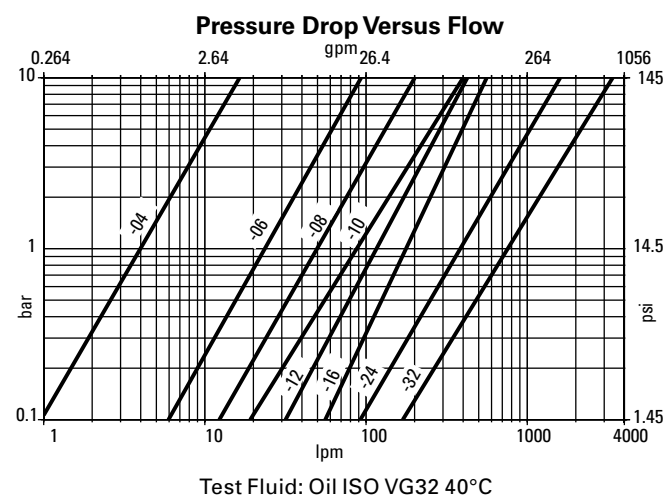

FD89 - 2000 Series

316 Stainless Steel
ISO 16028 Interchange

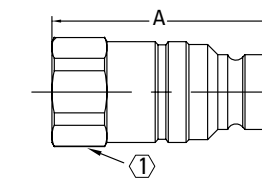

Figure 1

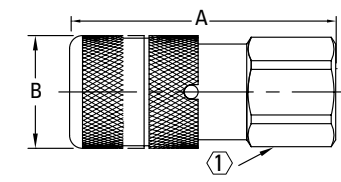
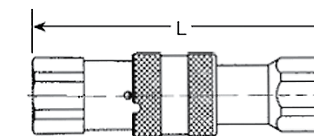

Figure 2

Dimensions

Part Number	Coupling Type	Body Size	Port Thread	Type	Fig. A	Dimensions B		Hex ①	
						mm	(in)	mm	(in)
FD89-2001-04-04	Female	1/4	1/4	1/4-18	Female NPT	2	48,3 (1.90)	28,0 (1.10)	22 (.87)
FD89-2002-04-04	Male	1/4	1/4	1/4-18	Female NPT	1	47,9 (1.89)		22 (.87)
FD89-2001-06-06	Female	3/8	3/8	3/8-18	Female NPT	2	64,2 (2.53)	32,0 (1.26)	27 (1.06)
FD89-2002-06-06	Male	3/8	3/8	3/8-18	Female NPT	1	60,0 (2.36)		24 (.94)
FD89-2001-08-08	Female	1/2	1/2	1/2-14	Female NPT	2	73,8 (2.91)	38,0 (1.50)	32 (1.26)
FD89-2002-08-08	Male	1/2	1/2	1/2-14	Female NPT	1	68,0 (2.68)		32 (1.26)
FD89-2001-12-10	Female	5/8	3/4	3/4-14	Female NPT	2	80,9 (3.19)	42,0 (1.65)	36 (1.42)
FD89-2002-12-10	Male	5/8	3/4	3/4-14	Female NPT	1	70,5 (2.78)		36 (1.42)
FD89-2001-16-12	Female	3/4	1	1-11 1/2	Female NPT	2	92,9 (3.67)	48,0 (1.89)	46 (1.81)
FD89-2002-16-12	Male	3/4	1	1-11 1/2	Female NPT	1	82,2 (3.24)		46 (1.81)
FD89-2001-20-16	Female	1	1 1/4	1 1/4-11 1/2	Female NPT	2	106,2 (4.18)	55,0 (2.17)	55 (2.17)
FD89-2002-20-16	Male	1	1 1/4	1 1/4-11 1/2	Female NPT	1	90,0 (3.54)		55 (2.17)
FD89-2001-24-24	Female	1 1/2	1 1/2	1 1/2-11 1/2	Female NPT	2	132,4 (5.21)	80,0 (3.15)	65 (2.56)
FD89-2002-24-24	Male	1 1/2	1 1/2	1 1/2-11 1/2	Female NPT	1	111,0 (4.37)		70 (2.76)
FD89-2001-32-32	Female	2	2	2-11 1/2	Female NPT	2	156,6 (6.17)	100,0 (3.94)	80 (3.15)
FD89-2002-32-32	Male	2	2	2-11 1/2	Female NPT	1	123,8 (4.87)		75 (2.95)

Connected Length



Body Size	Port Size	Connected Length "L"	
		mm	(in)
1/4	1/4	85,2	(3.35)
3/8	3/8	108,6	(4.28)
1/2	1/2	124,5	(4.90)
5/8	3/4	133,8	(5.27)
3/4	1	153,3	(6.04)
1	1 1/4	173,0	(6.81)
1 1/2	1 1/2	214,8	(8.46)
2	2	241,5	(9.51)

Dust Caps and Dust Plugs

Body Size	Part Number	Coupling Type	Cap Material
1/4 - 1/4	FD89-1009-04	Female	PVC
3/8 - 3/8	FD89-1009-06	Female	PVC
1/2 - 1/2	FD89-1009-08-08	Female	PVC
3/4 - 5/8	FD89-1009-12	Female	PVC
1 - 3/4	FD89-1009-16	Female	PVC
1 1/4 - 1	FD89-1009-20	Female	PVC
1 1/2 - 1 1/2	FD89-1009-24	Female	Aluminum
2 - 2	FD89-1009-32	Female	Aluminum

Body Size	Part Number	Coupling Type	Cap Material
1/4 - 1/4	FD89-1008-04	Male	PVC
3/8 - 3/8	FD89-1008-06-06	Male	PVC
1/2 - 1/2	FD89-1008-08-08	Male	PVC
3/4 - 5/8	FD89-1008-12	Male	PVC
1 - 3/4	FD89-1008-16	Male	PVC
1 1/4 - 1	FD89-1008-20	Male	PVC
1 1/2 - 1 1/2	FD89-1008-24	Male	Aluminum
2 - 2	FD89-1008-32	Male	Aluminum

FD96 Series

High Pressure Thread to Connect to Flush Face



Product Features

- Thread together design allows connection and disconnection under pressure up to 4,300 psi
- Low connection force
- Dual flush-face valving with non-spill design
- Working pressures up to 8,500 psi
- Body material – High resistance carbon steel with zinc trivalent chromate plating and black oxide plating

The FD96 High Pressure Thread Together Flush Face Series is designed for high pressure and high impulse applications for hydraulic circuits. The FD96 design provides low connect and disconnect force in hydraulic circuits where trapped residual pressure must be addressed. The flush face design limits contamination and unwanted fluid loss. The FD96 Series is available in sizes 1/4" through 2" to best meet your specific size requirements.

Applications

- Hydraulic fluid transfer
- High impulse hydraulics
- Oil field
- Mining



Physical Characteristics

Body Size	Max. Operating Pressure			Min. Burst Pressure			Rated Flow	Fluid Loss	Req. Torque to Connect
	Connected	Male Half	Female Half	Connected	Male Half	Female Half			
1/4	600 (8,700)	600 (8,700)	420 (6,090)	1,500 (21,750)	1,500 (21,750)	1,260 (18,270)	12 (3.2)	.012	29-37 (40-50)
3/8	550 (7,980)	550 (7,980)	330 (4,785)	1,400 (20,300)	1,400 (20,300)	1,000 (14,500)	23 (6.1)	.040	37-44 (50-60)
1/2	550 (7,980)	550 (7,980)	330 (4,785)	1,400 (20,300)	1,400 (20,300)	1,000 (14,500)	45 (11.9)	.025	48-55 (65-75)
3/4	550 (7,980)	550 (7,980)	330 (4,785)	1,400 (20,300)	1,400 (20,300)	1,000 (14,500)	74 (19.6)	.033	52-59 (70-80)
1	500 (7,250)	500 (7,250)	330 (4,785)	1,250 (18,125)	1,250 (18,125)	1,000 (14,500)	100 (26.5)	.018	66-81 (90-110)
1 1/4	470 (6,800)	470 (6,800)	300 (4,350)	1,200 (17,400)	1,200 (17,400)	800 (11,600)	189 (50.1)	.060	92-107 (125-145)
1 1/2	400 (5,800)	400 (5,800)	270 (3,915)	1,700 (15,950)	1,100 (15,950)	800 (11,600)	288 (76.3)	.200	114-129 (155-175)
2	350 (5,080)	350 (5,080)	270 (3,915)	1,100 (15,950)	1,100 (15,950)	800 (11,600)	379 (100.4)	.350	236-258 (320-355)

Flow Data

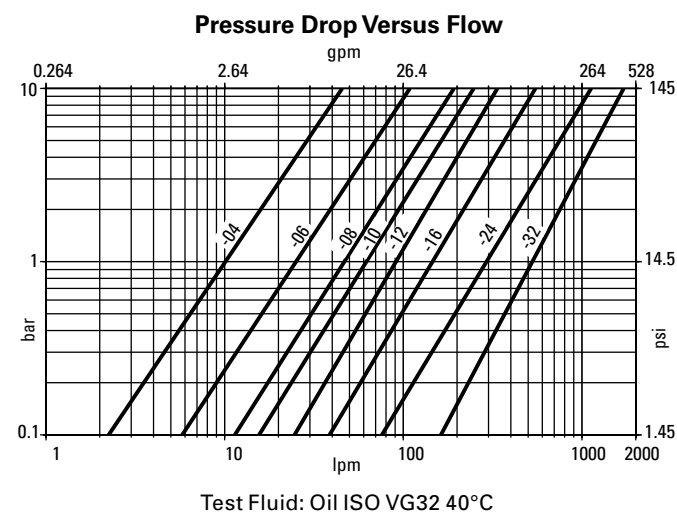

Connected Length

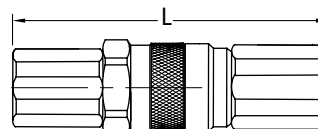

Body Size	Port Size	Connected Length "L"
		mm (in)
1/4	3/8	90,0 (3.54)
3/8	3/8	131,0 (5.16)
3/8	1/2	131,0 (5.16)
1/2	1/2	155,0 (6.10)
1/2	3/4	160,0 (6.30)
3/4	3/4	165,0 (6.50)
1	1	190,4 (7.50)
1	1 1/4	170,0 (6.69)
1 1/2	1 1/2	256,0 (10.08)
2	2	363,5 (14.31)

FD96 Series

High Pressure Thread to Connect to Flush Face

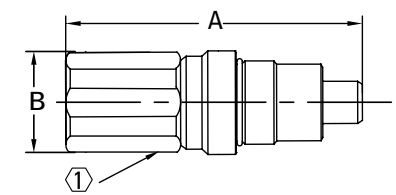

Figure 1

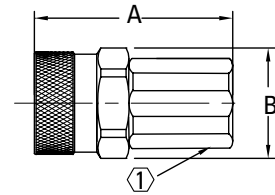

Figure 2

Dimensions (Female NPT)

Part Number	Coupling Type	Body Size	Port Size	Thread	Type	Fig.	Dimensions			Hex ①	
							A	B	Hex	A	B
FD96-1001-06-06	Female	3/8	3/8	3/8-18	Female NPT	2	65,8 (2.59)	41,8 (1.65)	30 (1.18)	30 (1.18)	30 (1.18)
FD96-1002-06-06	Male	3/8	3/8	3/8-18	Female NPT	1	82,5 (3.25)	37,8 (1.49)	27 (1.06)	27 (1.06)	27 (1.06)
FD96-1001-08-06	Female	3/8	1/2	1/2-14	Female NPT	2	70,8 (2.79)	41,8 (1.65)	30 (1.18)	30 (1.18)	30 (1.18)
FD96-1002-08-06	Male	3/8	1/2	1/2-14	Female NPT	1	85,0 (3.35)	37,8 (1.49)	27 (1.06)	27 (1.06)	27 (1.06)
FD96-1001-08-08	Female	1/2	1/2	1/2-14	Female NPT	2	77,8 (3.06)	49,8 (1.96)	36 (1.42)	36 (1.42)	36 (1.42)
FD96-1002-08-08	Male	1/2	1/2	1/2-14	Female NPT	1	95,0 (3.74)	45,8 (1.80)	36 (1.42)	36 (1.42)	36 (1.42)
FD96-1001-12-08	Female	1/2	3/4	3/4-14	Female NPT	2	84,8 (3.06)	49,8 (1.96)	36 (1.42)	36 (1.42)	36 (1.42)
FD96-1002-12-08	Male	1/2	3/4	3/4-14	Female NPT	1	97,4 (3.83)	45,8 (1.80)	36 (1.42)	36 (1.42)	36 (1.42)
FD96-1001-12-12	Female	3/4	3/4	3/4-14	Female NPT	2	84,9 (3.34)	53,8 (2.12)	41 (1.61)	41 (1.61)	41 (1.61)
FD96-1002-12-12	Male	3/4	3/4	3/4-14	Female NPT	1	99,0 (3.90)	49,8 (1.96)	36 (1.42)	36 (1.42)	36 (1.42)
FD96-1001-12-16	Female	1	3/4	3/4-14	Female NPT	2	96,7 (3.81)	58,8 (2.31)	46 (1.81)	46 (1.81)	46 (1.81)
FD96-1002-12-16	Male	1	3/4	3/4-14	Female NPT	1	113,6 (4.47)	54,8 (2.16)	46 (1.81)	46 (1.81)	46 (1.81)
FD96-1001-16-16	Female	1	1	1-11 1/2	Female NPT	2	99,7 (3.93)	58,8 (2.31)	46 (1.81)	46 (1.81)	46 (1.81)
FD96-1002-16-16	Male	1	1	1-11 1/2	Female NPT	1	113,6 (4.47)	54,8 (2.16)	46 (1.81)	46 (1.81)	46 (1.81)
FD96-1001-16-20	Female	1 1/4	1	1-11 1/2	Female NPT	2	105,8 (4.17)	69,8 (2.75)	55 (2.17)	55 (2.17)	55 (2.17)
FD96-1002-16-20	Male	1 1/4	1	1-11 1/2	Female NPT	1	123,4 (4.86)	64,5 (2.54)	55 (2.17)	55 (2.17)	55 (2.17)
FD96-1001-20-20	Female	1 1/4	1 1/4	1 1/4-11 1/2	Female NPT	2	106,8 (4.20)	69,8 (2.75)	55 (2.17)	55 (2.17)	55 (2.17)
FD96-1002-20-20	Male	1 1/4	1 1/4	1 1/4-11 1/2	Female NPT	1	123,4 (4.86)	64,5 (2.54)	55 (2.17)	55 (2.17)	55 (2.17)
FD96-1001-20-24	Female	1 1/2	1 1/4	1 1/4-11 1/2	Female NPT	2	133,5 (5.26)	92,0 (3.62)	65 (2.56)	65 (2.56)	65 (2.56)
FD96-1002-20-24	Male	1 1/2	1 1/4	1 1/4-11 1/2	Female NPT	1	150,0 (5.91)	89,8 (3.54)	65 (2.56)	65 (2.56)	65 (2.56)
FD96-1001-24-24	Female	1 1/2	1 1/2	1 1/2-11 1/2	Female NPT	2	133,5 (5.26)	92,0 (3.62)	65 (2.56)	65 (2.56)	65 (2.56)
FD96-1002-24-24	Male	1 1/2	1 1/2	1 1/2-11 1/2	Female NPT	1	150,0 (5.91)	89,8 (3.54)	65 (2.56)	65 (2.56)	65 (2.56)
FD96-1001-32-32	Female	2	2	2-11 1/2	Female NPT	2	224,8 (8.85)	200,0 (7.87)	90 (3.54)	90 (3.54)	90 (3.54)
FD96-1002-32-32	Male	2	2	2-11 1/2	Female NPT	1	218,4 (8.60)	145,0 (5.71)	90 (3.54)	90 (3.54)	90 (3.54)

Dimensions (Female SAE O-ring)

Part Number	Coupling Type	Body Size	Port Size	Thread	Type	Fig.	Dimensions			Hex ①	
							A	B	Hex	A	B
FD96-1004-06-04	Female	1/4	3/8	9/16-18 UNF	Female SAE O-ring	2	57,1 (2.25)	38,8 (1.53)	27 (1.06)	27 (1.06)	27 (1.06)
FD96-1005-06-04	Male	1/4	3/8	9/16-18 UNF	Female SAE O-ring	1	72,8 (2.87)	34,8 (1.37)	22 (.87)	22 (.87)	22 (.87)
FD96-1004-08-06	Female	3/8	1/2	3/4-16 UNF	Female SAE O-ring	2	70,8 (2.79)	41,8 (1.65)	30 (1.18)	30 (1.18)	30 (1.18)
FD96-1005-08-06	Male	3/8	1/2	3/4-16 UNF	Female SAE O-ring	1	87,0 (3.43)	37,8 (1.49)	27 (1.06)	27 (1.06)	27 (1.06)
FD96-1004-12-08	Female	1/2	3/4	11/16-12 UNF	Female SAE O-ring	2	84,8 (3.06)	49,8 (1.96)	36 (1.42)	36 (1.42)	36 (1.42)
FD96-1005-12-08	Male	1/2	3/4	11/16-12 UNF	Female SAE O-ring	1	100,4 (3.95)	45,8 (1.80)	36 (1.42)	36 (1.42)	36 (1.42)
FD96-1004-12-12	Female	3/4	3/4	11/16-12 UNF	Female SAE O-ring	2	84,9 (3.34)	53,8 (2.12)	41 (1.61)	41 (1.61)	41 (1.61)
FD96-1005-12-12	Male	3/4	3/4	11/16-12 UN	Female SAE O-ring	1	102,0 (4.02)	49,8 (1.96)	36 (1.42)	36 (1.42)	36 (1.42)
FD96-1004-12-16	Female	1	3/4	11/16-12 UN	Female SAE O-ring	2	99,7 (3.93)	58,8 (2.31)	46 (1.81)	46 (1.81)	46 (1.81)
FD96-1005-12-16	Male	1	3/4	11/16-12 UN	Female SAE O-ring	1	115,6 (4.55)	54,8 (2.16)	46 (1.81)	46 (1.81)	46 (1.81)
FD96-1004-16-16	Female	1	1	15/16-12 UN	Female SAE O-ring	2	99,7 (3.93)	58,8 (2.31)	46 (1.81)	46 (1.81)	46 (1.81)
FD96-1005-16-16	Male	1	1	15/16-12 UN	Female SAE O-ring	1	113,6 (4.47)	54,8 (2.16)	46 (1.81)	46 (1.81)	46 (1.81)
FD96-1004-16-20	Female	1 1/4	1	15/16-12 UN	Female SAE O-ring	2	105,8 (4.17)	69,8 (2.75)	55 (2.17)	55 (2.17)	55 (2.17)
FD96-1005-16-20	Male	1 1/4	1	15/16-12 UN	Female SAE O-ring	1	125,4 (4.94)	64,5 (2.54)	55 (2.17)	55 (2.17)	55 (2.17)
FD96-1004-20-20	Female	1 1/4	1 1/4	15/8-12 UN	Female SAE O-ring	2	106,8 (4.20)	69,8 (2.75)	55 (2.17)	55 (2.17)	55 (2.17)
FD96-1005-20-20	Male	1 1/4	1 1/4	15/8-12 UN	Female SAE O-ring	1	123,4 (4.86)	64,5 (2.54)	55 (2.17)	55 (2.17)	55 (2.17)
FD96-1004-20-24	Female	1 1/2	1 1/4	15/8-12 UN	Female SAE O-ring	2	133,5 (5.26)	92,0 (3.62)	65 (2.56)	65 (2.56)	65 (2.56)
FD96-1005-20-24	Male	1 1/2	1 1/4	15/8-12 UN	Female SAE O-ring	1	150,0 (5.91)	89,8 (3.54)	65 (2.56)	65 (2.56)	65 (2.56)
FD96-1004-24-24	Female	1 1/2	1 1/2	17/8-12 UN	Female SAE O-ring	2	133,5 (5.26)	92,0 (3.62)	65 (2.56)	65 (2.56)	65 (2.56)
FD96-1005-24-24	Male	1 1/2	1 1/2	17/8-12 UN	Female SAE O-ring	1	150,0 (5.91)	89,8 (3.54)	65 (2.56)	65 (2.56)	65 (2.56)
FD96-1004-32-32	Female	2	2	2 1/2-12 UN	Female SAE O-ring	2	224,8 (8.85)	200,0 (7.87)	90 (3.54)	90 (3.54)	90 (3.54)
FD96-1005-32-32	Male	2	2	2 1/2-12 UN	Female SAE O-ring	1	218,4 (8.60)	145,0 (5.71)	90 (3.54)	90 (3.54)	90 (3.54)

Dust Caps and Dust Plugs

Body Size	Part Number	Coupling Type	Cap Material	Body Size	Part Number	Coupling Type	Cap Material
1/4	FD96-1009-04	Female	Aluminum	1/4	FD96-1010-04	Male	Aluminum
3/8	FD96-1009-06	Female	Aluminum	3/8	FD96-1010-06	Male	Aluminum
1/2	FD96-1009-08	Female	Aluminum	1/2	FD96-1010-08	Male	Aluminum
3/4	FD96-1009-12	Female	Aluminum	3/4	FD96-1010-12	Male	Aluminum
1	FD96-1009-16	Female	Aluminum	1	FD96-1010-16	Male	Aluminum
1 1/4	FD96-1009-20	Female	Aluminum	1 1/4	FD96-1010-20	Male	Aluminum
1 1/2	FD96-1009-24	Female	Aluminum	1 1/2	FD96-1010-24	Male	Aluminum
2	FD96-1009-32	Female	Aluminum	2	FD96-1010-32	Male	Aluminum

FD99 Series

High Pressure Flush Face
ISO 16028 Interchange



The FD99 High Pressure Flush Face Series is designed for those applications where quick and easy connections and non-spill performance are critical. Ideal for use where global interchangeability and high pressure applications are a must. The high pressure design and reduced pressure drop exceeds industry standards for ISO 16028 standards. The FD99 Series is available in sizes from 1/4" through 1-1/2" to best meet your specific size requirements.

Product Features

- Meets dimensional requirements of ISO 16028
- Push-to-connect latching
- Dual flush-face valving with non-spill design
- Safety sleeve lock
- Anti-extrusion Teflon® seal
- Body material – High resistance carbon steel with zinc trivalent chromate plating
- Standard seal material – Nitrile/Teflon®, additional material available on request

Physical Characteristics

ISO Size	Body Size	Max. Operating Pressure				lin. Burst Pressure				Rated Flow	Fluid Loss	Force to Connect						
		Connected		Male Half		Female Half		Connected					Male Half		Female Half			
		bar	(psi)	bar	(psi)	bar	(psi)	bar	(psi)				bar	(psi)	bar	(psi)		
6.3	1/4	420	(6,090)	420	(6,090)	420	(6,090)	1,260	(18,270)	1,260	(18,270)	1,260	(18,270)	12	(3.2)	.006	160	(36)
10.0	3/8	350	(5,075)	350	(5,075)	350	(5,075)	1,000	(14,500)	1,000	(14,500)	1,000	(14,500)	23	(6.1)	.012	160	(36)
12.5	1/2	330	(4,785)	330	(4,785)	330	(4,785)	1,000	(14,500)	1,000	(14,500)	1,000	(14,500)	45	(11.9)	.020	200	(45)
16.0	5/8	330	(4,785)	330	(4,785)	330	(4,785)	1,000	(14,500)	1,000	(14,500)	1,000	(14,500)	74	(19.5)	.026	200	(45)
19.0	3/4	330	(4,785)	330	(4,785)	330	(4,785)	1,000	(14,500)	1,000	(14,500)	1,000	(14,500)	100	(26.4)	.032	200	(45)
25.0	1	300	(4,350)	300	(4,350)	300	(4,350)	800	(11,600)	800	(11,600)	800	(11,600)	189	(50.0)	.035	280	(63)
27.0	1 1/4	300	(4,350)	300	(4,350)	300	(4,350)	800	(11,600)	800	(11,600)	800	(11,600)	225	(59.6)	.017	490	(110)
31.5	1 1/2	270	(3,915)	270	(3,915)	270	(3,915)	800	(11,600)	800	(11,600)	700	(10,150)	288	(76.3)	.050	580	(131)



Applications

- Hydraulic fluid transfer
- Agriculture equipment
- High impulse hydraulics
- Construction equipment and implements

Flow Data

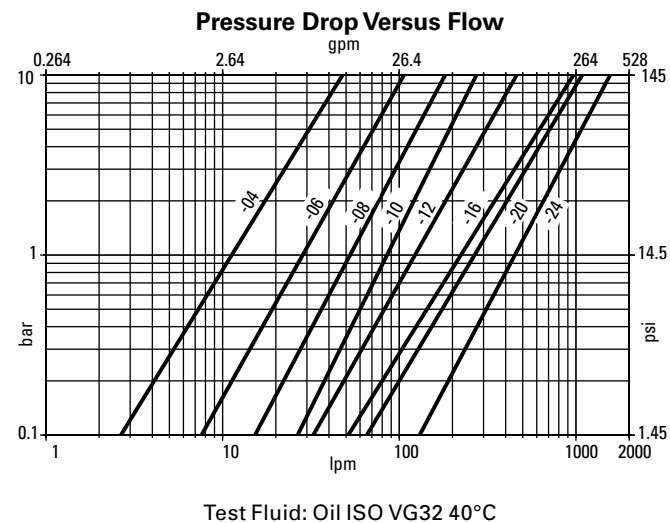

FD99 Series

High Pressure Flush Face
ISO 16028 Interchange

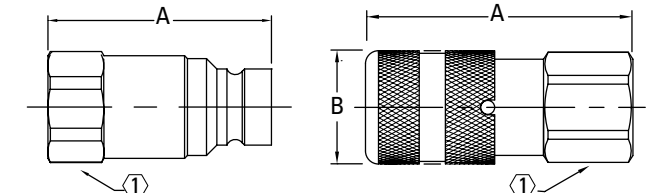
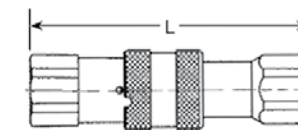

Figure 1

Figure 2

Dimensions (NPT)

Part Number	Coupling Type	Body Size	Port Size	Thread	Type	Fig.	Dimensions			Hex ①		
							A mm	A (in)	B mm	B (in)	mm	(in)
FD99-1001-04-04	Female	1/4	1/4	1/4-18	Female NPT	2	56,1	(2.21)	23,8	(1.10)	27	(1.06)
FD99-1002-04-04	Male	1/4	1/4	1/4-18	Female NPT	1	50,9	(1.89)			22	(.87)
FD99-1001-06-06	Female	3/8	3/8	3/8-18	Female NPT	2	64,8	(2.55)	32,0	(1.26)	30	(1.18)
FD99-1002-06-06	Male	3/8	3/8	3/8-18	Female NPT	1	60,0	(2.36)			27	(1.06)
FD99-1001-08-06	Female	3/8	1/2	1/2-14	Female NPT	2	69,8	(2.75)	32,0	(1.26)	30	(1.18)
FD99-1002-08-06	Male	3/8	1/2	1/2-14	Female NPT	1	62,5	(2.46)			27	(1.06)
FD99-1001-08-08	Female	1/2	1/2	1/2-14	Female NPT	2	76,8	(3.02)	38,0	(1.50)	36	(1.47)
FD99-1002-08-08	Male	1/2	1/2	1/2-14	Female NPT	1	68,0	(2.68)			36	(1.47)
FD99-1001-12-08	Female	1/2	3/4	3/4-14	Female NPT	2	83,8	(3.30)	38,0	(1.50)	36	(1.42)
FD99-1002-12-08	Male	1/2	3/4	3/4-14	Female NPT	1	70,5	(2.78)			36	(1.42)
FD99-1001-12-10	Female	5/8	3/4	3/4-14	Female NPT	2	84,0	(3.31)	42,0	(1.65)	41	(1.61)
FD99-1002-12-10	Male	5/8	3/4	3/4-14	Female NPT	1	73,0	(2.87)			36	(1.42)
FD99-1001-12-12	Female	3/4	3/4	3/4-14	Female NPT	2	95,8	(3.77)	48,0	(1.89)	46	(1.81)
FD99-1002-12-12	Male	3/4	3/4	3/4-14	Female NPT	1	83,7	(3.30)			46	(1.81)
FD99-1001-16-12	Female	3/4	1	1-11 1/2	Female NPT	2	98,8	(3.89)	48,0	(1.89)	46	(1.81)
FD99-1002-16-12	Male	3/4	1	1-11 1/2	Female NPT	1	83,7	(3.30)			46	(1.81)
FD99-1001-16-16	Female	1	1	1-11 1/2	Female NPT	2	104,8	(4.13)	55,0	(2.17)	55	(2.17)
FD99-1002-16-16	Male	1	1	1-11 1/2	Female NPT	1	96,8	(3.84)			55	(2.17)
FD99-1001-20-16	Female	1	1 1/4	1 1/4-11 1/2	Female NPT	2	105,8	(4.17)	55,0	(2.17)	55	(2.17)
FD99-1002-20-16	Male	1	1 1/4	1 1/4-11 1/2	Female NPT	1	90,0	(3.54)			55	(2.17)
FD99-1001-20-20	Female	1 1/4	1 1/4	1 1/4-11 1/2	Female NPT	2	125,1	(4.93)	65,0	(2.56)	55	(2.17)
FD99-1002-20-20	Male	1 1/4	1 1/4	1 1/4-11 1/2	Female NPT	1	105,0	(4.13)			55	(2.17)
FD99-1001-24-24	Female	1 1/2	1 1/2	1 1/2-11 1/2	Female NPT	2	132,4	(5.21)	80,0	(3.15)	65	(2.56)
FD99-1002-24-24	Male	1 1/2	1 1/2	1 1/2-11 1/2	Female NPT	1	111,1	(4.37)			65	(2.56)



Dust Caps and Dust Plugs

Body Size	Part Number	Coupling Type	Cap Material
1/4 - 1/4	FD89-1009-04	Female	PVC
3/8 - 3/8	FD89-1009-06-06	Female	PVC
1/2 - 3/8	FD89-1009-08-06	Female	PVC
1/2 - 1/2	FD89-1009-08-08	Female	PVC
3/4 - 1/2	FD89-1009-12-08	Female	PVC
3/4	FD89-1009-12	Female	PVC
1	FD89-1009-16	Female	PVC
1 1/4	FD89-1009-20	Female	PVC
1 1/2	FD89-1009-24	Female	Aluminum

Body Size	Part Number	Coupling Type	Cap Material
1/4 - 1/4	FD89-1008-04	Male	PVC
3/8 - 3/8	FD89-1008-06-06	Male	PVC
1/2 - 3/8	FD89-1008-08-06	Male	PVC
1/2 - 1/2	FD89-1008-08-08	Male	PVC
3/4 - 1/2	FD89-1008-12-08	Male	PVC
3/4	FD89-1008-12	Male	PVC
1	FD89-1008-16	Male	PVC
1 1/4	FD89-1008-20	Male	PVC
1 1/2	FD89-1008-24	Male	Aluminum

Connected Length

Body Size	Port Size	Connected Length "L"	
		mm	(in)
1/4	1/4	90,2	(3.55)
3/8	3/8	109,0	(4.29)
3/8	1/2	116,2	(4.58)
1/2	1/2	127,5	(5.02)
1/2	3/4	137,0	(5.39)
3/4	3/4	160,5	(6.32)
5/8	3/4	139,4	(5.49)
3/4	1	160,5	(6.32)
1	1 1/4	173,0	(6.81)
1 1/4	1 1/4	206,9	(8.15)
1 1/2	1 1/2	215,0	(8.46)

FD99 Series

High Pressure Flush Face
ISO 16028 Interchange

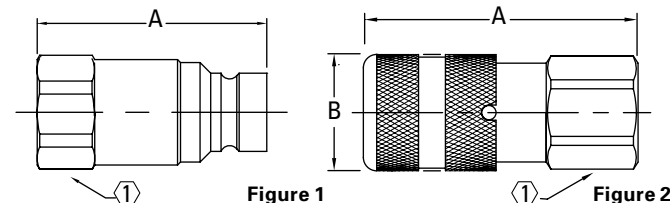

Dimensions (NPT)

Part Number	Coupling Type	Body Size	Port Size	Thread	Type	Fig.	Dimensions A		B		Hex ①	
							mm	(in)	mm	(in)	mm	(in)
FD99-1004-06-04	Female	1/4	3/8	9/16-18 UNF	SAE O-ring	2	53,1	(2.09)	28,0	(1.10)	27	(1.06)
FD99-1005-06-04	Male	1/4	3/8	9/16-18 UNF	SAE O-ring	1	47,9	(1.89)			22	(.87)
FD99-1004-06-06	Female	3/8	3/8	9/16-18 UNF	SAE O-ring	2	64,8	(2.55)	32,0	(1.26)	30	(1.18)
FD99-1005-06-06	Male	3/8	3/8	9/16-18 UNF	SAE O-ring	1	60,0	(2.36)			27	(1.06)
FD99-1004-08-06	Female	3/8	1/2	3/4-16 UNF	SAE O-ring	2	69,8	(2.75)	32,0	(1.26)	30	(1.18)
FD99-1005-08-06	Male	3/8	1/2	3/4-16 UNF	SAE O-ring	1	62,5	(2.46)			27	(1.06)
FD99-1004-08-08	Female	1/2	1/2	3/4-16 UNF	SAE O-ring	2	76,8	(3.02)	38,0	(1.50)	36	(1.42)
FD99-1005-08-08	Male	1/2	1/2	3/4-16 UNF	SAE O-ring	1	68,0	(2.68)			36	(1.18)
FD99-1004-10-06	Female	3/8	5/8	7/8-14 UNF	SAE O-ring	2	71,8	(2.83)	32,0	(1.26)	30	(1.18)
FD99-1005-10-06	Male	3/8	5/8	7/8-14 UNF	SAE O-ring	1	65,5	(2.58)			30	(1.18)
FD99-1004-10-08	Female	1/2	5/8	7/8-14 UNF	SAE O-ring	2	78,8	(3.10)	38,0	(1.50)	36	(1.42)
FD99-1005-10-08	Male	1/2	5/8	7/8-14 UNF	SAE O-ring	1	70,0	(2.76)			36	(1.42)
FD99-1004-12-08	Female	1/2	3/4	1 1/16-12 UN	SAE O-ring	2	83,8	(3.30)	38,0	(1.50)	36	(1.42)
FD99-1005-12-08	Male	1/2	3/4	1 1/16-12 UN	SAE O-ring	1	72,5	(2.85)			36	(1.42)
FD99-1004-12-10	Female	5/8	3/4	1 1/16-12 UN	SAE O-ring	2	84,0	(3.31)	42,0	(1.65)	41	(1.61)
FD99-1005-12-10	Male	5/8	3/4	1 1/16-12 UN	SAE O-ring	1	73,0	(2.87)			37	(1.42)
FD99-1004-12-12	Female	3/4	3/4	1 1/16-12 UN	SAE O-ring	2	98,8	(3.89)	48,0	(2.89)	46	(1.81)
FD99-1005-12-12	Male	3/4	3/4	1 1/16-12 UN	SAE O-ring	1	83,7	(3.30)			46	(1.81)
FD99-1004-16-12	Female	3/4	1	1 5/16-12 UN	SAE O-ring	2	98,8	(3.89)	48,0	(1.89)	46	(1.81)
FD99-1005-16-12	Male	3/4	1	1 5/16-12 UN	SAE O-ring	1	83,7	(3.03)			46	(1.81)
FD99-1004-16-16	Female	1	1	1 5/16-12 UN	SAE O-ring	2	104,8	(4.13)	55,0	(2.17)	55	(2.17)
FD99-1005-16-16	Male	1	1	1 5/16-12 UN	SAE O-ring	1	96,8	(3.81)			55	(2.17)
FD99-1004-20-16	Female	1	1 1/4	1 5/8-12 UN	SAE O-ring	2	105,8	(4.17)	55,0	(2.17)	55	(2.17)
FD99-1005-20-16	Male	1	1 1/4	1 5/8-12 UN	SAE O-ring	1	90,0	(3.54)			55	(2.17)
FD99-1004-20-20	Female	1 1/4	1 1/4	1 5/8-12 UN	SAE O-ring	2	125,1	(4.93)	65,0	(2.56)	55	(2.17)
FD99-1005-20-20	Male	1 1/4	1 1/4	1 5/8-12 UN	SAE O-ring	1	105,0	(4.13)			55	(2.17)
FD99-1004-24-24	Female	1 1/2	1 1/2	1 7/8-12 UN	SAE O-ring	2	132,4	(5.21)	80,0	(3.15)	65	(2.56)
FD99-1005-24-25	Male	1 1/2	1 1/2	1 7/8-12 UN	SAE O-ring	1	111,1	(4.37)			65	(2.56)

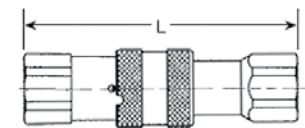

Connected Length

Body Size	Port Size	Connected Length "L"	
		mm	(in)
1/4	1/4	96,2	(3.79)
3/8	3/8	109,0	(4.29)
3/8	1/2	116,5	(4.59)
3/8	5/8	121,3	(4.78)
1/2	1/2	127,5	(5.02)
1/2	3/4	139,0	(5.47)
1/2	5/8	131,5	(5.18)
3/4	3/4	166,5	(6.32)
5/8	3/4	139,5	(5.49)
3/4	1	161,0	(6.34)
1	1	178,6	(7.03)
1	1 1/4	173,0	(6.81)
1 1/4	1 1/4	206,9	(8.15)
1 1/2	1 1/2	215,0	(8.46)

Dust Caps and Dust Plugs

Body Size	Part Number	Coupling Type	Cap Material
3/8 - 1/4	FD89-1009-04	Female	PVC
3/8 - 3/8	FD89-1009-06-06	Female	PVC
1/2 - 3/8	FD89-1009-08-06	Female	PVC
3/8 - 1/2	FD89-1009-08-08	Female	PVC
3/4 - 1/2	FD89-1009-12-08	Female	PVC
3/4	FD89-1009-12	Female	PVC
1	FD89-1009-16	Female	PVC
1 1/4	FD89-1009-20	Female	PVC
1 1/2	FD89-1009-24	Female	Aluminum

Body Size	Part Number	Coupling Type	Cap Material
3/8 - 1/4	FD89-1008-04	Male	PVC
3/8 - 3/8	FD89-1008-06-06	Male	PVC
1/2 - 3/8	FD89-1008-08-06	Male	PVC
1/2 - 1/2	FD89-1008-08-08	Male	PVC
3/4 - 1/2	FD89-1008-12-08	Male	PVC
3/4	FD89-1008-12	Male	PVC
1	FD89-1008-16	Male	PVC
1 1/4	FD89-1008-20	Male	PVC
1 1/2	FD89-1008-24	Male	Aluminum

FD72 Series

Connect Under Pressure - Farm
ISO 5675 Interchange



The FD72 Series coupling incorporates special valving allowing connection to a FD76 Series male half under pressure. The maximum operating pressure is 3,000 psi. Contains an over travel, self-sealing poppet valve construction for connecting to a pressurized male tip. Applications require that the tractor control valve be actuated to open the flow path and to equalize the pressure.

Product Features

- Push-to-connect for one-hand operation when sleeve is mounted
- Interchanges with ISO 5675 male tips
- Retaining ring groove on female half for bulkhead and breakaway frame mounting
- Standard seal material – Buna-N
- Standard body material – High resistance carbon steel with zinc trivalent plating

Applications

- Hydraulic fluid transfer
- Agricultural equipment

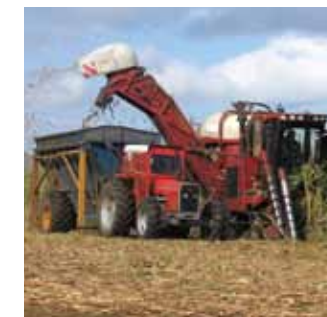

Physical Characteristics

Body Size	Max. Operating Pressure		Min. Burst Pressure Connected		Vacuum Conncted Only	Rated Flow		Air Inclusion	Fluid Loss
	bar	(psi)	bar	(psi)	(in./Hg)	L/min	(gpm)	cc. max.	cc.max.
5/8	207	(3,000)	827	(12,000)	28	61	(16)	2.8	2.8

Dimensions (Female NPT, Valved)

Part Number	Coupling Type	Body Size	Port Size	Thread	Type	Fig.	Dimensions					Hex ①						
							A	B	C	D	E							
FD76-1002-08-10	Male	5/8	1/2	1/2-14	Female Pipe	1	52.1	(2.05)	-	-	-	-	-	-	26.9	(1.06)		
FD72-1001-08-10	Female	5/8	1/2	1/2-14	Female Pipe	2	80.5	(3.17)	38.6	(1.52)	38.1	(1.50)	35.8	(1.41)	5.1	(.20)	25.4	(1.00)

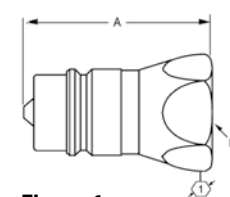

Figure 1

Dust Cap

Part Number	Body Size
5657-10	5/8

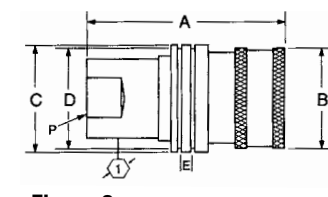

Figure 2

Dust Plug

Part Number	Body Size
5659-10	5/8



Break Away Frame

Part Number	Body Size
5603	5/8



Flow Data

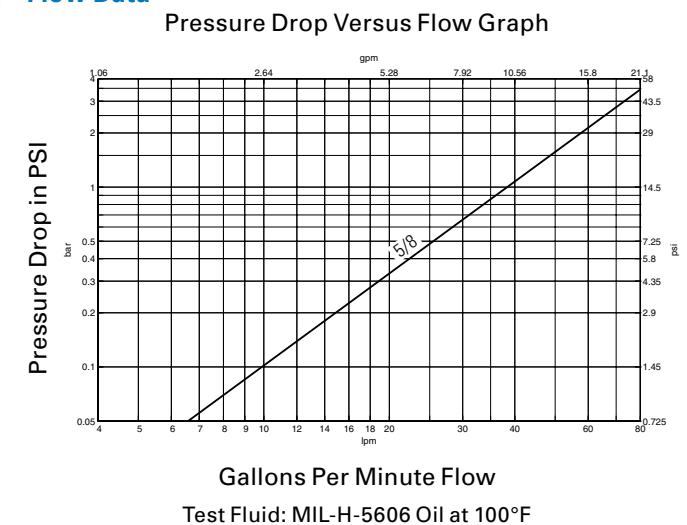

FD70 & FD76 Series

Male Tip – Farm
ISO 5675 Interchange



FD70 Deere



FD76 ISO

Designed to connect with female couplings on most older style John Deere farm equipment. The FD70 and FD76 Series quick disconnect couplings interchange with ISO 5675 quick disconnect couplings used on older farm tractors found throughout North America and abroad.



Product Features

- Optional ball or poppet style valving

Applications

- Hydraulic fluid transfer – Agricultural equipment

Dimensions

Part Number Buna-N	Coupling Type	Body Size	Port Size	Thread	Type	Fig.	Dimensions A		Hex ①	
							mm	(in)	mm	(in)
FD70-1010-08-10	Male	5/8	1/2	3/4-16	Female SAE O-ring		49.8	(1.96)	25,4	(1.00)
FD76-1002-08-10	Male	5/8	1/2	1/2-14	Female NPT		52.1	(2.05)	26,9	(1.06)
FD76-1010-08-10	Male	5/8	1/2	3/4-16	Female SAE O-ring		52.1	(2.05)	25,4	(1.00)

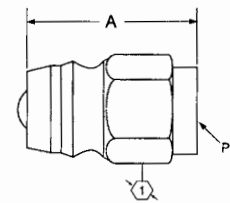

Figure 1

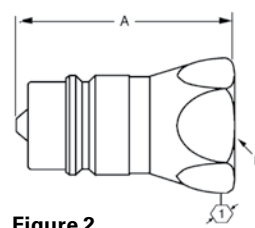

Figure 2

FD15 Series

Oil Sampling Valve



FD15 Series Oil Sampling Valve is designed for in-line sampling of system fluids without system shutdown, usually in less than one minute, and without fluid contamination.

Product Features

- Standard seal material – Buna
- Corrosion resistant plated steel with brass internal components
- Operating Temperature Range: -65°F to +275°F (-53°C to +135°C)
- Minimum Burst Pressure: 1200 psi
- Minimum Particle Restriction: 500 microns
- Maximum Torque to Operate: 10 in. lbs.

- FD15-1000-04 is qualified to the MIL-V-81940/2-1

Note: This valve is not intended for aerospace applications.

Applications

- Engine oil
- Lubricating oil
- Transmission fluid and hydraulic fluids in mobile construction equipment, military vehicles, trucks and stationary equipment



Operation

- For best results, Eaton FD15 Oil Sampling Valves should be installed in dynamic fluid lines in low pressure and return lines. If only one sampling point can be chosen, it should be in the return line, upstream of any return line filter. This will insure a representative sample of all components in the fluid system for their present condition.

Instructions

1. Remove metal dustcover on discharge port.
2. Discharge approximately 200 ml of oil to flush valve by turning knurled knob 1/4 turn to the right. Dispose of this sample in the appropriate manner.
3. Locate clean oil sample bottle under discharge port. (Sample bottles are usually supplied by the oil analysis lab.)
4. Turn knurled knob 1/4 turn to the right until bottle is filled to the desired level. The knob can be backed off to throttle the rate of flow.
5. When bottle is filled let go of the knurled knob, the valve will close automatically. Replace metal dustcover wrench tight.

As required in MIL-V-81940/2-1 this valve's flow rate is between 100 and 1500 milliliters per minute at pressures from 0-50 psi. (MIL-V-81940/2-1 applies only to pressures from 50-300 psi.)

*The 1/4" NPTF version is qualified to MIL-V-81940/2-1 and its performance is representative of the other inlet port configurations listed above. QPL-81940-9 6-5-89

FD15 Series

Oil Sampling Valve

Male Pipe Thread 50-300 psi

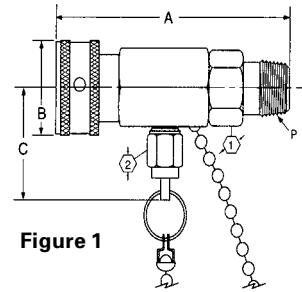

Figure 1

Male SAE O-ring Thread 50-300 psi

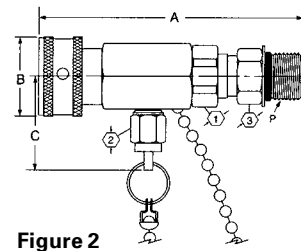

Figure 2

Dimensions (Male Pipe Thread)

Part Number Buna-N	Sampling Type	Port Size	Thread Type	Fig.	Dimensions			Hex ①	Hex ②	Hex ③		
					A	B	C					
					mm (in)	mm (in)	mm (in)	mm (in)	mm (in)	mm (in)		
FD15-1000-02	50-300 psi	1/8	1/8-27	Male Pipe Thread	1	61.5 (2.42)	25.4 (1.00)	33.0 (1.30)	17.5 (.69)	9.7 (.38)	-	-
FD15-1000-04	50-300 psi	1/4	1/4-18	Male Pipe Thread	1	65.0 (2.56)	25.4 (1.00)	33.0 (1.30)	17.5 (.69)	9.7 (.38)	-	-

Dimensions (Male SAE O-ring Thread)

Part Number Buna-N	Sampling Type	Port Size	Thread Type	Fig.	Dimensions			Hex ①	Hex ②	Hex ③	
					A	B	C				
					mm (in)	mm (in)	mm (in)	mm (in)	mm (in)	mm (in)	
FD15-1002-04	50-300 psi	7/16	7/16-20	Male SAE O-Ring Thread	2	70.9 (2.79)	25.4 (1.00)	33.0 (1.30)	17.5 (.69)	9.7 (.38)	14.2 (.56)

Dimensions (Male Pipe Thread)

Part Number Buna-N	Sampling Type	Port Size	Thread Type	Fig.	Dimensions			Hex ①	Hex ②	Hex ③		
					A	B	C					
					mm (in)	mm (in)	mm (in)	mm (in)	mm (in)	mm (in)		
FD15-1026-04	0-50 psi	1/4	1/4-18	Male Pipe Thread	3	65.0 (2.56)	25.4 (1.00)	33.0 (1.30)	17.5 (.69)	9.7 (.38)	-	-

Dimensions Male SAE O-ring Thread)

Part Number Buna-N	Sampling Type	Port Size	Thread Type	Fig.	Dimensions			Hex ①	Hex ②	Hex ③	
					A	B	C				
					mm (in)	mm (in)	mm (in)	mm (in)	mm (in)	mm (in)	
FD15-1025-04	0-50 psi	7/16	7/16-20	Male SAE O-Ring Thread	4	70.9 (2.79)	25.4 (1.00)	33.0 (1.30)	17.5 (.69)	9.7 (.38)	14.2 (.56)

Male Pipe Thread 0-50 psi

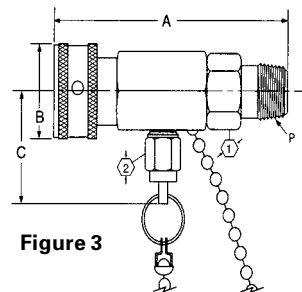

Figure 3

Male SAE O-ring Thread 0-50 psi

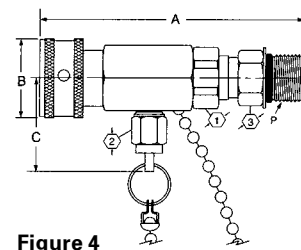

Figure 4

FD90 Series

Diagnostic Coupling
SAE J1502 Interchange



The FD90 Series diagnostic coupling is designed to connect and disconnect pressure gauges to hydraulic systems, eliminating the need for permanent gauges. The maximum operating pressure is 7,000 psi.

Product Features

- Automatic sleeve for one hand push-to-connect operation
- Flush face valving provides minimal fluid loss and low air inclusion
- Self-sealing valve design allows connection and disconnection at 500 psi
- Broad range of end configurations for system accessibility
- Standard seal material – Buna-N
- Standard seal material – High resistance carbon steel with zinc trivalent plating

Applications

- Diagnostic pressure testing for hydraulic systems



Physical Characteristics

Coupling Size	Max. Operating Pressure		Min. Burst Pressure Connected		Vacuum Connected Only (in./Hg)	Rated Flow L/min (gpm)	Air Inclusion cc. max.	Fluid Loss cc. max.
	bar	(psi)	bar	(psi)				
1/4	483	(7,000)	1,931	(28,000)	28	xx (0.5)	0.02	0.10

Dimensions (Female Pipe, Valved)

Part Number Buna-N	Part Number with Dust Cap Buna-N	Coupling Type	Coupling Size	Body Size	Port Size	Thread Type	Fig.	Dimensions			
								A	B	Hex ①	
								mm (in)	mm (in)	mm (in)	
FD90-1034-02-04	FD90-1035-02-04	Male	-04	1/4	1/8	1/8 - 27	Female NPT	1	43.2 (1.70)	-	15.7 (0.62)
FD90-1021-02-04	-	Female	-04	1/4	1/8	1/8 - 27	Female NPT	2	49.5 (1.95)	25.40 (1.00)	19 (0.75)
FD90-1034-04-04	FD90-1035-04-04	Male	-04	1/4	1/4	1/4 - 18	Female NPT	1	48.3 (1.90)	-	19.1 (0.75)
FD90-1021-04-04	-	Female	-04	1/4	1/4	1/4 - 18	Female NPT	2	57.2 (2.25)	25.4 (1.00)	19.1 (0.75)

Dimensions (Male SAE O-ring, Valved)

Part Number Buna-N	Part Number with Dust Cap Buna-N	Coupling Type	Coupling Size	Body Size	Port Size	Thread Type	Fig.	Dimensions			
								A	B	Hex ①	
								mm (in)	mm (in)	mm (in)	
FD90-1044-03-04	FD90-1004-03-04	Male	-04	1/4	3/8	3/8 - 24	Male SAE O-Ring	3	38.6 (1.52)	-	15.7 (0.62)
FD90-1044-04-04	FD90-1004-04-04	Male	-04	1/4	7/16	7/16 - 20	Male SAE O-Ring	3	40.1 (1.58)	-	15.7 (0.62)
FD90-1044-05-04	FD90-1004-05-04	Male	-04	1/4	1/2	1/2 - 20	Male SAE O-Ring	3	33.5 (1.32)	-	15.7 (0.62)
FD90-1044-06-04	FD90-1004-06-04	Male	-04	1/4	9/16	9/16 - 18	Male SAE O-Ring	3	33.5 (1.32)	-	17.5 (0.69)

Dimensions (Male Pipe, Valved)

Part Number Buna-N	Part Number with Dust Cap Buna-N	Coupling Type	Coupling Size	Body Size	Port Size	Thread Type	Fig.	Dimensions			
								A	B	Hex ①	
								mm (in)	mm (in)	mm (in)	
FD90-1012-02-04	FD90-1045-02-04	Male	-04	1/4	1/8	1/8 - 27	Male NPT	4	40.6 (1.60)	-	15.7 (0.62)
FD90-1012-04-04	FD90-1045-04-04	Male	-04	1/4	1/4	1/4 - 18	Male NPT	4	37.8 (1.49)	-	17.5 (0.69)

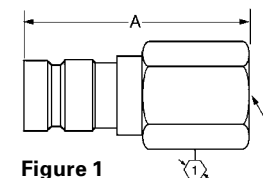

Figure 1

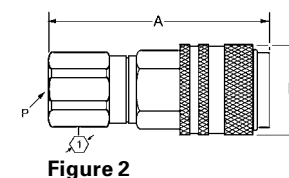

Figure 2

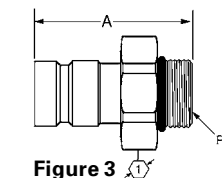

Figure 3

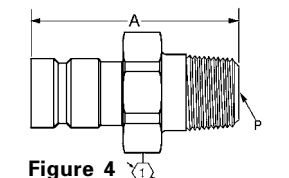

Figure 4

FD90 Series

Diagnostic Coupling
SAE J1502 Interchange

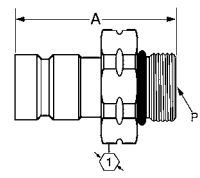

Figure 5

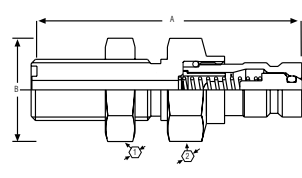

Figure 6

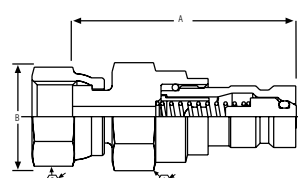

Figure 7

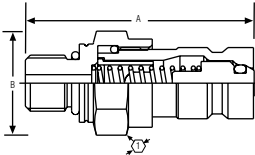

Figure 8

Dimensions (Metric Male O-ring, Valved)

Part Number Buna-N	Part Number with Dust Cap Buna-N	Coupling Type	Coupling Size	Body Size	Port Size	Thread	Type	Fig.	Dimensions				Hex ①	
									A	B				
									mm	(in)	mm	(in)	mm	(in)
FD90-1046-06-04	FD90-1047-06-04	Male	-04	1/4	M14	M14x1.5	Male O-ring	5	38.5	(1.52)	-	-	19.1	(0.75)

Dimensions (Female SAE O-ring, Valved)

Part Number Buna-N	Coupling Type	Coupling Size	Body Size	Port Size	Thread	Type	Fig.	Dimensions				Hex ①		
								A	B					
									mm	(in)	mm	(in)	mm	(in)
FD90-1041-09-04	Female	-04	1/4	7/16	7/16 - 20	Female SAE O-ring	2	55.9	(2.20)	25.40	(1.00)	19.1	(0.75)	

Dimensions (Male ORS Bulkhead, Valved)

Part Number Buna-N	Coupling Type	Coupling Size	Body Size	Port Size	Thread	Type	Fig.	Dimensions				Hex ①		
								A	B					
									mm	(in)	mm	(in)	mm	(in)
FD90-1206-04-04	Male	-04	1/4	9/16	9/16 - 18	Male ORS Bulkhead	6	62.5	(2.46)	20.6	(0.81)	20.6	(0.81)	

Dimensions (Male ORS Bulkhead, Valved)

Part Number Buna-N	Coupling Type	Coupling Size	Body Size	Port Size	Thread	Type	Fig.	Dimensions				Hex ①		
								A	B					
									mm	(in)	mm	(in)	mm	(in)
FD90-1061-04-04	Male	-04	1/4	9/16	9/16 - 18	Female ORS Swivel	7	46.5	(1.79)	22.1	(0.87)	17.5	(0.69)	
FD90-1061-06-04	Male	-04	1/4	11/16	11/16 - 16	Female ORS Swivel	7	46.5	(1.83)	23.9	(0.94)	20.6	(0.81)	
FD90-1061-08-04	Male	-04	1/4	13/16	13/16 - 16	Female ORS Swivel	7	49.0	(1.93)	27.4	(1.08)	23.9	(0.94)	

Dimensions (Male Metric O-ring, Valved)

Part Number Buna-N	Coupling Type	Coupling Size	Body Size	Port Size	Thread	Type	Fig.	Dimensions				Hex ①		
								A	B					
									mm	(in)	mm	(in)	mm	(in)
FD90-1090-10-04	Male	-04	1/4	M10	M10x1	Mertic O-ring	8	40.1	(1.58)	18.3	(0.72)	-	-	

Dust Cap for Male Halves

Coupling Size	Part Number
-04	FD90-1040-04-04



Dust Cap for
Male Halves

Pressure Gauge Kit

FF14802



The Eaton pressure gauge kit and screw together test couplings provide accurate and efficient pressure control and monitoring of your hydraulic system, while minimizing the introduction of contamination. The complete kit is pre-packaged with Eaton's most common adapters and test couplings.

Product Features

- Test system at working pressure
- 345 bar (5,000 psi) connect under pressure
- 630 bar (9,000 psi) working pressure
- 345 bar (5,000 psi) connect under pressure
- Accurate pressure control and system monitoring

Couplings/Adapters

- Standard body material – Zinc Nickel Plated Steel
- Standard seal material – Viton
- 345 bar (5,000 psi) connect under pressure
- 630 bar (9,000 psi) working pressure

Hose Assemblies

- 630 bar (9,000 psi) working pressure
- 20mm (.75") bend radius
- Nominal Bore 2mm (.08")
- Hose cover/core – PA 11/12
- Reinforcement – synthetic fiber

Gauges

- Polished Brass Casing
- Glycerine Filled
- Dual Scales
- Relief Valve
- Acrylic Lens

Applications

- Hydraulics and mineral based fluids
- Agricultural equipment
- Construction equipment
- On-Highway vehicles
- Industrial equipment

Pressure Gauge Kit

Complete Kit Number	Component Part Number	Description	Quantity Per Kit
FF14802	FF14783	1/8" NPT Test Coupling	2
	FF14784	1/4" NPT Test Coupling	2
	FF14787	7/16-20 UNF Test Coupling	1
	FF14788	9/16-20 UNF Test Coupling	1
	FF14794	1/4" NPT Gauge Adapter	3

Complete Kit Number	Component Part Number	Description	Quantity Per Kit
	FF14796	Union Adapter	2
	FF14798	60" Test Hose Assembly	2
	FF14799	(-) 30 in/Hg - 30 psi Gauge	1
	FF14800	1,000 psi Gauge	1
	FF14801	7,500 psi Gauge	1

Dimensions (Standard Test Couplings)

Part Number	Thread	Dimensions		Hex ①	Bag Quantity*		
		A	B				
		mm	(in)	mm	(in)	mm	(in)
FF14783	1/8" NPT	45,0	(1.77)	20,0	(.79)	17,0	(.67)
FF14784	1/4" NPT	50,0	(1.97)	20,0	(.79)	17,0	(.67)
FF14785	M14	49,0	(1.93)	20,0	(.79)	19,0	(.75)
FF14786	M16	48,5	(1.91)	20,0	(.79)	22,0	(.87)
FF14787	7/16-20 UNF	47,0	(1.85)	20,0	(.79)	17,0	(.67)
FF14788	9/16-20 UNF	47,5	(1.87)	20,0	(.79)	19,0	(.75)

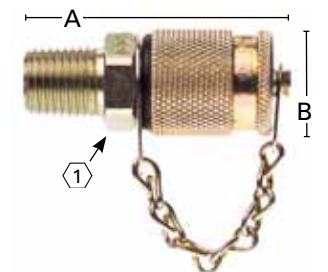

Standard Test Couplings

*When the indicated part number is ordered, the bag quantity is the number of pieces supplied. For example, if a quantity of one FF14792 is ordered, one bag containing two pieces will be delivered.

Dimensions (Bulkhead Couplings)

Part Number	Thread	Dimensions A		Dimensions B		Hex ①		Hex ②		Bag Quantity*
		mm	(in)	mm	(in)	mm	(in)	mm	(in)	
FF14789	M16	72,0	2.83	20,0	.79	17,0	.67	19,0	.75	2

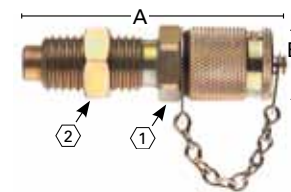

Bulkhead Couplings

Dimensions (Swivel Run Tee with Test Coupling)

Part Number	Thread #1	Thread #2	Dimensions A		Dimensions B		Hex ①		Bag Quantity*
			mm	(in)	mm	(in)	mm	(in)	
FF14790	7/16-20 UNF	7/16-20 UNF	47,7	(1.88)	20,0	(.79)	27,0	(1.06)	2
FF14791	9/16-18 UNF	9/16-18 UNF	47,7	(1.88)	20,0	(.79)	27,0	(1.06)	2
FF14792	3/4-16 UNF	3/4-16 UNF	47,7	(1.88)	20,0	(.79)	27,0	(1.06)	2

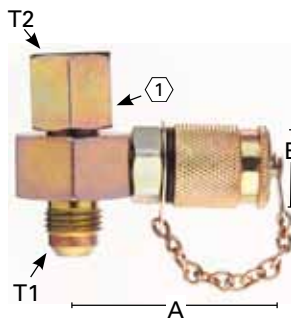

Swivel Run Tee with Test Coupling

Dimensions (Gauge Adapter)

Part Number	Thread #1	Thread #2	Dimensions A		Hex ①		Hex ②		Bag Quantity*
			mm	(in)	mm	(in)	mm	(in)	
FF14793	1/4" NPT	M16	54,0	(2.13)	19,0	(.75)	19,0	(.75)	2

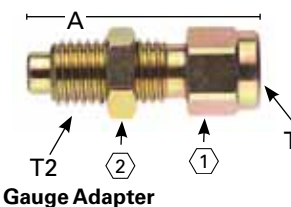

Gauge Adapter

Dimensions (Direct Gauge Adapter)

Part Number	Thread	Dimensions A		Dimensions B		Hex ①		Bag Quantity*
		mm	(in)	mm	(in)	mm	(in)	
FF14794	1/4" NPT	40,5	(1.59)	20,0	(.79)	19,0	(.75)	2
FF14795	7/16-20 UNF	41,0	(1.61)	20,0	(.79)	19,0	(.75)	2

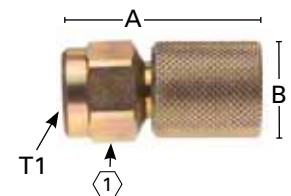

Direct Gauge Adapter

Dimensions (Union Adapter)

Part Number	Thread #1	Thread #2	Dimensions A		Hex ①		Bag Quantity*
			mm	(in)	mm	(in)	
FF14796	M16	M16	42,5	(1.67)	17,0	(.67)	2

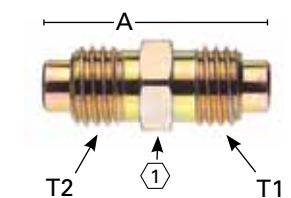

Union Adapter

Dimensions (Test Hose Assembly)

Part Number	Thread	Dimensions				Bag Quantity*
		Cut Length		Overall Length		
		mm	(in)	mm	(in)	
FF14797	M16	872,0	(34.33)	914,4	(36.00)	1
FF14798	M16	1482,0	(58.35)	1524,0	(60.00)	1



Test Hose Assembly

Dimensions (Gauges)

Part Number	Thread	Dimensions A		Dimensions B		Rating	Bag Quantity*
		mm	(in)	mm	(in)		
FF14799	1/4" NPT	65,3	(2.57)	53,3	(2.10)	(-)30 in/Hg - 30 psi	1
FF14800	1/4" NPT	65,3	(2.57)	53,3	(2.10)	0 - 1,000 psi	1
FF14801	1/4" NPT	65,3	(2.57)	53,3	(2.10)	0 - 7,500 psi	1

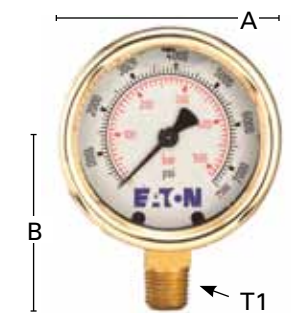

Gauges

*When the indicated part number is ordered, the bag quantity is the number of pieces supplied. For example, if a quantity of one FF14792 is ordered, one bag containing two pieces will be delivered.

FD14 Series

Oil Drain Coupling



The FD14 Drain coupling is designed to serve as a drain port for use with Eaton's FLOCS (Fast Lube Oil Change System) as well as providing a purging port for use during pre-fill operations. The FD14 provides a leak free push to connect operation for improving speed and efficiency for oil evacuation systems.

Product Features

- Low-Profile design with multiple sealing mechanisms
- Broad range of standard thread styles for Male Half
- Standard male half seal material - Viton
- Standard body material - High resistance carbon steel with zinc trivalent chromate plating with zinc die-cast valve
- Push-To-Connect female half for easy one-hand operation
- Utilizes a Copper-Crush gasket to seat against the port face
- Standard female half seal material - Buna-N

Physical Characteristics

Body Size	Max. Operating Pressure		Min. Burst Pressure Connected		Vacuum Connected Only	Rated Flow	
	bar	(psi)	bar	(psi)	(in./Hg)	L/min	(gpm)
3/8	3.5	(50)	7.0	(200)	28	12	(3)



Applications

- Automated oil evacuation systems
- Gravity drain oil evacuation systems

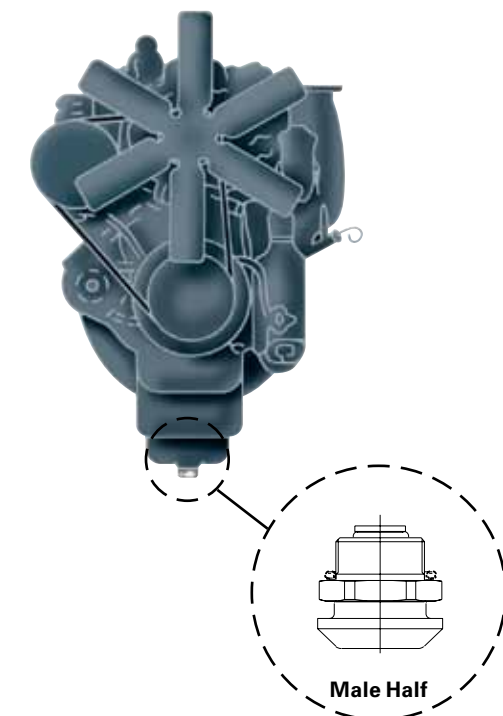

FD14 Series

Oil Drain Coupling

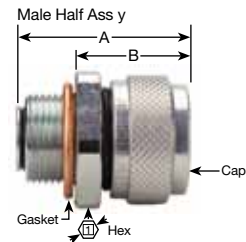

Figure 1

Dimensions (English Thread)

Body Size	Thread Size	Fig.	Dimensions		Hex		Min. Assy. Torque	Part Number Assembly (includes Gasket & Cap)	Gasket (Copper-Crush)	Cap (Brass)			
			A	B	(in)	(in)					N-m	(lbs-ft)	
3/8	1 1/16-12 UN-2A	1	39.1	(1.54)	24.4	(.96)	38.1	(1 1/2)	41-81	(30-60)*	FD14-4002-20-06	FD14-1206-08	FD14-1210-06
3/8	1 1/4-18 UNEF-2A	1	39.1	(1.54)	24.4	(.96)	38.1	(1 1/2)	41-81	(30-60)*	FD14-4002-05-06	FD14-1206-11	FD14-1210-06
3/8	1 1/8-12 UNF-2A	1	39.1	(1.54)	24.4	(.96)	38.1	(1 1/2)	41-81	(30-60)*	FD14-4002-14-06	FD14-1206-09	FD14-1210-06
3/8	1/2-14 DRYSEAL NPTF	1	40.6	(1.60)	24.4	(.96)	27.0	(1 1/16)	-	-	FD14-4002-27-06*	None Needed	FD14-1210-06
3/8	1/2-14 UNS-2A	1	38.6	(1.52)	24.4	(.96)	27.0	(1 1/16)	27-33	(20-24)*	FD14-4002-22-06*	FD14-1206-01	FD14-1210-06
3/8	1/2-20 UNF-2A	1	38.6	(1.52)	24.4	(.96)	27.0	(1 1/16)	27-33	(20-24)*	FD14-4002-01-06*	FD14-1206-01	FD14-1210-06
3/8	1-18 UNS-2A	1	39.1	(1.54)	24.4	(.96)	31.8	(1 1/4)	41-81	(30-60)*	FD14-4002-06-06	FD14-1206-07	FD14-1210-06
3/8	3/4-14 DRYSEAL NPTF	1	43.8	(1.72)	24.4	(.96)	31.8	(1 1/4)	-	-	FD14-4002-26-06	None Needed	FD14-1210-06
3/8	3/4-16 UNF-2A	1	39.1	(1.54)	24.4	(.96)	31.8	(1 1/4)	41-68	(30-50)*	FD14-4002-09-06	FD14-1206-04	FD14-1210-06
3/8	5/8-18 UNF-2A	1	38.6	(1.52)	24.4	(.96)	27.0	(1 1/16)	27-54	(20-40)*	FD14-4002-08-06*	FD14-1206-03	FD14-1210-06
3/8	7/8-14 UNF-2A	1	39.1	(1.54)	24.4	(.96)	31.8	(1 1/4)	41-81	(30-60)*	FD14-4002-10-06	FD14-1206-06	FD14-1210-06
3/8	7/8-18 UNS-2A	1	39.1	(1.54)	24.4	(.96)	31.8	(1 1/4)	41-81	(30-60)*	FD14-4002-07-06	FD14-1206-06	FD14-1210-06
3/8	9/16-18 UNF-2A	1	38.6	(1.52)	24.4	(.96)	27.0	(1 1/16)	27-54	(20-40)*	FD14-4002-12-06*	FD14-1206-02	FD14-1210-06

*CAUTION: Failure to meet minimum assembly torque could result in fluid leakage.

Dimensions (Metric Thread)

Body Size	Thread Size	Fig.	Dimensions		Hex		Min. Assy. Torque	Part Number Assembly (includes Gasket & Cap)	Gasket (Copper-Crush)	Cap (Brass)			
			A	B	(in)	(in)					N-m	(lbs-ft)	
3/8	M12 X 1.5 6g	1	38.6	(1.52)	24.4	(.96)	27.0	(1 1/16)	27-33	(20-24)*	FD14-4002-23-06*	FD14-1206-01	FD14-1210-06
3/8	M12 X 1.75 6g	1	38.6	(1.52)	24.4	(.96)	27.0	(1 1/16)	27-33	(20-24)*	FD14-4002-25-06*	FD14-1206-01	FD14-1210-06
3/8	M14 X 1.25 6g	1	38.6	(1.52)	24.4	(.96)	27.0	(1 1/16)	27-33	(20-24)*	FD14-4002-03-06*	FD14-1206-02	FD14-1210-06
3/8	M14 X 1.5 6g	1	38.6	(1.52)	24.4	(.96)	27.0	(1 1/16)	27-33	(20-24)*	FD14-4002-24-06*	FD14-1206-02	FD14-1210-06
3/8	M18 X 1.5 6g	1	38.6	(1.52)	24.4	(.96)	31.8	(1 1/4)	27-33	(20-24)*	FD14-4002-02-06*	FD14-1206-04	FD14-1210-06
3/8	M20 X 1.5 6g	1	39.1	(1.54)	24.4	(.96)	31.8	(1 1/4)	41-81	(30-60)*	FD14-4002-16-06	FD14-1206-05	FD14-1210-06
3/8	M22 X 1.5 6g	1	39.1	(1.54)	24.4	(.96)	31.8	(1 1/4)	41-81	(30-60)*	FD14-4002-18-06	FD14-1206-06	FD14-1210-06
3/8	M24 X 1.5 6g	1	39.1	(1.54)	24.4	(.96)	31.8	(1 1/4)	41-81	(30-60)*	FD14-4002-19-06	FD14-1206-07	FD14-1210-06
3/8	M24 X 2 6g	1	39.1	(1.54)	24.4	(.96)	31.8	(1 1/4)	41-81	(30-60)*	FD14-4002-11-06	FD14-1206-07	FD14-1210-06
3/8	M25 X 1.5 6g	1	39.1	(1.54)	24.4	(.96)	31.8	(1 1/4)	41-81	(30-60)*	FD14-4002-17-06	FD14-1206-07	FD14-1210-06
3/8	M27 X 2 6g	1	36.3	(1.43)	24.4	(.96)	38.1	(1 1/2)	41-81	(30-60)*	FD14-4002-29-06	FD14-1206-06	FD14-1210-06
3/8	M30 X 1.5 6g	1	39.1	(1.54)	24.4	(.96)	38.1	(1 1/2)	41-81	(30-60)*	FD14-4002-21-06	FD14-1206-10	FD14-1210-06

*CAUTION: Failure to meet minimum assembly torque could result in fluid leakage.

Dimensions (Female Half NPTF, Valved)

Body Size	Thread Size	Fig.	Dimensions		Hex	Part Number Assembly			
P			A	B	(in)				
3/8	3/4-14 Dryseal NPTF	2	46.5	(1.83)	45.7	(1.80)	33.0	(1 5/16)	FD14-1001-12-06

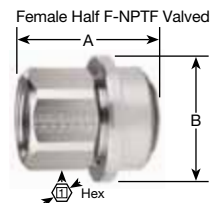

Figure 2

Dimensions (Female Half Assembly, Non-Valved)

Body Size	Hose Size	Fig.	Dimensions		Part Number Assembly		
P			A	B			
3/8	5/8" SOCKETLESS™	3	59.4	(2.34)	38.1	(1.50)	FD14-4003-10-06

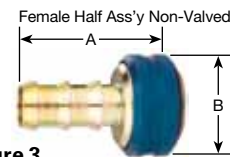

Figure 3

FD14 Series

Oil Drain Coupling

Dimensions (Cap Molded Rubber)

Body Size	Fig.	Dimensions		Part Number Cap (Buna-N)		
		A	B			
3/8	4	13.2	(.519)	35.6	(1.40)	FD14-1204-06

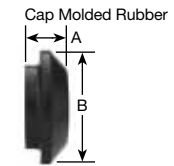

Figure 4

Dimensions (Cap)

Body Size	Fig.	Dimensions		Part Number Cap (Buna-N)		
		A	B			
3/8	5	18.4	(.726)	31.8	(1.25)	FD14-1210-06

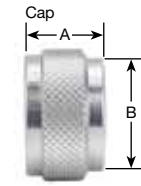

Figure 5

Swivel Joint

Body Size	Fig.	Thread Size	Cap	Part Number (Buna-N)
3/8	6	3/4-14	Dryseal NPTF	FD14-1004-12-12



Figure 6



FD31 Series

Enerpac Interchange



The FD31 Series Hydraulic Jack/Enerpac Interchange is designed for high pressure applications up to 700 bar (10,000 psi). The Eaton FD31 interchanges with the Parker® 3,000 Series Coupling.

Product Features

- Thread together design
- Seal material – Nitrile
- 700 bar (10,000 psi) operating pressure
- Body material – High resistance carbon steel with zinc trivalent chromate plating

Applications

- Hydraulic jack
- Portable hydraulic rams



Physical Characteristics

Body Size	Max. Operating Pressure (Static) Connected		Min. Burst Pressure Connected		Rated Flow	
	bar	(psi)	bar	(psi)	L/min	(gpm)
1/4	700	(10,000)	2,200	(31,900)	12	(3)
3/8	700	(10,000)	18,50	(26,800)	23	(6)

* Connect and disconnect under pressure not allowed

Dimensions

Part Number	Coupling Type	Body Size	Port Size	Thread	Type	Fig.	Dimensions					
							A	B	Hex Ⓛ			
							mm	(in)	mm	(in)	mm	(in)
FD31-1001-04-04	Female	1/4	1/4	1/4-18	Male NPT	1	60,8	(2.39)	28,0	(1.10)	22	.87
FD31-1002-04-04	Male	1/4	1/4	1/4-18	Female NPT	2	32,5	(1.28)	28,0	(1.10)	19	.75
FD31-1001-06-06	Female	3/8	3/8	3/8-18	Male NPT	1	72,2	(2.84)	35,0	(1.38)	24	.94
FD31-1002-06-06	Male	3/8	3/8	3/8-18	Female NPT	2	40,0	(1.57)	35,0	(1.38)	32	1.26

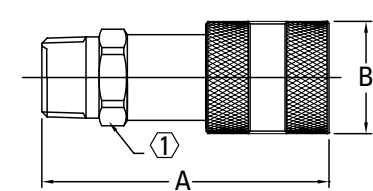

Figure 1

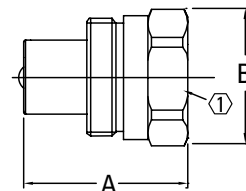

Figure 2

Dust Caps and Dust Plugs

Coupling Size	Part Number	Coupling Type	Cap Material
1/4	FD31-1005-04	Female	Aluminum
3/8	FD31-1005-06	Female	Aluminum

Coupling Size	Part Number	Coupling Type	Cap Material
1/4	FD31-1004-04	Male	Aluminum
3/8	FD31-1004-06	Male	Aluminum

FD69 Series

10,000 psi Water Blast



The FD69 Series "Arc Latch™" design has a greater surface contact area for long service life in rugged high pressure and water blast applications. The maximum operating pressure is 10,000 psi with 40,000 psi minimum burst pressure.

Product Features

- Safety sleeve lock guards against accidental disconnection
- Smooth bore "straight through" design for high flow fluid requirements
- Heavy duty back-up ring to prevent O-Ring extrusion
- Available in plated steel and stainless steel for added corrosion resistance
- Standard seal material – Buna-N
- Standard body material – High resistance carbon steel with zinc trivalent plating or stainless steel

Physical Characteristics

Coupling Size	Max. Operating Pressure		Min. Burst Pressure Connected		Vacuum Connected Only	Rated Flow		Air Inclusion	Fluid Loss
	bar	(psi)	bar	(psi)	(in./Hg)	L/min	(gpm)	cc. max.	cc.max.
3/8	689	(10,000)	2,758	(40,000)	28	170	(45)	-	-



Applications

- High pressure water blast

Flow Data

Pressure Drop Versus Flow Graph

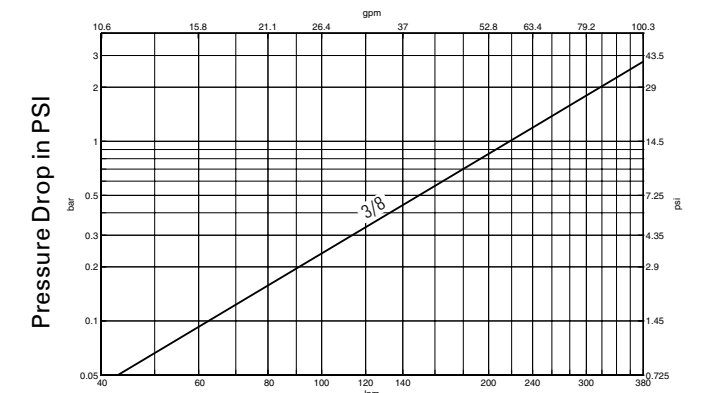

Gallons Per Minute Flow
Test Fluid: Water at 70°F

FD69 Series

10,000 psi Water Blast

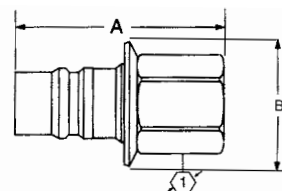

Figure 1

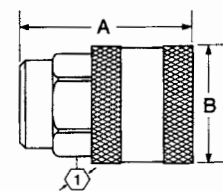

Figure 2

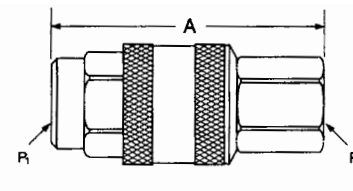

Figure 3

Dimensions (Female NPT)

Part Number	Buna-N	Viton	EPR	Coupling Type	Body Size	Port Size	Thread	Type	Fig.	Dimensions A		Dimensions B		Hex Ⓛ		
Steel											mm	(in)	mm	(in)	mm	(in)
FD69-1002-06-08	FD69-1002-06-08	FD69-1002-06-08	FD69-1002-06-08	Male*	1/2	3/8	3/8-18	Female NPT	1	47	(1.85)	41.7	(1.64)	25.4	(1.00)	
FD69-1001-06-08	FD69-1026-06-08	FD69-1028-06-08	FD69-1028-06-08	Female	1/2	3/8	3/8-18	Female NPT	2	54.1	(2.13)	41.1	(1.62)	31.8	(1.25)	
FD69-1002-08-08	FD69-1002-08-08	FD69-1002-08-08	FD69-1002-08-08	Male*	1/2	1/2	1/2-14	Female NPT	1	59.4	(2.34)	41.7	(1.64)	28.4	(1.12)	
FD69-1001-08-08	FD69-1026-08-08	FD69-1028-08-08	FD69-1028-08-08	Female	1/2	1/2	1/2-14	Female NPT	2	54.1	(2.13)	41.1	(1.62)	31.8	(1.25)	
Stainless Steel																
FD69-1012-08-08	FD69-1012-08-08	FD69-1012-08-08	FD69-1012-08-08	Male*	1/2	1/2	1/2-14	Female NPT	1	59.4	(2.34)	41.7	(1.64)	28.4	(1.12)	
FD69-1011-08-08	-	-	-	Female	1/2	1/2	1/2-14	Female NPT	2	54.1	(2.13)	41.1	(1.62)	33.3	(1.31)	

*Male halves contain no seals.

Part Number	Buna-N	Viton	EPR	Coupling Type	Body Size	Port Size	Thread (P)	Thread (P1)	Type	Fig.	Dimensions A	
Steel											mm	(in)
FD69-1000-080808	FD69-1027-080808	FD69-1029-080808	FD69-1029-080808	Complete	1/2	1/2	1/2-14	1/2-14	Female NPT	3	87.1	(3.43)
FD69-1000-080806	FD69-1027-080806	FD69-1029-080806	FD69-1029-080806	Complete	1/2	1/2 & 3/8	1/2-14	3/8-18	Female NPT	3	87.1	(3.43)
FD69-1000-060808	FD69-1027-060808	FD69-1029-060808	FD69-1029-060808	Complete	1/2	3/8 & 1/2	3/8-18	1/2-14	Female NPT	3	74.7	(2.94)
FD69-1000-060806	FD69-1027-060806	FD69-1029-060806	FD69-1029-060806	Complete	1/2	3/8	3/8-18	3/8-18	Female NPT	3	74.7	(2.94)
Stainless Steel												
FD69-1010-080808	-	-	-	Complete	1/2	1/2	1/2-14	1/2-14	Female NPT	3	87.1	(3.43)

Repair Kit, Female Interface Seal

Part Number	Buna-N	Viton	EPR	Coupling Size
FF10166	-	-	-	1/2

FD83 Series

Full Flow Dual Interlock



Product Features

- Dual interlock safety feature eliminates accidental opening of coupling when disconnected with the use of a patent pending locking pin design and lever handle
- Design provides reliable performance and minimal spillage during maintenance or service
- Standard seal material – EPDM, additional material available on request
- Standard body material – 303 stainless steel, additional material available on request
- Full-flow capability
- Available color coded bumper seals available
- Identical coupling halves
- Maintenance and service friendly
- 303 stainless steel material provides broad fluid compatibility
- 3/4" and 1" Female NPT port threads or hose barb

Physical Characteristics

Coupling Size	Max. Operating Pressure			Min. Burst Pressure			Rated Flow	Fluid Loss
	Connected	Male Half	Female Half	Connected	Male Half	Female Half		
	bar (psi)	bar (psi)	bar (psi)	bar (psi)	bar (psi)	bar (psi)	L/min (USgpm)	cc. max
1	10 (150)	10 (150)	10 (150)	20 (300)	20 (300)	20 (300)	189 (50)	5.0

Dimensions

Part Number	Body Size	Port Size	Thread	Type	Fig.	Dimensions A		Dimensions B		Hex Ⓛ	
						mm	(in)	mm	(in)	mm	(in)
FD83-2052-16-16	1	1	1-11 1/2	Female NPT	1	95,5	(3.76)	71,6	(2.82)	41	(1.63)
FD83-2052-12-16	1	3/4	3/4-14	Female NPT	1	70,1	(2.76)	71,6	(2.83)	41	(1.63)
FD83-2046-16-16	1	1	NA	1" Hose Barb	2	90,2	(3.55)	69,1	(2.72)	--	--

Hose barb adapters available upon request.

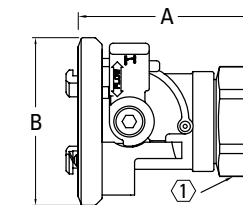

Figure 1

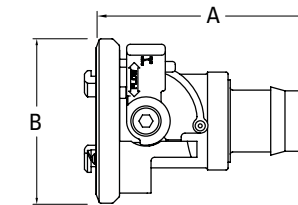
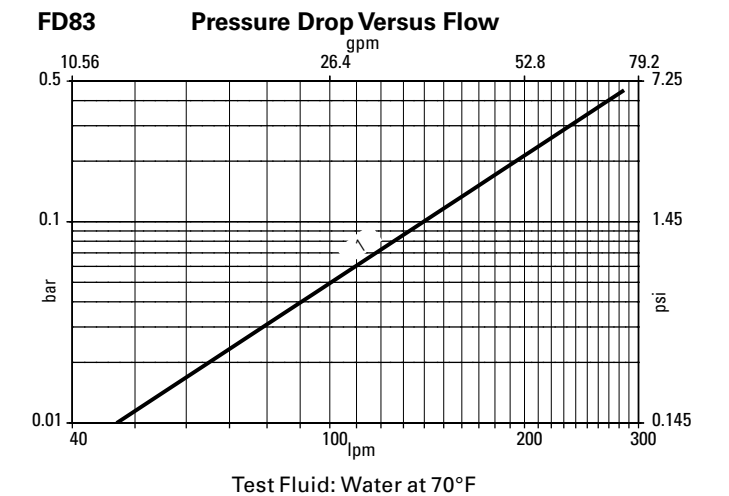

Figure 2

Applications

- Electronics liquid based cooling
- Thermal management systems
- Industrial fluid transfer

Flow Data



SPECIAL APPLICATIONS

SPECIAL APPLICATIONS

5400 Series

Low Air Inclusion Refrigerant



The 5400 Series low air inclusion product line is designed for air conditioning, refrigerant, gaseous and fluid transfer applications.

Product Features

- Brazed or threaded end connections for versatility of installation on tubing or hose
- Tubular valve construction for low fluid loss and air inclusion
- Thread together design allows connection and disconnection against pressure
- Lock washer and jam nut standard for optional bulkhead mounting
- Standard seal material – Neoprene
- Standard adapter material – Steel or Brass
- Standard body material – High resistance carbon steel with zinc trivalent plating

Physical Characteristics

Coupling Size	Max. Operating Pressure Connected		Min. Burst Pressure Connected		Max. Operating Pressure Disconnected Male Half		Female Half		Vacuum Connected Only		Rated Flow	Air Inclusion	Fluid Loss
	bar	(psi)	bar	(psi)	bar	(psi)	bar	(psi)	(in./Hg)	L/min	(gpm)	cc. max.	cc. max.
-4	207	(3,000)	621	(9,000)	172	(2,500)	34	(500)	28	8	(2)	.10	.05
-8	121	(1,750)	359	(5,200)	121	(1,750)	28	(400)	28	53	(14)	.10	.10
-12	48	(700)	145	(2,100)	55	(800)	28	(400)	28	132	(35)	.30	.10
-16	48	(700)	145	(2,100)	48	(700)	21	(300)	28	284	(75)	.50	.20

Applications

- Mobile air conditioning and refrigerant



Flow Data

Pressure Drop Versus Flow Graph

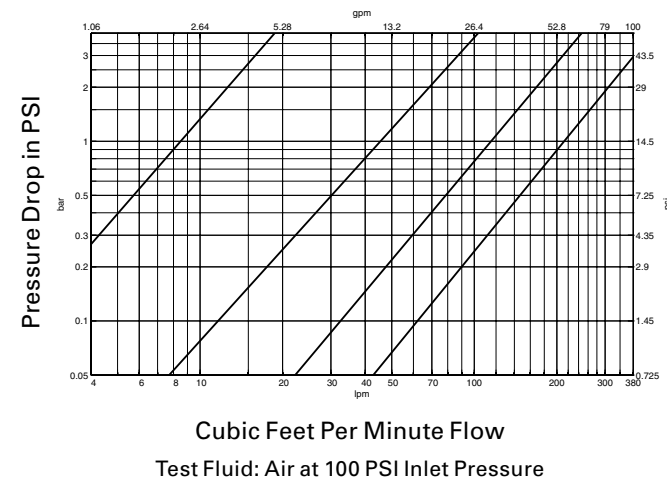

5400 Series

Low Air Inclusion Refrigerant

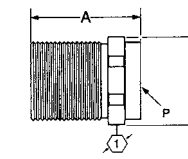

Figure 1

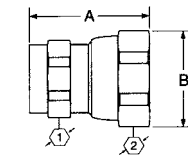

Figure 2

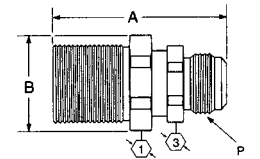

Figure 3

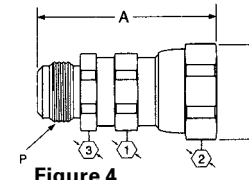

Figure 4

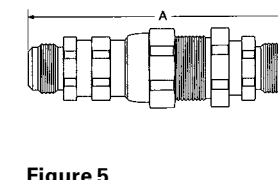

Figure 5

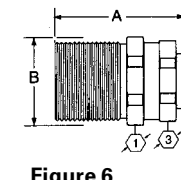

Figure 6

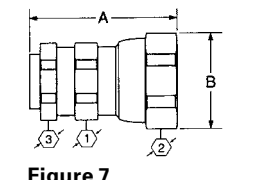

Figure 7

Dimensions – No Adapter

Part Number	Coupling Type	Coupling Size	Body Port Size	Port Thread	Tube O.D. Size	Tube O.D. Type	Fig.	Dimensions		Hex ①	Hex ②	Hex ③
								A	B			
5400-S2-4	Male	-4	2/8	-	-	No Adapter	1	27.4 (1.08)	21.1 (.83)	19.1 (.75)	-	-
5400-S5-4	Female	-4	2/8	-	-	No Adapter	2	33.3 (1.31)	21.1 (.83)	16.0 (.63)	19.1 (.75)	-
5400-S2-8	Male	-8	1/2	-	-	No Adapter	1	34.8 (1.37)	31.8 (1.25)	33.3 (1.31)	-	-
5400-S5-8	Female	-8	1/2	-	-	No Adapter	2	41.4 (1.63)	33.3 (1.31)	25.4 (1.00)	30.2 (1.19)	-
5400-S2-12	Male	-12	3/4	-	-	No Adapter	1	44.2 (1.74)	46.5 (1.83)	41.4 (1.63)	-	-
5400-S5-12	Female	-12	3/4	-	-	No Adapter	2	54.6 (2.15)	45.7 (1.80)	35.1 (1.38)	41.4 (1.63)	-
5400-S2-16	Male	-16	1	-	-	No Adapter	1	46.5 (1.83)	53.3 (2.10)	47.8 (1.88)	-	-
5400-S5-16	Female	-16	1	-	-	No Adapter	2	60.2 (2.37)	56.9 (2.24)	44.5 (1.75)	50.8 (2.00)	-

Dimensions – SAE 37° (JIC)

Part Number	Coupling Type	Coupling Size	Body Port Size	Port Thread	Tube O.D. Size	Tube O.D. Type	Fig.	Dimensions		Hex ①	Hex ②	Hex ③
								A	B			
5410-S17-4-4*	Male	-4	1/4	7/16	7/16-20	SAE 37° (JIC)	3	47.8 (1.88)	21.1 (.83)	19.1 (.75)	-	16.0 (.63)
5410-S14-4-4*	Female	-4	1/4	7/16	7/16-20	SAE 37° (JIC)	4	49.0 (1.93)	21.1 (.83)	16.0 (.63)	19.1 (.75)	15.7 (.62)
5410-4-4*	Complete	-4	1/4	7/16	7/16-20	SAE 37° (JIC)	5	89.9 (3.54)	-	-	-	-
5410-S17-6-4*	Male	-4	1/4	9/16	9/16-18	SAE 37° (JIC)	3	48.0 (1.89)	21.1 (.83)	19.1 (.75)	-	16.0 (.63)
5410-S14-6-4*	Female	-4	1/4	9/16	9/16-18	SAE 37° (JIC)	4	49.3 (1.94)	21.1 (.83)	16.0 (.63)	19.1 (.75)	15.7 (.62)
5410-6-4*	Complete	-4	1/4	9/16	9/16-18	SAE 37° (JIC)	5	90.4 (3.56)	-	-	-	-
5410-S17-6-8*	Male	-8	1/2	9/16	9/16-18	SAE 37° (JIC)	3	55.4 (2.18)	31.8 (1.25)	28.7 (1.13)	-	25.4 (1.00)
5410-S14-6-8*	Female	-8	1/2	9/16	9/16-18	SAE 37° (JIC)	4	61.7 (2.43)	33.3 (1.31)	25.4 (1.00)	30.2 (1.19)	25.4 (1.00)
5410-6-8*	Complete	-8	1/2	9/16	9/16-18	SAE 37° (JIC)	5	107.4 (4.23)	-	-	-	-
5410-S17-8-8*	Male	-8	1/2	3/4	3/4-16	SAE 37° (JIC)	3	57.9 (2.28)	31.8 (1.25)	28.7 (1.13)	-	25.4 (1.00)
5410-S14-8-8*	Female	-8	1/2	3/4	3/4-16	SAE 37° (JIC)	4	64.3 (2.53)	33.3 (1.31)	25.4 (1.00)	30.2 (1.19)	25.4 (1.00)
5410-8-8*	Complete	-8	1/2	3/4	3/4-16	SAE 37° (JIC)	5	112.8 (4.44)	-	-	-	-
5410-S17-10-12*	Male	-12	3/4	7/8	7/8-14	SAE 37° (JIC)	3	69.9 (2.75)	46.5 (1.83)	41.4 (1.63)	-	35.1 (1.38)
5410-S14-10-12*	Female	-12	3/4	7/8	7/8-14	SAE 37° (JIC)	4	80.3 (3.16)	45.7 (1.80)	35.1 (1.38)	41.1 (1.62)	35.1 (1.38)
5410-10-12*	Complete	-12	3/4	7/8	7/8-14	SAE 37° (JIC)	5	135.4 (5.33)	-	-	-	-
5410-S17-12-12*	Male	-12	3/4	1 1/16	1 1/16-12	SAE 37° (JIC)	3	72.6 (2.86)	46.5 (1.83)	41.4 (1.63)	-	35.1 (1.38)
5410-S14-12-12*	Female	-12	3/4	1 1/16	1 1/16-12	SAE 37° (JIC)	4	83.1 (3.27)	45.7 (1.80)	35.1 (1.38)	41.1 (1.62)	35.1 (1.38)
5410-12-12*	Complete	-12	3/4	1 1/16	1 1/16-12	SAE 37° (JIC)	5	140.7 (5.54)	-	-	-	-
5410-S17-16-16*	Male	-16	1	1 5/16	1 5/16-12	SAE 37° (JIC)	3	75.9 (2.99)	53.3 (2.10)	47.8 (1.88)	-	44.5 (1.75)
5410-S14-16-16*	Female	-16	1	1 5/16	1 5/16-12	SAE 37° (JIC)	4	89.7 (3.53)	56.9 (2.24)	44.5 (1.75)	50.8 (2.00)	44.5 (1.75)
5410-16-16*	Complete	-16	1	1 5/16	1 5/16-12	SAE 37° (JIC)	5	149.6 (5.89)	-	-	-	-

*Couplings must be ordered by components as shown on page 66.

5400 Series

Low Air Inclusion Refrigerant

Dimensions – Braze Tubing Adapter

Part Number	Coupling Neoprene Type	Coupling Size	Body Size	Port Size	Tube Thread	Tube O.D. Type	Fig.	Dimensions					
								A	B	Hex ①	Hex ②	Hex ③	
								mm (in)	mm (in)	mm (in)	mm (in)	mm (in)	mm (in)
5401-S17-4-4*	Male	-4	1/4	-	1/4	Braze Tubing Adapter	6	38.6 (1.52)	21.1 (.83)	19.1 (.75)	-	-	16.0 (.63)
5401-S14-4-4*	Female	-4	1/4	-	1/4	Braze Tubing Adapter	7	39.9 (1.57)	21.1 (.83)	16.0 (.63)	19.1 (.75)	16.0 (.63)	
5401-S17-6-4*	Male	-4	1/4	-	3/8	Braze Tubing Adapter	6	38.6 (1.52)	21.1 (.83)	19.1 (.75)	-	-	16.0 (.63)
5401-S14-6-4*	Female	-4	1/4	-	3/8	Braze Tubing Adapter	7	39.9 (1.57)	21.1 (.83)	16.0 (.63)	19.1 (.75)	16.0 (.63)	
5410-S17-6-8*	Male	-8	1/2	-	3/8	Braze Tubing Adapter	6	44.5 (1.75)	33.3 (1.31)	28.7 (1.13)	-	-	25.4 (1.00)
5401-S14-6-8*	Female	-8	1/2	-	3/8	Braze Tubing Adapter	7	50.8 (2.00)	33.3 (1.31)	25.4 (1.00)	30.2 (1.19)	25.4 (1.00)	
5401-S17-8-8*	Male	-8	1/2	-	1/2	Braze Tubing Adapter	6	44.5 (1.75)	33.3 (1.31)	28.7 (1.13)	-	-	25.4 (1.00)
5401-S14-8-8*	Female	-8	1/2	-	1/2	Braze Tubing Adapter	7	50.8 (2.00)	33.3 (1.31)	25.4 (1.00)	30.2 (1.19)	25.4 (1.00)	
5401-S17-10-12*	Male	-12	3/4	-	5/8	Braze Tubing Adapter	6	62.7 (2.47)	45.7 (1.80)	41.4 (1.63)	-	-	35.1 (1.38)
5401-S14-10-12*	Female	-12	3/4	-	5/8	Braze Tubing Adapter	7	73.2 (2.88)	45.7 (1.80)	35.1 (1.38)	41.4 (1.63)	35.1 (1.38)	
5401-S17-12-12*	Male	-12	3/4	-	3/4	Braze Tubing Adapter	6	62.7 (2.47)	45.7 (1.80)	41.4 (1.63)	-	-	35.1 (1.38)
5401-S14-12-12*	Female	-12	3/4	-	3/4	Braze Tubing Adapter	7	73.2 (2.88)	45.7 (1.80)	35.1 (1.38)	41.4 (1.63)	35.1 (1.38)	
5401-S17-16-16*	Male	-16	1	-	1	Braze Tubing Adapter	6	71.1 (2.80)	56.9 (2.24)	47.8 (1.88)	-	-	44.5 (1.75)
5401-S14-16-16*	Female	-16	1	-	1	Braze Tubing Adapter	7	84.8 (3.34)	56.9 (2.24)	44.5 (1.75)	50.8 (2.00)	44.5 (1.75)	

*Couplings must be ordered by components as shown on page 66.

Dust Caps and Dust Plugs

Dust Cap with Gasket	Dust Plug with Gasket	Coupling Size
5400-S6-4	5400-S8-4	-4
5400-S6-8	5400-S8-8	-8
5400-S6-12	5400-S8-12	-12
5400-S6-16	5400-S8-16	-16

Adapter SAE 37° (JIC)

O-ring	Brass	Steel	Coupling Size	Thread	Tube O.D. Size
22546-12	202220-4-4B	202220-4-4S	-4	7/16-20	1/4
22546-12	202220-6-4B	202220-6-4S	-4	9/16-18	3/8
22546-17	202220-6-8B	202220-6-8S	-8	9/16-18	3/8
22546-17	202220-8-8B	202220-8-8S	-8	3/4-16	1/2
22546-23	202220-10-12B	202220-10-12S	-12	7/8-14	5/8
22546-23	202220-12-12B	202220-12-12S	-12	1 1/16-12	3/4
22546-28	202220-16-16B	202220-16-16S	-16	1 3/16-12	1

Adapter – Braze

O-ring	Brass	Steel	Coupling Size	Thread	Tube O.D. Size
22546-12	202208-4-4B	-	-4	1/2-20	1/4
22546-17	202208-4-8B	-	-8	7/8-20	1/2
22546-12	202208-6-4B	-	-4	1/2-20	3/8
22546-17	202208-6-8B	-	-8	7/8-20	3/8
22546-17	202208-8-8B	-	-8	7/8-20	1/2
22546-17	202208-10-8B	-	-8	7/8-20	5/8
22546-23	202208-10-12B	-	-12	1 1/4-18	5/8
22546-23	202208-12-12B	-	-12	1 1/4-18	3/4
22546-23	202202-14-12B	-	-16	1 1/4-18	7/8
22546-28	202208-14-16B	-	-16	1 19/32-20	7/8
22546-28	202208-16-16B	-	-16	1 19/32-20	1
22546-28	202208-18-16B	-	-16	1 19/32-20	1 1/8
22546-28	202208-22-16B	-	-16	1 19/32-20	1 1/4

Hose Fitting SAE 100R5[†]

O-ring	Fitting Assembly	Coupling Size	Hose Size	Dimensions	
				Thread	D
				mm	(in)
22546-12	487-4-4S	-4	-4	1/2-20	23.4 (.92)
22546-12	487-4-6S	-4	-6	1/2-20	24.4 (.96)
22546-17	487-8-6S	-8	-6	7/8-20	24.4 (.96)
22546-17	487-8-8S	-8	-8	7/8-20	26.9 (1.06)
22546-23	487-12-10S	-12	-10	1 1/4-18	27.2 (1.07)
22546-28	487-16-16S	-16	-16	1 19/32-20	25.7 (1.01)

[†]Additional dash styles available.

Dust Cap Dust Plug



Adapter SAE 37° (JIC)

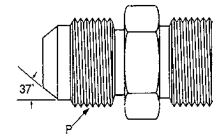

Adapter – Braze (O-ring Required)

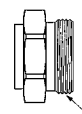

Hose Fitting SAE 100R5 (O-ring Required)

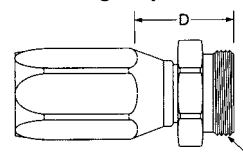

5400 Series

Low Air Inclusion Refrigerant

For assemblies, order by components as shown by base number and dash (-) size below. Example, if a 5401-S14-10-12 is required, order as components, (1) 5400-S5-12, (1) 202208-10-12B Adapter and (1) 22546-23 O-ring.

Assembly Part Number	5400-S2 Female Half	Quantity	5400-S5 Male Half	Quantity	202208-Brass Braze-On Adapter	Quantity	202220-Steel 37° SAE Adapter	Quantity	22546 O-ring	Quantity
5401-S14-10-12			-12	1	-10-12B	1			-23	1
5401-S14-10-8			-8	1	-10-8B				-17	1
5401-S14-12-12			-12	1	-12-12B	1			-23	1
5401-S14-16-16			-16	1	-16-16B	1			-28	1
5401-S14-4-4			-4	1	-4-4B	1			-12	1
5401-S14-6-4			-4	1	-6-4B	1			-12	1
5401-S14-6-8			-8	1	-6-8B	1			-17	1
5401-S14-8-8			-8	1	-8-8B	1			-17	1
5401-S17-10-12	-12	1			-10-12B	1			-23	1
5401-S17-10-8	-8	1			-10-8B	1			-17	1
5401-S17-12-12	-12	1			-12-12	1			-23	1
5401-S17-14-16	-16	1			-16-16	1			-28	1
5401-S17-4-4	-4	1			-4-4B	1			-17	1
5401-S17-6-4	-4	1			-6-4B	1			-12	1
5401-S17-6-8	-8	1			-6-8B	1			-17	1
5401-S17-8-8	-8	1			-8-8B	1			-17	1
5410-12-12	-12	1	-12	1			-12-12S	2	-23	2
5410-16-16	-16	1	-16	1			-16-16S	2	-28	2
5410-4-4	-4	1	-4	1			-4-4S	2	-12	2
5410-6-8	-8	1	-8	1			-6-8S	2	-17	2
5410-8-8	-8	1	-8	1			-8-8S	2	-17	2
5410-S14-10-12			-12	1			-10-12S	1	-23	1
5410-S14-12-12			-12	1			-12-12S	1	-23	1
5410-S14-16-16			-16	1			-16-16S	1	-28	1
5410-S14-4-4			-4	1			-4-4S	1	-12	1
5410-S14-6-4			-4	1			-6-4S	1	-12	1
5410-S14-6-8			-8	1			-6-8S	1	-17	1
5410-S14-8-8			-8	1			-8-8S	1	-17	1
5410-S17-10-12	-12	1					-10-12S	1	-23	1
5410-S17-12-12	-12	1					-12-12S	1	-23	1
5410-S17-16-16	-16	1					-16-16S	1	-28	1
5410-S17-4-4	-4	1					-4-4S	1	-12	1
5410-S17-6-4	-4	1					-6-4S	1	-12	1
5410-S17-6-8	-8	1					-6-8S	1	-17	1
5410-S17-8-8	-8	1					-8-8S	1	-17	1

FD40 Series

MIL-C-4109 Interchange



The FD40 Series offers a one-hand push-to-connect latch ideal for compressed air service, utilizing a ball latching mechanism. The female half features self-sealing poppet valves, preventing air loss while disconnected. The male half uses a straight through non-valved design.

Product Features

- Automatic sleeve for one-hand push-to-connect operation with pin latching mechanism
- Protective sleeve lock prevents accidental disconnection
- Meet dimensional requirements of MIL-C-4109 for industrial interchangeability
- Swivels 360°, eliminating hose kinking
- Standard seal material – Buna-N
- Standard body material (Male) – High resistance carbon steel with zinc trivalent chromate plating
- Standard seal material – Buna-N
- Standard body material (Female) – Brass

Physical Characteristics

Coupling Size	Max. Operating Pressure		Min. Burst Pressure Female Half Only		Connected		Vacuum Connected Only
	bar	(psi)	bar	(psi)	bar	(psi)	(in./Hg)
-04	21	(300)	210	(3,000)	560	(8,000)	28
-06	21	(300)	210	(3,000)	560	(8,000)	28
-08	21	(300)	210	(3,000)	560	(8,000)	28

Applications

- Compressed air
- Pneumatic tools
- MIL-C-4109 Interchange



Flow Data

Pressure Drop Versus Flow Graph

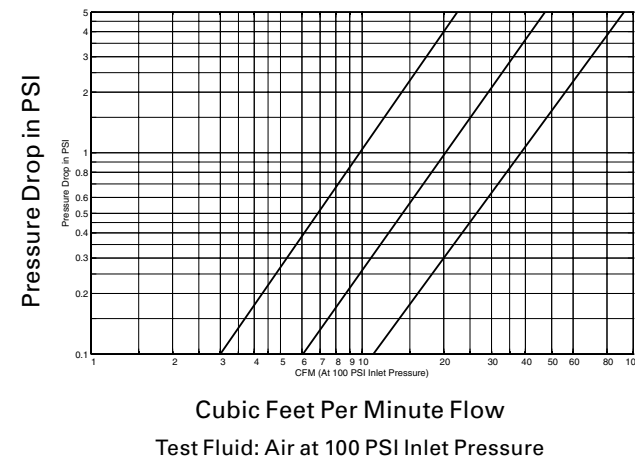

FD40 Series

NFPA standard T3.20.15
HTMA Interchange

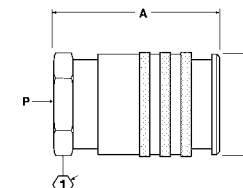

Figure 1

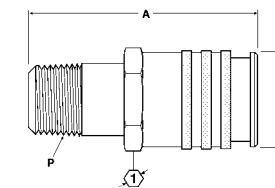

Figure 2

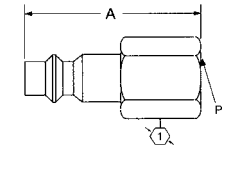

Figure 3

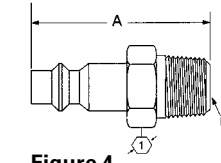

Figure 4

Dimensions — Female Pipe

Part Number	Coupling Type	Body Size	Port Size	Thread	Type	Fig.	Dimensions A		B		Hex ①	
							mm	(in)	mm	(in)	mm	(in)
FD40-1013-02-04	Male	1/4	1/8	1/8-27	Female NPT	3	30.7	(1.21)	-	-	14.2	(.56)
FD40-1054-04-04	Female	1/4	1/4	1/4-18	Female NPT	1	55.1	(2.17)	30.2	(1.19)	17.5	(.69)
FD40-1013-04-04	Male	1/4	1/4	1/4-18	Female NPT	3	41.1	(1.62)	-	-	15.7	(.62)
FD40-1054-06-04	Female	1/4	3/8	3/8-18	Female NPT	1	56.6	(2.23)	30.2	(1.19)	19.1	(.75)
FD40-1013-06-04	Male	1/4	3/8	3/8-18	Female NPT	3	45.7	(1.80)	-	-	22.4	(.88)
FD40-1054-04-06	Female	3/8	1/4	1/4-18	Female NPT	1	53.3	(2.10)	35.1	(1.38)	22.4	(.88)
FD40-1054-06-06	Female	3/8	3/8	3/8-18	Female NPT	1	59.7	(2.35)	35.1	(1.38)	22.4	(.88)
FD40-1013-06-06	Male	3/8	3/8	3/8-18	Female NPT	3	48.3	(1.90)	-	-	22.4	(.88)
FD40-1054-08-08	Female	1/2	1/2	1/2-14	Female NPT	1	78.0	(3.07)	43.4	(1.71)	25.4	(1.00)
FD40-1013-08-08	Male	1/2	1/2	1/2-14	Female NPT	3	61.0	(2.40)	-	-	28.4	(1.12)

Dimensions — Male Pipe

Part Number	Coupling Type	Coupling Size	Body Size	Port Size	Thread	Type	Fig.	Dimensions A		B		Hex ①	
								mm	(in)	mm	(in)	mm	(in)
FD40-1055-04-04	Female	-04	1/4	1/4	1/4-18	Male NPT	2	57.4	(2.26)	30.2	(1.19)	17.5	(0.69)
FD40-1014-04-04	Male	-04	1/4	1/4	1/4-18	Male NPT	4	42.9	(1.69)	-	-	14.2	(0.56)
FD40-1055-06-04	Female	-04	1/4	3/8	3/8-18	Male NPT	2	57.4	(2.26)	30.2	(1.19)	17.5	(0.69)
FD40-1014-06-04	Male	-04	1/4	3/8	3/8-18	Male NPT	4	44.5	(1.75)	-	-	17.5	(0.69)
FD40-1014-02-04	Male	-04	1/4	1/8	1/8-27	Male NPT	4	38.1	(1.50)	-	-	12.7	(0.50)
FD40-1055-06-06	Female	-06	3/8	3/8	3/8-18	Male NPT	2	59.7	(2.35)	35.1	(1.38)	22.4	(0.88)
FD40-1014-06-06	Male	-06	3/8	3/8	3/8-18	Male NPT	4	47.8	(1.88)	-	-	17.5	(0.69)
FD40-1014-04-06	Male	-06	3/8	1/4	1/4-18	Male NPT	4	47.8	(1.88)	-	-	15.7	(0.62)
FD40-1014-08-06	Male	-06	3/8	1/2	1/2-14	Male NPT	4	54.1	(2.13)	-	-	22.4	(0.88)
FD40-1055-08-08	Female	-08	1/2	1/2	1/2-14	Male NPT	2	75.7	(2.98)	38.1	(1.50)	25.4	(1.00)
FD40-1014-08-08	Male	-08	1/2	1/2	1/2-14	Male NPT	4	62.0	(2.44)	-	-	22.4	(0.88)
FD40-1014-06-08	Male	-08	1/2	3/8	3/8-18	Male NPT	4	55.4	(2.18)	-	-	17.5	(0.69)

FD41 Series

ARO 210 Interchange



The FD41 Series ARO 210 interchange is designed for compressed air service with a self-sealing female half and straight through male half. The FD41 assures high flow with low pressure drop for peak tool performance.

Product Features

- Designed to interchange with ARO 210 Series
- Automatic sleeve for one hand push-to-connect operation.
- Swivels 360°, eliminating hose kinking
- Standard seal material – Buna-N
- Standard body material – High resistance carbon steel with zinc trivalent chromate plating

Applications

- Compressed air
- Pneumatic tools
- ARO 210 Interchange



Physical Characteristics

Coupling Size	Max. Operating Pressure		Min. Burst Pressure Female Half Only		Connected		Vacuum Connected Only
	bar	(psi)	bar	(psi)	bar	(psi)	(in./Hg)
-04	21	(300)	210	(3,000)	560	(8,000)	28

Dimensions – Female Pipe

Part Number	Coupling Type	Coupling Size	Body Size	Port Size	Thread	Type	Fig.	Dimensions			Hex		
								A	B	Hex			
								mm	(in)	mm	(in)	mm	(in)
FD41-1000-02-04	Female	-04	1/4	1/8	1/8-27	Female NPT	1	54.6	(2.15)	28.4	(1.12)	20.6	(.81)
FD41-1000-04-04	Female	-04	1/4	1/4	1/4-18	Female NPT	1	41.1	(1.62)	28.4	(1.12)	20.6	(.81)
FD41-1013-04-04	Male	-04	1/4	1/4	1/4-18	Female NPT	2	37.6	(1.48)	-	-	15.7	(.62)

Dimensions – Male Pipe

Part Number	Coupling Type	Coupling Size	Body Size	Port Size	Thread	Type	Fig.	Dimensions			Hex		
								A	B	Hex			
								mm	(in)	mm	(in)	mm	(in)
FD41-1014-04-04	Male	-04	1/4	1/4	1/4-18	Male NPT	3	40.9	(1.61)	-	-	14.2	(.56)

Flow Data

Pressure Drop Versus Flow Graph

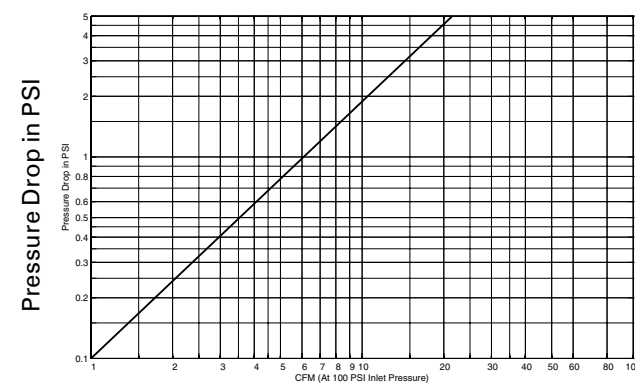

Cubic Feet Per Minute Flow
Test Fluid: Air at 100 PSI Inlet Pressure

FD43 Series

MIL-C-4109 Interchange



The FD43 Series is a manual retract-type ball latch industrial interchange coupling designed specifically for compressed air service. The FD43 Series uses FD40 Series male tips.

Product Features

- Meets dimensional requirements of MIL-C-4109 specifications for industrial interchangeability
- Protective collar to prevent accidental snagging and disconnection
- Manual retract latch design allows quick and easy connection of hose lines
- Swivels 360°, eliminating hose kinking
- Standard seal material – Neoprene
- Standard body material – High resistance carbon steel with zinc trivalent chromate plating

Physical Characteristics

Coupling Size	Max. Operating Pressure		Min. Burst Pressure Female Half Only		Connected		Vacuum Connected Only
	bar	(psi)	bar	(psi)	bar	(psi)	(in./Hg)
-04	21	(300)	210	(3,000)	560	(8,000)	Not Rated
-06	21	(300)	210	(3,000)	560	(8,000)	Not Rated
-08	21	(300)	210	(3,000)	560	(8,000)	Not Rated



Applications

- Compressed air
- Pneumatic tools
- MIL-C-4109 Interchange



Flow Data

Pressure Drop Versus Flow Graph

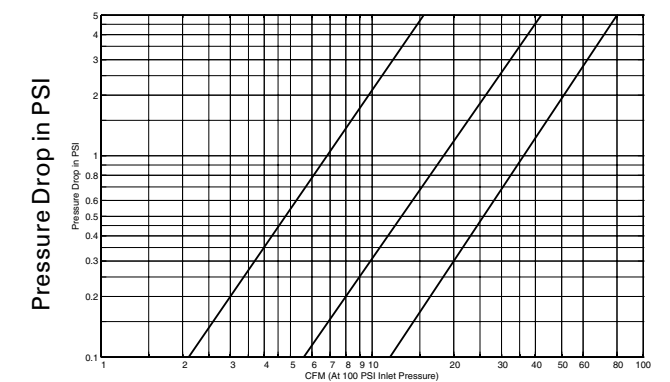

Cubic Feet Per Minute Flow
Test Fluid: Air at 100 PSI Inlet Pressure

FD43 Series
MIL-C-4109 Interchange

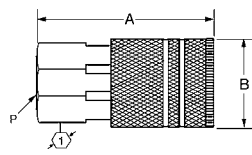

Figure 1

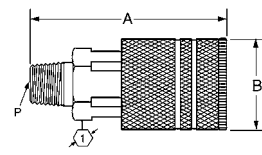

Figure 2

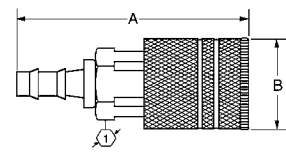

Figure 3

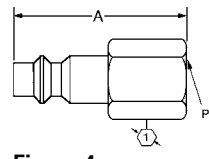

Figure 4

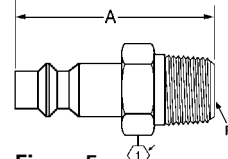

Figure 5

Dimensions — Female Pipe

Part Number	Coupling Type	Coupling Size	Body Size	Port Size	Thread	Type	Fig.	Dimensions					
								A		B		Hex ①	
								mm	(in)	mm	(in)	mm	(in)
FD40-1013-02-04	Male	-04	1/4	1/8	1/8-27	Female NPT	3	30.7	(1.21)	-	-	14.2	(.56)
FD43-1001-04-04	Female	-04	1/4	1/4	1/4-18	Female NPT	1	53.1	(2.09)	22.4	(.88)	19.0	(.75)
FD40-1013-04-04	Male	-04	1/4	1/4	1/4-18	Female NPT	3	41.1	(1.62)	-	-	15.7	(.62)
FD43-1001-06-04	Female	-04	1/4	3/8	3/8-18	Female NPT	1	54.9	(2.16)	22.4	(.88)	20.6	(.81)
FD40-1013-06-04	Male	-04	1/4	3/8	3/8-18	Female NPT	3	45.7	(1.80)	-	-	22.4	(.88)
FD43-1001-06-06	Female	-06	3/8	3/8	3/8-18	Female NPT	1	60.5	(2.38)	26.9	(1.06)	22.4	(.88)
FD40-1013-06-06	Male	-06	3/8	3/8	3/8-18	Female NPT	3	48.3	(1.90)	-	-	22.4	(.88)
FD43-1001-04-06	Female	-06	3/8	1/4	1/4-18	Female NPT	1	60.5	(2.38)	26.9	(1.06)	22.4	(.88)
FD43-1001-08-08	Female	-08	1/2	1/2	1/2-14	Female NPT	1	77.7	(3.06)	30.2	(1.19)	25.4	(1.00)
FD40-1013-08-08	Male	-08	1/2	1/2	1/2-14	Female NPT	3	61.0	(2.40)	-	-	28.4	(1.12)

Dimensions — Male Pipe

Part Number	Coupling Type	Coupling Size	Body Size	Port Size	Thread	Type	Fig.	Dimensions					
								A		B		Hex ①	
								mm	(in)	mm	(in)	mm	(in)
FD40-1014-02-04	Male	-04	1/4	1/8	1/8-27	Male Pipe	4	38.1	(1.50)	-	-	12.7	(0.50)
FD43-1011-04-04	Female	-04	1/4	1/4	1/4-18	Male Pipe	2	57.9	(2.28)	22.4	(0.88)	19.0	(0.75)
FD40-1014-04-04	Male	-04	1/4	1/4	1/4-18	Male Pipe	4	42.9	(1.69)	-	-	14.2	(0.56)
FD43-1011-06-04	Female	-04	1/4	3/8	3/8-18	Male Pipe	2	59.4	(2.34)	22.4	(0.88)	19.0	(0.75)
FD40-1014-06-04	Male	-04	1/4	3/8	3/8-18	Male Pipe	4	44.4	(1.75)	-	-	17.5	(0.69)
FD40-1014-04-06	Male	-06	3/8	1/4	1/4-18	Male Pipe	4	47.8	(1.88)	-	-	15.7	(0.62)
FD43-1011-06-06	Female	-06	3/8	3/8	3/8-18	Male Pipe	2	62.0	(2.44)	26.9	(1.06)	22.4	(0.88)
FD40-1014-06-06	Male	-06	3/8	3/8	3/8-18	Male Pipe	4	47.8	(1.88)	-	-	17.5	(0.69)
FD40-1014-08-06	Male	-06	3/8	1/2	1/2-14	Male Pipe	4	54.1	(2.13)	-	-	22.4	(0.88)
FD43-1011-08-08	Female	-08	1/2	1/2	1/2-14	Male Pipe	2	78.5	(3.09)	30.2	(1.19)	25.4	(1.00)
FD40-1014-08-08	Male	-08	1/2	1/2	1/2-14	Male Pipe	4	62.0	(2.44)	-	-	22.4	(0.88)
FD40-1014-06-08	Male	-08	1/2	3/8	3/8-18	Male Pipe	4	55.4	(2.18)	-	-	17.5	(0.69)

Dimensions — SOCKETLESS™ Hose Barb

Part Number	Coupling Type	Coupling Size	Body Size	Hose I.D.	Fig.	Dimensions					
						A		B		Hex ①	
						mm	(in)	mm	(in)	mm	(in)
FD43-1031-04-04	Female	-04	1/4	1/4	5	70.6	(2.78)	22.4	(.88)	19.0	(.75)

EATON	HANSEN	FASTER	STUCCHI	PARKER	PERFECTING	SAFEMAY	SNAP-TITE	TOMCO
FD40-1054-04-04	3000	-	-	B33	2DF2-B	S825-2	-	184
FD40-1054-06-04	3200	-	-	B33E	2DF3-B	-	-	185
FD40-1054-04-06	4000	-	-	B35C	3DF2-B	-	-	T4000
FD40-1054-06-06	4200	-	-	B35	3DF3-B	S825-3	-	T4200
FD40-1054-08-08	5200	-	-	B37	4DF4-B	-	-	T5200
FD40-1055-04-04	3100	-	-	B32	2DM2-B	S825-2M	-	181
FD40-1055-06-04	3300	-	-	B32E	2DM3-B	-	-	182
FD40-1055-06-06	4300	-	-	B34	3DM3-B	S825-3M	-	T4300
FD40-1055-08-08	5300	-	-	B36	4DM4-B	-	-	T5300
FD40-1013-02-04	13	-	-	H1C	D2F1	-	-	1803
FD40-1013-04-04	11	-	-	H3C	D2F2	S821-2F	-	1805
FD40-1013-06-04	15	-	-	H3CE	D2F3	-	-	1807
FD40-1013-06-06	43	-	-	H3E	D3F3	S821-3F	-	T43
FD40-1013-08-08	55	-	-	H3F	D4F4	-	-	T55
FD40-1014-02-04	12	-	-	H0C	D2M1	-	-	1802
FD40-1014-04-04	10	-	-	H2C	D2M2	S821-2M	-	1804
FD40-1014-06-04	14	-	-	H2C-E	D2M3	-	-	1806
FD40-1014-04-06	40	-	-	H0E	D3M2	S821-3-2M	-	T40
FD40-1014-06-06	42	-	-	H2E	D3M3	S821-3M	-	T42
FD40-1014-08-06	44	-	-	H2E-F	D3M4	-	-	T44
FD40-1014-06-08	52	-	-	H0F	D4M3	-	-	T52
FD40-1014-08-08	54	-	-	H2F	D4M4	-	-	T54
FD41-1000-02-04	-	-	-	-	-	-	-	103
FD41-1000-04-04	210	-	-	HA-251-4FP	2MF2	S805-2	-	100
FD41-1000-06-04	-	-	-	-	-	-	-	106
FD41-1013-04-04	2609	-	-	A3C	M2F2	S801-2F	-	300
FD41-1014-04-04	2608	-	-	A2C	M2M2	S801-2M	-	200
FD43-1001-04-04	1000	-	-	B23	2FF2-B	S825-2	-	M184
FD43-1001-06-04	1200	-	-	B23E	2FF3-B	-	-	M185
FD43-1001-06-06	420	-	-	25	3FF3	S825-3	-	T420
FD43-1001-08-08	520	-	-	17	4FF4	-	-	T520
FD43-1011-04-04	1100	-	-	B22	2FM2-B	S825-2M	-	M181
FD43-1011-06-06	430	-	-	24	3FM3	S825-3M	-	T430
FD43-1011-08-08	530	-	-	16	4FM4	-	-	T530
FD43-1031-04-04	1600P	-	-	B20-3BP	2FB2-B	-	-	-
FD35-1002-06-06	UPT0P-37F	-	-	TC-372	-	-	-	-
FD35-1001-06-06	UPT0S-37F	-	-	TC-371	-	-	-	-
FD35-1000-06-06	-	-	-	-	-	-	-	-
FD35-1008-06-06	-	-	-	-	-	-	-	-
FD35-1007-06-06	-	-	-	-	-	-	-	-
FD35-1006-06-06	-	-	-	-	-	-	-	-
FD35-1043-06-06	-	-	-	-	-	-	-	-

EATON	HANSEN	FASTER	STUCCHI	PARKER	PERFECTING	SAFEWAY	SNAP-TITE	TOMCO
FD35-1044-06-06								
FD35-1042-06	P-PDC-2-HK/P-SDC-2-HK			TR-37				
FD42-1002-04-04		NV-14-NPT-F	800101001	4010-2P	R2F2-PV	S41-2P	60N4-4F	P2-16
FD42-1001-04-04		NV-14-NPT-F	800101000	4050-2P	2R2F-PV	S25A-2P	60C4-4F	C2-16
FD42-1000-04-04						S20A-2P		
FD42-1010-06-04		NV-14-38SAE-M	80104001	4010-T6				
FD42-1008-06-04		NV-14-38SAE-F	800104000	4050-T6				
FD42-1006-06-04								
FD45-1002-02-02	1-K11	HNV-18-NPT-M	800601001	H1-63	H1F1	S101-1	72N2-2F	TK1-11
FD45-1002-04-04	2-K16	HNV-14-NPT-M	800601003	H2-63	H2F2	S101-2	72N4-4F	TK2-16
FD45-1002-06-06	3-K21	HNV-38-NPT-M	800601005	H3-63	H3F3	S101-3	72N6-6F	TK3-21
FD45-1002-08-10	4-KP26	HNV-12-NPT-M	800601007	H4-63	H4F4	S101-4	72N8-8F	TK4-26
FD45-1002-12-12	6-KP31	HNV-34-NPT-M	800601009	H6-63	H6F6	S101-6	72N12-12F	TK6-31
FD45-1002-16-16	8-KP36	HNV-1-NPT-M	800601011	H8-63	H8F8	S101-8	72N16-16F	TK8-36
FD45-1003-02-02	1-H11	HNV-18-NPT-F	800601000	H1-62	H1F1	S105-1	72C2-2F	TH1-11
FD45-1003-04-04	2-H16	HNV-14-NPT-F	800601002	H2-62	2HF2	S105-2	72C4-4F	TH2-16
FD45-1003-06-06	3-H21	HNV-38-NPT-F	800601004	H3-62	3HF3	S105-3	72C6-6F	TH3-21
FD45-1003-08-10	4-HP26	HNV-12-NPT-F	800601006	H4-62	4HF4	S105-4	72C8-8F	TH4-26
FD45-1003-12-12	6-HP31	HNV-34-NPT-F	800601008	H6-62	6HF6	S105-6	72C12-12F	TH6-31
FD45-1003-16-16	8-HP36	HNV-1-NPT-F	800601010	H8-62	8HF8	S105-8	72C16-16F	TH8-36
FD45-1415-06-04	2-K6	HNV-14-38SAE-M	800604201	H2-63-T6	H2OF3	S101-2-6	72N4-6EF	
FD45-1168-08-06	3-K8			H3-63-T8	H3OF4	S101-3-8	72N6-8EF	
FD45-1168-16-16	8-KP16	HNV-1-1SAE-M		H8-63-T16	H8OF8	S101-8-16	72N16-16EF	
FD45-1414-06-04	2-H6	HNV-14-38SAE-F	800604202	H2-62-T6	2HOF3	S105-2-6	72C4-6EF	
FD45-1169-08-06	3-H8			H3-62-T8	3HOF4	S105-3-8	72C6-8EF	
FD45-1169-16-16	8-HP16	HNV-1-1SAE-F		H8-62-T16	8HOF8	S105-8-16	72C16-16EF	
FD45-1040-02	P-PDC-1-HK	TFH-18		H1-66M	H1-DC	S19-1	72PDC-2	TK1D
FD45-1040-04	P-PDC-2-HK	TFH-14	815000033	H2-66M	H2-DC	S19-2	72PDC-4	TK2D
FD45-1040-06	P-PDC-3-HK	TFH-38	815000035	H3-66M	H3-DC	S19-3	72PDC-6	TK3D
FD45-1040-10	P-PDC-4-HK	TFH-12	815000037	H4-66M	H4-DC	S19-4	72PDC-8	TK4D
FD45-1040-12	P-PDC-6-HK	TFH-34	815000039	H6-66M	H6-DC	S19-6	72PDC-12	TK6D
FD45-1040-16	P-PDC-8-HK	TFH-1	815000041	H8-66M	H8-DC	S19-8	72PDC-16	TK8D
FD45-1041-02	P-SDC-1-HK	TMH-18		H1-65M	H1-DP	S14-1	72PDP-2	TH1D
FD45-1041-04	P-SDC-2-HK	TMH-14	815000032	H2-65M	2H-DP	S14-2	72PDP-4	TH2D
FD45-1041-06	P-SDC-3-HK	TMH-38	815000034	H3-65M	3H-DP	S14-3	72PDP-6	TH3D
FD45-1041-10	P-SDC-4-HK	TMH-12	815000036	H4-65M	4H-DP	S14-4	72PDP-8	TH4D
FD45-1041-12	P-SDC-6-HK	TMH-34	815000038	H6-65M	6H-DP	S14-6	72PDP-12	TH6D
FD45-1041-16	P-SDC-8-HK	TMH-1	815000040	H8-65M	8H-DP	S14-8	72PDP-16	TH8D
FD45-1086-02-02	B1-K11	HNV-18-NPT-M5	804501101	BH1-61	H1F1-B	BS101-1	B72N2-2F	TK1-11-002
FD45-1086-04-04	B2-K16	HNV-14-NPT-M5	804501103	BH2-61	H2F2-B	BS101-2	B72N4-4F	TK2-16-002
FD45-1086-06-06	B3-K21	HNV-38-NPT-M5	804501105	BH3-61	H3F3-B	BS101-3	B72N6-6F	TK3-21-002
FD45-1086-08-10	B4-KP26	HNV-12-NPT-M5	804501107	BH4-61	H4F4-B	BS101-4	B72N8-8F	TK4-26-002

EATON	HANSEN	FASTER	STUCCHI	PARKER	PERFECTING	SAFEWAY	SNAP-TITE	TOMCO
FD45-1086-12-12	B6-KP31	HNV-34-NPT-M5	804501109	BH6-61	H6F6-B	BS101-6	B72N12-12F	TK6-31-002
FD45-1086-16-16	B8-KP36	HNV-1-NPT-M5	804501111	BH8-61	H8F8-B	BS101-8	B72N16-16F	TK8-36-002
FD45-1086-20-20	B10-K41				H10F10-B			
FD45-1101-02-02	B1-H11	HNV-18-NPT-F5	804501100	BH1-60	H1F1-B	BS105-1	B72C2-2F	TH1-11-002
FD45-1101-04-04	B2-H16	HNV-14-NPT-F5	804501102	BH2-60	2HF2-B	BS105-2	B72C4-4F	TH2-16-002
FD45-1101-06-06	B3-H21	HNV-38-NPT-F5	804501104	BH3-60	3HF3-B	BS105-3	B72C6-6F	TH3-21-002
FD45-1101-08-10	B4-HP26	HNV-12-NPT-F5	804501106	BH4-60	4HF4-B	BS105-4	B72C8-8F	TH4-26-002
FD45-1101-12-12	B6-HP31	HNV-34-NPT-F5	804501108	BH6-60	6HF6-B	BS105-6	B72C12-12F	TH6-31-002
FD45-1101-16-16	B8-HP36	HNV-1-NPT-F5	804501110	BH8-60	8HF8-B	BS105-8	B72C16-16F	TH8-36-002
FD45-1101-20-20	B10-H41				H10HF10-B			
FD45-1004-04-04	LL2-K16	HNV-14-NPT-M2	804601103	SH2-63	H2F2-S	SS101-2	S72N4-4F	TK2-16-303
FD45-1004-06-06	LL3-K21	HNV-38-NPT-M2	804601105	SH3-63	H3F3-S	SS101-3	S72N6-6F	TK3-21-303
FD45-1004-08-10	LL4-KP26	HNV-12-NPT-M2	804601107	SH4-63	H4F4-S	SS101-4	S72N8-8F	TK4-26-303
FD45-1004-12-12	LL6-KP31	HNV-34-NPT-M2	804601109	SH6-63	H6F6-S	SS101-6	S72N12-12F	TK6-31-303
FD45-1004-16-16	LL8-KP36	HNV-1-NPT-M2	804601111	SH8-63	H8F8-S	SS101-8	S72N16-16F	TK8-36-303
FD45-1005-04-04	LL2-H16	HNV-14-NPT-F2	804601102	SH2-62	2HF2-S	SS105-2	S72C4-4F	TH2-16-303
FD45-1005-06-06	LL3-H21	HNV-38-NPT-F2	804601104	SH3-62	3HF3-S	SS105-3	S72C6-6F	TH3-21-303
FD45-1005-08-10	LL4-HP26	HNV-12-NPT-F2	804601106	SH4-62	4HF4-S	SS105-4	S72C8-8F	TH4-26-303
FD45-1005-12-12	LL6-HP31	HNV-34-NPT-F2	804601108	SH6-62	6HF6-S	SS105-6	S72C12-12F	TH6-31-303
FD45-1005-16-16	LL8-HP36	HNV-1-NPT-F2	804601110	SH8-62	8HF8-S	SS105-8	S72C16-16F	TH8-36-303
FD48-1002-04-04				SM-252-4FP		SH21-2P		
FD48-1001-04-04				SM-251-4FP		SH25-2P		
FD49-1002-06-06	10FFP37	2FFN38-NPT-M	801301005	FF-372-6FP	HT3F3		74N6-6F	EP3-21
FD49-1002-08-06	10FFP50	2FFN38-12-NPT-M	801301007	FF-372-8FP	HT3F4		74N6-8F	EP3-26
FD49-1004-06-06	10FFP86UN		801304005		HT3OF3		74N6-6EF	
FD49-1004-08-06	10FFP75UN	2FFN38-12SAE-M	801304007	FF-372-8FO	HT3OF4		74N6-8EF	EP3-8
FD49-1057-06-06	10FFP56ORM		801304037				74N6-6EM	
FD49-1057-08-06	10FFP75ORM	2FFN38-1/12S-M	801304033		HT3OM4		74N6-8EM	
FD49-1001-06-06	10FFS37	2FFN38-NPT-F	801301006	FF-371-6FP	3HTF3		74C6-6F	EC3-21
FD49-1001-08-06	10FFS50	2FFN38-12-NPT-F	801301008	FF-371-8FP	3HTF4		74C6-8F	EC3-26
FD49-1005-08-06	10FFS75UN	2FFN38-12SAE-F	801304008	FF-371-8FO	3HTOF4		74C6-8EF	EC3-8
FD49-1014-06-06	10FFS56ORM		803704004				74C6-6EM	
FD49-1014-08-06	10FFS75ORM	2FFN38-1/12S-F	803704006		3HTOM4		74C6-8EM	
FD49-1042-06	PDC10FF/SDC10FF	TMF38/TF-F38	815100002/815100003	NR-50/NR-37	3HTD/HT3DC		74PCC-6/74PNC-6	FP3DC/5606DC
5100-S2-4B								
5100-S2-6B								
5100-S2-8B								
5100-S2-10B				6105-08	W6F4-B			51P-8
5100-S2-12B	96-P31	FB12/34NPT-M5	100610112	6105-12	W6F6-B			51P-12
5100-S2-16B	96-P36	FB16/1NPT-M5	100610116	6105-16	W8F8-B			51P-16
5100-S2-20B	96-P41	FB20/14NPT-M5	100610120	6105-20	W10F10-B			51P-20
5100-S2-24B		FB24*12NPT-M5	100610124	6105-24	W12F12-B			

EATON	HANSEN	FASTER	STUCCCHI	PARKER	PERFECTING	SAFEWAY	SNAP-TITE	TOMCO
5100-S4-4B	-	-	-	-	-	-	-	-
5100-S4-6B	-	-	-	-	-	-	-	-
5100-S4-8B	-	-	-	-	-	-	-	-
5100-S4-10B	-	-	-	6115-08	W6F4-B-BMF	-	-	51PF-8
5100-S4-12B	-	-	-	6115-12	W6F6-B-BMF	-	B78N12-12FWF	51PF-12
5100-S4-16B	-	-	-	6115-16	W8F8-B-BMF	-	B78N16-16FWF	51PF-16
5100-S4-20B	-	-	-	6115-20	W10F10-B-BMF	-	B78N20-20FWF	51PF-20
5100-S4-24B	-	-	-	6115-24	W12F12-B-BMF	-	B78N24-24FWF	-
5100-S5-4B	-	-	-	-	-	-	-	-
5100-S5-6B	-	-	-	-	-	-	-	-
5100-S5-8B	-	-	-	-	-	-	-	-
5100-S5-10B	-	-	-	6125-08	6WF4-B	-	-	51W-8
5100-S5-12B	96-S31	FB12/34NPT-F5	100610012	6125-12	6WF6-B	S515W-6	B78C12-12F	51W-12
5100-S5-16B	96-S36	FB16/1NPT-F5	100610016	6125-16	8WF8-B	S515W-8	B78C16-16F	51W-16
5100-S5-20B	96-S41	FB20/14NPT-F5	100610020	6125-20	10WF10-B	S515W-10	B78C20-20F	51W-20
5100-S5-24B	-	FB24/12NPT-F5	100610024	6125-24	12WF12-B	-	B78C24-24F	-
5110-S5-4B	-	-	-	-	-	-	-	-
5110-S5-6B	-	-	-	-	-	-	-	-
5110-S5-8B	-	-	-	-	-	-	-	-
5110-S5-10B	-	-	-	-	-	-	-	-
5110-S5-12B	-	-	-	6135-08	6WF4-B-HN	-	-	51H-8
5110-S5-16B	-	-	-	6135-12	6WF6-B-HN	S515H-6	B78HC12-12F	51H-12
5110-S5-20B	-	-	-	6135-16	8WF8-B-HN	S515H-8	B78HC16-16F	51H-16
5110-S5-20B	-	-	-	6135-20	10WF10-B-HN	S515H-10	B78HC20-20F	51H-20
5110-S5-24B	-	-	-	6135-24	12WF12-B-HN	-	B78HC24-24F	-
5101-4B	-	-	-	-	-	-	-	-
5101-6B	-	-	-	-	-	-	-	-
5101-8B	-	-	-	-	-	-	-	-
5101-10B	-	-	-	6120-08	-	-	-	-
5101-12B	-	-	-	6120-12	-	S51W-6	-	-
5101-16B	-	-	-	6120-16	-	S51W-8	-	-
5101-20B	-	-	-	6120-20	-	S51W-10	-	-
5101-24B	-	-	-	6120-24	-	-	-	-
5100-4B	-	-	-	-	-	-	-	-
5100-6B	-	-	-	-	-	-	-	-
5100-8B	-	-	-	-	-	-	-	-
5100-10B	-	-	-	6100-08	-	-	-	-
5100-12B	-	-	-	6100-12	-	-	-	-
5100-16B	-	-	-	6100-16	-	-	-	-
5100-20B	-	-	-	6100-20	-	-	-	-
5100-24B	-	-	-	6100-24	-	-	-	-
5111-4B	-	-	-	-	-	-	-	-
5111-6B	-	-	-	-	-	-	-	-

EATON	HANSEN	FASTER	STUCCCHI	PARKER	PERFECTING	SAFEWAY	SNAP-TITE	TOMCO
5111-8B	-	-	-	-	-	-	-	-
5111-10B	-	-	-	6130-08	-	-	-	-
5111-12B	-	-	-	6130-12	-	S51H-6	-	-
5111-16B	-	-	-	6130-16	-	S51H-8	-	-
5111-20B	-	-	-	6130-20	-	S51H-10	-	-
5111-24B	-	-	-	6130-24	-	-	-	-
5110-4B	-	-	-	-	-	-	-	-
5110-6B	-	-	-	-	-	-	-	-
5110-8B	-	-	-	-	-	-	-	-
5110-10B	-	-	-	6110-08	-	-	-	-
5110-12B	-	-	-	6110-12	-	-	-	-
5110-16B	-	-	-	6110-16	-	-	-	-
5110-20B	-	-	-	6100-20	-	-	-	-
5110-24B	-	-	-	6110-24	-	-	-	-
5100-S7-5	-	-	-	-	-	-	-	-
5100-S7-8	-	-	-	-	-	-	-	-
5100-S7-12	PDC-96-075	TFFB12-5	200610112	6108-08	W6DC-B	-	78DC-12	51DC-12
5100-S7-16	PDC-96-100	TFFB16-5	200610116	6108-16	W8DC-B	-	78DC-16	51DC-16
5100-S7-20	PDC-96-125	TFFB20-5	200610120	6108-20	W10DC-B	-	78DC-20	51DC-20
5100-S7-24	-	TFFB24-5	200610124	6108-24	W12DC-B	-	78DC-24	-
5100-S9-5	-	-	-	-	-	-	-	-
5100-S9-8	-	-	-	-	-	-	-	-
5100-S9-12	SDC-96-075	TMFB12-5	200610012	6109-08	6WDP-B	-	78DP-12	51DP-12
5100-S9-16	SDC-96-100	TMFB16-5	200610016	6109-16	8WDP-B	-	78DP-16	51DP-16
5100-S9-20	SDC-96-125	TMFB20-5	200610020	6109-20	10WDP-B	-	78DP-20	51DP-20
5100-S9-24	-	TMFB24-5	200610024	6109-24	12WDP-B	-	78DP-24	-
150-22-5	-	-	-	-	-	-	-	-
150-22-8	-	-	-	-	-	-	-	-
150-22-12	FL96-075	-	-	6107-08	W6-BMF	S512-6	78F-12	51F-12
150-22-16	FL96-100	-	-	6107-16	W8-BMF	S512-8	78F-16	51F-16
150-22-20	FL96-125	-	-	6107-20	W10-BMF	S512-10	78F-20	51F-20
5100-22-24S	-	-	-	6107-24	W12-BMF	-	78F-24	-
5602-2-4S	-	-	-	6602-2-4	K2F1	-	-	-
5602-4-4S	HA-15212-00	ANV-14-NPT-M	800501001	6602-4-4	K2F2	S561-2	61N4-4F	PA5602-16
5602-6-6S	HA-15222-00	ANV-38-NPT-M	800501003	6602-6-6	K3F3	S561-3	61N6-6F	PA5603-21
5602-8-10S	HA-15232-00	NV-12-NPT-M	800501005	6602-8-10	K4F4	S561-4	61N8-8F	PA5604-26
5602-12-10S	-	-	-	6602-12-10	K4F6	-	61N8-12F	PA5604-31
5602-12-12S	HA-15242-00	ANV-34-NPT-M	800501007	6602-12-12	K6F6	S561-6	61N12-12F	PA5606-31
5602-16-16S	HA-15252-00	ANV-1-NPT-M	800501009	6602-16-16	K8F8	S561-8	61N16-16F	PA5608-36
5601-2-4S	-	-	-	6601-2-4	2KF1	-	-	-
5601-4-4S	HA-15211-00	ANV-14-NPT-F	800501000	6601-4-4	2KF2	S565-2	61C4-4F	CA5602-16
5601-6-6S	HA-15221-00	ANV-38-NPT-F	800501002	6601-6-6	3KF3	S565-3	61C6-6F	CA5603-21

EATON	HANSEN	FASTER	STUCCHI	PARKER	PERFECTING	SAFEWAY	SNAP-TITE	TOMCO
5601-8-10S	HA-15231-00	NV-12-NPT-F	800501004	6601-8-10	4KF4	S565-4	61C8-8F	CA5604-26
5601-12-10S	--	--	--	6601-12-10	4KF6	--	61C8-12F	CA5604-31
5601-12-12S	HA-15241-00	ANV-34-NPT-F	800501006	6601-12-12	6KF6	S565-6	61C12-12F	CA5606-31
5601-16-16S	HA-15251-00	ANV-1-NPT-F	800501008	6601-16-16	8KF8	S565-8	61C16-16F	CA5608-36
5610-4-4S	--	--	--	--	--	--	--	--
5610-6-6S	--	ANV-38-38SAE-M	--	6610-6-6	K3OF3	S561-3-6	--	--
5610-8-10S	--	NV-12-12SAE-M	--	6610-8-10	K4OF4	S561-4-8	61N8-8EF	PA5604-8
5610-10-10S	--	NV-12-58SAE-M	--	6610-10-10	K4OF5	S561-4-10	61N8-10EF	PA5604-10
5610-12-10S	--	--	--	6610-12-10	--	--	--	--
5610-12-12S	--	ANV-34-34SAE-M	--	6610-12-12	K6OF6	S561-6-12	61N12-12EF	--
5610-16-16S	--	ANV-1-1SAE-M	--	6610-16-16	K8OF8	S561-8-16	61N16-16EF	--
5608-4-4S	--	--	--	--	--	--	--	--
5608-6-6S	--	ANV-38-38SAE-F	--	6608-6-6	3KOF3	S565-3-6	--	--
5608-8-10S	--	NV-12-12SAE-F	--	6608-8-10	4KOF4	S565-4-8	61C8-8EF	CA5604-8
5608-10-10S	--	NV-12-58SAE-F	--	6608-10-10	4KOF5	S565-4-10	61C8-10EF	CA5604-10
5608-12-10S	--	--	--	6608-12-10	--	--	--	--
5608-12-12S	--	ANV-34-34SAE-F	--	6608-12-12	6KOF6	S565-6-12	61C12-12EF	--
5608-16-16S	--	ANV-1-1SAE-F	--	6608-16-16	8KOF8	S565-8-16	61C16-16EF	--
G5623-4-4	HA-15011-00	ANV-14-GAS-M	--	--	K2BF2	--	61N4-4RP	--
G5623-6-6	HA-15021-00	ANV-38-GAS-M	--	--	K3BF3	--	61N6-6RP	--
G5623-8-10	HA-15031-00	NV-12-GAS-M	--	--	K4BF4	--	61N8-8RP	--
G5623-12-12	HA-15041-00	ANV-34-GAS-M	--	--	K6BF6	--	61N12-12RP	--
G5623-16-16	HA-15051-00	ANV-1-GAS-M	--	--	K8BF8	--	61N16-16RP	--
G5622-4-4	HA-15012-00	ANV-14-GAS-F	--	--	2KBF2	--	61C4-4RP	--
G5622-6-6	HA-15022-00	ANV-38-GAS-F	--	--	3KBF3	--	61C6-6RP	--
G5622-8-10	HA-15032-00	NV-12-GAS-F	--	--	4KBF4	--	61C8-8RP	--
G5622-12-12	HA-15042-00	ANV-34-GAS-F	--	--	6KBF6	--	61C12-12RP	--
G5622-16-16	HA-15052-00	ANV-1-GAS-F	--	--	8KBF8	--	61C16-16RP	--
5657-4	HP-15112-00	TFA-14	815000013	H1-66M	K2DC	S59-2	61PDC-4	5602DC
5657-6	HP-15122-00	TFA-38	815000015	TR-37	K3DC	S59-3	PDC-8	5603DC
5657-10	HP-15132-00	TF-12-G	815000005	5209-4M	K4DC	S59-4	PDC-12	5604DC
5657-12	HP-15142-00	TFA-34	815000017	6657-12M	K6DC	S59-6	61PDC-12	5606DC
5657-16	HP-15152-00	TFA-1	815000019	6657-16M	K8DC	S59-8	61PDC-16	5608DC
5659-4	HP-15111-00	TMA-14	915000012	H1-65M	2KDP	S54-2	61PDP-4	5602DP
5659-6	HP-15121-00	TMA-38	815000014	TR-37	3KDP	S54-3	PDP-8	5603DP
5659-10	HP-15131-00	TM-12L-G	815000004	5205-4M	4KDP	S54-4	61PDP-8	5604DP
5659-12	HP-15141-00	TMA-34	815000016	6659-12M	6KDP	S54-6	61PDP-12	5606DP
5659-16	HP-15151-00	TMA-1	815000018	6659-16M	8KDP	S54-8	61PDP-16	5608DP
FD69-1002-06-08	--	--	--	--	EA4F3	--	56N8-6F	--
FD69-1002-08-08	--	--	--	WB-502-8FP	EA4F4	--	56N8-8F	--
FD69-1012-08-08	--	--	--	--	--	--	--	--
FD69-1001-06-08	--	--	--	--	4EAF3	--	56C8-6F	--

EATON	HANSEN	FASTER	STUCCHI	PARKER	PERFECTING	SAFEWAY	SNAP-TITE	TOMCO
FD69-1001-08-08	--	--	--	WB-501-8FP	4EAF4	--	56C8-8F	--
FD69-1011-08-08	--	--	--	--	--	--	--	--
FD72-1001-08-10	--	--	800401004	8250-4	4AGF4-PV-PS	S45-4P	61DC8-8F	C4-26
FD76-1002-08-10	--	--	800501005	8010-4P	AG4F4-PV	S71-4P	63N8-8F	P4-26
FD76-1010-08-10	--	--	--	8010-15P	AG4OF4-PV	S71-15P	63N8-8EF	P4-8
FD89-1002-04-04	6FFP25	2FF114-NPT-M	800801001	FEM-252-4FP	HT2F2	FFE491-2	74N4-4F	EP2-16
FD89-1002-06-06	10FFP37	2FFN38-NPT-M	800801005	FEM-372-6FP	HT3F3	--	74N6-6F	EP3-21
FD89-1002-08-06	10FFP50	2FFN38-12NPT-M	800801003	--	HT3F4	--	74N6-8F	EP3-26
FD89-1002-08-08	12FFP50	2FF112-NPT-M	800801007	FEM-502-8FP	HT4F4	FFE491-4	74N8-8F	EP4-26
FD89-1002-12-08	12FFP75	2FF112-34-NPT-M	800801009	--	HT4F6	FFE491-4-3/4	74N8-12F	EP4-31
FD89-1002-12-12	16FFP75	FFI68-34N-M	800801011	--	HT5F6	--	74N10-12F	--
FD89-1002-16-16	19FFP100	FFI34-1-NPT-M	800801013	--	HT6F8	FFE491-6-1	74N12-16F	--
FD89-1002-20-20	25FFP125	--	800801015	--	HT8F10	FFE491-8-114	74N16-20F	--
FD89-1002-24-24	--	FFI112-NPT-M	--	--	--	--	--	--
FD89-1002-32-32	--	FFI2-NPT-M	--	--	--	--	--	--
FD89-1001-04-04	6FFS25	2FF114-NPT-F	800801000	FEM-251-4FP-NL	2HTF2	FFE495-2	74C4-4F	EC2-16
FD89-1001-06-06	10FFS37	2FFN38-NPT-F	800801004	FEM-371-6FP-NL	3HTF3	--	74C6-6F	EC3-21
FD89-1001-08-06	10FFS50	2FFN38-12-NPT-F	800801002	--	3HTF4	--	74C6-8F	EC3-26
FD89-1001-08-08	12FFS50	2FF112-NPT-F	800801006	FEM-501-8FP-NL	4HTF4	FFE495-4	74C8-8F	EC4-26
FD89-1001-12-08	12FFS75	2FF112-34-NPT-F	800801008	--	4HTF6	FFE495-4-3/4	74C8-12F	EC4-31
FD89-1001-12-12	16FFS75	2FFI58-34N-F	800801010	--	5HTF6	--	74C10-12F	--
FD89-1001-16-16	19FFS100	2FFI34-1-NPT-F	800801012	--	6HTF8	FFE495-6-1	74C12-16F	--
FD89-1001-20-20	25FFS125	--	800801014	--	8HTF10	FFE495-8-114	74C16-20F	--
FD89-1001-24-24	--	2FFS112-NPT-F	--	--	--	--	--	--
FD89-1001-32-32	--	2FFS12-NPT-F	--	--	--	--	--	--
FD89-1007-04-04	6FFP25B5	2FF114-GAS-M	800800001	--	HT2B2	--	74N4-4RP	--
FD89-1007-06-06	10FFP37B5	2FFN38-GAS-M	800800005	--	HT3B3	--	74N6-6RP	--
FD89-1007-08-06	10FFP50B5	2FFN38-12-GAS-M	800800003	--	HT3B4	--	74N6-8RP	--
FD89-1007-08-08	12FFP50B5	2FF112-GAS-M	800800007	--	HT4B4	--	74N8-8RP	--
FD89-1007-12-08	12FFP75B5	2FFA12-34-GAS-M	800800009	--	HT4B6	--	74N8-12RP	--
FD89-1007-12-12	16FFP75B5	FFI58-34GAS-M	800800011	--	HT5B6	--	74N10-12RP	--
FD89-1007-16-16	19FFP100B5	FFI34-1-GAS-M	800800013	--	HT6B8	--	74N12-16RP	--
FD89-1007-20-20	25FFP125B5	FFI114-G-M	800800015	--	HT8B10	--	74N16-20RP	--
FD89-1007-24-24	--	FFI112-GAS-M	801300025	--	--	--	--	--
FD89-1007-32-32	--	FFI2-GAS-M	800800019	--	--	--	--	--
FD89-1006-04-04	6FFS25B5	2FF114-GAS-F	800800000	--	2HTB2	--	74C4-4RP	--
FD89-1006-06-06	10FFS37B5	2FFN38-GAS-F	800800004	--	3HTB3	--	74C6-6RP	--
FD89-1006-08-06	10FFS50B5	2FFN38-12-GAS-F	800800002	--	3HTB4	--	74C6-8RP	--
FD89-1006-08-08	12FFS50B5	2FF112-GAS-F	800800006	--	4HTB4	--	74C8-8RP	--
FD89-1006-12-08	12FFS75B5	2FF112-34-GAS-F	800800008	--	4HTB6	--	74C8-12RP	--
FD89-1006-12-12	16FFS75B5	2FFI58-34-GAS-F	800800010	--	5HTB6	--	74C10-12RP	--
FD89-1006-16-16	19FFS100B5	2FFI34-1-GAS-F	800800012	--	6HTB8	--	74C12-16RP	--

EATON	HANSEN	FASTER	STUCCHI	PARKER	PERFECTING	SAFEMAN	SNAP-TITE	TOMCO
FD89-1006-20-20	25FFS12BBS	-	800800014	-	8HTBF10	-	74C16-20RP	-
FD89-1006-24-24	-	2FS112-GAS-F	800800016	-	-	-	-	-
FD89-1006-32-32	-	2FS12-GAS-F	800800018	-	-	-	-	-
FD89-1004-06-04	6FFP56UN	2FFI14-38SAE-M	800804001	FEM-252-6FO	-	-	74N4-6EF	-
FD89-1004-08-06	10FFP75UN	2FFN38-12SAE-M	800804003	FEM-372-8FO	HT30F4	-	74N6-8EF	EP3-8
FD89-1004-10-06	10FFP87UN	2FFN38-58SAE-M	800804005	-	-	-	74N6-10EF	-
FD89-1004-10-08	12FFP87UN	2FFI12-58SAE-M	800804007	FEM-502-10FO	HT40F5	FFE491-4-10	74N8-10EF	-
FD89-1004-12-08	12FFP106UN	2FFI12-34SAE-M	800804009	FEM-502-12FO	HT40F6	FFE491-4-12	74N8-12EF	EP4-12
FD89-1004-12-12	16FFP106UN	FFI58-34SAE-M	800804011	FEM-622-12FO	HT50F6	-	74N10-12EF	-
FD45-1004-16-16	19FFP131UN	FFI34-1SAE-M	800804013	-	HT60F8	FFE491-6-16	74N12-16EF	-
FD89-1004-20-20	25FFP162UN	-	800804015	-	HT80F10	FFE491-8-20	74N16-20EF	-
FD89-1004-24-24	-	-	-	-	-	-	-	-
FD89-1004-32-32	-	-	-	-	-	-	-	-
FD89-1005-06-04	6FFS56UN	2FFI14-38SAE-F	800804000	FEM-251-6FO-NL	-	-	74C4-6EF	-
FD89-1005-08-06	10FFS75UN	2FFN38-12SAE-F	800804002	FEM-371-8FO-NL	3HTOF4	-	74C6-8EF	EC3-8
FD89-1005-10-06	10FFS87UN	2FFN38-58SAE-F	800804004	-	-	-	74C6-10EF	-
FD89-1005-10-08	12FFS87UN	2FFI12-58SAE-F	800804006	FEM-501-10FO-NL	4HTOF5	FFE495-4-10	74C8-10EF	-
FD89-1005-12-08	12FFS106UN	2FFI12-34SAE-F	800804008	FEM-501-12FO-NL	4HTOF6	FFE495-4-12	74C8-12EF	EC4-12
FD89-1005-12-12	16FFS106UN	2FFI58-34SAE-F	800804010	FEM-621-12FO-NL	5HTOF6	-	74C10-12EF	-
FD89-1005-16-16	19FFS131UN	2FFI34-1SAE-F	800804012	-	6HTOF8	FFE495-6-16	74C12-16EF	-
FD89-1005-20-20	25FFS162UN	-	800804014	-	8HTOF10	FFE495-8-20	74C16-20EF	-
FD89-1005-24-24	-	-	-	-	-	-	-	-
FD89-1005-32-32	-	-	-	-	-	-	-	-
FD89-1009-04	SDC6FF	TM-2FI14	815100000	FR-25	-	-	74PCC-4	-
FD89-1009-06	SDC10FF	TM-F38	815100002	NR-37	3HTDP	-	74PCC-6	5606DSC
FD89-1009-08-08	SDC12FF	TM-2FI12	815100004	FER-502	4HTDP	-	74PCC-8	-
FD89-1009-12-08	SDC12FF	TM-2FI12	815100006	FER-502	4HTDP	-	74PCC-8	-
FD89-1009-12	SDC16FF	TM-2FI58	815100008	-	5HTDP	-	74PCC-10	-
FD89-1009-16	SDC19FF	TM-2FI34	815100010	FER-752	6HTDP	-	74PCC-12	-
FD89-1009-20	SDC25FF	TM-2FI11	815100012	-	8HTDP	-	74PCC-16	-
FD89-1009-24	-	TM-2FI112-S	815100014	-	-	-	-	-
FD89-1009-32	-	TM-2FI2-S	815100016	-	-	-	-	-
FD89-1008-04	PDC6FF	TF-2FI14	815100001	FR-25	-	-	74PNC-4	-
FD89-1008-06-06	PDC10FF	TF-F38	815100003	NR-50	HT3DC	-	74PNC-6	FP3DC
FD89-1008-08-06	PDC10FF	TF-F38	815100005	NR-50	HT3DC	-	74PNC-6	FP3DC
FD89-1008-08-08	PDC12FF	TF-2FI12	815100007	FR-501	HT4DC	-	74PNC-8	-
FD89-1008-12-08	PDC12FF	TF-2FI12	815100009	FR-501	HT4DC	-	74PNC-8	-
FD89-1008-12	PDC16FF	TF-2FI58	815100011	-	HT5DC	-	74PNC-10	-
FD89-1008-16	PDC19FF	TF-2FI34	815100013	FR-751	HT6DC	-	74PNC-12	-
FD89-1008-20	PDC25FF	TF-2FI11	815100015	FR-1001	HT8DC	-	74PNC-16	-
FD89-1008-24	-	TF-2FI112-S	815100017	-	-	-	-	-
FD89-1008-32	-	TF-2FI2-S	815100019	-	-	-	-	-

EATON	HANSEN	FASTER	STUCCHI	PARKER	PERFECTING	SAFEMAN	SNAP-TITE	TOMCO
FD90-1034-02-04	-	DF-04-18NPTM	-	PD322	PD1F1	-	-	KPI-11
FD90-1034-04-04	-	DF-04-14NPTM	-	PD342	PD1F2	-	-	KPI-16
FD90-1035-02-04	-	-	-	PD322.6	-	-	-	-
FD90-1035-04-04	-	-	-	PD342.6	-	-	-	-
FD90-1044-03-04	-	DF-04-1/316SAE-M	-	PD331	-	-	-	-
FD90-1044-04-04	-	DF-04-1/4SAE-M	-	PD341	PD1OM2	-	-	KPI-4
FD90-1044-05-04	-	DF-04-1/516SAE-M	-	PD351	-	-	-	-
FD90-1044-06-04	-	DF-04-1/38SAE-M	-	PD361	PD1OM3	-	-	KPI-6
FD90-1004-03-04	-	-	-	PD331-6	-	-	-	-
FD90-1004-04-04	-	-	-	PD341-6	-	-	-	-
FD90-1004-05-04	-	-	-	PD351-6	-	-	-	-
FD90-1004-06-04	-	-	-	PD361-6	-	-	-	-
FD90-1012-02-04	-	DF-04-1/18NPTM	-	PD323	PD1M1	-	-	KPI-10
FD90-1012-04-04	-	DF-04-1/14NPTM	-	PD343	PD1M2	-	-	KPI-15
FD90-1045-02-04	-	-	-	PD323-6	-	-	-	-
FD90-1045-04-04	-	-	-	PD343-6	-	-	-	-
FD90-1046-06-04	-	DF-04-21/1415-M	-	-	-	-	-	-
FD90-1047-06-04	-	-	-	-	-	-	-	-
FD90-1021-02-04	-	DF-04-18NPT-F	-	PD222	1PDF1	-	-	KC1-11
FD90-1021-04-04	-	DF-04-14NPT-F	-	PD242	1PDF2	-	-	KC1-16
FD90-1041-04-04	-	DF-04-14SAE-F	-	PD240	-	-	-	-
FD90-1206-04-04	-	DF-04-12/14SAE-M	-	PD346	-	-	-	-
FD90-1061-04-04	-	DF-04-35/14SAE-M	-	PD348TL	-	-	-	-
FD90-1061-06-04	-	DF-04-35/38SAE-M	-	PD368TL	-	-	-	-
FD90-1061-08-04	-	DF-04-35/12SAE-M	-	PD388TL	-	-	-	-
FD90-1090-10-04	-	-	-	PD357	-	-	-	-
FD90-1040-04	-	TEDE-04	-	PD6-285	-	-	-	DK1C
FD31-1001-04-04	WA-56517-00	PVVM1/14NPT-F	800201008	3050-2	2TM2	-	76C4-4M	JC2-15
FD31-1001-06-06	WA-56527-00	PVVM1/38NPT-F	800201004	3050-3	3TM3	-	76C6-6M	JC3-20
FD31-1002-04-04	WA-56514-00	PVVM14NPTM	800201009	3010-2	T2F2	-	76N4-4F	JP2-16
FD31-1002-06-06	WA56524-00	PVVM38NPTM	800201005	3010-3	T3F3	-	76N6-6F	JP3-21
FD31-1005-04	WA-56117-00	TMP-14	815605004	3009-2	2TDP	-	76MDP-4	JC2-DCP
FD31-1005-06	WA-56127-00	TMP-38	815605002	3009-3	3TDP	-	76MDP-6	JC3-DCP
FD31-1004-04	WA-56114-00	TFP-14	815605005	3005-2	T2DC	-	76MDC-4	JC2-DCP
FD31-1004-06	WA-56124-00	TFP-38	815605003	3005-3	T3DC	-	76MDC-6	JC3-DCP
FD89-2001-04-04	-	2FFI14-NPT-F2	802401100	-	-	-	-	-
FD89-2001-06-06	3DBS-37F	2FFN38-NPT-F2	802401102	-	3HTF3-SS	SF495-3	-	FC3-21-316
FD89-2001-08-08	-	2FFI12-NPT-F2	802401106	-	4HTF4-SS	-	-	-
FD89-2001-12-10	-	2FFI58-34NPT-F2	802401110	-	5HTF6-SS	-	-	-
FD89-2001-16-12	-	2FFI34-1N-F2	802401112	-	6HTF8-SS	-	-	-
FD89-2001-20-16	-	-	802401114	-	8HTF10-SS	-	-	-
FD89-2001-24-24	-	-	802401116	-	-	-	-	-

EATON	HANSEN	FASTER	STUCCHI	PARKER	PERFECTING	SAFEWAY	SNAP-TITE	TOMCO
FD89-2001-32-32	-	-	802401120	-	-	-	-	-
FD89-2002-04-04	-	FF114-NPT-M2	802401101	-	-	-	-	-
FD89-2002-06-06	3DBP-37F	FFN38-NPT-M2-U	802401103	-	HT3F3-SS	SF491-3	-	FP3-21-316
FD89-2002-08-08	-	FF112-NPT-M2	802401107	-	HT4F4-SS	-	-	-
FD89-2002-12-10	-	FFI58-34N-M2	802401111	-	HT5F6-SS	-	-	-
FD89-2002-16-12	-	FFB4-1N-M2	802401113	-	HT6F8-SS	-	-	-
FD89-2002-20-16	-	-	802401115	-	HT8F10-SS	-	-	-
FD89-2002-24-24	-	-	802401117	-	-	-	-	-
FD89-2002-32-32	-	-	802401121	-	-	-	-	-
FD99-1001-04-04	6FFS25	-	801301004	-	-	-	-	-
FD99-1001-06-06	10FFS37	-	801301006	-	-	-	-	-
FD99-1001-08-06	10FFS50	-	801301008	-	-	-	-	-
FD99-1001-08-08	12FFS50	-	801301010	-	-	-	-	-
FD99-1001-12-08	12FFS75	-	801301012	-	-	-	-	-
FD99-1001-12-10	16FFS75	-	801301014	-	-	-	-	-
FD99-1001-12-12	19FFS75	-	801301030	-	-	-	-	-
FD99-1001-16-12	19FFS100	-	801301000	-	-	-	-	-
FD99-1001-16-16	25FFS100	-	801301028	-	-	-	-	-
FD99-1001-20-16	25FFS125	-	801301016	-	-	-	-	-
FD99-1001-20-20	-	-	801301034	-	-	-	-	-
FD99-1001-24-24	-	-	801301018	-	-	-	-	-
FD99-1002-04-04	6FFP25	-	800801001	-	-	-	-	-
FD99-1002-06-06	10FFP37	-	801301005	-	-	-	-	-
FD99-1002-08-06	10FFP50	-	801301007	-	-	-	-	-
FD99-1002-08-08	12FFP50	-	801301009	-	-	-	-	-
FD99-1002-12-08	12FFP75	-	801301011	-	-	-	-	-
FD99-1002-12-10	16FFP75	-	801301013	-	-	-	-	-
FD99-1002-12-12	19FFP75	-	801301031	-	-	-	-	-
FD99-1002-16-12	19FFP100	-	801301001	-	-	-	-	-
FD99-1002-16-16	25FFP100	-	801301029	-	-	-	-	-
FD99-1002-20-16	25FFP125	-	801301015	-	-	-	-	-
FD99-1002-20-20	-	-	801301035	-	-	-	-	-
FD99-1002-24-24	-	-	801301017	-	-	-	-	-
FD99-1004-06-04	6FFS56UN	-	801304004	-	-	-	-	-
FD99-1004-06-06	10FFS56UN	-	801304006	-	-	-	-	-
FD99-1004-08-06	10FFS75UN	-	801304008	-	-	-	-	-
FD99-1004-08-08	12FFS75UN	-	803304004	-	-	-	-	-
FD99-1004-10-06	10FFS87UN	-	801304030	-	-	-	-	-
FD99-1004-10-08	12FFS87UN	-	801304024	-	-	-	-	-
FD99-1004-12-08	12FFS106UN	-	801304010	-	-	-	-	-
FD99-1004-12-10	16FFS106UN	-	801304012	-	-	-	-	-
FD99-1004-12-12	19FFS106UN	-	801304028	-	-	-	-	-

EATON	HANSEN	FASTER	STUCCHI	PARKER	PERFECTING	SAFEWAY	SNAP-TITE	TOMCO
FD99-1004-16-12	19FFS131UN	-	801304000	-	-	-	-	-
FD99-1004-16-16	-	-	801304038	-	-	-	-	-
FD99-1004-20-16	25FFS162UN	-	801304014	-	-	-	-	-
FD99-1004-20-20	-	-	801304042	-	-	-	-	-
FD99-1004-24-24	-	-	801304016	-	-	-	-	-
FD99-1005-06-04	6FFP56UN	-	800804001	-	-	-	-	-
FD99-1005-06-06	10FFP56UN	-	801304005	-	-	-	-	-
FD99-1005-08-06	10FFP75UN	-	801304007	-	-	-	-	-
FD99-1005-08-08	12FFP75UN	-	801304035	-	-	-	-	-
FD99-1005-10-06	10FFP87UN	-	801304031	-	-	-	-	-
FD99-1005-10-08	12FFP87UN	-	801304025	-	-	-	-	-
FD99-1005-12-08	12FFP106UN	-	801304009	-	-	-	-	-
FD99-1005-12-10	16FFP106UN	-	801304011	-	-	-	-	-
FD99-1005-12-12	19FFP106UN	-	801304029	-	-	-	-	-
FD99-1005-16-12	19FFP131UN	-	801304001	-	-	-	-	-
FD99-1005-16-16	-	-	801304039	-	-	-	-	-
FD99-1005-20-16	25FFP162UN	-	801304013	-	-	-	-	-
FD99-1005-20-20	-	-	801304043	-	-	-	-	-
FD99-1005-24-24	-	-	801304015	-	-	-	-	-

Eaton
Hydraulics Group USA
14615 Lone Oak Road
Eden Prairie, MN 55344
USA
Tel: 952-937-9800
Fax: 952-294-7722
www.eaton.com/hydraulics

Eaton
Hydraulics Group Europe
Route de la Longeraie 7
1110 Morges
Switzerland
Tel: +41 (0) 21 811 4600
Fax: +41 (0) 21 811 4601

Eaton
Hydraulics Group Asia Pacific
Eaton Building
4th Floor, No. 3 Lane 280 Linhong Rd.
Changning District
Shanghai 200335
China
Tel: (+86 21) 5200 0099
Fax: (+86 21) 5200 0400



Powering Business Worldwide

© 2010 Eaton Corporation
All Rights Reserved
Printed in USA
Document No. E-MEQD-MC002-E
June 2010