

EXMAR

Edelstahl Verbindungstechnik
Stainless steel connection technology
Conexiones en acero inoxidable



Sicher verbunden mit...
Reliable connection with...
Conexión segura con...



EXMAR

Vertrauen Sie auf die exzellente Qualität unserer Produkte.

Wir verwenden ausschließlich hochwertigen Edelstahl für die Herstellung unserer Bauteile und arbeiten kontinuierlich an der Neu- und Weiterentwicklung unserer Produkte.

Um Ihnen stets die passende Lösung bieten zu können, optimieren wir unser Produktsortiment für Sie. Schauen Sie in unseren tagesaktuellen Online Shop, den Link dazu finden Sie auf unserer Website www.exmar.de.

Profitieren Sie von unserer technischen Kompetenz, wenn es um Baugruppen oder Rohrsysteme geht.

Rely on the excellent quality of our products.

Besides continuously improving and developing our products we only use the highest quality of stainless steel to manufacture our components.

To be able to offer you the best possible solution we optimise our range of products referring to your needs. Have a look at our Online Shop which is be linked from our website www.exmar.de/en.







Take full benefit of our longstanding technical competence when it comes to assemblies or pipe systems.

Confíe en la extraordinaria calidad de nuestras uniones para tubos rígidos y flexibles.

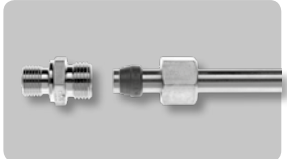
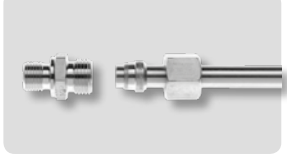
Utilizamos exclusivamente acero inoxidable de alta calidad para la fabricación de nuestros componentes y trabajamos continuamente en la creación de productos nuevos y el desarrollo de los existentes.

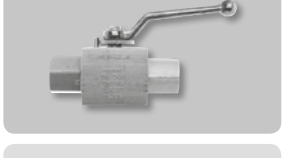
Optimizamos nuestros productos para poder ofrecerle la mejor solución a sus necesidades. Puede ver nuestra tienda Online en el siguiente link: www.exmar.de/en.

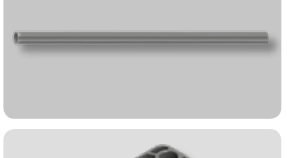
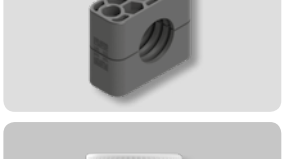
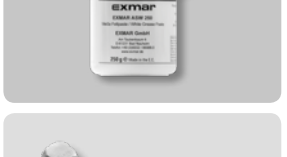
Benefíciense de nuestra larga experiencia técnica para sistemas de tuberías y montajes de conjuntos.

Inhaltsverzeichnis	Index	Indice		
Technische Informationen Montageanleitungen Empfehlungen für Edelstahlrohre	Technical information Assembly instructions Recommendations for stainless steel tubes	Información técnica Instrucciones de montaje Recomendación para tubos de acero inoxidable		i
Schneidringverschraubungen	Cutting Ring Fittings	Racores de anillo cortante		10
NC-Klemmringverschraubungen	NC Clamping Ring Fittings	Racores de anillo de apriete NC		20
Bördel-Rohrverschraubungen	Flared Tube Fittings	Racores rebordeados		30
Adapter	Adaptors	Adaptadores		40
Kugelhähne und Ventile Niederdruck-Kugelhähne Hochdruck-Kugelhähne Rückschlagventile Ventile	Ball Valves and Valves Low pressure ball valves High pressure ball valves Non-return valves Valves	Llaves esféricas y válvulas Llaves esféricas de baja presión Llaves esféricas de alta presión Válvulas de retención Válvulas		50
Schlaucharmaturen	Hose Couplings	Conectores de manguera		60
Rohre und Schläuche	Tubes and Hoses	Tubos y mangueras		70
Rohrschellen	Tube Clamps	Abrazaderas de tubo		80
Zubehör und Werkzeuge	Accessories and Tools	Accesorios y utilajes		90
Dienstleistungen Reinigungen Vorbeschichtete Gewinde Sonderkonstruktionen	Services Cleaning Pre-coated threads Special designs	Servicios Limpiezas Roscas recubiertas Modelos especiales		S
Anhang Technische Erläuterungen Beständigkeitsliste	Appendix Technical instructions Table of chemical resistance	Anexo Instrucciones técnica Lista de constancia química		a

Index EXMAR Typenbezeichnung

Index EXMAR Types

EXMAR Type	Seite Page	EXMAR Type	Seite Page	EXMAR Type	Seite Page	EXMAR Type	Seite Page
AC 1163	90.12	EDKOL/EDKOS	60.17	GEV..SNPT	10.59	NC-GEV..SR	20.16
AC 1164	90.12	EDKOL/EDKOS-45°	60.18	GEV..SNPT	10.61	NC-GEV..SR WD	20.18
AC 832 45°	90.8	EDKOL/EDKOS-90°	60.19	GEV..SR	10.35	NC-GEV..SR WD	20.19
AC 832 45° M	90.9	EDKR	60.14	GEV..SR	10.37	NC-GKO..L	20.7
AC 832 90°	90.6	EDKR..M/R	10.207	GEV..SR WD	10.39	NC-GRKO..L	20.58
AC 832 90° M	90.7	EDKR-45°	60.15	GEV..SR WD	10.41	NC-GRKO..L	20.59
AC 835	90.11	EDKR-90°	60.16	GKO..L	10.11	NC-GRKO..S	20.60
AC 836	90.11	EFT 2257/2	50.48	GRKO..L	10.159	NC-GRKO..S	20.61
AC 840, AC 841	90.15	EFT 2257/5	50.49	GRKO..L	10.161	NC-GR..L	20.62
AC 850	90.15	EF-09	60.5	GRKO..S	10.163	NC-GR..S	20.63
AC 851 OX	90.16	EF-10	60.6	GRKO..S	10.165	NC-GSV..L/S	20.12
AC 86600	90.13	EF-20	60.7	GR..L	10.167	NC-GV..L/S	20.6
AC DLS	90.14	EGKO..LM WD/SM WD	10.90	GR..S	10.169	NC-KV..L/S	20.10
AC DTS	90.16	EGKO..LNPT/SNPT	10.91	GR..S	10.171	NC-LEV..LNPT/SNPT	20.39
AC SPE	90.10	EGKO..LR WD/SR WD	10.89	GSV..L/S	10.23	NC-LEV..LR	20.37
AD A 50 G-NPT	40.13	EKM	50.51	GV..L/S	10.9	NC-LEV..LRK/SRK	20.38
AD A 50 G-R	40.12	ELKO..L/S	10.123	HKM-G	50.16	NC-MAV..LNPT/SNPT	20.56
AD A 50 NPT-NPT	40.15	ELV..LR/SR	10.126	HKM-NPT	50.17	NC-MAV..LR/SR	20.55
AD A 50 NPT-R	40.14	ELV..L/S	10.125	HKS..L/S	50.19	NC-R..L/S	20.69
AD C 50	40.17	EMAKO..LR/SR	10.147	HVMS..L/S	90.18	NC-TEV..LNPT/SNPT	20.36
AD CN 50	40.9	EMAS..LNPT/SNPT	10.151	INOX 1.4301	70.10	NC-TEV..LRK/SRK	20.35
AD CNS 50	40.10	EMAS..LR/SR	10.149	INOX 1.4571	70.9	NC-TEV..LR/SR	20.34
AD CNW 50	40.11	EMV..	10.154	KM..L/S	10.206	NC-TR..L/S	20.64
AD CNW 50 NPT	40.11	EMV..L/S	10.155	KR..L	10.173	NC-TV..L/S	20.9
AD CS 50	40.18	EMV-GV..L/S	10.153	KR..L	10.175	NC-UEM..L/S	20.68
AD FCW 50 NPT	40.20	ERVV..LR WD/SR WD	50.31	KR..S	10.177	NC-VSA..L/S	20.11
AD HC 50	40.19	ERVZ..LR WD/SR WD	50.29	KR..S	10.179	NC-WAS..L/S	20.66
AD HCP 50	40.24	ESA	60.30	KV..L/S	10.19	NC-WEE..LM	20.45
AD HN 50 NPT-NPT	40.8	ESS..LM WD/SM WD	10.99	LDPE-ROHRE	70.13	NC-WEE..LR	20.44
AD HN 50 R	40.7	ESS..LM/SM	10.97	LEV..LNPT/SNPT	10.85	NC-WEV..LMK/SMK	20.31
AD HN 50 R-NPT	40.8	ESS..LNPT/SNPT	10.101	LEV..LR	10.81	NC-WEV..LNPT	20.32
AD HP 50 R	40.23	ESS..LR WD/SR WD	10.95	LEV..LRK/SRK	10.83	NC-WEV..LRK	20.29
AD HRC 50	40.19	ESS..LR/SR	10.93	MAV..LNPT/SNPT	10.145	NC-WEV..LR/SR	20.28
AD SP 50	40.24	ESV..L/S	10.189	MAV..LR/SR	10.143	NC-WEV..SNPT	20.33
ADH A 50	40.16	ESWV..LM WD/SM WD	10.135	MV-R 16270	50.46	NC-WEV..SRK	20.30
ADH HNIC 50	40.6	ESWV..LM/SM	10.133	MV-R 16271	50.47	NC-WSV..L/S	20.13
ASW	90.17	ESWV..LR WD/SR WD	10.131	NC-DRV..L/S	50.32	NC-WV..L/S	20.8
AVD..L/S	50.39	ESWV..LR/SR	10.129	NC-ELKO..L/S	20.47	NKM-G PN 130/100	50.7
AVD-G	50.37	ETKO..L/S	10.117	NC-EMV-GV..L/S	20.57	NKM-G PN 63	50.12
AVI..L/S	50.45	ETV..LR/SR	10.120	NC-ERVV..LR WD/SR WD	50.34	NKM-NPT PN 63	50.13
AVI-G	50.43	ETV..L/S	10.119	NC-ERVZ..LR WD/SR WD	50.33	NKS-PN 130/100	50.9
BO-A..L/S	30.5	EWKO..L 45°	10.103	NC-ESV..L/S	20.67	PA-ROHRE	70.11
BO-DR..L/S	30.7	EWKO..LR WD/SR WD	10.107	NC-ESWV..LM WD/SM WD	20.51	PFA-ROHRE	70.20
BO-M..L/S	30.8	EWKO..LR/SR	10.106	NC-ESWV..LM/SM	20.50	PTFE-KLEMMRING	10.88
BO-ZR..L/S	30.6	EWKO..L/S	10.105	NC-ESWV..LR WD/SR WD	20.49	PTFE-ROHRE	70.16
DKR..R	10.208	EWV..LR/SR	10.110	NC-ESWV..LR/SR	20.48	PU-ROHRE	70.15
DRM..	50.25	EWV..L/S	10.109	NC-ETKO..L/S	20.46	PVDF-ROHRE	70.18
DRV..L/S	50.27	FEP-ROHRE	70.19	NC-EWKO..L 45°	20.40	RK 51900	90.5
EA	40.4	GASK..	10.185	NC-EWKO..LR WD/SR WD	20.43	RS AKZ1A-SB	80.13
EAGF	60.22	GAS..L/S	10.183	NC-EWKO..LR/SR	20.42	RS AKZ2A-E1	80.14
EAGJ	60.26	GAV..LM/SM	10.141	NC-EWKO..L/S	20.41	RS AKZ3B-E1	80.15
EAGK	60.23	GAV..LR	10.137	NC-GAS..L/S	20.65	RS ASA-E1	80.23
EAGN	60.24	GAV..SR	10.139	NC-GAV..LM/SM	20.54	RS DPA-E1	80.17
EAGNF	60.25	GEV..LM	10.43	NC-GAV..LR	20.52	RS DPA-VZ	80.16
EAGR	60.21	GEV..LM WD	10.45	NC-GAV..SR	20.53	RS DPB-E1	80.18
EAR	40.5	GEV..LMK	10.53	NC-GEV..LM	20.20	RS ISA-E1	80.22
EBEL/EBES	60.8	GEV..LNPT	10.55	NC-GEV..LM WD	20.21	RS ISA-VZ	80.21
EBEL/EBES-45°	60.9	GEV..LNPT	10.57	NC-GEV..LMK	20.25	RS RGA PA F	80.8
EBEL/EBES-90°	60.10	GEV..LR	10.27	NC-GEV..LNPT	20.26	RS RGA-AL	80.9
ECEL/ECES	60.20	GEV..LR	10.29	NC-GEV..LR	20.14	RS RGA-PA	80.6
EDKJ	60.27	GEV..LR D	10.87	NC-GEV..LR WD	20.15	RS RGA-PA	80.7
EDKJ-45°	60.28	GEV..LR WD	10.31	NC-GEV..LRK	20.24	RS RGA-PP	80.4
EDKJ-90°	60.29	GEV..LR WD	10.33	NC-GEV..SM	20.22	RS RGA-PP	80.5
EDKL	60.11	GEV..LRK	10.51	NC-GEV..SM WD	20.23	RS RGB-PA	80.11
EDKL-45°	60.12	GEV..SM	10.47	NC-GEV..SNPT	20.27	RS RGB-PA F	80.12
EDKL-90°	60.13	GEV..SM WD	10.49	NC-GEV..SR	20.17	RS RGB-PP	80.10

EXMAR Type	Seite Page	EXMAR Type	Seite Page	EXMAR Type	Seite Page
RS SSA-E1	80.20	XESWV..LM/SM	10.132	XWEV..LR/SR	10.62
RS SSA-VZ	80.19	XESWV..LR WD/SR WD	10.130	XWEV..SNPT	10.72
RS TMA-E1/TMVA-E1	80.26	XESWV..LR/SR	10.128	XWEV..SRK	10.66
RS TMA-VZ/TMVA-VZ	80.25	XETKO..L/S M	10.116	XWSV..L/S KM	10.24
RS TS-E1	80.24	XETV..L/S M	10.118	XWV..L/S	10.14
RS TS-SB	80.24	XEWKO..L M 45°	10.102		
RS..	10.194	XEWKO..L/S M	10.104		
RS..	10.195	XEWV..L/S M	10.108		
RS..WD	10.196	XGASK..	10.184		
RS..WD	10.197	XGAS..L/S	10.182		
SERTOFLEX	70.21	XGAV..LM/SM	10.140		
SKO	10.190	XGAV..LR	10.136		
SKO	10.191	XGAV..SR	10.138		
SKR	10.192	XGEV..LM	10.42		
SR..L/S	10.205	XGEV..LM WD	10.44		
SÜM	60.31	XGEV..LMK	10.52		
TEV..LNPT/SNPT	10.79	XGEV..LNPT	10.54		
TEV..LRK/SRK	10.77	XGEV..LNPT	10.56		
TEV..LR/SR	10.75	XGEV..LR	10.26		
TR..L/S	10.181	XGEV..LR	10.28		
TV..L/S	10.17	XGEV..LR D	10.86		
UEM..L/S	10.204	XGEV..LR WD	10.30		
US-FL/O1	90.19	XGEV..LR WD	10.32		
US-FL/O1-P / -WZ	90.20	XGEV..LRK	10.50		
VDR..M/R	10.209	XGEV..SM	10.46		
VHS	10.193	XGEV..SM WD	10.48		
VKOR..L	10.157	XGEV..SNPT	10.58		
VKO..L/S	10.12	XGEV..SNPT	10.60		
VME..L/S	10.203	XGEV..SR	10.34		
VOE..L/S	10.202	XGEV..SR	10.36		
VOR	10.210	XGEV..SR WD	10.38		
VSA..L/S	10.21	XGEV..SR WD	10.40		
VSI..M	10.198	XGKO..L M	10.10		
VSI..M WD	10.199	XGRKO..L M	10.158		
VSI..R	10.200	XGRKO..L M	10.160		
VSI..R WD	10.201	XGRKO..S M	10.162		
VSS..NPT	40.22	XGRKO..S M	10.164		
VSS..R	40.21	XGR..L	10.166		
WAS..L/S	10.187	XGR..S	10.168		
WEE..LM	10.115	XGR..S	10.170		
WEE..LR	10.113	XGSV..L/S KM	10.22		
WEV..LMK/SMK	10.69	XGV..L/S	10.8		
WEV..LNPT	10.71	XHKS..L/S	50.18		
WEV..LRK	10.65	XKR..L M	10.172		
WEV..LR/SR	10.63	XKR..L M	10.174		
WEV..SNPT	10.73	XKR..S M	10.176		
WEV..SRK	10.67	XKR..S M	10.178		
WSV..L/S	10.25	XKV..L/S	10.18		
WV..L/S	10.15	XLEV..LNPT/SNPT	10.84		
XAVD..L/S	50.38	XLEV..LR	10.80		
XAVI..L/S	50.44	XLEV..LRK/SRK	10.82		
XDRV..L/S	50.26	XMAV..LNPT/SNPT	10.144		
XELKO..L/S M	10.122	XMAV..LR/SR DKR	10.142		
XELV..L/S M	10.124	XNKS-PN 130/100	50.8		
XEMAS..LNPT/SNPT	10.150	XTEV..LNPT/SNPT	10.78		
XEMAS..LR/SR DKR	10.148	XTEV..LRK/SRK	10.76		
XEMV-GV..L/S	10.152	XTEV..LR/SR	10.74		
XERVV..LR WD/SR WD	50.30	XTR..L/S	10.180		
XERVZ..LR WD/SR WD	50.28	XTV..L/S	10.16		
XESS..LM WD/SM WD	10.98	XVSA..L/S	10.20		
XESS..LM/SM	10.96	XWAS..L/S	10.186		
XESS..LNPT/SNPT	10.100	XWEE..LM	10.114		
XESS..LR WD/SR WD	10.94	XWEE..LR	10.112		
XESS..LR/SR	10.92	XWEV..LMK/SMK	10.68		
XESV..L/S	10.188	XWEV..LNPT	10.70		
XESWV..LM WD/SM WD	10.134	XWEV..LRK	10.64		



Seite / Page / Pagina

Montageanleitung Assembly instructions Instrucciones de montaje	Schneid-/NC-Klemmringverschraubungen Cutting/NC clamping ring fittings Racores de anillo cortante/de apriete NC	i.6 - i.11
Montageanleitung Assembly instructions Instrucciones de montaje	Bördel-Rohrverschraubungen Flare tube fittings Racores rebordeados	i.12
Montageanleitung Assembly instructions Instrucciones de montaje	Dichtkegelverschraubungen Tapered seal fittings Racores cónicos	i.13
Montageanleitung Assembly instructions Instrucciones para el prensado	Schlaucharmaturen Hose couplings Armaduras para tubos flexibles	i.14 - i.15
Anzugsdrehmomente für Einschraubgewinde Torques for screw-in threads Pares de apriete para conexión de rosca		i.16
Empfehlungen für Edelstahlrohre Recommendations for stainless steel tubes Recomendación para tubos de acero inox.		i.17 - i.19



**Montageanleitung
Schneidring-/NC-Klemmring-
verschraubungen**

**Assembly Instructions
Cutting/NC clamping ring fittings**

**Instrucciones de montaje
Racores de anillo cortante/
de apriete NC**

1. Rohrvorbereitung

- Rohr rechtwinklig absägen, eine Winkeltoleranz von 0,5° ist zulässig.
- Innere und äußere Kanten entgraten, Rohr reinigen und Späne entfernen.
- Keine Rohrabschneider verwenden.
- Das Rohr muss auf einer Länge von mind. 2x der Höhe der Überwurfmutter gerade sein.

2. Einstufige Montage

2.1. Vorbereitung

- Mit ASW Fettpaste einfetten: 24° Konus und Gewinde des Verschraubungsstutzens, Schneid-/NC-Klemmring (optional), Gewinde der Überwurfmutter

2.2. Montage

- Die Montage erfolgt in einem Arbeitsschritt durch Anziehen der Überwurfmutter mit ca. 1 ¼ bis 1 ½ Umdrehungen (Schneidringverschraubung) bzw. 1 ¾ (NC-Klemmringverschraubungen). Eine Markierung an Mutter und Stutzen sowie zwischenzeitliches, kurzes Lösen der Mutter erleichtern die Montage.

2.3. Kontrolle

- Zur Kontrolle die Überwurfmutter lösen.
- Schneidringeinschnitt prüfen. Der aufgeworfene Bund (siehe Bild) muss deutlich sichtbar sein. / Sitz des NC-Klemmrings prüfen, er darf axial nicht mehr verschiebbar sein.
- Anderenfalls ist ein nochmaliges Anziehen erforderlich (Wiedermontage).

Hinweis: Zur manuellen Montage von Edelstahl-Verschraubungen wird gemäß DIN 3859-2 der Einsatz eines gehärteten Montagewerkzeuges (Schraubenschlüssel) empfohlen, ab Größe 15L ist eine maschinelle Montage ratsam.

Achtung! Abweichende Anzugswege reduzieren die Nenndruckleistung und die Lebensdauer der Verschraubung. Leckagen oder andere Ausfallursachen sind die Folge.

1. Tube preparation

- Cut tube end square, an angular tolerance of 0,5° is allowed.
- Deburr inner and outer edges. Clean the tube and remove the swarf.
- Do not use a tube cutter.
- The tube has to be straight for a length of at least twice the height of nut.

2. One step assembly

2.1. Preparation

- Coat the following parts with ASW grease: 24° taper and thread of the connector, cutting/NC clamping ring (optional), thread of nut

2.2. Assembly

- Assembly is carried out in a single step by tightening the nut with approx. 1 ¼ to 1 ½ turns (cutting ring fittings) or 1 ¾ turns (NC clamping ring fittings). A marking on nut and fitting body as well as an intermediate, brief loosening of the nut facilitates assembly.

2.3. Check

- Loosen nut for checking.
- Check the cutting ring recess. The turned collar (see illustration) must be clearly visible. / Check the seating of NC clamping ring: it must not be able to be moved in axial direction.
- Otherwise the element must be tightened again (re-assembly).

Note: According DIN 3859-2 an assembly tool made of hardened steel (open ended spanner) is recommended for manual assembly of stainless steel fittings. For size 15L and above, machine assembly is advisable.

Attention! Deviating numbers of tightening turns reduce the nominal pressure rating and the life of the fitting, which can cause leakage or other failures.

1. Preparación del tubo

- Cortar el tubo en ángulo recto; se permite una tolerancia angular de 0,5°.
- Desbarbar el tubo por dentro y por fuera. Eliminando las virutas.
- No usar cortatubos ni tronzadoras a muela.
- El tubo debe ser recto en una longitud de min. 2x la altura de la tuerca.

2. Montaje de una etapa

2.1. Preparación

- Lubricar con ASW grasa lubricante: cono de 24° y rosca del cuerpo, anillo cortante/de apriete NC (opcional), rosca de la tuerca de unión

2.2. Montaje

- El montaje se efectúa en un solo paso, apretando la tuerca de unión aproximadamente 1 ¼ a 1 ½ de vuelta (racores de anillo cortante) o 1 ¾ de vuelta (racores de anillo de apriete NC). Una marca en la tuerca y en el racor, además de aflojar brevemente la tuerca, facilitan el montaje.

2.3. Control

- Soltar la tuerca de unión.
- Examinar el corte del anillo cortante. El collar formado debe verse claramente (véase figura). / Comprobar el asiento del anillo de apriete NC, que no debe poder deslizarse axialmente.
- Si es necesario a apretar (repetición del montaje).

Advertencia: Según DIN 3859-2, para el montaje de racores manual de acero inoxidable se recomienda el uso de una herramienta de montaje templada. A partir del tamaño 15L es recomendable un montaje mecanizado.

Atención! Carreras de apriete diferentes reducen la presión nominal estática y la vida útil de la unión roscada. Como consecuencia pueden producirse pérdidas y fallos por otras

Montageanleitung

Schneidring-/NC-Klemmring-
verschraubungen

Assembly Instructions

Cutting/NC clamping ring fittings

Instrucciones de montaje

Racores de anillo cortante/
de apriete NC

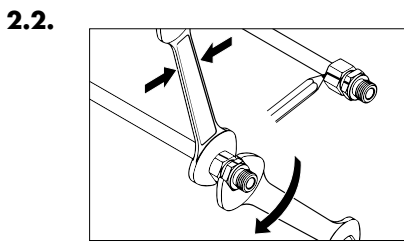
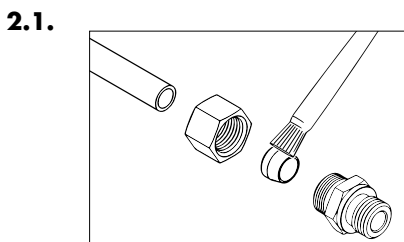
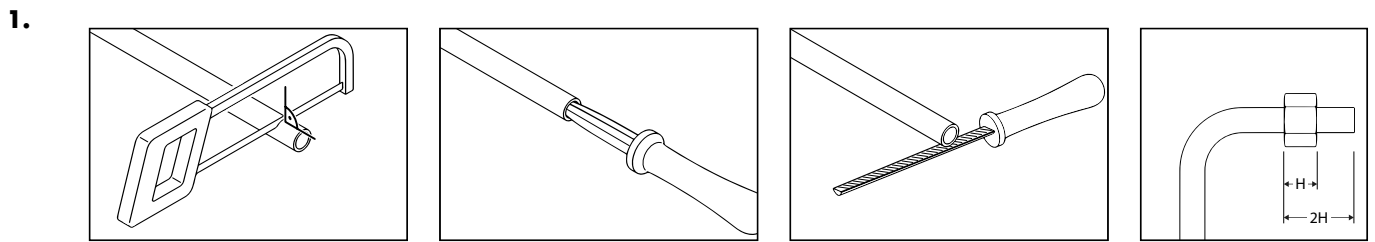

Schneidringverschraubung
ca. 1 ¼ bis 1 ½ Umdrehung

Cutting ring fitting
approx. 1 ¼ to 1 ½ turns

Racores de anillo cortante
aprox. 1 ¼ a 1 ½ vueltas



NC-Klemmringverschraubung
ca. 1 ¾ Umdrehung

NC Clamping ring fitting
approx. 1 ¾ turns

Racores de anillo de apriete NC
aprox. 1 ¾ vueltas

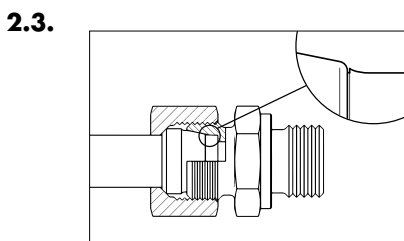

Montageanleitung

Schneidring-/NC-Klemmring-verschraubungen (Fort.)

3. Zweistufige Montage

3.1. Mit Vormontagesutzen HVMS

3.1.1. Vorbereitung

- Zum Rohr passenden Vormontagesutzen in den Schraubstock spannen.
- Mit ASW Fettpaste einfetten: Kegel und Gewinde des Vormontagesutzens, Schneid-/NC-Klemmring (optional), Gewinde der Überwurfmutter
- Auf die richtige Lage des Schneid-/NC-Klemmrings achten – sonst Fehlmontage.
- Überwurfmutter von Hand so weit wie möglich auf den Vormontagesutzen schrauben, dass der Schneid-/NC-Klemmring fest zwischen Rohr und Überwurfmutter anliegt.

3.1.2. Vormontage mit HVMS

- Rohr bis zum Rohranschlag des Stutzens schieben. **Liegt das Rohr am Anschlag nicht an, erfolgt kein Rohreinschnitt / kann das Rohr nicht gehalten werden.** Bei Verwendung von einwandfreiem Rohrmaterial lässt sich das Rohr ohne Kraftaufwand bis zum Rohranschlag schieben, anderenfalls die Rohrenden auf Verformung oder Oberflächenfehler überprüfen. (Beachten Sie hierzu den Abschnitt "Empfehlungen für Edelstahlrohre")
- Überwurfmutter mit einem Schraubenschlüssel ca. 1 Umdrehung anziehen.

3.1.3. Kontrolle

- Zur Kontrolle die Überwurfmutter lösen.
- Schneidringeinschnitt prüfen. Der aufgeworfene Bund (siehe Bild) muss deutlich sichtbar sein. / Sitz des NC-Klemmrings prüfen, er darf axial nicht mehr verschiebbar sein.
- Anderenfalls ist ein nochmaliges Anziehen erforderlich (Wiedermontage).

Hinweis: Ab Größe 15L ist eine maschinelle Montage ratsam.

Hinweis zum Vormontagesutzen

Auch gehärtete Vormontagesutzen unterliegen einem Verschleiß. Nach jeder 50. Vormontage ist die Toleranzhaltigkeit mit einer Konuslehre zu überprüfen. Bei Überschreiten der zugelassenen Toleranzen ist der Vormontagesutzen zu ersetzen.

Assembly Instructions

Cutting/NC clamping ring fittings (cont.)

3. Two step assembly

3.1. With pre-assembly stud HVMS

3.1.1. Preparation

- Firmly clamp the pre-assembly stud in the corresponding tube diameter in a vice.
- Coat the following parts with ASW grease: taper and thread of the pre-assembly stud, cutting/NC clamping ring (optional), thread of nut
- Make sure the cutting/NC clamping ring is positioned correctly to avoid faulty assembly.
- Screw the nut by hand as far as possible on the pre-assembly stud so that the cutting/NC clamping ring lies firmly between the tube and nut.

3.1.2. Pre-assembly with HVMS

- Push the tube up to the stop in the stud. **If the tube does not butt against the stop, the tube will not be cut / the tube will not be clamped.** If the tube material is in perfect condition, the tube can be pushed to the stop without any force. If this is not the case, check the tube ends for deformation or a defective surface. (See section "Recommendations for stainless steel tubes").
- Tighten nut, with the open ended spanner, approx. 1 turn.

3.1.3. Check

- Loosen nut for checking.
- Check the cutting ring recess. The turned collar (see illustration) must be clearly visible. / Check the seating of NC clamping ring: it must not be able to be moved in axial direction.
- Otherwise the element must be tightened again (re-assembly).

Note: For size 15L and above, machine assembly is advisable.

Note concerning pre-assembly stud

Also hardened pre-assembly studs are subject to wear. Periodically, after every 50th pre-assembly the accuracy and tolerance of the taper has to be inspected. In case of heavy wear and non-conformity the stud has to be replaced.

Instrucciones de montaje

Racores de anillo cortante/ de apriete NC (cont.)

3. Montaje de dos etapas

3.1. Con accesorio de premontaje HVMS

3.1.1. Preparación

- Fijar el accesorio de premontaje correspondiente al tubo en el tornillo de banco.
- Lubricar con grasa ASW: cono y rosca del accesorio de premontaje, anillo cortante/de apriete NC (opcional), rosca de la tuerca de unión
- Asegurar la posición correcta del anillo cortante/de apriete NC, de lo contrario, el montaje es incorrecto.
- Atornillar manualmente la tuerca de unión en los accesorios hasta que el anillo cortante/de apriete NC quede encajado firmemente entre el tubo y la tuerca de unión.

3.1.2. Premontaje con HVMS

- Empujar el tubo hasta el tope del racor. **Si el tubo no se ajusta hasta el tope, no se produce el corte en el tubo / no se podrá retener el tubo.** Si el material del tubo está en perfecto estado, el tubo puede empujarse sin esfuerzo hasta el tope; en caso contrario, comprobar si los extremos del tubo están deformados o tienen defectos superficiales. (Consultar también al respecto el apartado "Recomendación para tubos de acero inoxidable".)
- Con una llave, apretar aproximadamente 1 vuelta la tuerca de unión.

3.1.3. Control

- Soltar la tuerca de unión.
- Examinar el corte del anillo cortante. El collar formado debe verse claramente (véase figura). / Comprobar el asiento del anillo de apriete NC, que no debe poder deslizarse axialmente.
- En caso contrario, es preciso volver a apretar (repetición del montaje).

Nota: A partir del tamaño 15L es recomendable (necesario) un montaje mecanizado

Advertencia por accesorio de premontaje

Los accesorios de premontaje templados también se desgastan. Cada 50 operaciones de premontaje, comprobar la precisión de tolerancia con un calibre para conos y cambiar el accesorio de premontaje si supera las tolerancias permitidas.

Montageanleitung

Schneidring-/NC-Klemmring-
verschraubungen (Fort.)

Assembly Instructions

Cutting/NC clamping ring fittings
(cont.)

Instrucciones de montaje

Racores de anillo cortante/
de apriete NC (cont.)



3.1.1.

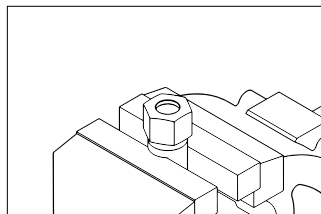
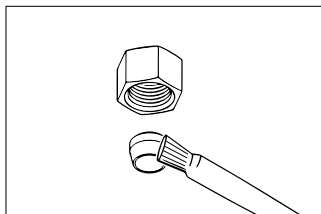
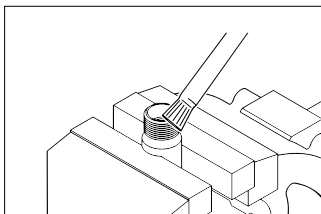

3.1.2.

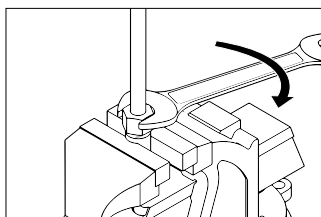
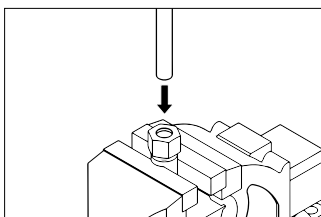

ca. 1 Umdrehung
approx. 1 turn
aprox. 1 vuelta

3.1.3.

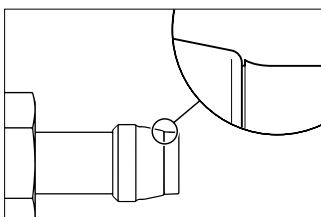

Montageanleitung Schneidring-/NC-Klemmring- verschraubungen (Fort.)

Assembly Instructions Cutting/NC clamping ring fittings (cont.)

Instrucciones de montaje Racores de anillo cortante/ de apriete NC (cont.)

3.2. Mit elektrohydraulischem Vormontagegerät US-FL/01

3.2.1. Vormontage mit US-FL/01

- Überwurfmutter und Schneid-/NC-Klemmring zum Rohrende aufchieben.
- Vorbereitung und Auswahl von Vormontage-
studzen sowie Gegenhalteplatte gemäß den
dem Gerät beiliegenden Instruktionen
- Beachten Sie die von EXMAR empfohlenen
Verpressdrücke im Abschnitt "Empfehlungen
für Edelstahlrohre".

3.2.2 Kontrolle

- Schneidringeinschnitt prüfen. Der aufgeworfene Bund (siehe Bild) muss deutlich sichtbar sein. / Sitz des NC-Klemmrings prüfen, er darf axial nicht mehr verschiebbar sein.
- Anderenfalls ist ein nochmaliges Nachpressen erforderlich.

4. Fertigmontage / Wiederhol montage

- Vormontiertes Rohr in die geschmierte Verschraubung einsetzen. Das Gewinde und der Konus des Stutzens sollen vor der Montage geschmiert werden.
- Die Fertigmontage erfolgt durch ein Nachziehen der Überwurfmutter mit ca. $\frac{1}{4}$ bis $\frac{1}{2}$ Umdrehung (Schneidringverschraubung) bzw. $\frac{3}{4}$ Umdrehung (NC-Klemmringverschraubung).

5. Montage mit Verstärkungshülsen VHS

Um die Funktion der Verschraubung bei dünnwandigen oder weichen Rohren zu gewährleisten, empfehlen wir den Einsatz von EXMAR Verstärkungshülsen.

Montage der Verstärkungshülse

Die Verstärkungshülsen lassen sich leicht und ohne Sonderwerkzeug montieren.

- Das vordere Ende der Verstärkungshülse ist mit einer Rändelung am Außendurchmesser versehen. Die Verstärkungshülse von Hand bis zur Rändelung in das Rohr einstecken.
- Mit einem weichen Hammer (Gummihammer o. ä.) die Verstärkungshülse leicht in das Rohr eintreiben. Die Verzahnung der Rändelung drückt sich nun in das Rohr, ohne dieses aufzuweiten und fixiert die Verstärkungshülse.
- Danach die Rohrmontage durchführen, wie unter 2. oder 3. beschrieben.

Bestellhinweis: Bei Bestellung von Verstärkungshülsen Rohraußendurchmesser und Wandstärke angeben. Rohrgrößen, die mit einer Verstärkungshülse versehen werden sollen, sind im Abschnitt "Empfehlungen für Edelstahlrohre" gekennzeichnet.

3.2. With electro-hydraulic pre- assembly device US-FL/01

3.2.1. Pre-assembly with US-FL/01

- Slide the nut and cutting/NC clamping ring onto the tube end.
- Preparation and selection of pre-assembly stud as well as counter plate according to the instructions included with the device
- Observe the applied pressing power values as recommended by EXMAR in section "Recommendations for stainless steel tubes".

3.2.2. Check

- Check the cutting ring recess. The turned collar (see illustration) must be clearly visible. / Check the seating of NC clamping ring: it must not be able to be moved in axial direction.
- Otherwise, further compression is required.

4. Final assembly / Re-assembly

- Insert the pre-assembled tube in the greased fitting. The thread and the cone of the connector should be greased before mounting.
- Assembly is completed by a final tightening of the nut by approx. $\frac{1}{4}$ to $\frac{1}{2}$ turn (cutting ring fitting) or $\frac{3}{4}$ turn (NC clamping ring fitting).

5. Assembly with reinforcing sleeves VHS

To ensure the correct function of the fitting when using thin-walled or soft tubes, we recommend to use the EXMAR reinforcing sleeves.

Assembly of reinforcing sleeve

Reinforcing sleeves can be easily assembled without any need of special tools.

- The outer front end of the sleeve is knurled. Insert the reinforcing sleeve by hand into the tube up to the knurled section.
- A rubber hammer or soft mallet should be used to lightly drive the reinforcing sleeve into the bore; the knurled ring then being secured without splaying the tube.
- Fitting assembly is proceeded as described in 2. or 3.

Ordering information: When ordering reinforcing sleeves the tube outside diameter and wall thickness should be indicated. Tube sizes, where reinforcing sleeves should be used are indicated in the section "Recommendations for stainless steel tubes".

3.2. Con máquina de premontaje electrohidráulica US-FL/01

3.2.1. Premontaje con US-FL/01

- Deslizar la tuerca de unión y el anillo cortante/ de apriete NC hacia el extremo del tubo.
- Preparación y selección de racor de premontaje, así como placa de sujeción conforme a las instrucciones adjuntas al equipo
- Respetar las presiones de prensado recomendadas por EXMAR en el apartado "Recomendaciones para tubos de acero inox."

3.2.2. Control

- Examinar el corte del anillo cortante. El collar formado debe verse claramente (véase figura). / Comprobar el asiento del anillo de apriete NC, que no debe poder deslizarse axialmente.
- En caso contrario, es preciso volver a apretar.

4. Montaje final / repetición del montaje

- Inserte el tubo premontado en el racor lubricado. La rosca y el cono del racor deben volver a lubricarse antes del montaje final.
- Para el montaje final se aprieta aproximadamente $\frac{1}{4}$ a $\frac{1}{2}$ de vuelta (racores de anillo cortante) o $\frac{3}{4}$ de vuelta (racores de anillo de apriete NC) la tuerca de unión.

5. Montaje con casquillos reforzados VHS

Para poder garantizar la función de los racores para tubos de pared delgada o tubos blandos, recomendamos utilizar casquillos reforzados EXMAR.

Montaje del casquillos reforzados

Los casquillos reforzados se montan fácilmente sin herramientas especiales.

- El extremo delantero del casquillo lleva un moleteado en el diámetro exterior. Introduzca el casquillo con la mano en el tubo hasta el moleteado.
- Encajar el casquillo en el tubo golpeándolo suavemente con un martillo blando (de goma o similar). El dentado del moleteado entra a presión en el tubo sin expandirlo y enclava el casquillo.
- Acto seguido, montar el tubo según se describe en los puntos 2. o 3.

Instrucciones de pedido: Para el pedido de casquillos reforzados, rogamos indicar el diámetro exterior y el grosor del tubo. Las medidas de tubos que deben utilizarse en casquillo reforzado se identifican en el apartado "Recomendaciones p.tubos de acero inox."

Montageanleitung

**Schneidring-/NC-Klemmring-
verschraubungen (Fort.)**

Assembly Instructions

**Cutting/NC clamping ring fittings
(cont.)**

Instrucciones de montaje

**Racores de anillo cortante/
de apriete NC (cont.)**



3.2.1.

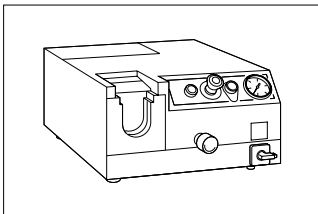

Verpressdruck siehe Abschnitt "Empfehlungen für Edelstahlrohre"

Pressing power see section "Recommendations for stainless steel tubes"

Presión de prensado ver sección "Recomendación para tubos de acero inoxidable"

3.2.2.

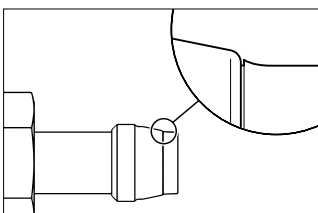

4.

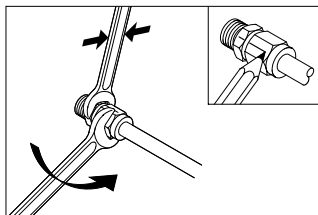
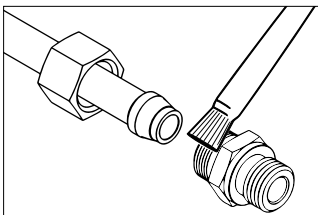

Schneidringverschraubung
ca. ¼ bis ½ Umdrehung

Cutting ring fitting
approx. ¼ to ½ turn

Racores de anillo cortante
aprox. ¼ a ½ vuelta

NC-Klemmringverschraubung
ca. ¾ Umdrehung

NC Clamping ring fitting
approx. ¾ turn

Racores de anillo de apriete NC
aprox. ¾ vuelta

5.

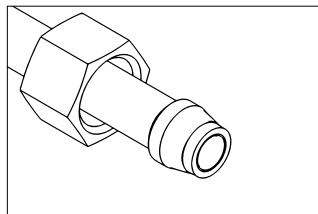
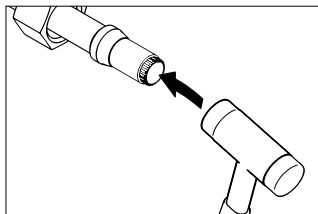
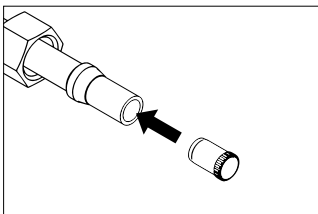

Montageanleitung Bördel-Rohrverschraubungen

1. Alle miteinander reibenden Verschraubungsteile sorgfältig einfetten (ASW Fettpaste).
2. Das zu verlegende Rohr rechtwinklig absägen. ACHTUNG, keinen Rohrabstreifer verwenden!
3. Das Rohr innen und außen entgraten, nicht anfasen!
4. Rohrende reinigen, da sonst die Dichtfläche des Rohres beim Bördeln beschädigt wird.
5. Bördel-Verschraubungsteile über das Rohrende schieben.
6. Rohr in Bördelmaschine oder Bördelwerkzeug für Schraubstock aufbördeln. Auf Risse überprüfen.
7. Bördel-Zwischenring (unverlierbar) in Verschraubung einlegen und aufgebördeltes Rohr an Zwischenring anlegen. Überwurfmutter (Druckring einseitig) von Hand anziehen, bis deutlicher Widerstand spürbar ist.
8. Anschließend Fertigmontage mit ca. ¼ bis ½ Umdrehungen.

Wiederholmontage

Nach Lösen der Verbindung ist der Wiederaufbau ohne erhöhten Kraftaufwand vorzunehmen.

Rohrauswahl

Es ist eine bördelfähige Rohrqualität zu verwenden, vorzugsweise nahtloses Präzisionsedelstahlrohr nach DIN 17 458, Toleranzen nach DIN EN 10 305-1, Werkstoff 1.4571 / AISI 316 Ti oder einen gleichwertigen Werkstoff.

Dichtungen

Serienmäßig:
- FKM
- Temperaturbereich -20°C bis +200°C

Werkzeuge

Werden Bescheinigungen über Materialprüfungen DIN 10 204 gewünscht, so ist dies bei der Bestellung anzugeben (Abnahmeprüfzeugnis 3.1 gegen Berechnung).

Assembly Instructions Flare tube fittings

1. Carefully grease all the fitting parts which rub against each other with ASW grease.
2. Cut the tube to be installed at right angles. ATTENTION, do not use a tube cutter!
3. Deburr the tube inside and outside. Do not chamfer!
4. Clean tube ends so the sealing surface will not be damaged when flaring.
5. Slide flare connection parts onto tube end.
6. Flare tube end with flaring machine or vice flaring tool. Check piece for fissures.
7. Insert flare adaptor (und detachable) into fitting and connect flare tube to the adaptor. Tighten nut (flare sleeve inside) by hand.
8. Tighten flare nut approx. ¼ to ½ turn beyond the point where resistance is felt for final assembly.

Re-assembly

Each time the fitting is disconnected the nut must be re-tightened without using excessive force.

Tubes

A tube quality suitable for flaring should be used, preferably seamless precision stainless steel tube according to DIN 17 458, tolerances per DIN EN 10 305-1, material 1.4571 / AISI 316 Ti or equivalent material.

Seals

Standard seals:
- FKM
- Temperature range from -20°C to +200°C

Material certificates

Requests for verification of material tests according to DIN 10 204 should be made when placing the order (inspection certificate 3.1, cost will be charged).

Instrucciones de montaje Racores rebordado

1. Engrasar a fondo todas las piezas con rozamiento de la unión roscada (ASW grasa lubricante).
2. Cortar el tubo para montar en ángulo recto. ATENCIÓN: no usar cortatubos.
3. Desbarbar el tubo por fuera y dentro, sin tocarlo.
4. Limpiar el extremo de tubo porque la superficie de obturación del tubo puede quedar dañada al rebordar.
5. Introducir el extremo del tubo a través de las piezas del racor rebordado.
6. Rebordar el tubo en una máquina o herramienta de rebordar para tornillo de banco. Comprobar si hay grietas.
7. Colocar el anillo intermedio rebordado (imperdible) en el racor y apoyar el tubo rebordado contra el adaptador. Apretar la tuerca de unión con la mano.
8. Apretar la tuerca de unión hasta notar una clara resistencia. Finalizar el montaje apretando aproximadamente ¼-½ vuelta.

Repetición del montaje

Después de aflojar la unión, repetir el apriete sin aplicar más fuerza.

Selección de tubos

Utilizar una calidad de tubos aptos para rebordar. Preferiblemente tubos de acero inoxidable de precisión, sin costuras, según DIN 17 458, con tolerancias según DIN EN 10 305-1, material 1.4571 / AISI 316 Ti o material equivalente.

Juntas

De serie:
- FKM
- Intervalo de temperatura -20°C a +200°C

Certificados de material

Si se necesitan certificados de ensayos de material según DIN 10 204, deberá especificarse al realizar el pedido (se facturará a partir del certificado de recepción 3.1).

Montageanleitung
Dichtkegelverschraubungen

Assembly Instruction
Tapered seal fittings

Instrucciones de montaje
Racores cónicos

1. Alle miteinander reibenden Verschraubungsteile sorgfältig einfetten (ASW Fettpaste).
2. Rohranschluss in gewünschte Richtung ausrichten und Überwurfmutter bis zum fühlbaren Kraftanstieg von Hand festziehen.
3. Überwurfmutter ¼ Umdrehung anziehen. Dazu Verschraubungsstutzen mit Schlüssel gegenhalten.

Achtung! Abweichende Anzugswege reduzieren die Nenndruckleistung und die Lebensdauer der Verschraubung. Leckagen oder andere Ausfallursachen sind die Folge.

1. All the fitting parts which produce friction must be carefully greased (ASW grease).
2. Align the tube connection in the desired direction and hand-tighten the nut until the tightening force increases noticeably.
3. Tighten the nut ¼ turns. In doing so, hold the connector steady with a open ended spanner.

Attention! Deviating tightening procedures reduce the nominal pressure performance and the service life of the connection. This may result in leakage or other failures.

1. Engrasar a fondo todas las piezas con rozamiento de la unión roscada (ASW grasa lubricante).
2. Alinear la conexión en la dirección deseada y apretar manualmente la tuerca de unión hasta que la fuerza de apriete aumente notablemente..
3. Apretar la tuerca de unión ¼ de vuelta. Sujetar el cuerpo con una llave.

Atención! Carreras de apriete diferentes reducen la presión nominal estática y la vida útil de la unión roscada. Como consecuencia pueden producirse pérdidas y fallos por otras causas.

Montageanleitung
Schlaucharmaturen

Assembly Instructions
Hose couplings

Instrucciones de montaje
Armaduras para tubos flexibles

Anleitung zum Verpressen

- Wählen Sie alle Komponenten zur Fertigung der Schlauchleitung anhand unseres aktuellen Kataloges aus. Für die anschlussseitigen Befestigungen stehen eine Reihe von Armaturen zur Verfügung.
Schlaucharmaturen müssen so ausgewählt werden, dass sie den zu erwartenden mechanischen, thermischen und chemischen Beanspruchungen standhalten.
- Schneiden Sie den ausgewählten Schlauch mit einem für den Schlauch vorgesehenen Schneideblatt senkrecht auf die gewünschte Länge.
- Setzen Sie die Pressfassung komplett über das Schlauchende und schieben Sie diese bis zum Anschlag über den Schlauch.
Schmieren Sie das schlauchseitige Fußteil des Nippels mit unserer ASW-Fettpaste, danach schieben Sie den Nippel in das Schlauchende. Überprüfen Sie, ob die Einhängenut zwischen Fassung und Schlauchnippel richtig positioniert wurde.
- Zum Verpressen der Schlauchleitung wählen Sie den Pressbackensatz, der dem angegebenen Pressmaß am nächsten liegt, aus. Bei z.B. einem Pressmaß von 23 mm verwenden Sie einen Backensatz von 22 mm.
- Um die Verpressung zu kontrollieren, prüfen Sie mit Hilfe einer Schieblehre den Durchmesser der nun verpressten Fassung, mittig, in drei verschiedenen Positionen, ca. 120° voneinander versetzt. Diese drei Messungen müssen dem Pressmaß entsprechen. Falls das Pressmaß nicht erreicht wurde, erhöhen Sie die Einstellung Ihrer Maschine in 0.1 mm Schritten, um den korrekten Durchmesser zu erreichen.
Trotz empfohlenem Pressmaß ist es notwendig, den Nippeleinfall zu messen. Der korrekte Nippeleinfall beträgt in der Regel, je nach Durchmesser, zwischen 0.2 und 1.4 mm.
- Eine zweifache Verpressung ist zu vermeiden, da dies die Lebenserwartung einer Schlauchleitung verringert. Benutzen Sie daher Pressbacken, die lang genug sind, um die Fassung komplett zu verpressen.
Pressfassungen dürfen nicht wiederverwendet werden.
- Die Kennzeichnung muss dauerhaft und unter Berücksichtigung der jeweiligen Schlauchnormen erfolgen.

Pressing instructions

- Select all the components you need for your hose line from our current catalogue. We have a number of connection options to choose from.
Hose fittings must be selected according to the anticipated mechanical, thermal and chemical loads.
- Cut the selected hose to length, perpendicularly with a blade appropriate for hoses.
- Slide the ferrule completely over the hose until the stop.
Grease the hose side part of the nipple with our ASW grease and then insert the nipple in the hose end. Check, that the groove between the socket and the hose nipple is positioned correctly.
- Use the press jaws closest in dimension, e.g. for a press dimension of 23 mm, use 22 mm jaws.
- With the help of a slide gauge, check the diameter of the pressed socket, centred, in three different positions, approx. 120° apart. These three measurements must correspond to the press dimension. If the press dimension has not been realized, increase the setting on your machine in 0.1 mm increments until the correct diameter is reached.
Despite the recommended press dimension, it is also necessary to measure the nipple deformation. The correct nipple deformation is generally between 0.2 und 1.4 mm, depending on the diameter.
- A second pressing should be avoided since this reduces the life expectancy of a hose line. That is why press jaws should be used which are long enough to completely press the socket.
Press sockets may not be reused.
- Identification must be permanent and according to the respective hose standards.

Instrucciones de prensado

- Elegir los componentes para la elaboración de tuberías flexibles en nuestro catálogo actual. Para las fijaciones del lado de conexión puede elegirse entre varias valvulerías.
Elegir valvulerías para las tuberías flexibles que resistan las cargas mecánicas, térmicas y químicas esperadas.
- Cortar el tubo flexible elegido con una cuchilla adecuada, tronzando en perpendicular a la longitud deseada.
- Introducir el extremo del tubo completamente en el casquillo para prensar y empuje el casquillo sobre el tubo hasta llegar al tope.
Lubricar la pieza base de la boquilla del lado del tubo con nuestra ASW grasa lubricante e introducir la boquilla en el extremo del tubo. Comprobar si la ranura de enganche entre la valvulería y la boquilla del tubo flexible se ha situado correctamente.
- Para prensar la tubería flexible, elegir el juego de mordazas de prensado que mejor se ajuste a la medida de prensado especificada. Para una medida de prensado de 23 mm, por ejemplo, utilizar un juego de mordazas de 22 mm.
- Para verificar el prensado, utilizar un pie de rey para comprobar el diámetro del engaste prensado en el centro en tres posiciones diferentes, separadas aproximadamente 120° una de otra. Las tres mediciones deben corresponder a la medida de prensado. Si no se alcanza la medida de prensado, aumentar el ajuste de la maquina en pasos de 0.1 mm hasta conseguir el diámetro correcto.
Pese a la medida de prensado recomendada, es necesario medir el grado de compresión de la boquilla. La compresión correcta de la boquilla suele ser de 0.2 a 1.4 mm, según diámetro.
- Evitar el prensado doble, pues acorta la esperanza de vida de la tubería flexible.
Utilizar mordazas de prensado que sean suficientemente largas para prensar el engaste completo.
Los engastes de prensado no deben reutilizarse.
- La identificación ha de ser indeleble y realizarse de acuerdo con las oportunas normas para tubos flexibles.

Montageanleitung**Schlaucharmaturen** (Forts.)**Assembly Instructions****Hose couplings** (cont.)**Instrucciones de montaje****Armaduras para tubos flex.** (cont.)**Anmerkung**

- Sämtliche Fertigungstoleranzen sowie weitere technische Informationen zur Fertigung von Schlauchleitungen entnehmen Sie der DIN 20066.
- Wir weisen darauf hin, dass sich die genannten Angaben zur Fertigung von Schlauchleitungen nur auf die Verwendung von EXMAR-Produkten beziehen. Bei Verwendung anderer Fabrikate ist ein Kompatibilitätstest anzufordern.

Note

- All manufacturing tolerances as well as additional technical data on the manufacture of hose lines can be found in DIN 20066.
- We would like to point out that the above information on assembling hose lines is only applicable to the use of EXMAR products. If other brands are used, a compatibility test should be requested.

Nota

- Para conocer las tolerancias de fabricación y demás información técnica relativa a la elaboración de tuberías flexibles, consultar la norma DIN 20066.
- Hacemos hincapié en que los datos mencionados para la fabricación de tuberías flexibles se refieren solamente a la utilización de productos EXMAR. Para utilizar productos de otras marcas deberá solicitarse una prueba de compatibilidad.

Anzugsdrehmomente für Einschraubgewinde



(Richtwerte in Nm)

Torques for screw-in threads

(standard values in Nm)

Pares de apriete para conexión de rosca

(standard values in Nm)

	<p>für Gewinde mit Dichtkante Form B nach DIN 3852-1/-2, ISO 1179-4</p> <p>for threads with sealing edge form B acc. ISO 1179-2</p> <p>para rosca con borde de obturación forma B según DIN 3852-2</p>		<p>für Gewinde mit Weichdichtung Form E nach ISO 1179-2</p> <p>for threads with elastomer seal form E acc. ISO 1179-2</p> <p>para rosca con junta blanda forma E según ISO 1179-2</p>
---	--	--	---

Gewinde Thread Rosca	Reihe L series L serie L	Reihe S series S serie S	VSI Verschluss- schrauben	Reihe L series L serie L	Reihe S series S serie S	VSI Verschluss- schrauben
----------------------------	--------------------------------	--------------------------------	---------------------------------	--------------------------------	--------------------------------	---------------------------------

**zölliges, zylindrisches Einschraubgewinde, ISO 228, Toleranzklasse A
imperial withworth male adaptor thread, ISO 228, tolerance class A
conexión de rosca cilíndrica BSP, ISO 228, clase de tolerancia A**

G 1/8	30	35	20	25	30	20
G 1/4	55	60	35	50	60	35
G 3/8	90	110	90	80	100	90
G 1/2	130	160	140	120	150	140
G 3/4	200	250	180	180	200	180
G 1	350	400	200	300	350	200
G 1 1/4	500	550	400	450	500	400
G 1 1/2	600	650	450	500	550	450

**metrisches, zylindrisches Einschraubgewinde, DIN 13, Toleranzklasse 6g
metric, parallel male adaptor thread, DIN 13, tolerance class 6g
conexión de rosca métrica, cilíndrica, DIN 13, clase de tolerancia 6g**

M 10x1.0	30	35	12	25	30	12
M 12x1.5	40	45	25	30	35	25
M 14x1.5	60	70	35	50	55	35
M 16x1.5	90	110	50	70	90	50
M 18x1.5	110	130	65	80	100	65
M20x1.5	130	160	80	120	150	80
M 22x1.5	160	190	90	150	180	90
M 26x1.5	200	250	135	180	200	135
M 27x2.0	250	300	170	200	250	170
M 33x2.0	350	400	225	300	350	225
M 42x2.0	500	550	350	450	500	350
M 48x2.0	600	650	350	500	550	350

Wichtige Hinweise:

- Die in der Tabelle angegebenen Anzugsdrehmomente [in Nm] sind Richtwerte.
- Die Werte können, abhängig vom verwendeten Material, den Toleranzen, der Schmierung und der Oberflächenbeschaffenheit des Gegenkörpers, stark variieren.
- Die Anzugsdrehmomente unterliegen einer Toleranz von ±10 %.
- Einschraubgewinde vor dem Einschrauben mit geeigneten Mitteln schmieren.
- Die angegebenen Werte gelten für die Materialpaarung Einschraubverschraubung/ Gegenkörper Edelstahl 1.4571/AISI 316 Ti.
- Die Werte gelten nicht für Schwenkverschraubungen.

Important information:

- The tightening torques stated in the table [in Nm] are guideline values.
- The values may vary greatly, depending on the material used, the tolerances, the lubrication and the surface properties of the mating material.
- The tightening torques are subject to a tolerance of ±10 %.
- Lubricate the male thread with a suitable lubricant before screwing it in.
- The stated values apply for the material pair male adaptor/counter body stainless steel 1.4571 / AISI 316 Ti.
- The values do not apply for banjo elbow fittings.

Indicaciones importantes:

- Los pares de apriete indicados en la tabla [en Nm] son valores orientativos.
- Los valores pueden variar sensiblemente dependiendo del material utilizado, de las tolerancias, de la lubricación y del acabado de la superficie del contracuerpo.
- Los pares de apriete tienen una tolerancia del ±10 %.
- Lubricar las roscas de conexión con agentes adecuados antes de enroscar.
- Los valores indicados son válidos para la combinación de materiales racor enroscable/ contracuerpo de acero inoxidable 1.4571 / AISI 316 Ti.
- Los valores no se aplican a racores orientables.

Empfehlungen für Edelstahlrohre

Recommendations for stainless steel tubes

Recomendación para tubos de acero inoxidable

Material

Edelstahl 1.4571 / AISI 316 Ti oder 1.4301 / AISI 304

Ausführung

nahtlos, kalt gefertigt, blankgeglüht, Lieferzustand CFA, EN 10305-1 / EN 10216-5 / ISO 1127

Toleranzen

- EN 10305-1, Option 10 (Außen-Ø nach Tabelle 5)
- ISO 1127 (Toleranzklassen D4/T3)

Oberflächenbeschaffenheit

- zunderfrei
- frei von Oberflächenbeschädigungen (Vorsichtige Handhabung ist erforderlich!)
- Rohre müssen riefenfrei sein

Härte

- wie gefertigt
- empfohlene Vickershärte 155-178 HV
- geeignet zum Biegen

Handhabung

- Rohre nicht über harte Unterlagen schleifen (z.B. Zement, Asphalt, Schotter oder Metalle)
- Rohrenden beim Transport und Handling schützen (mit Kunststoff-Kappen, Klebstreifen usw.)
- Rohre nicht aus dem Gestell zerren
- nur scharfe Rohrabstecher oder Bügelsägen verwenden und zu tiefe Schnitte pro Umdrehung oder Hubbewegung vermeiden
- Rohrenden immer innen und außen entgraten
- Verunreinigungen und Späne können zu Störungen in der Anlage und zu Leckagen führen

Spezielle Ausführung

Fragen Sie uns für geschweißte Rohre an, wir beraten Sie gerne.

Material

Stainless steel 1.4571 / AISI 316 Ti or 1.4301 / AISI 304

Type

seamless, cold finished, bright, annealed, state of delivery CFA, according to EN 10305-1 / EN 10216-5 / ISO 1127

Tolerances

- EN 10305-1, option 10 (outer Ø according to table 5)
- ISO 1127 (tolerance classes D4/T3)

Surface finish

- non-scaling
- no surface damage (careful handling is essential!)
- tubes must be free of grooves

Hardness

- as manufactured
- recommended Vickers hardness 155-178 HV
- suitable for bending

Handling

- do not grind tubes on hard surfaces (e.g. cement, asphalt, gravel or metals)
- protect tube ends during transport and handling (with plastic caps, adhesive tape, etc.)
- lift tubes carefully out of case
- use only sharp tube cutters or hack saws and avoid cutting too deep in one turn
- always deburr tube ends inside and out
- contamination and shavings can cause damage in the system and lead to leakage

Special version

Ask us about welded tubes, we will be happy to advise you.

Material

acero inoxidable 1.4571 / AISI 316 Ti o 1.4301 / AISI 304

Ejecución

sin costuras, fabricado en frío, recocado brillante, estado de suministro CFA, EN 10305-1 / EN 10216-5 / ISO 1127

Tolerancias

- EN 10305-1, opción 10 (Ø exterior según la tabla 5)
- SO 1127 (clase de tolerancia D4/T3)

Acabado de superficies

- sin cascarilla
- libre de defectos de superficie (manipular con precaución)
- los tubos deben estar libres de estrías

Dureza

- como fabricado
- dureza Vickers recomendada 155-178HV
- adecuados para doblar

Manipulación

- no arrastrar los tubos sobre bases duras (p. ej., cemento, asfalto, grava o metales)
- proteger los extremos de los tubos durante el transporte y la manipulación (con capuchones de plástico, cintas adhesivas, etc.)
- no sacar violentamente los tubos del soporte
- utilizar siempre cortatubos o sierras de arco afilados y evitar cortes demasiado profundos por vuelta o carrera
- desbarbar siempre el interior y exterior de los extremos
- la suciedad y las virutas pueden provocar fallos de la instalación y fugas

Acabados a medida

Consulte nuestra oferta de tubos soldados; con mucho gusto le asesoraremos

**Empfehlungen für
Edelstahlrohre** (Forts.)

**Recommendations for
stainless steel tubes** (cont.)

**Recomendación para
tubos de acero inox.** (cont.)

**Verpressdruck für die Montage von
EXMAR-Verschraubungen**
**Pressing power for assembly of
EXMAR tube fittings**
**Presión estándar para montaje
del racores EXMAR**

Schneidringverschraubung – Niederdruck Cutting ring fitting – low pressure Racor de anillo cortante – baja presión max. / máx. 16 bar			
Größe Size Tamaño	Rohr-Ø Tube-Ø Tubo-Ø	Nennndruck Pressure nom. Presión nom. [bar]	Verpressdruck Pressing power Presión de prensado [bar]
6L	6x1	16	20
8L	8x1	16	30
10L	10x1	16	30
12L	12x1.5	16	30
15L	15x1.5	16	35
18L	18x1.5	16	45
22L	22x1.5	16	55
28L	28x1.5	16	65
35L	35x2	16	90
42L	42x2	16	100
6S	-	-	-
8S	-	-	-
10S	-	-	-
12S	-	-	-
14S	-	-	-
16S	-	-	-
20S	-	-	-
25S	-	-	-
30S	-	-	-
38S	38x3	16	100

Schneidringverschraubung – Normdruck Cutting ring fitting – standard pressure Racor de anillo cortante – presión estándar gemäß / acc. / según ISO 8434-1			
Größe Size Tamaño	Rohr-Ø Tube-Ø Tubo-Ø	Nennndruck Pressure nom. Presión nom. [bar]	Verpressdruck Pressing power Presión de prensado [bar]
6L	6x1	250	20
8L	8x1	250	30
10L	10x1	250	35
12L	12x1.5	250	35
15L	15x1.5	250	40
18L	18x2	160	60
22L	22x2.5	160	70
28L	28x2.5	100	80
35L	35x2.5	100	100
42L	42x3	100	160
6S	6x1	630	20
8S	8x1.5	630	30
10S	10x1.5	630	35
12S	12x2	630	35
14S	14x2	630	40
16S	16x2	400	55
20S	20x2.5	400	80
25S	25x2.5	400	105
30S	30x3	250	130
38S	38x3*	250	160

Der Verpressdruck in [bar] entspricht dem einzustellenden Druck an der Vormontagemaschine.

Wird die angegebene Rohrwandstärke unterschritten, ist eine Verstärkungshülse zu verwenden. Ist die entsprechende Dimension der Verstärkungshülse nicht erhältlich, muss eine andere Rohrdimension eingesetzt werden.

Für die mit einem * versehenen Rohrabmessungen empfehlen wir den Einsatz einer Verstärkungshülse (siehe VHS in Kapitel 10).

The pressing power in [bar] corresponds to the pressure to be set on the pre-assembly device.

A reinforcing sleeve must be used for tubes with lesser wall thickness. If no suitable size is available, we urgently recommend the use of an alternative tube dimension for safety reasons.

For the tube sizes indicated with a * we recommend to use a reinforcing sleeve (see VHS in chapter 10).

La fuerza de prensado en [bar] corresponde a la presión que debe ajustarse en la máquina de premontaje.

Emplear un casquillo reforzado en caso de utilizar tubos de paredes más delgadas de lo indicado en este documento. Por razones de seguridad, se aconseja encarecidamente utilizar una dimensión de tubo alternativa si no se encuentra el tamaño adecuado.

Recomendamos utilizar casquillos reforzados para las medidas de tubos identificadas con un * (ver VHS in capítulo 10).

**Empfehlungen für
Edelstahlrohre** (Fortsetzung)

**Recommendations for
stainless steel tubes** (cont.)

**Recomendación para
tubos de acero inox.** (cont.)

**Verpressdruck für die Montage von
EXMAR-Verschraubungen**
**Pressing power for assembly of
EXMAR tube fittings**
**Presión estándar para montaje
del racores EXMAR**

Schneidringverschraubung – erhöhter Druck Cutting ring fitting – increased pressure Racor de anillo cortante – aumento de la presión gemäß Katalog / acc. catalog / según catálogo			
Größe Size Tamaño	Rohr-Ø Tube-Ø Tubo-Ø	Nenndruck Pressure nom. Presión nom. [bar]	Verpressdruck Pressing power Presión de prensado [bar]
6L	6x1	500	20
8L	8x1.5	500	30
10L	10x2	500	40
12L	12x2	400	40
15L	15x2	400	40
18L	18x3	400	60
22L	22x3	250	70
28L	28x3	250	80
35L	35x4	250	120
42L	42x4	250	220
6S	6x1.5	800	20
8S	8x1.5	800	30
10S	10x2	800	40
12S	12x2.5	630	40
14S	14x3	630	40
16S	16x3	630	55
20S	20x3	420	90
25S	25x3.5	420	105
30S	30x4	420	180
38S	38x5	420	220

NC-Klemmringverschraubung – Normdruck NC Clamping ring fitting – standard pressure Racor de anillo de apriete NC – presión estándar gemäß / acc. / según ISO 8434-1			
Größe Size Tamaño	Rohr-Ø Tube-Ø Tubo-Ø	Nenndruck Pressure nom. Presión nom. [bar]	Verpressdruck Pressing power Presión de prensado [bar]
6L	6x1.5	400	20
8L	8x2/8x1.5*	400	30
10L	10x2/10x1.5*	250	30
12L	12x2/12x1.5*	250	35
15L	15x2/15x1.5*	250	40
18L	18x2/18x1.5*	160	60
22L	22x3	160	70
28L	-	-	-
35L	-	-	-
42L	-	-	-
6S	6x1.5	500	20
8S	8x2/8x1.5*	500	30
10S	10x2/10x1.5*	400	30
12S	12x2/12x1.5*	400	35
14S	14x2/14x1.5*	300	45
16S	16x2/16x1.5*	200	55
20S	20x2/20x1.5*	200	80
25S	25x2.5	100	100
30S	-	-	-
38S	-	-	-

Der Verpressdruck in bar entspricht dem einzustellenden Druck an der Vormontagemaschine.

Wird die angegebene Rohrwandstärke unterschritten, ist eine Verstärkungshülse zu verwenden. Ist die entsprechende Dimension der Verstärkungshülse nicht erhältlich, muss eine andere Rohrdimension eingesetzt werden.

Für die mit einem * versehenen Rohrabmessungen empfehlen wir den Einsatz einer Verstärkungshülse (siehe VHS in Kapitel 10).

The pressing power in bar corresponds to the pressure to be set on the pre-assembly device.

A reinforcing sleeve must be used for tubes with lesser wall thickness. If no suitable size is available, we urgently recommend the use of an alternative tube dimension for safety reasons.

For the tube sizes indicated with a * we recommend to use a reinforcing sleeve (see VHS in chapter 10).

La fuerza de prensado en [bar] corresponde a la presión que debe ajustarse en la máquina de premontaje.

Emplear un casquillo reforzado en caso de utilizar tubos de paredes más delgadas de lo indicado en este documento. Por razones de seguridad, se aconseja encarecidamente utilizar una dimensión de tubo alternativa si no se encuentra el tamaño adecuado.

Recomendamos utilizar casquillos reforzados para las medidas de tubos identificadas con un * (ver VHS in capítulo 10).

**Schneidring-
verschraubungen**

**Cutting ring
fittings**

**Racores de anillo
cortante**

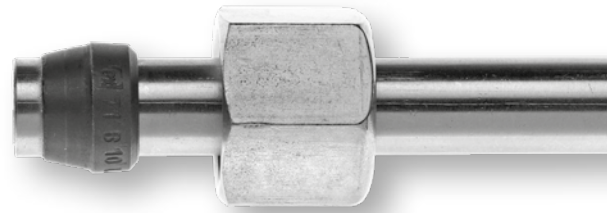
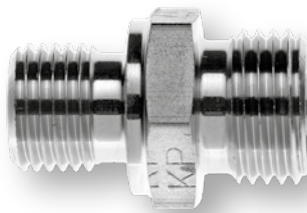

Seite/Page/Página	Seite/Page/Página	Seite/Page/Página
<p>Rohrverschraubungen Tube fittings Racores de conexión</p>	<p>Gerade Schottverschraubungen Bulkhead fittings Racores pasatabiques rectos</p>	<p>Einstellbare Verschraubungen Adjustable fittings Racores ajustables</p>
<p>10.8-10.9</p> <p>Gerade Verschraubungen Straight fittings Racores rectos</p> <p>GV</p>	<p>10.22-10.23</p> <p></p> <p>GSV</p>	<p>10.89-10.91</p> <p>Gerade Einschraubstutzen mit Dichtkegel Straight male adaptor unions with taper Racores para rosca rectos con junta cónica</p> <p>EGKO</p>
<p>10.10-10.11</p> <p>Gerade Verschraubungen mit Dichtkegel Straight fittings with taper Racores rectos con junta cónica</p> <p>GKO</p>	<p>10.24-10.25</p> <p>Winkel-Schottverschraubungen Bulkhead elbow fittings Racores pasatabiques a codo</p> <p>WSV</p>	<p>10.92-10.101</p> <p>Einschraubstutzen mit Schaft Male adaptor standpipe unions Racores para rosca con vástago</p> <p>ESS</p>
<p>10.12</p> <p>Gerade Zwischenstutzen mit Dichtkegel Straight unions with taper Racores de unión rectos con junta cónica</p> <p>VKO</p>	<p>10.26-10.61</p> <p>Gerade Einschraubverschraubungen Straight male adaptor fittings Racores para rosca rectos</p> <p>GEV</p>	<p>10.102-10.111</p> <p>Einstellbare Winkelverschraubungen Adjustable elbow fittings Racores angulares ajustables</p> <p>EWKO 45° /EWKO/EWV</p>
<p>10.14-10.15</p> <p>Winkelverschraubungen Elbow fittings Racores codo</p> <p>WV</p>	<p>10.62-10.73</p> <p>Winkel-Einschraubverschraubungen Male adaptor elbow fittings Racores para rosca en codo</p> <p>WEV</p>	<p>10.112-10.115</p> <p>Einstellbare Winkel-Einschraubverschr. Adjustable male adaptor elbow fittings Racores para rosca en codo ajustables</p> <p>WEE</p>
<p>10.16-10.17</p> <p>T-Verschraubungen T fittings Racores T</p> <p>TV</p>	<p>10.74-10.79</p> <p>T-Einschraubverschraubungen Male adaptor T fittings Racores para rosca T</p> <p>TEV</p>	<p>10.116-10.127</p> <p>Einstellbare T-/L-Verschraubungen Adjustable T/L fittings Racores T/L ajustables</p> <p>ETKO/ETV / ELKO/ELV</p>
<p>10.18-10.19</p> <p>Kreuz-Verschraubungen Cross fittings Racores en cruz</p> <p>KV</p>	<p>10.80-10.85</p> <p>L-Einschraubverschraubungen Male adaptor L fittings Racores para rosca L</p> <p>LEV</p>	<p>Schwenkverschraubungen Banjo fittings Racores orientables</p>
<p>10.20-10.21</p> <p>Verschlussverschraubungen Locking fittings Racores de cierre</p> <p>VSA</p>	<p>10.86-10.88</p> <p>Gerade Thermoelementversch. Straight fittings for temperature sensors Racores de termosonda</p> <p>GEV-D</p>	<p>10.128-10.135</p> <p>Winkel-Schwenkverschraubungen Banjo elbow fittings Racores orientables angulares</p> <p>ESWV</p>

Seite/Page/Página

Seite/Page/Página

Seite/Page/Página

**Aufschraub-/Manometerverschr.
Female adaptor/Manometer fittings
Racores rectos/para manómetro**

10.136-10.141

Gerade Aufschraubverschraubungen
Straight female adaptor fittings
Racores atornillables rectos



GAV

10.142-10.145

Manometer-Anschlussverschraubungen
Manometer fittings
Racores para manómetro



MAV

10.147-10.151

Einstellbare Manometerverschraubungen
Adjustable manometer fittings
Racores para manómetro ajustables



EMAKO/EMAS

10.152-10.155

Gerade Messverschraubungen
Straight fittings with test gauge
Racores de medición rectos



EMV

**Reduzierschraubungen
Reducing fittings
Racores de reducción**

10.157-10.179

Gerade Reduzierschraubungen
Straight reducing fittings
Racores de reducción rectos



VKOR/GRKO/GR/KR

10.180-10.181

T-Reduzierschraubungen
Reducing T fittings
Racores de reducción T



TR

**Anschweißverschraubungen
Weldable fittings
Racores para soldar**

10.182-10.185

Gerade Anschweißverschraubungen
Straight weld-on fittings
Racores para soldar rectos



GAS/GASK

10.186-10.187

Winkelanschweißverschraubungen
Elbow weld-on fittings
Racores para soldar angulares



WAS

10.188-10.189

Einschweiß-Schottverschraubungen
Weld-in bulkhead fittings
Racores de paso de mamparo para soldar



ESV

10.190-10.192

Schweißkegel
Weldable cones
Conos para soldar



SKO/SKR

**Einzelteile
Single parts
Componentes**

10.193

Verstärkungshülsen
Reinforcing sleeves
Manguitos de refuerzo



VHS

10.194-10.197

Gewinde-Reduzierstutzen
Reducing adaptors
Racores de reducción roscados



RS

Verschlusschrauben
Locking screws
Tornillos de cierre

10.198-10.201



VSI

Verschlussstopfen
Blanking plugs
Tapónes

10.202-10.203



VOE/VME

10.204

Überwurfmuttern
Nuts
Tuercas de unión



UEM

10.205

Schneidringe
Cutting rings
Anillos cortantes



SR

10.206

Kontermuttern
Counter nuts
Contratuercas



KM

10.207-10.208

Dichtkantenringe
Seal edge rings
Anillos con borde de obturación



EDKR/DKR

10.209-10.210

Profildichtringe/O-Ringe
Profile sealing rings/O-rings
Juntas anulares con perfil/Juntas tóricas



VDR/VOR

Technische Information

Schneidringverschraubungen

Technical information

Cutting ring fittings

Información técnica

Racores de anillo cortante

Eigenschaften, Besonderheiten

- nach ISO 8434-1/DIN 2353
- Baureihen LL, L und S
- korrosionsbeständig
- große Sortimentsvielfalt

Characteristics, specialties

- according to ISO 8434-1/DIN 2353
- series LL, L and S
- corrosion resistant
- large range of products

Características, particularidades

- según ISO 8434-1/DIN 2353
- series LL, L y S
- resistencia a la corrosión
- amplio surtido

Funktionsprinzip

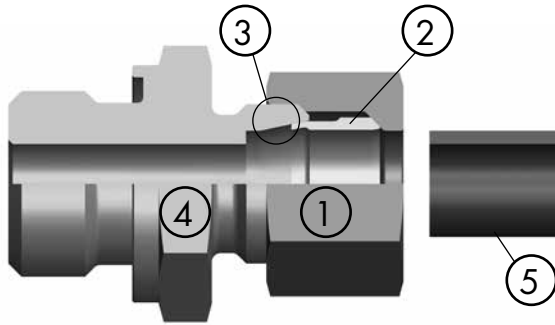

Vor der Montage
Before assembly
Antes del montaje

Operating principle

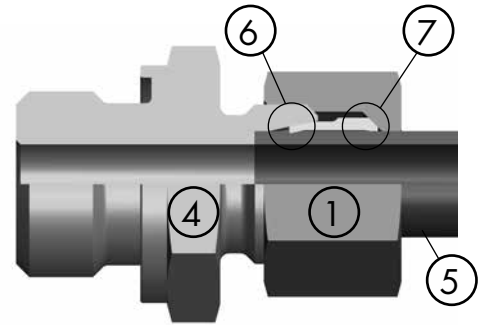

Nach der Montage
After assembly
Después del montaje

Die Überwurfmutter (1) presst den keilförmig vorgeformten Schneidring (2) beim Anziehen in den Innenkegel (3) des Verschraubungsstutzens (4).

On tightening the nut (1) the cutting ring (2) is pressed into the inner taper (3) of the connector (4) and into the tube (5).

Al apretar, la tuerca de unión (1) empuja el anillo de corte con forma de cuña (2) dentro del cono interior (3) del cuerpo (4).

Der Schneidring wird dadurch ringförmig auf das Rohr (5) gepresst, so dass die gehärtete Schneidkante (6) des Schneidringes gleichförmig in das Rohr einschneidet. Dadurch wirft sich ein ringförmiger Bundaufwurf des Rohrmaterials vor der Schneidkante auf.

The cutting ring is pressed annularly on the tube (5) so that the hardened cutting edge (6) of the cutting ring cuts uniformly into the tube. This forms a circumferential bead of the tube material in front of the cutting edge.

En esta operación, el anillo cortante ataca el tubo (5) en toda la circunferencia de forma que el filo templado (6) del anillo realiza un corte homogéneo en el mismo y levanta un reborde anular de material delante del filo.

Die konstruktive Formgebung des Schneidringes begrenzt die Eindringtiefe. Gleichzeitig verkeilt sich der Schneidring mutternseitig auf dem Rohr (7) und bietet so zusätzlichen Halt und Entlastung der Schneidzone bei dynamischer Beanspruchung. Formschluss und Kraftschluss des Schneidringesystems gewähren einen sicheren Halt der Rohrverbindungen.

The design form of the cutting ring determines the cut-in depth. A tapered nut/cutting ring interface results in the cutting ring being pressed into the tube (7), thereby providing additional support and relief to the cut-in zone under dynamic load conditions. The mechanical and frictional principle of the cutting ring system guarantees a secure tube connection.

El diseño constructivo del anillo de corte limita la profundidad de penetración. Al mismo tiempo, el anillo de corte se enclava en el tubo en el lado de la tuerca (7) y brinda fijación y descarga adicional en la zona de corte para esfuerzos dinámicos. La unión positiva y no positiva del sistema de anillo de corte garantiza la fijación segura de las uniones de tubos.

Werkstoff

Edelstahl 1.4571
Legierung X 6 CrNiMoTi 17 12 2
≈ AISI 316 Ti
Andere hochwertige Werkstoffqualitäten (Hastelloy®, Monel®, Titan, etc.) sind möglich.

Material

Stainless steel 1.4571
alloy X 6 CrNiMoTi 17 12 2
≈ AISI 316 Ti
Other high quality materials (Hastelloy®, Monel®, Titan, etc.) also available.

Material

Acero inoxidable 1.4571
aleación X 6 CrNiMoTi 17 12 2
≈ AISI 316 Ti
Otras materiales de alta calidad (Hastelloy®, Monel®, titanio, etc.) están disponibles.

Nenndruck PN

bis 800 bar gemäß DNV GL

Pressure nominal PN

up to 800 bar according to DNV GL

Presión nominal PN

hasta 800 bar según DNV GL

Technische Information

Schneidringverschraubungen (Fort.)

Technical information

Cutting ring fittings (cont.)

Información técnica

Racores de anillo cortante (cont.)

Druckbereiche für Schneidringverschraubungen

Baureihe	Rohr	Nenndruck
LL: sehr leicht	4 - 12 mm	PN 100 (bar)
L: leicht	6 - 10 mm	PN 500 (bar)
	12 - 18 mm	PN 400 (bar)
	22 - 42 mm	PN 250 (bar)
S: schwer	6 - 10 mm	PN 800 (bar)
	12 - 16 mm	PN 630 (bar)
	20 - 38 mm	PN 420 (bar)

Pressure range for Cutting ring fittings

Serie	Tube	Pressure nom.
LL: extra light	4 - 12 mm	PN 100 (bar)
L: light	6 - 10 mm	PN 500 (bar)
	12 - 18 mm	PN 400 (bar)
	22 - 42 mm	PN 250 (bar)
S: heavy	6 - 10 mm	PN 800 (bar)
	12 - 16 mm	PN 630 (bar)
	20 - 38 mm	PN 420 (bar)

Rangos de presión para Racores de anillo cortante

Serie	Tubo	Presión nom.
LL: muy ligera	4 - 12 mm	PN 100 (bar)
L: ligera	6 - 10 mm	PN 500 (bar)
	12 - 18 mm	PN 400 (bar)
	22 - 42 mm	PN 250 (bar)
S: pesada	6 - 10 mm	PN 800 (bar)
	12 - 16 mm	PN 630 (bar)
	20 - 38 mm	PN 420 (bar)

Druckauswertungsgrad in % des PN

Pressure coefficient in % of PN

Grado de valoración de presión en % de la PN

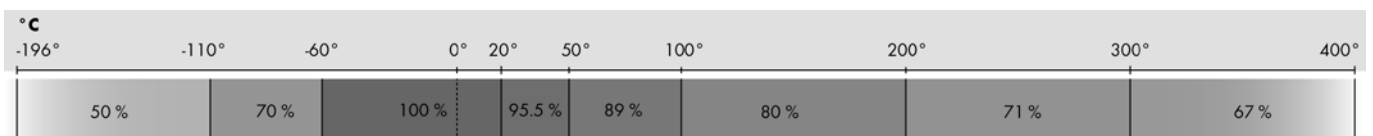

Temperaturbereich

-196 °C bis +400 °C

Achtung: Ausnahmen bilden weichgedichtete (Zusatz "WD") oder Dichtkegel-Verschraubungen (Zusatz "KO"), die nur in einem Bereich von -20 °C bis +200 °C eingesetzt werden können.

Temperature range

-196 °C to +400 °C

Attention: Excepted are FKM-sealed fittings (suppl. "WD") and fittings with taper (suppl. "KO"), which can be used only in a range from -20 °C up to +200 °C.

Intervalo de temperatura

de -196 °C a +400 °C

Atención: La excepción son los racores con juntas blandas (código "WD") o de junta cónica (código "KO"), aptos solo para un rango de temperaturas de -20 °C hasta +200 °C.

Helium-Leckrate

mind. 10⁻⁶ mbar • l/s bei fachgerechter Montage; siehe Kapitel i für Montageanleitung.

Helium leak rate

10⁻⁶ mbar • l/s min. when professionally assembled; see chapter i for installation instructions.

Tasa de fuga de helio

mín. 10⁻⁶ mbar • l/s con montaje correcto; para las instrucciones de montaje, consulte el capítulo i.

Vakuum

bis 10⁻⁴ mbar, höhere Werte möglich

Vacuum

up to 10⁻⁴ mbar, higher values are possible

Vacío

hasta 10⁻⁴ mbar; posibilidad de valores superiores

Anzuschließende Rohre

Nahtlose, gezogene Präzisionsrohre aus Edelstahl (DIN EN 10216-5/EN ISO 1127, Toleranzkl. D4/T3) mit sauberer, glatter Oberfläche oder Kunststoffrohre. Außendurchmesser innerhalb ± 0,1 mm; Ausnahme: Kunststoffrohre. Siehe auch Kapitel Rohre und Schläuche. Weitere Materialien auf Anfrage.

Tubes to use

Seamless, cold-drawn, high precision stainless steel tubes (according to DIN EN 10216-5/EN ISO 1127 tolerance class D4/T3) with clean, smooth surface or plastic tubes. Outer diameter within ± 0,1 mm; exception: plastic tubes. See also chapter tubes and hoses. Other materials on request.

Tubos para conectar

Tubos de precisión estirados sin costuras, de acero inoxidable (DIN EN 10216-5/EN ISO 1127, clase de tolerancia D4/T3) con superficie lisa limpia o tubos de plástico. Diámetro exterior con tolerancia de ± 0,1 mm; excepción: tubos de plástico. Véase también el capítulo Tubos y mangueras. Otros materiales bajo demanda.

Werkzeugnis

Werden Bescheinigungen über Materialprüfungen nach DIN EN 10 204 gewünscht, so ist dies bei Bestellung anzugeben (Abnahmeprüfung gegen Berechnung).

Material certificates

Inform us with your order if you need material testing certificates according to DIN EN 10204 (charges apply to inspection certificates 3.1).

Certificado de material

Si se necesitan certificados de ensayos de material según DIN EN 10 204, deberá especificarse al realizar el pedido (se facturará a partir del certificado de recepción 3.1).

Zulassungen

DNV GL, ABS, LR, BV, CCS, RMRS. Weitere Informationen auf Anfrage.

Approvals

DNV GL, ABS, LR, BV, CCS, RMRS. Further information on request.

Homologaciones

DNV GL, ABS, LR, BV, CCS, RMRS. Más información bajo demanda.

Technische Information

Dichtkegelverschraubungen

Technical information

Tapered seal fittings

Información técnica

Racores cónicos

Baumaße

- Baumaße entsprechend Verschraubungen nach DIN 2353 und ISO 8434-1
- passend für alle Gewindestutzen mit 24° Innenkonen (Bohrungsform W DIN 3861)

Dicht- und Halteprinzip

Bei den EXMAR Dichtkegelverschraubungen ist die Überwurfmutter drehbar auf den Stutzen montiert. Durch den zusätzlich im Kegel eingelegten O-Ring kommt eine metallisch/elastomere Abdichtung zustande, die eine hohe Leckagesicherheit gewährleistet.

Vorteile

- richtungseinstellbar durch drehbare Überwurfmutter
- einfache und schnelle Montage durch fixierten Anzugsweg mit geringem Drehmoment
- hohe Belastbarkeit bei Druckschwankungen und Schwingungen im System

Druckbereiche für

Dichtkegelverschraubungen

Baureihe	Rohr	Nenndruck
L: leicht	6 - 18 mm	PN 315 (bar)
	22 - 42 mm	PN 160 (bar)
S: schwer	6 - 14 mm	PN 630 (bar)
	16 - 30 mm	PN 400 (bar)
	38 mm	PN 315 (bar)

Temperaturbereich

-20°C bis +200°C

Dichtungsmaterial FKM (andere Werkstoffe auf Anfrage)

Dimensions

- dimensions are consistent with DIN 2353 and ISO 8434 fittings
- compatible with all threaded connectors according to DIN 3858 with 24° inner cones (bore form W DIN 3861)

Sealing and fastening principle

On the EXMAR tapered seal fittings, a rotatable nut is mounted on the connector. With the additional O-ring in the cone, a metal/elastomer seal is created that guarantees leak-tightness.

Benefits

- direction adjustable with the rotatable nut
- easy and fast assembly due to fixed tightening procedure with low torque
- highly resilient against pressure fluctuation and vibration in the system

Pressure range for

Tapered seal fittings

Serie	Tube	Pressure nom.
L: light	6 - 18 mm	PN 315 (bar)
	22 - 42 mm	PN 160 (bar)
S: heavy	6 - 14 mm	PN 630 (bar)
	16 - 30 mm	PN 400 (bar)
	38 mm	PN 315 (bar)

Temperature range

-20°C to +200°C

Sealing material: FKM (other materials on request)

Medidas

- medidas corresponden a los racores según DIN 2353 e ISO 8434
- aptos para todos los racores roscados según DIN 3858 con conos interiores de 24° (forma de taladro W DIN 3861)

Principio de obturación y fijación

En el racor de junta cónica EXMAR, la tuerca de unión está enroscada en el racor. La junta tórica adicional integrada en el cono forma un cierre hermético metálico/elastomérico que garantiza un alto grado de estanquidad.

Ventajas

- dirección ajustable mediante la tuerca de unión giratoria
- montaje fácil y rápido mediante carrera de apriete fijada con par bajo
- alta capacidad de carga para variaciones de presión y vibraciones en el sistema

Rangos de presión para

Racores cónicos

Serie	Tubo	Presión nom.
L: ligera	6 - 18 mm	PN 315 (bar)
	22 - 42 mm	PN 160 (bar)
S: pesada	6 - 14 mm	PN 630 (bar)
	16 - 30 mm	PN 400 (bar)
	38 mm	PN 315 (bar)

Rango de temperatura

-20°C hasta +200°C

Material de junta tórica: FKM (otros materiales bajo demanda)

Technische Information

Dichtkegelverschraubungen (Fort.)

Technical information

Tapered seal fittings (cont.)

Información técnica

Racores cónicos(cont.)

Einstellbare Verschraubung mit Dichtkegel und O-Ring

Adjustable fittings with taper and O-ring

Racores ajustable con junta cónica y junta tórica

EGKO

Gerade Einschraubstutzen
Straight male adaptor unions
Racores para rosca rectos

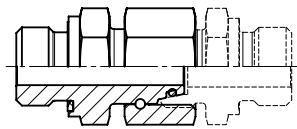

VKO

Gerade Zwischenstutzen
Straight unions
Racores de unión rectos

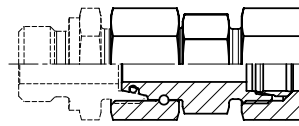
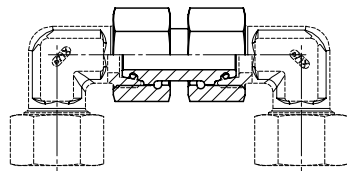

GKO

Gerade Verschraubungen
Straight fittings
Racores rectos

VKOR

Gerade Zwischenreduzierstutzen
Straight reducing unions
Racores de reducción rectos

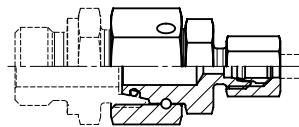
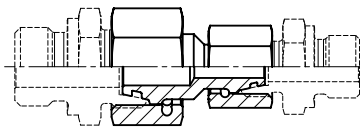

GRKO

Reduzierschraubungen
Reducing fittings
Racores de reducción

EWKO

Einstellbare Winkelverschraubungen
Adjustable elbow fittings
Racores angulares ajustables

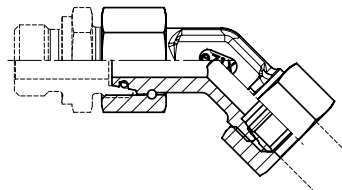
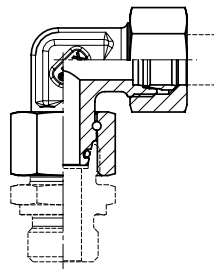

EWKO 45°

Einstellbare Winkelverschraubungen 45°
Adjustable elbow fittings 45°
Racores angulares ajustables 45°

ETKO

Einstellbare T-Verschraubungen
Adjustable T fittings
Racores T ajustables

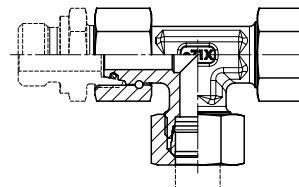
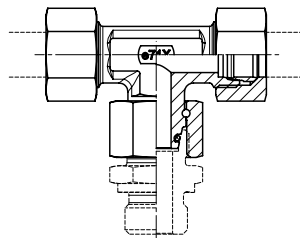

ELKO

Einstellbare L-Verschraubungen
Adjustable L fittings
Racores L ajustables

Gerade Stutzen
Straight connectors
Cuerpos rectos

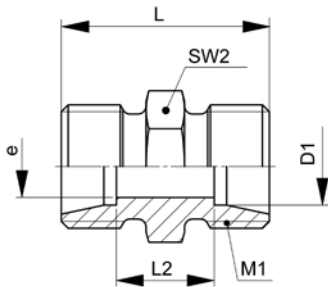

XGV-..L/S

Type -D1	Mat.-Nr.	PN	M1	L	L2	SW2	e	g/Stk
XGV-04LL	706.1020.040.10	100	8x1.0	20.0	12.0	9	3.0	6
XGV-06LL	706.1020.060.10	100	10x1.0	20.0	9.0	11	4.5	8
XGV-08LL	706.1020.080.10	100	12x1.0	23.0	12.0	12	6.0	12
XGV-10LL	706.1020.100.10	100	14x1.0	23.0	12.0	14	8.0	15
XGV-06L	706.1020.060.20	500	12x1.5	24.0	10.0	12	4.0	15
XGV-08L	706.1020.080.20	500	14x1.5	25.0	11.0	14	6.0	19
XGV-10L	706.1020.100.20	500	16x1.5	27.0	13.0	17	8.0	26
XGV-12L	706.1020.120.20	400	18x1.5	28.0	14.0	19	10.0	32
XGV-15L	706.1020.150.20	400	22x1.5	30.0	16.0	24	12.0	50
XGV-18L	706.1020.180.20	400	26x1.5	31.0	16.0	27	15.0	74
XGV-22L	706.1020.220.20	250	30x2.0	35.0	20.0	32	19.0	101
XGV-28L	706.1020.280.20	250	36x2.0	36.0	21.0	41	24.0	151
XGV-35L	706.1020.350.20	250	45x2.0	41.0	20.0	46	32.0	225
XGV-42L	706.1020.420.20	250	52x2.0	43.0	21.0	55	36.0	320
XGV-06S	706.1020.060.30	800	14x1.5	30.0	16.0	14	4.0	29
XGV-08S	706.1020.080.30	800	16x1.5	32.0	18.0	17	5.0	41
XGV-10S	706.1020.100.30	800	18x1.5	32.0	17.0	19	7.0	48
XGV-12S	706.1020.120.30	630	20x1.5	34.0	19.0	22	8.0	65
XGV-14S	706.1020.140.30	630	22x1.5	38.0	22.0	24	10.0	83
XGV-16S	706.1020.160.30	630	24x1.5	38.0	21.0	27	12.0	95
XGV-20S	706.1020.200.30	420	30x2.0	44.0	23.0	32	16.0	157
XGV-25S	706.1020.250.30	420	36x2.0	50.0	26.0	41	20.0	271
XGV-30S	706.1020.300.30	420	42x2.0	54.0	27.0	46	25.0	357
XGV-38S	706.1020.380.30	420	52x2.0	61.0	29.0	55	32.0	580

ISO 8434-1-5

D1=Rohr außen-Ø
M1=metrisches Anschlußgewinde
e=kleinster Innen-Ø

D1=tube outside diameter
M1=metric connecting thread
e=minimum inside diameter

D1=Ø exterior del tubo
M1=rosca métrica conexión
e=Ø interior mínimo

Gerade Verschraubungen

Straight fittings

Racores rectos

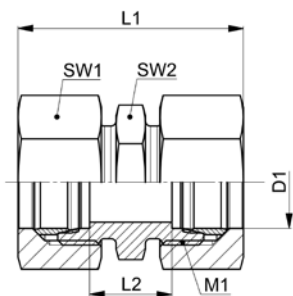

10

GV..L/S

Type -D1	Mat.-Nr.	PN	M1	L1	L2	SW1	SW2	g/Stk
GV-04LL	708.1020.040.10	100	8x1.0	32.0	12.0	10	9	15
GV-06LL	708.1020.060.10	100	10x1.0	32.0	9.0	12	11	20
GV-08LL	708.1020.080.10	100	12x1.0	36.0	12.0	14	12	26
GV-10LL	708.1020.100.10	100	14x1.0	36.0	12.0	17	14	43
GV-06L	708.1020.060.20	500	12x1.5	40.0	10.0	14	12	35
GV-08L	708.1020.080.20	500	14x1.5	41.0	11.0	17	14	50
GV-10L	708.1020.100.20	500	16x1.5	44.0	13.0	19	17	65
GV-12L	708.1020.120.20	400	18x1.5	45.0	14.0	22	19	85
GV-15L	708.1020.150.20	400	22x1.5	48.0	16.0	27	24	140
GV-18L	708.1020.180.20	400	26x1.5	50.0	16.0	32	27	201
GV-22L	708.1020.220.20	250	30x2.0	54.0	20.0	36	32	274
GV-28L	708.1020.280.20	250	36x2.0	55.0	21.0	41	41	347
GV-35L	708.1020.350.20	250	45x2.0	65.5	20.0	50	46	543
GV-42L	708.1020.420.20	250	52x2.0	68.0	21.0	60	55	790
GV-06S	708.1020.060.30	800	14x1.5	46.0	16.0	17	14	65
GV-08S	708.1020.080.30	800	16x1.5	48.0	18.0	19	17	83
GV-10S	708.1020.100.30	800	18x1.5	51.0	17.0	22	19	110
GV-12S	708.1020.120.30	630	20x1.5	53.0	19.0	24	22	135
GV-14S	708.1020.140.30	630	22x1.5	59.0	22.0	27	24	187
GV-16S	708.1020.160.30	630	24x1.5	60.0	21.0	30	27	229
GV-20S	708.1020.200.30	420	30x2.0	69.0	23.0	36	32	371
GV-25S	708.1020.250.30	420	36x2.0	77.0	26.0	46	41	672
GV-30S	708.1020.300.30	420	42x2.0	83.0	27.0	50	46	821
GV-38S	708.1020.380.30	420	52x2.0	95.0	29.0	60	55	1215

Baumaße sind Ungefährmaße bei angezogener Überwurfmutter.

Sizes are approximate dimensions at tightened nut.

Las medidas son aproximadas con la tuerca de unión apretada.

ISO 8434-1-SC

D1=Rohr außen-Ø
M1=metrisches Anschlußgewinde

D1=tube outside diameter
M1=metric connecting thread

D1=Ø exterior del tubo
M1=rosca métrica conexión

Gerade Stutzen mit Dichtkegel und O-Ring

dichtkegelseitig vormontiert

Straight connectors with taper and O-ring

pre-assembled on tapered nipple side

Cuerpos rectos con junta cónica y junta tórica

premontado en lado de junta cónica

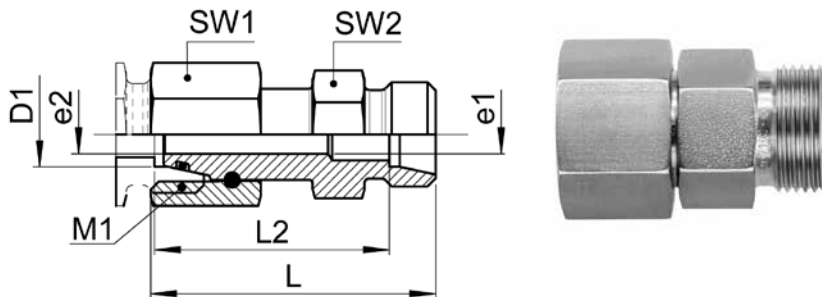

XGKO-..L M

Type-D1	Mat.-Nr.	PN	M1	L	L2	SW1	SW2	e1	e2	g/Stk
XGKO-06L M	707.1050.060.20	315	12x1.5	43.0	36.0	14	12	2.5	4.0	33
XGKO-08L M	707.1050.080.20	315	14x1.5	43.0	36.0	17	14	4.0	6.0	44
XGKO-10L M	707.1050.100.20	315	16x1.5	43.0	36.0	19	17	6.0	8.0	57
XGKO-12L M	707.1050.120.20	315	18x1.5	43.0	36.0	22	19	8.0	8.0	70
XGKO-15L M	707.1050.150.20	315	22x1.5	43.0	36.0	27	24	10.0	10.0	125
XGKO-18L M	707.1050.180.20	315	26x1.5	43.5	36.0	32	27	13.0	15.0	156
XGKO-22L M	707.1050.220.20	160	30x2.0	47.5	40.0	36	32	17.0	17.0	227
XGKO-28L M	707.1050.280.20	160	36x2.0	47.5	40.0	41	41	22.0	22.0	366
XGKO-35L M	707.1050.350.20	160	45x2.0	60.5	50.0	50	46	28.0	30.0	450
XGKO-42L M	707.1050.420.20	160	52x2.0	71.0	60.0	60	55	34.0	36.0	735

Dichtungsmaterial: FKM (andere Werkstoffe auf Anfrage)

Sealing material: FKM (other materials on request)

Material de junta tórica: FKM (otros materiales bajo demanda)

D1=Rohr außen-Ø
M1=metrisches Anschlußgewinde
e=kleinster Innen-Ø

D1=tube outside diameter
M1=metric connecting thread
e=minimum inside diameter

D1=Ø exterior del tubo
M1=rosca métrica conexión
e=Ø interior mínimo

Gerade Verschraubungen mit Dichtkegel und O-Ring
Straight fittings with taper and O-ring
Racores rectos con junta cónica y junta tórica

10

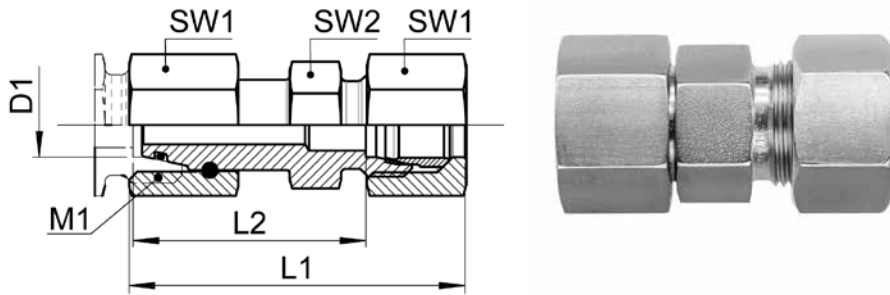

GKO-..L

Type -D1	Mat.-Nr.	PN	M1	L1	L2	SW1	SW2	g/Stk
GKO-06L	708.1050.060.20	315	12x1.5	51.5	36.0	14	12	44
GKO-08L	708.1050.080.20	315	14x1.5	51.5	36.0	17	14	62
GKO-10L	708.1050.100.20	315	16x1.5	51.5	36.0	19	17	79
GKO-12L	708.1050.120.20	315	18x1.5	51.5	36.0	22	19	98
GKO-15L	708.1050.150.20	315	22x1.5	51.5	36.0	27	24	170
GKO-18L	708.1050.180.20	315	26x1.5	52.5	36.0	32	27	224
GKO-22L	708.1050.220.20	160	30x2.0	56.5	40.0	36	32	317
GKO-28L	708.1050.280.20	160	36x2.0	57.0	40.0	41	41	465
GKO-35L	708.1050.350.20	160	45x2.0	72.0	50.0	50	46	620
GKO-42L	708.1050.420.20	160	52x2.0	83.0	60.0	60	55	1000

Baumaße sind Ungefährmaße bei angezogener Überwurfmutter.

Sizes are approximate dimensions at tightened nut.

Las medidas son aproximadas con la tuerca de unión apretada.

Dichtungsmaterial: FKM (andere Werkstoffe auf Anfrage)

Sealing material: FKM (other materials on request)

Material de junta tórica: FKM (otros materiales bajo demanda)

Gerade Zwischenstutzen mit Dichtkegel und O-Ring

Straight unions with taper and O-ring

Racores de unión rectos con junta cónica y junta tórica

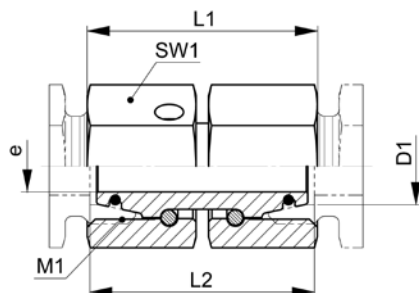

VKO-..L/S

Type -D1	Mat.-Nr.	PN	M1	L1	L2	SW1	e	g/Stk
VKO-06L	708.1070.060.21	315	12x1.5	34.0	33.0	17	3.0	48
VKO-08L	708.1070.080.21	315	14x1.5	34.0	33.0	17	4.0	42
VKO-10L	708.1070.100.21	315	16x1.5	36.0	34.0	19	6.0	56
VKO-12L	708.1070.120.21	315	18x1.5	35.0	34.0	22	8.0	78
VKO-15L	708.1070.150.21	315	22x1.5	43.0	39.0	27	10.0	128
VKO-18L	708.1070.180.21	315	26x1.5	37.0	38.0	32	13.0	182
VKO-22L	708.1070.220.21	160	30x2.0	48.0	44.0	36	17.0	254
VKO-28L	708.1070.280.21	160	36x2.0	54.0	48.0	41	23.0	440
VKO-35L	708.1070.350.21	160	45x2.0	54.0	52.0	50	28.0	486
VKO-42L	708.1070.420.21	160	52x2.0	59.0	57.0	60	34.0	712
VKO-06S	708.1070.060.31	630	14x1.5	34.0	33.0	17	3.0	44
VKO-08S	708.1070.080.31	630	16x1.5	35.0	34.0	19	4.0	60
VKO-10S	708.1070.100.31	630	18x1.5	35.0	35.0	22	6.0	84
VKO-12S	708.1070.120.31	630	20x1.5	37.0	38.0	24	8.0	110
VKO-14S	708.1070.140.31	630	22x1.5	43.0	41.0	27	9.0	142
VKO-16S	708.1070.160.31	400	24x1.5	43.0	42.0	30	10.0	182
VKO-20S	708.1070.200.31	400	30x2.0	49.0	48.0	36	13.0	300
VKO-25S	708.1070.250.31	400	36x2.0	53.0	53.0	46	18.0	481
VKO-30S	708.1070.300.31	400	42x2.0	58.0	62.0	50	20.0	646
VKO-38S	708.1070.380.31	315	52x2.0	60.0	67.0	60	28.0	936

Baumaße sind Ungefährmaße bei angezogener Überwurfmutter.

Sizes are approximate dimensions at tightened nut.

Las medidas son aproximadas con la tuerca de unión apretada.

Dichtungsmaterial: FKM (andere Werkstoffe auf Anfrage)

Sealing material: FKM (other materials on request)

Material de junta tórica: FKM (otros materiales bajo demanda)

D1=Rohr außen-Ø
M1=metrisches Anschlußgewinde
e=kleinster Innen-Ø

D1=tube outside diameter
M1=metric connecting thread
e=minimum inside diameter

D1=Ø exterior del tubo
M1=rosca métrica conexión
e=Ø interior mínimo

Schmieren der EXMAR-Verschraubungen

- EXMAR Muttern werden initialgeschmiert ausgeliefert, ideal für eine problemlose Vormontage
- unser verwendetes Schmiermittel erfüllt die strengen Auflagen der ISO 14001:2004
- für die Endmontage verwenden Sie bitte unsere Fettpaste ASW wie in der Montageanleitung empfohlen
- wir empfehlen das Einfetten von Konus und Gewinde des Stützens, des Schneid-/NC-Klemmringes und des Gewindes der Überwurfmutter
- unsere innenversilberten NC-Muttern können ohne Schmierung montiert werden
- Videos zu den Montageanleitungen finden Sie auf www.exmar.de

Lubrication of EXMAR fittings

- EXMAR nuts are delivered with initial lubrication, ideal for easy pre-assembly
- Our used lubricant meets the strict requirements of ISO 14001: 2004
- For final assembly please use our grease paste ASW as recommended in the assembly instructions
- We recommend greasing of 24° taper and thread of the connector, of the cutting / NC clamping ring and of the thread of the union nut
- Our internally silver-plated NC nuts can be installed without lubrication
- Assembly instruction videos on www.exmar.de

Lubricación del raccors EXMAR

- tuercas EXMAR se envían lubricación inicial, ideal para un premontaje fácil
- nuestro lubricante utilizado cumple con los estrictos requisitos de la norma ISO 14001: 2004
- para el montaje final por favor utilice nuestro ASW Grasa como se describe en las instrucciones de montaje recomendadas
- Se recomienda engrase de cono y la rosca del cuello, el anillo de apriete / NC de corte y de la rosca de la tuerca de unión
- nuestros plateadas interna tuercas NC se pueden montar sin lubricación
- encontrará los vídeos de las instrucciones de montaje en www.exmar.de



Winkelstutzen

Elbow connectors

Cuerpos codo

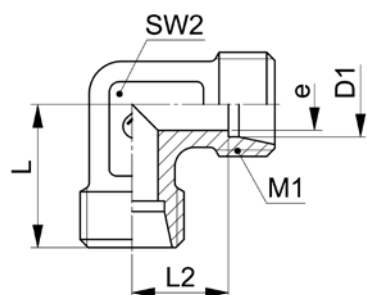

XWV-..L/S

Type -D1	Mat.-Nr.	PN	M1	L	L2	SW2	e	g/Stk
XWV-04LL	706.2000.040.10	100	8x1.0	15.0	11.0	9	3.0	9
XWV-06LL	706.2000.060.10	100	10x1.0	15.0	9.5	9	4.5	10
XWV-08LL	706.2000.080.10	100	12x1.0	18.5	13.0	12	6.0	18
XWV-06L	706.2000.060.20	500	12x1.5	19.0	12.0	12	4.0	23
XWV-08L	706.2000.080.20	500	14x1.5	21.0	14.0	12	6.0	26
XWV-10L	706.2000.100.20	500	16x1.5	22.0	15.0	14	8.0	33
XWV-12L	706.2000.120.20	400	18x1.5	24.0	17.0	17	10.0	48
XWV-15L	706.2000.150.20	400	22x1.5	28.0	21.0	19	12.0	83
XWV-18L	706.2000.180.20	400	26x1.5	31.0	23.5	24	15.0	122
XWV-22L	706.2000.220.20	250	30x2.0	35.0	27.5	27	19.0	165
XWV-28L	706.2000.280.20	250	36x2.0	38.0	30.5	36	24.0	265
XWV-35L	706.2000.350.20	250	45x2.0	45.0	34.5	41	30.0	402
XWV-42L	706.2000.420.20	250	52x2.0	51.0	40.0	50	36.0	632
XWV-06S	706.2000.060.30	800	14x1.5	23.0	16.0	12	4.0	37
XWV-08S	706.2000.080.30	800	16x1.5	24.0	17.0	14	5.0	53
XWV-10S	706.2000.100.30	800	18x1.5	25.0	17.5	17	7.0	66
XWV-12S	706.2000.120.30	630	20x1.5	29.0	21.5	17	8.0	89
XWV-14S	706.2000.140.30	630	22x1.5	30.0	22.0	19	10.0	106
XWV-16S	706.2000.160.30	630	24x1.5	33.0	24.5	24	12.0	151
XWV-20S	706.2000.200.30	420	30x2.0	37.0	26.5	27	16.0	218
XWV-25S	706.2000.250.30	420	36x2.0	42.0	30.0	36	20.0	378
XWV-30S	706.2000.300.30	420	42x2.0	49.0	35.5	41	25.0	571
XWV-38S	706.2000.380.30	420	52x2.0	57.0	41.0	50	32.0	911

ISO 8434-1-E

D1=Rohr außen-Ø
M1=metrisches Anschlußgewinde
e=kleinster Innen-Ø

D1=tube outside diameter
M1=metric connecting thread
e=minimum inside diameter

D1=Ø exterior del tubo
M1=rosca métrica conexión
e=Ø interior mínimo

Winkelverschraubungen

Elbow fittings

Racores codo

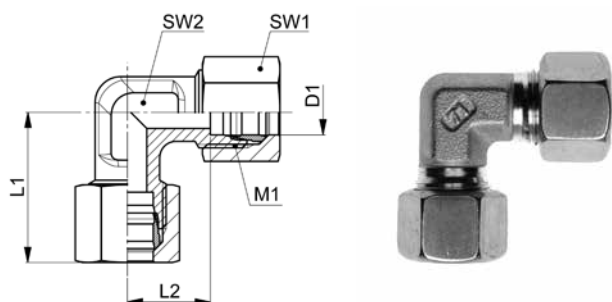

10

WV-..L/S

Type -D1	Mat.-Nr.	PN	M1	L1	L2	SW1	SW2	g/Stk
WV-04LL	708.2000.040.10	100	8x1.0	21.0	11.0	10	9	19
WV-06LL	708.2000.060.10	100	10x1.0	21.0	9.5	12	9	24
WV-08LL	708.2000.080.10	100	12x1.0	25.0	13.0	14	12	32
WV-06L	708.2000.060.20	500	12x1.5	27.0	12.0	14	12	42
WV-08L	708.2000.080.20	500	14x1.5	29.0	14.0	17	12	59
WV-10L	708.2000.100.20	500	16x1.5	30.5	15.0	19	14	74
WV-12L	708.2000.120.20	400	18x1.5	32.5	17.0	22	17	103
WV-15L	708.2000.150.20	400	22x1.5	37.0	21.0	27	19	169
WV-18L	708.2000.180.20	400	26x1.5	40.5	23.5	32	24	248
WV-22L	708.2000.220.20	250	30x2.0	44.5	27.5	36	27	320
WV-28L	708.2000.280.20	250	36x2.0	47.5	30.5	41	36	454
WV-35L	708.2000.350.20	250	45x2.0	57.0	34.5	50	41	675
WV-42L	708.2000.420.20	250	52x2.0	63.5	40.0	60	50	1070
WV-06S	708.2000.060.30	800	14x1.5	31.0	16.0	17	12	74
WV-08S	708.2000.080.30	800	16x1.5	32.0	17.0	19	14	95
WV-10S	708.2000.100.30	800	18x1.5	34.5	17.5	22	17	128
WV-12S	708.2000.120.30	630	20x1.5	38.5	21.5	24	17	159
WV-14S	708.2000.140.30	630	22x1.5	40.5	22.0	27	19	210
WV-16S	708.2000.160.30	630	24x1.5	44.0	24.5	30	24	260
WV-20S	708.2000.200.30	420	30x2.0	49.5	26.5	36	27	410
WV-25S	708.2000.250.30	420	36x2.0	55.5	30.0	46	36	776
WV-30S	708.2000.300.30	420	42x2.0	63.5	35.5	50	41	1003
WV-38S	708.2000.380.30	420	52x2.0	74.0	41.0	60	50	1535

Baumaße sind Ungefährmaße bei angezogener Überwurfmutter.

Sizes are approximate dimensions at tightened nut.

Las medidas son aproximadas con la tuerca de unión apretada.

ISO 8434-1-EC

D1=Rohr außen-Ø
M1=metrisches Anschlußgewinde

D1=tube outside diameter
M1=metric connecting thread

D1=Ø exterior del tubo
M1=rosca métrica conexión

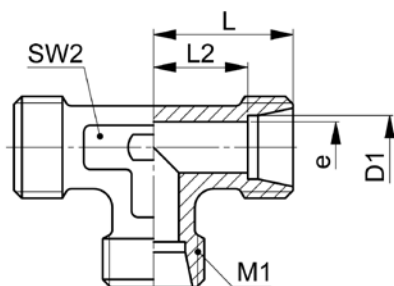
T-Stutzen
T connectors
Cuerpos T

XTV-..L/S

Type -D1	Mat.-Nr.	PN	M1	L	L2	SW2	e	g/Stk
XTV-04LL	706.3000.040.10	100	8x1.0	15.0	11.0	9	3.0	13
XTV-06LL	706.3000.060.10	100	10x1.0	15.0	9.5	9	4.5	14
XTV-08LL	706.3000.080.10	100	12x1.0	17.0	11.5	12	6.0	22
XTV-06L	706.3000.060.20	500	12x1.5	19.0	12.0	12	4.0	32
XTV-08L	706.3000.080.20	500	14x1.5	21.0	14.0	12	6.0	37
XTV-10L	706.3000.100.20	500	16x1.5	22.0	15.0	14	8.0	47
XTV-12L	706.3000.120.20	400	18x1.5	24.0	17.0	17	10.0	63
XTV-15L	706.3000.150.20	400	22x1.5	28.0	21.0	19	12.0	111
XTV-18L	706.3000.180.20	400	26x1.5	31.0	23.5	24	15.0	160
XTV-22L	706.3000.220.20	250	30x2.0	35.0	27.5	27	19.0	222
XTV-28L	706.3000.280.20	250	36x2.0	38.0	30.5	36	24.0	359
XTV-35L	706.3000.350.20	250	45x2.0	45.0	34.5	41	32.0	534
XTV-42L	706.3000.420.20	250	52x2.0	51.0	40.0	50	36.0	806
XTV-06S	706.3000.060.30	800	14x1.5	23.0	16.0	12	4.0	53
XTV-08S	706.3000.080.30	800	16x1.5	24.0	17.0	14	5.0	71
XTV-10S	706.3000.100.30	800	18x1.5	25.0	17.5	17	7.0	88
XTV-12S	706.3000.120.30	630	20x1.5	29.0	21.5	17	8.0	121
XTV-14S	706.3000.140.30	630	22x1.5	30.0	22.0	19	10.0	143
XTV-16S	706.3000.160.30	630	24x1.5	33.0	24.5	24	12.0	197
XTV-20S	706.3000.200.30	420	30x2.0	37.0	26.5	27	16.0	294
XTV-25S	706.3000.250.30	420	36x2.0	42.0	30.0	36	20.0	512
XTV-30S	706.3000.300.30	420	42x2.0	49.0	35.5	41	25.0	765
XTV-38S	706.3000.380.30	420	52x2.0	57.0	41.0	50	32.0	1188

ISO 8434-1-T

D1=Rohr außen-Ø
 M1=metrisches Anschlußgewinde
 e=kleinster Innen-Ø

D1=tube outside diameter
 M1=metric connecting thread
 e=minimum inside diameter

D1=Ø exterior del tubo
 M1=rosca métrica conexión
 e=Ø interior mínimo

T-Verschraubungen

T fittings

Racores T

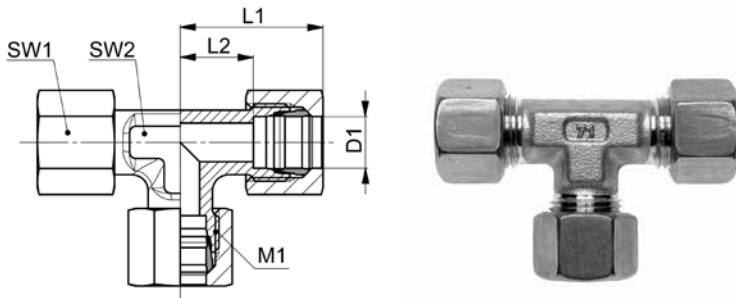

10

TV-..L/S

Type -D1	Mat.-Nr.	PN	M1	L1	L2	SW1	SW2	g/Stk
TV-04LL	708.3000.040.10	100	8x1.0	21.0	11.0	10	9	27
TV-06LL	708.3000.060.10	100	10x1.0	21.0	9.5	12	9	34
TV-08LL	708.3000.080.10	100	12x1.0	23.5	11.5	14	12	39
TV-06L	708.3000.060.20	500	12x1.5	27.0	12.0	14	12	51
TV-08L	708.3000.080.20	500	14x1.5	29.0	14.0	17	12	85
TV-10L	708.3000.100.20	500	16x1.5	30.5	15.0	19	14	106
TV-12L	708.3000.120.20	400	18x1.5	32.5	17.0	22	17	140
TV-15L	708.3000.150.20	400	22x1.5	37.0	21.0	27	19	240
TV-18L	708.3000.180.20	400	26x1.5	40.5	23.5	32	24	348
TV-22L	708.3000.220.20	250	30x2.0	44.5	27.5	36	27	468
TV-28L	708.3000.280.20	250	36x2.0	47.5	30.5	41	36	665
TV-35L	708.3000.350.20	250	45x2.0	57.0	34.5	50	41	1025
TV-42L	708.3000.420.20	250	52x2.0	63.5	40.0	60	50	1500
TV-06S	708.3000.060.30	800	14x1.5	31.0	16.0	17	12	110
TV-08S	708.3000.080.30	800	16x1.5	32.0	17.0	19	14	134
TV-10S	708.3000.100.30	800	18x1.5	34.5	17.5	22	17	190
TV-12S	708.3000.120.30	630	20x1.5	38.5	21.5	24	17	227
TV-14S	708.3000.140.30	630	22x1.5	40.5	22.0	27	19	300
TV-16S	708.3000.160.30	630	24x1.5	44.0	24.5	30	24	390
TV-20S	708.3000.200.30	420	30x2.0	49.5	26.5	36	27	590
TV-25S	708.3000.250.30	420	36x2.0	55.5	30.0	46	36	1180
TV-30S	708.3000.300.30	420	42x2.0	63.5	35.5	50	41	1430
TV-38S	708.3000.380.30	420	52x2.0	74.0	41.0	60	50	2010

Baumaße sind Ungefährmaße bei angezogener Überwurfmutter.

Sizes are approximate dimensions at tightened nut.

Las medidas son aproximadas con la tuerca de unión apretada.

ISO 8434-1-TC

D1=Rohr außen-Ø
M1=metrisches Anschlußgewinde

D1=tube outside diameter
M1=metric connecting thread

D1=Ø exterior del tubo
M1=rosca métrica conexión

Kreuz-Stutzen
Cross connectors
Cuerpos en cruz

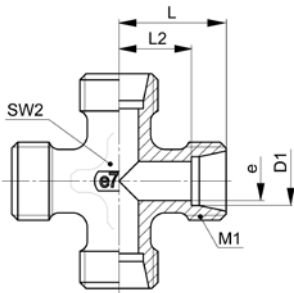

XKV-..L/S

Type -D1	Mat.-Nr.	PN	M1	L	L2	SW2	e	g/Stk
XKV-06L	706.4000.060.20	500	12x1.5	38.0	12.0	12	4.0	40
XKV-08L	706.4000.080.20	500	14x1.5	42.0	14.0	12	6.0	51
XKV-10L	706.4000.100.20	500	16x1.5	44.0	15.0	14	8.0	59
XKV-12L	706.4000.120.20	400	18x1.5	48.0	17.0	17	10.0	80
XKV-15L	706.4000.150.20	400	22x1.5	56.0	21.0	19	12.0	133
XKV-18L	706.4000.180.20	400	26x1.5	62.0	23.5	24	15.0	220
XKV-22L	706.4000.220.20	250	30x2.0	70.0	27.5	27	19.0	261
XKV-28L	706.4000.280.20	250	36x2.0	76.0	30.5	36	24.0	425
XKV-35L	706.4000.350.20	250	45x2.0	90.0	34.5	41	30.0	699
XKV-42L	706.4000.420.20	250	52x2.0	102.0	40.0	50	36.0	959
XKV-06S	706.4000.060.30	800	14x1.5	46.0	16.0	12	4.0	72
XKV-08S	706.4000.080.30	800	16x1.5	48.0	17.0	14	5.0	91
XKV-10S	706.4000.100.30	800	18x1.5	50.0	17.5	17	7.0	112
XKV-12S	706.4000.120.30	630	20x1.5	58.0	21.5	17	8.0	150
XKV-14S	706.4000.140.30	630	22x1.5	60.0	22.0	19	10.0	174
XKV-16S	706.4000.160.30	630	24x1.5	66.0	24.5	24	12.0	267
XKV-20S	706.4000.200.30	420	30x2.0	74.0	26.5	27	16.0	352
XKV-25S	706.4000.250.30	420	36x2.0	84.0	30.0	36	20.0	618
XKV-30S	706.4000.300.30	420	42x2.0	98.0	35.5	41	25.0	965
XKV-38S	706.4000.380.30	420	52x2.0	114.0	41.0	50	32.0	1444

ISO 8434-1-K

D1=Rohr außen-Ø
M1=metrisches Anschlußgewinde
e=kleinster Innen-Ø

D1=tube outside diameter
M1=metric connecting thread
e=minimum inside diameter

D1=Ø exterior del tubo
M1=rosca métrica conexión
e=Ø interior mínimo

Kreuz-Verschraubungen
Cross fittings
Racores en cruz

10

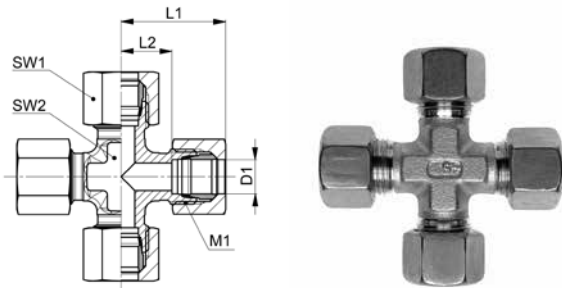

KV-..L/S

Type -D1	Mat.-Nr.	PN	M1	L1	L2	SW1	SW2	g/Stk
KV-06L	708.4000.060.20	500	12x1.5	27.0	12.0	14	12	80
KV-08L	708.4000.080.20	500	14x1.5	29.0	14.0	17	12	109
KV-10L	708.4000.100.20	500	16x1.5	30.0	15.0	19	14	158
KV-12L	708.4000.120.20	400	18x1.5	32.0	17.0	22	17	185
KV-15L	708.4000.150.20	400	22x1.5	36.0	21.0	27	19	338
KV-18L	708.4000.180.20	400	26x1.5	40.0	23.5	32	24	445
KV-22L	708.4000.220.20	250	30x2.0	44.0	27.5	36	27	600
KV-28L	708.4000.280.20	250	36x2.0	47.0	30.5	41	36	810
KV-35L	708.4000.350.20	250	45x2.0	56.0	34.5	50	41	1250
KV-42L	708.4000.420.20	250	52x2.0	63.5	40.0	60	50	1880
KV-06S	708.4000.060.30	800	14x1.5	31.0	16.0	17	12	140
KV-08S	708.4000.080.30	800	16x1.5	32.0	17.0	19	14	175
KV-10S	708.4000.100.30	800	18x1.5	34.0	17.5	22	17	235
KV-12S	708.4000.120.30	630	20x1.5	38.0	21.5	24	17	315
KV-14S	708.4000.140.30	630	22x1.5	40.0	22.0	27	19	385
KV-16S	708.4000.160.30	630	24x1.5	43.0	24.5	30	24	500
KV-20S	708.4000.200.30	420	30x2.0	48.0	26.5	36	27	857
KV-25S	708.4000.250.30	420	36x2.0	54.0	30.0	46	36	1250
KV-30S	708.4000.300.30	420	42x2.0	62.0	35.5	50	41	1540
KV-38S	708.4000.380.30	420	52x2.0	72.0	41.0	60	50	2900

Baumaße sind Ungefährmaße bei angezogener Überwurfmutter.

Sizes are approximate dimensions at tightened nut.

Las medidas son aproximadas con la tuerca de unión apretada.

ISO 8434-1-KC

D1=Rohr außen-Ø
M1=metrisches Anschlußgewinde

D1=tube outside diameter
M1=metric connecting thread

D1=Ø exterior del tubo
M1=rosca métrica conexión

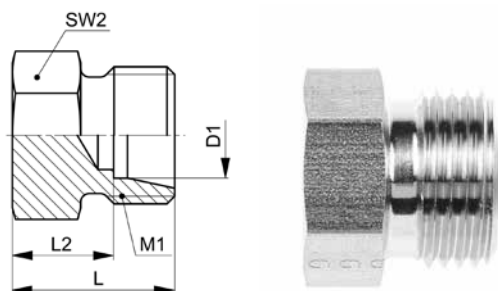
Verschlussstutzen
Locking connectors
Cuerpos de cierre

XVSA-..L/S

Type -D1	Mat.-Nr.	PN	M1	L	L2	SW2	g/Stk
XVSA-06L	706.1205.060.20	500	12x1.5	16.0	15.0	12	11
XVSA-08L	706.1205.080.20	500	14x1.5	18.0	15.0	14	14
XVSA-10L	706.1205.100.20	500	16x1.5	19.0	15.5	17	25
XVSA-12L	706.1205.120.20	500	18x1.5	19.0	15.5	19	30
XVSA-15L	706.1205.150.20	500	22x1.5	22.0	16.0	24	59
XVSA-18L	706.1205.180.20	500	26x1.5	22.0	17.0	27	75
XVSA-22L	706.1205.220.20	250	30x2.0	26.0	17.0	32	122
XVSA-28L	706.1205.280.20	250	36x2.0	26.0	17.0	41	187
XVSA-35L	706.1205.350.20	250	45x2.0	30.0	22.5	46	278
XVSA-42L	706.1205.420.20	250	52x2.0	30.0	23.5	55	366
XVSA-06S	706.1205.060.30	800	14x1.5	18.0	15.0	14	19
XVSA-08S	706.1205.080.30	800	16x1.5	20.0	15.0	17	29
XVSA-10S	706.1205.100.30	800	18x1.5	20.0	17.0	19	35
XVSA-12S	706.1205.120.30	630	20x1.5	20.0	17.0	22	45
XVSA-14S	706.1205.140.30	630	22x1.5	24.0	18.5	24	66
XVSA-16S	706.1205.160.30	630	24x1.5	24.0	19.5	27	79
XVSA-20S	706.1205.200.30	420	30x2.0	28.0	23.0	32	132
XVSA-25S	706.1205.250.30	420	36x2.0	30.0	25.5	41	213
XVSA-30S	706.1205.300.30	420	42x2.0	34.0	28.0	46	312
XVSA-38S	706.1205.380.30	420	52x2.0	36.0	33.0	55	456

Verschlussverschraubungen
Locking fittings
Racores de cierre

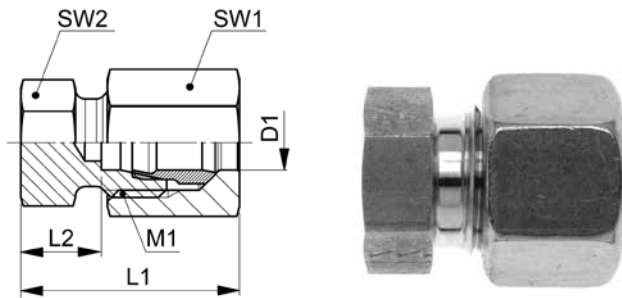
10



VSA-..L/S

Type -D1	Mat.-Nr.	PN	M1	L1	L2	SW1	SW2	g/Stk
VSA-06L	708.1205.060.20	500	12x1.5	24.0	15.0	14	12	22
VSA-08L	708.1205.080.20	500	14x1.5	26.0	15.0	17	14	30
VSA-10L	708.1205.100.20	500	16x1.5	27.5	15.5	19	17	38
VSA-12L	708.1205.120.20	500	18x1.5	27.5	15.5	22	19	50
VSA-15L	708.1205.150.20	500	22x1.5	31.0	16.0	27	24	84
VSA-18L	708.1205.180.20	500	26x1.5	31.5	17.0	32	27	124
VSA-22L	708.1205.220.20	250	30x2.0	35.5	17.0	36	32	166
VSA-28L	708.1205.280.20	250	36x2.0	35.5	17.0	41	41	238
VSA-35L	708.1205.350.20	250	45x2.0	42.0	22.5	50	46	356
VSA-42L	708.1205.420.20	250	52x2.0	42.5	23.5	60	55	556
VSA-06S	708.1205.060.30	800	14x1.5	26.0	15.0	17	14	36
VSA-08S	708.1205.080.30	800	16x1.5	28.0	15.0	19	17	42
VSA-10S	708.1205.100.30	800	18x1.5	29.5	17.0	22	19	64
VSA-12S	708.1205.120.30	630	20x1.5	29.5	17.0	24	22	78
VSA-14S	708.1205.140.30	630	22x1.5	34.5	18.5	27	24	118
VSA-16S	708.1205.160.30	630	24x1.5	35.0	19.5	30	27	142
VSA-20S	708.1205.200.30	420	30x2.0	40.5	23.0	36	32	236
VSA-25S	708.1205.250.30	420	36x2.0	43.5	25.5	46	41	448
VSA-30S	708.1205.300.30	420	42x2.0	48.5	28.0	50	46	540
VSA-38S	708.1205.380.30	420	52x2.0	53.0	33.0	60	55	870

Baumaße sind Ungefährmaße bei angezogener Überwurfmutter.

Sizes are approximate dimensions at tightened nut.

Las medidas son aproximadas con la tuerca de unión apretada.

D1=Rohr außen-Ø
M1=metrisches Anschlußgewinde

D1=tube outside diameter
M1=metric connecting thread

D1=Ø exterior del tubo
M1=rosca métrica conexión

Gerade Schottstutzen

mit Kontermutter

Bulkhead connectors

with counter nut

Cuerpos pasatabiques rectos

con contratuerca

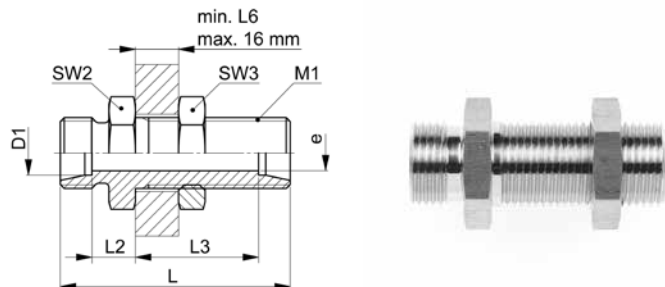

XGSV-..L/S KM

Type-D1	Mat.-Nr.	PN	M1	L	L2	L3	SW2	SW3	e	g/Stk
XGSV-06L KM	707.1501.060.20	500	12x1.5	48.0	7.0	27.0	17	17	4.0	46
XGSV-08L KM	707.1501.080.20	500	14x1.5	49.0	8.0	27.0	19	19	6.0	59
XGSV-10L KM	707.1501.100.20	500	16x1.5	52.0	10.0	28.0	22	22	8.0	78
XGSV-12L KM	707.1501.120.20	400	18x1.5	53.0	10.0	29.0	24	24	10.0	91
XGSV-15L KM	707.1501.150.20	400	22x1.5	57.0	12.0	31.0	27	30	12.0	147
XGSV-18L KM	707.1501.180.20	400	26x1.5	61.0	13.5	32.5	32	36	15.0	203
XGSV-22L KM	707.1501.220.20	250	30x2.0	66.0	16.5	34.5	36	41	19.0	286
XGSV-28L KM	707.1501.280.20	250	36x2.0	69.0	18.5	35.5	41	46	24.0	384
XGSV-35L KM	707.1501.350.20	250	45x2.0	76.0	18.5	36.5	50	55	30.0	609
XGSV-42L KM	707.1501.420.20	250	52x2.0	77.0	19.0	36.0	60	65	36.0	827
XGSV-06S KM	707.1501.060.30	800	14x1.5	55.0	12.0	29.0	19	19	4.0	75
XGSV-08S KM	707.1501.080.30	800	16x1.5	56.0	13.0	29.0	22	22	5.0	100
XGSV-10S KM	707.1501.100.30	800	18x1.5	59.0	14.5	29.5	24	24	7.0	125
XGSV-12S KM	707.1501.120.30	630	20x1.5	60.0	14.5	30.5	27	27	8.0	159
XGSV-14S KM	707.1501.140.30	630	22x1.5	65.0	17.0	32.0	30	30	10.0	200
XGSV-16S KM	707.1501.160.30	630	24x1.5	65.0	16.5	31.5	32	32	12.0	222
XGSV-20S KM	707.1501.200.30	420	30x2.0	72.0	17.5	33.5	41	41	16.0	382
XGSV-25S KM	707.1501.250.30	420	36x2.0	79.0	20.0	35.0	46	46	20.0	548
XGSV-30S KM	707.1501.300.30	420	42x2.0	86.0	21.5	37.5	50	50	25.0	703
XGSV-38S KM	707.1501.380.30	420	52x2.0	91.0	22.0	37.0	65	65	32.0	1169

für D1 ≤ 18 mm L6 = 3 mm
für D1 > 18 mm L6 = 4 mm

for D1 ≤ 18 mm L6 = 3 mm
for D1 > 18 mm L6 = 4 mm

para D1 ≤ 18 mm L6 = 3 mm
para D1 > 18 mm L6 = 4 mm

ISO 8434-1-BHS+LN

D1=Rohr außen-Ø
M1=metrisches Anschlußgewinde
e=kleinster Innen-Ø

D1=tube outside diameter
M1=metric connecting thread
e=minimum inside diameter

D1=Ø exterior del tubo
M1=rosca métrica conexión
e=Ø interior mínimo

Gerade Schottverschraubungen
Bulkhead fittings
Racores pasatabiques rectos

10

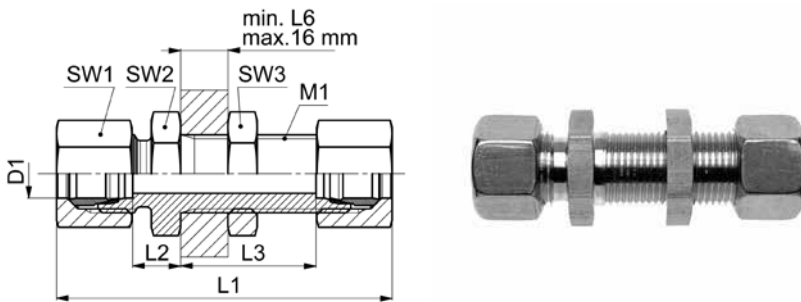

GSV-..L/S

Type -D1	Mat.-Nr.	PN	M1	L1	L2	L3	SW1	SW2	SW3	g/Stk
GSV-06L	708.1500.060.20	500	12x1.5	64.0	7.0	27.0	14	17	17	72
GSV-08L	708.1500.080.20	500	14x1.5	65.0	8.0	27.0	17	19	19	83
GSV-10L	708.1500.100.20	500	16x1.5	68.0	10.0	28.0	19	22	22	125
GSV-12L	708.1500.120.20	400	18x1.5	69.0	10.0	29.0	22	24	24	135
GSV-15L	708.1500.150.20	400	22x1.5	73.0	12.0	31.0	27	27	30	230
GSV-18L	708.1500.180.20	400	26x1.5	79.0	13.5	32.5	32	32	36	345
GSV-22L	708.1500.220.20	250	30x2.0	84.0	16.5	34.5	36	36	41	435
GSV-28L	708.1500.280.20	250	36x2.0	90.0	18.5	35.5	41	41	46	545
GSV-35L	708.1500.350.20	250	45x2.0	100.0	18.5	36.5	50	50	55	874
GSV-42L	708.1500.420.20	250	52x2.0	101.0	19.0	36.0	60	60	65	1365
GSV-06S	708.1500.060.30	800	14x1.5	71.0	12.0	29.0	17	19	19	112
GSV-08S	708.1500.080.30	800	16x1.5	72.0	13.0	29.0	19	22	22	132
GSV-10S	708.1500.100.30	800	18x1.5	77.0	14.5	29.5	22	24	24	170
GSV-12S	708.1500.120.30	630	20x1.5	78.0	14.5	30.5	24	27	27	215
GSV-14S	708.1500.140.30	630	22x1.5	85.0	17.0	32.0	27	30	30	322
GSV-16S	708.1500.160.30	630	24x1.5	85.0	16.5	31.5	30	32	32	345
GSV-20S	708.1500.200.30	420	30x2.0	97.0	17.5	33.5	36	41	41	575
GSV-25S	708.1500.250.30	420	36x2.0	106.0	20.0	35.0	46	46	46	949
GSV-30S	708.1500.300.30	420	42x2.0	115.0	21.5	37.5	50	50	50	1120
GSV-38S	708.1500.380.30	420	52x2.0	123.0	22.0	37.0	60	65	65	1445

Baumaße sind Ungefährmaße bei angezogener Überwurfmutter.

Sizes are approximate dimensions at tightened nut.

Las medidas son aproximadas con la tuerca de unión apretada.

für D1 ≤ 18 mm L6 = 3 mm
 für D1 > 18 mm L6 = 4 mm

for D1 ≤ 18 mm L6 = 3 mm
 for D1 > 18 mm L6 = 4 mm

para D1 ≤ 18 mm L6 = 3 mm
 para D1 > 18 mm L6 = 4 mm

ISO 8434-1-BHSC+LN

D1=Rohraußen-Ø
 M1=metrisches Anschlußgewinde

D1=tube outside diameter
 M1=metric connecting thread

D1=Ø exterior del tubo
 M1=rosca métrica conexión

Winkel-Schottstutzen

mit Kontermutter

Bulkhead elbow connectors

with counter nut

Cuerpos pasatabiques a codo

con contratuerca

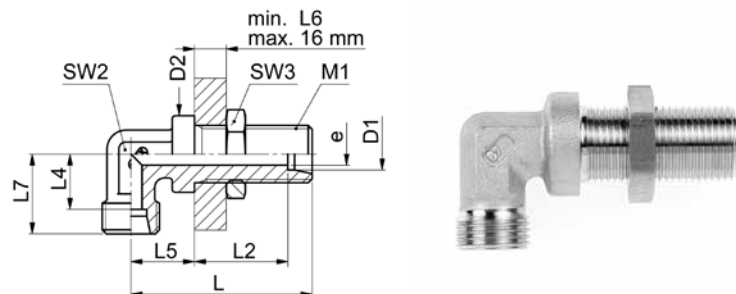

XWSV-..L/S KM

Type-D1	Mat.-Nr.	PN	D2	M1	L	L2	L4	L5	L7	SW2	SW3	e	g/Stk
XWSV-06L KM	707.2700.060.20	500	17.0	12x1.5	48.0	27.0	12.0	14.0	19.0	12	17	4.0	50
XWSV-08L KM	707.2700.080.20	500	19.0	14x1.5	51.0	27.0	14.0	17.0	21.0	12	19	6.0	53
XWSV-10L KM	707.2700.100.20	500	22.0	16x1.5	53.0	28.0	15.0	18.0	22.0	14	22	8.0	80
XWSV-12L KM	707.2700.120.20	400	24.0	18x1.5	56.0	29.0	17.0	20.0	24.0	17	24	10.0	104
XWSV-15L KM	707.2700.150.20	400	28.0	22x1.5	61.0	31.0	21.0	23.0	28.0	19	30	12.0	161
XWSV-18L KM	707.2700.180.20	400	32.0	26x1.5	64.0	32.5	23.5	24.0	31.0	24	36	15.0	232
XWSV-22L KM	707.2700.220.20	250	36.0	30x2.0	72.0	34.5	27.5	30.0	35.0	27	41	19.0	304
XWSV-28L KM	707.2700.280.20	250	42.0	36x2.0	77.0	35.5	30.5	34.0	38.0	36	46	24.0	469
XWSV-35L KM	707.2700.350.20	250	50.0	45x2.0	86.0	36.5	34.5	39.0	45.0	41	55	30.0	709
XWSV-42L KM	707.2700.420.20	250	60.0	52x2.0	90.0	36.0	40.0	43.0	51.0	50	65	36.0	1140
XWSV-06S KM	707.2700.060.30	800	19.0	14x1.5	53.0	29.0	16.0	17.0	23.0	12	19	4.0	78
XWSV-08S KM	707.2700.080.30	800	22.0	16x1.5	54.0	29.0	17.0	18.0	24.0	14	22	5.0	103
XWSV-10S KM	707.2700.100.30	800	24.0	18x1.5	57.0	29.5	17.5	20.0	25.0	17	24	7.0	132
XWSV-12S KM	707.2700.120.30	630	27.0	20x1.5	59.0	30.5	21.5	21.0	29.0	17	27	8.0	168
XWSV-14S KM	707.2700.140.30	630	28.0	22x1.5	63.0	32.0	22.0	23.0	30.0	19	30	10.0	192
XWSV-16S KM	707.2700.160.30	630	32.0	24x1.5	64.0	31.5	24.5	24.0	33.0	24	32	12.0	252
XWSV-20S KM	707.2700.200.30	420	36.0	30x2.0	74.0	33.5	26.5	30.0	37.0	27	41	16.0	380
XWSV-25S KM	707.2700.250.30	420	42.0	36x2.0	81.0	35.0	30.0	34.0	42.0	36	46	20.0	623
XWSV-30S KM	707.2700.300.30	420	50.0	42x2.0	90.0	37.5	35.5	39.0	49.0	41	50	25.0	891
XWSV-38S KM	707.2700.380.30	420	60.0	52x2.0	96.0	37.0	41.0	43.0	57.0	50	65	32.0	1483

für D1 ≤ 18 mm L6 = 3 mm
für D1 > 18 mm L6 = 4 mm

for D1 ≤ 18 mm L6 = 3 mm
for D1 > 18 mm L6 = 4 mm

para D1 ≤ 18 mm L6 = 3 mm
para D1 > 18 mm L6 = 4 mm

ISO 8434-1-BHE+LN

D1=Rohr außen-Ø
M1=metrisches Anschlußgewinde
e=kleinster Innen-Ø

D1=tube outside diameter
M1=metric connecting thread
e=minimum inside diameter

D1=Ø exterior del tubo
M1=rosca métrica conexión
e=Ø interior mínimo

Winkel-Schottverschraubungen
Bulkhead elbow fittings
Racores pasatabiques a codo

10

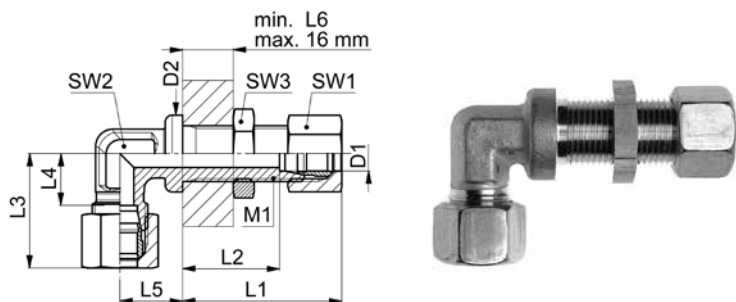

WSV-..L/S

Type -D1	Mat.-Nr.	PN	D2	M1	L1	L2	L3	L4	L5	SW1	SW2	SW3	g/Stk
WSV-06L	708.2700.060.20	500	17.0	12x1.5	42.0	27.0	27.0	12.0	14.0	14	12	17	73
WSV-08L	708.2700.080.20	500	19.0	14x1.5	42.0	27.0	29.0	14.0	17.0	17	12	19	92
WSV-10L	708.2700.100.20	500	22.0	16x1.5	43.5	28.0	30.5	15.0	18.0	19	14	22	172
WSV-12L	708.2700.120.20	400	24.0	18x1.5	44.5	29.0	32.5	17.0	20.0	22	17	24	215
WSV-15L	708.2700.150.20	400	28.0	22x1.5	47.0	31.0	37.0	21.0	23.0	27	19	30	262
WSV-18L	708.2700.180.20	400	32.0	26x1.5	49.5	32.5	40.5	23.5	24.0	32	24	36	380
WSV-22L	708.2700.220.20	250	36.0	30x2.0	51.5	34.5	44.5	27.5	30.0	36	27	41	490
WSV-28L	708.2700.280.20	250	42.0	36x2.0	52.5	35.5	47.5	30.5	34.0	41	36	46	678
WSV-35L	708.2700.350.20	250	50.0	45x2.0	59.0	36.5	57.0	34.5	39.0	50	41	55	1055
WSV-42L	708.2700.420.20	250	60.0	52x2.0	59.5	36.0	63.5	40.0	43.0	60	50	65	1583
WSV-06S	708.2700.060.30	800	19.0	14x1.5	44.0	29.0	31.0	16.0	17.0	17	12	19	117
WSV-08S	708.2700.080.30	800	22.0	16x1.5	44.0	29.0	32.5	17.0	18.0	19	14	22	185
WSV-10S	708.2700.100.30	800	24.0	18x1.5	46.5	29.5	34.5	17.5	20.0	22	17	24	195
WSV-12S	708.2700.120.30	630	27.0	20x1.5	47.5	30.0	38.5	21.5	21.0	24	17	27	245
WSV-14S	708.2700.140.30	630	28.0	22x1.5	50.5	32.0	40.5	22.0	23.0	27	19	30	375
WSV-16S	708.2700.160.30	630	32.0	24x1.5	51.0	31.5	44.0	24.5	24.0	30	24	32	395
WSV-20S	708.2700.200.30	420	36.0	30x2.0	56.5	33.5	49.5	26.5	30.0	36	27	41	606
WSV-25S	708.2700.250.30	420	42.0	36x2.0	60.5	35.0	55.5	30.0	34.0	46	36	46	1050
WSV-30S	708.2700.300.30	420	50.0	42x2.0	65.5	37.5	63.5	35.5	39.0	50	41	50	1360
WSV-38S	708.2700.380.30	420	60.0	52x2.0	70.0	37.0	74.0	41.0	43.0	60	50	65	2060

Baumaße sind Ungefährmaße bei angezogener Überwurfmutter.

Sizes are approximate dimensions at tightened nut.

Las medidas son aproximadas con la tuerca de unión apretada.

für D1 ≤ 18 mm L6 = 3 mm
 für D1 > 18 mm L6 = 4 mm

for D1 ≤ 18 mm L6 = 3 mm
 for D1 > 18 mm L6 = 4 mm

para D1 ≤ 18 mm L6 = 3 mm
 para D1 > 18 mm L6 = 4 mm

ISO 8434-1-BHEC+LN

D1=Rohraußen-Ø
 M1=metrisches Anschlußgewinde

D1=tube outside diameter
 M1=metric connecting thread

D1=Ø exterior del tubo
 M1=rosca métrica conexión

Gerade Einschraubstutzen

Abdichtung durch Dichtkante Form B nach DIN 3852-2

Straight male adaptor connectors

sealing edge form B acc. DIN 3852-2

Cuerpos para roscar rectos

cierre hermético mediante borde de obturación forma B según DIN 3852-2

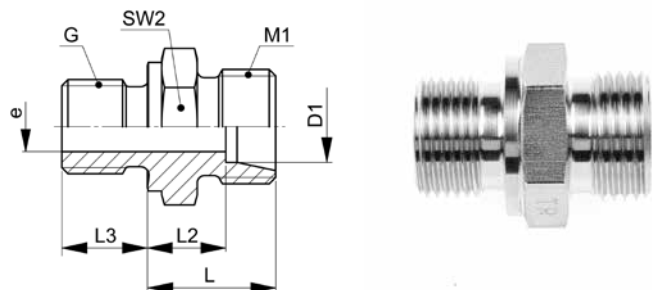

XGEV-..LR

Type-D1 G	Mat.-Nr.	PN	G	M1	L	L2	L3	SW2	e	g/Stk
G=Rohrgewinde (zylindrisch)		G=BSP thread (parallel)				G=rosca de conexión (cilíndrica)				
◇ XGEV-04LLR 1.8	706.1141.060.10	100	1/8	8x1.0	13.5	9.5	8.0	14	3.0	10
◇ XGEV-06LLR 1.8	706.1141.100.10	100	1/8	10x1.0	13.5	8.0	8.0	14	4.5	10
◇ XGEV-08LLR 1.8	706.1141.160.10	100	1/8	12x1.0	14.5	9.0	8.0	14	4.5	12
◇ XGEV-06LR 1.8	706.1141.100.20	500	1/8	12x1.5	15.5	8.5	8.0	14	4.0	14
XGEV-06LR 1.4	706.1141.110.20	500	1/4	12x1.5	17.0	10.0	12.0	19	4.0	29
XGEV-06LR 3.8	706.1141.120.20	500	3/8	12x1.5	18.5	11.5	12.0	22	4.0	47
XGEV-06LR 1.2	706.1141.125.20	500	1/2	12x1.5	20.0	13.0	14.0	27	4.0	81
XGEV-08LR 1.8	706.1141.160.20	500	1/8	14x1.5	15.5	8.5	8.0	14	4.0	16
◇ XGEV-08LR 1.4	706.1141.170.20	500	1/4	14x1.5	17.0	10.0	12.0	19	6.0	28
XGEV-08LR 3.8	706.1141.180.20	500	3/8	14x1.5	19.5	12.5	12.0	22	6.0	49
XGEV-08LR 1.2	706.1141.185.20	500	1/2	14x1.5	20.0	13.0	14.0	27	6.0	79
XGEV-10LR 1.8	706.1141.265.20	500	1/8	16x1.5	17.5	10.5	8.0	17	4.0	22
◇ XGEV-10LR 1.4	706.1141.270.20	500	1/4	16x1.5	18.0	11.0	12.0	19	7.0	29
XGEV-10LR 3.8	706.1141.280.20	500	3/8	16x1.5	19.5	12.5	12.0	22	8.0	44
XGEV-10LR 1.2	706.1141.285.20	500	1/2	16x1.5	21.0	14.0	14.0	27	8.0	77
XGEV-10LR 3.4	706.1141.290.20	500	3/4	16x1.5	21.0	14.0	16.0	32	8.0	102
XGEV-10LR 1.1	706.1141.295.20	500	1	16x1.5	24.0	17.0	18.0	41	8.0	178
XGEV-12LR 1.8	706.1141.375.20	400	1/8	18x1.5	18.5	11.5	8.0	19	4.0	30
XGEV-12LR 1.4	706.1141.380.20	400	1/4	18x1.5	19.0	12.0	12.0	19	7.0	33
◇ XGEV-12LR 3.8	706.1141.390.20	400	3/8	18x1.5	19.5	12.5	12.0	22	9.0	43
XGEV-12LR 1.2	706.1141.400.20	400	1/2	18x1.5	20.0	13.0	14.0	27	9.0	71
XGEV-12LR 3.4	706.1141.405.20	400	3/4	18x1.5	21.0	14.0	16.0	32	9.0	125
XGEV-12LR 1.1	706.1141.408.20	400	1	18x1.5	24.0	17.0	18.0	41	10.0	178
XGEV-15LR 1.4	706.1141.528.20	400	1/4	22x1.5	20.0	13.0	12.0	24	7.0	51
XGEV-15LR 3.8	706.1141.532.20	400	3/8	22x1.5	20.5	13.5	12.0	24	9.0	56
◇ XGEV-15LR 1.2	706.1141.534.20	400	1/2	22x1.5	21.0	14.0	14.0	27	11.0	73
XGEV-15LR 3.4	706.1141.536.20	400	3/4	22x1.5	22.0	15.0	16.0	32	11.0	125
XGEV-15LR 1.1	706.1141.541.20	400	1	22x1.5	25.0	18.0	18.0	41	12.0	184
XGEV-18LR 3.8	706.1141.644.20	400	3/8	26x1.5	22.0	14.5	12.0	27	9.0	77
◇ XGEV-18LR 1.2	706.1141.646.20	400	1/2	26x1.5	22.0	14.5	14.0	27	14.0	72
XGEV-18LR 3.4	706.1141.648.20	400	3/4	26x1.5	22.0	14.5	16.0	32	14.0	119
XGEV-18LR 1.1	706.1141.652.20	400	1	26x1.5	25.0	17.5	18.0	41	15.0	188

Fortsetzung auf nächster linker Seite

To be continued on next left page

Continuación próxima página izquierda

D1=Rohr außen-Ø
M1=metrisches Anschlußgewinde
e=kleinster Innen-Ø
◇=entspricht Reihe nach DIN 2353

D1=tube outside diameter
M1=metric connecting thread
e=minimum inside diameter
◇=according to series DIN 2353

D1=Ø exterior del tubo
M1=rosca métrica conexión
e=Ø interior mínimo
◇=según serie DIN 2353

Gerade Einschraubverschraubungen

Abdichtung durch Dichtkante Form B nach DIN 3852-2

Straight male adaptor fittings

sealing edge form B acc. DIN 3852-2

Racores para roscar rectos

cierre hermético mediante borde de obturación forma B según DIN 3852-2

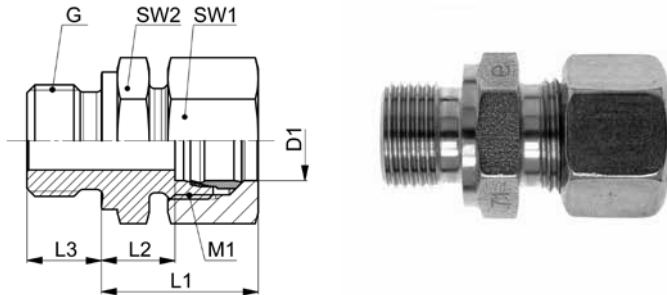

GEV-..LR

Type-D1 G	Mat.-Nr.	PN	G	M1	L1	L2	L3	SW1	SW2	g/Stk
G=Rohrgewinde (zylindrisch)	G=BSP thread (parallel)									
			G=rosca de conexión (cilíndrica)							
◇ GEV-04LLR 1.8	708.1141.060.10	100	1/8	8x1.0	19.5	9.5	8.0	10	14	15
◇ GEV-06LLR 1.8	708.1141.100.10	100	1/8	10x1.0	19.5	8.0	8.0	12	14	19
◇ GEV-08LLR 1.8	708.1141.160.10	100	1/8	12x1.0	20.5	9.0	8.0	14	14	20
◇ GEV-06LR 1.8	708.1141.100.20	500	1/8	12x1.5	23.5	8.5	8.0	14	14	25
GEV-06LR 1.4	708.1141.110.20	500	1/4	12x1.5	25.0	10.0	12.0	14	19	40
GEV-06LR 3.8	708.1141.120.20	500	3/8	12x1.5	26.5	11.5	12.0	14	22	58
GEV-06LR 1.2	708.1141.125.20	500	1/2	12x1.5	28.0	13.0	14.0	14	27	100
GEV-08LR 1.8	708.1141.160.20	500	1/8	14x1.5	23.5	8.5	8.0	17	14	32
◇ GEV-08LR 1.4	708.1141.170.20	500	1/4	14x1.5	25.0	10.0	12.0	17	19	43
GEV-08LR 3.8	708.1141.180.20	500	3/8	14x1.5	27.5	12.5	12.0	17	22	59
GEV-08LR 1.2	708.1141.185.20	500	1/2	14x1.5	28.0	13.0	14.0	17	27	99
GEV-10LR 1.8	708.1141.265.20	500	1/8	16x1.5	25.5	10.5	8.0	19	17	43
◇ GEV-10LR 1.4	708.1141.270.20	500	1/4	16x1.5	26.0	11.0	12.0	19	19	50
GEV-10LR 3.8	708.1141.280.20	500	3/8	16x1.5	27.5	12.5	12.0	19	22	64
GEV-10LR 1.2	708.1141.285.20	500	1/2	16x1.5	29.0	14.0	14.0	19	27	102
GEV-10LR 3.4	708.1141.290.20	500	3/4	16x1.5	29.0	14.0	16.0	19	32	124
GEV-10LR 1.1	708.1141.295.20	500	1	16x1.5	32.5	17.0	18.0	19	41	194
GEV-12LR 1.8	708.1141.375.20	400	1/8	18x1.5	26.5	11.5	8.0	22	19	58
GEV-12LR 1.4	708.1141.380.20	400	1/4	18x1.5	27.0	12.0	12.0	22	19	62
◇ GEV-12LR 3.8	708.1141.390.20	400	3/8	18x1.5	27.5	12.5	12.0	22	22	70
GEV-12LR 1.2	708.1141.400.20	400	1/2	18x1.5	28.0	13.0	14.0	22	27	101
GEV-12LR 3.4	708.1141.405.20	400	3/4	18x1.5	29.0	14.0	16.0	22	32	104
GEV-12LR 1.1	708.1141.408.20	400	1	18x1.5	32.5	17.0	18.0	22	41	206
GEV-15LR 1.4	708.1141.528.20	400	1/4	22x1.5	28.0	13.0	12.0	27	24	98
GEV-15LR 3.8	708.1141.532.20	400	3/8	22x1.5	28.5	13.5	12.0	27	24	102
◇ GEV-15LR 1.2	708.1141.534.20	400	1/2	22x1.5	29.0	14.0	14.0	27	27	114
GEV-15LR 3.4	708.1141.536.20	400	3/4	22x1.5	30.0	15.0	16.0	27	32	172
GEV-15LR 1.1	708.1141.541.20	400	1	22x1.5	34.0	18.0	18.0	27	41	229
GEV-18LR 3.8	708.1141.644.20	400	3/8	26x1.5	31.0	14.5	12.0	32	27	136
◇ GEV-18LR 1.2	708.1141.646.20	400	1/2	26x1.5	31.0	14.5	14.0	32	27	142
GEV-18LR 3.4	708.1141.648.20	400	3/4	26x1.5	31.0	14.5	16.0	32	32	185
GEV-18LR 1.1	708.1141.652.20	400	1	26x1.5	34.5	17.5	18.0	32	41	256

Fortsetzung auf nächster rechter Seite

To be continued on next right page

Continuación próxima página derecha

D1=Rohr außen-Ø
 M1=metrisches Anschlußgewinde
 ◇=entspricht Reihe nach DIN 2353

D1=tube outside diameter
 M1=metric connecting thread
 ◇=according to series DIN 2353

D1=Ø exterior del tubo
 M1=rosca métrica conexión
 ◇=según serie DIN 2353

Gerade Einschraubstutzen

Abdichtung durch Dichtkante Form B nach DIN 3852-2

Straight male adaptor connectors

sealing edge form B acc. DIN 3852-2

Cuerpos para roscar rectos

cierre hermético mediante borde de obturación forma B según DIN 3852-2

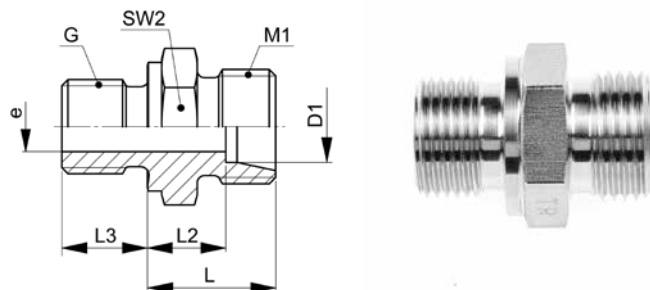

XGEV-..LR

Type-D1 G	Mat.-Nr.	PN	G	M1	L	L2	L3	SW2	e	g/Stk
G=Rohrgewinde (zylindrisch)		G=BSP thread (parallel)			G=rosca de conexión (cilíndrica)					
XGEV-22LR 3.8	706.1141.763.20	250	3/8	30x2.0	23.5	16.0	12.0	32	9.0	104
XGEV-22LR 1.2	706.1141.764.20	250	1/2	30x2.0	24.0	16.5	14.0	32	14.0	99
◇ XGEV-22LR 3.4	706.1141.768.20	250	3/4	30x2.0	24.0	16.5	16.0	32	18.0	106
XGEV-22LR 1.1	706.1141.770.20	250	1	30x2.0	25.0	17.5	18.0	41	18.0	199
XGEV-22LR 5.4	706.1141.771.20	250	1 1/4	30x2.0	26.0	18.5	20.0	50	18.0	292
XGEV-28LR 1.2	706.1141.840.20	250	1/2	36x2.0	25.0	17.5	14.0	41	14.0	158
XGEV-28LR 3.4	706.1141.845.20	250	3/4	36x2.0	25.0	17.5	16.0	41	18.0	165
◇ XGEV-28LR 1.1	706.1141.850.20	250	1	36x2.0	25.0	17.5	18.0	41	23.0	173
XGEV-28LR 5.4	706.1141.860.20	250	1 1/4	36x2.0	26.0	18.5	20.0	50	23.0	328
XGEV-28LR 3.2	706.1141.865.20	250	1 1/2	36x2.0	28.0	20.5	22.0	55	23.0	443
XGEV-35LR 1.2	706.1141.920.20	250	1/2	45x2.0	28.0	17.5	14.0	46	14.0	198
XGEV-35LR 3.4	706.1141.915.20	250	3/4	45x2.0	28.0	17.5	16.0	46	18.0	236
XGEV-35LR 1.1	706.1141.925.20	250	1	45x2.0	28.0	17.5	18.0	46	23.0	247
◇ XGEV-35LR 5.4	706.1141.944.20	250	1 1/4	45x2.0	28.0	17.5	20.0	50	30.0	281
XGEV-35LR 3.2	706.1141.950.20	250	1 1/2	45x2.0	30.0	19.5	22.0	55	30.0	433
XGEV-42LR 1.1	706.1141.980.20	250	1	52x2.0	30.0	19.0	18.0	55	23.0	364
XGEV-42LR 5.4	706.1141.985.20	250	1 1/4	52x2.0	30.0	19.0	20.0	55	30.0	368
◇ XGEV-42LR 3.2	706.1141.992.20	250	1 1/2	52x2.0	30.0	19.0	22.0	55	36.0	361

ISO 8434-1-SDS-B

D1=Rohr außen-Ø
M1=metrisches Anschlußgewinde
e=kleinster Innen-Ø
◇=entspricht Reihe nach DIN 2353

D1=tube outside diameter
M1=metric connecting thread
e=minimum inside diameter
◇=according to series DIN 2353

D1=Ø exterior del tubo
M1=rosca métrica conexión
e=Ø interior mínimo
◇=según serie DIN 2353

Gerade Einschraubverschraubungen

Abdichtung durch Dichtkante Form B nach DIN 3852-2

Straight male adaptor fittings

sealing edge form B acc. DIN 3852-2

Racores para roscar rectos

cierre hermético mediante borde de obturación forma B según DIN 3852-2

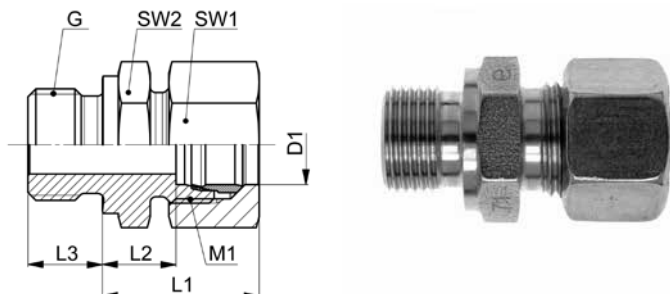

GEV-..LR

Type-D1 G	Mat.-Nr.	PN	G	M1	L1	L2	L3	SW1	SW2	g/Stk
G=Rohrgewinde (zylindrisch)		G=BSP thread (parallel)				G=rosca de conexión (cilíndrica)				
GEV-22LR 3.8	708.1141.763.20	250	3/8	30x2.0	32.5	16.0	12.0	36	32	180
GEV-22LR 1.2	708.1141.764.20	250	1/2	30x2.0	33.0	16.5	14.0	36	32	200
◇ GEV-22LR 3.4	708.1141.768.20	250	3/4	30x2.0	33.0	16.5	16.0	36	32	196
GEV-22LR 1.1	708.1141.770.20	250	1	30x2.0	34.0	17.5	18.0	36	41	289
GEV-22LR 5.4	708.1141.771.20	250	1 1/4	30x2.0	35.0	18.5	20.0	36	50	368
GEV-28LR 1.2	708.1141.840.20	250	1/2	36x2.0	34.0	17.5	14.0	41	41	210
GEV-28LR 3.4	708.1141.845.20	250	3/4	36x2.0	34.0	17.5	16.0	41	41	230
◇ GEV-28LR 1.1	708.1141.850.20	250	1	36x2.0	34.0	17.5	18.0	41	41	270
GEV-28LR 5.4	708.1141.860.20	250	1 1/4	36x2.0	35.0	18.5	20.0	41	50	427
GEV-28LR 3.2	708.1141.865.20	250	1 1/2	36x2.0	40.5	20.5	22.0	41	55	555
GEV-35LR 1.2	708.1141.920.20	250	1/2	45x2.0	39.0	17.5	14.0	50	46	380
GEV-35LR 3.4	708.1141.915.20	250	3/4	45x2.0	39.0	17.5	16.0	50	46	400
GEV-35LR 1.1	708.1141.925.20	250	1	45x2.0	39.0	17.5	18.0	50	46	412
◇ GEV-35LR 5.4	708.1141.944.20	250	1 1/4	45x2.0	39.0	17.5	20.0	50	55	465
GEV-35LR 3.2	708.1141.950.20	250	1 1/2	45x2.0	41.0	19.5	22.0	50	50	598
GEV-42LR 1.1	708.1141.980.20	250	1	52x2.0	42.0	19.0	18.0	60	55	562
GEV-42LR 5.4	708.1141.985.20	250	1 1/4	52x2.0	42.0	19.0	20.0	60	55	620
◇ GEV-42LR 3.2	708.1141.992.20	250	1 1/2	52x2.0	42.0	19.0	22.0	60	55	610

Baumaße sind Ungefährmaße bei angezogener Überwurfmutter.

Sizes are approximate dimensions at tightened nut.

Las medidas son aproximadas con la tuerca de unión apretada.

ISO 8434-1-SDSC-B

D1=Rohr außen-Ø
M1=metrisches Anschlußgewinde
◇=entspricht Reihe nach DIN 2353

D1=tube outside diameter
M1=metric connecting thread
◇=according to series DIN 2353

D1=Ø exterior del tubo
M1=rosca métrica conexión
◇=según serie DIN 2353

Gerade Einschraubstutzen

Abdichtung durch Profildichtring Form E nach ISO 1179-2

Straight male adaptor connectors

profile sealing ring form E acc. ISO 1179-2

Cuerpos para roscar rectos

cierre hermético mediante junta con perfil forma E según ISO 1179-2

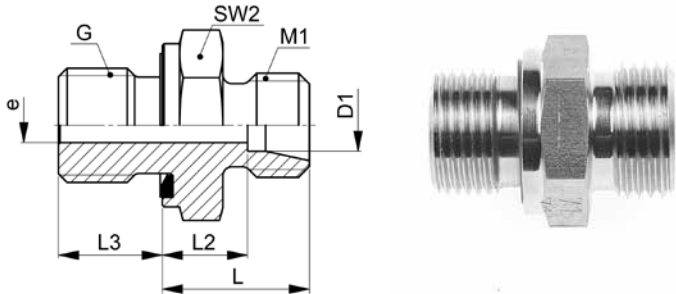

XGEV-..LR WD

Type-D1 G	Mat.-Nr.	PN	G	M1	L	L2	L3	SW2	e	g/Stk
G=Rohrgewinde (zylindrisch)		G=BSP thread (parallel)				G=rosca de conexión (cilíndrica)				
◇ XGEV-04LLR 1.8 WD	707.1171.060.10	100	1/8	8x1.0	13.0	9.5	8.0	14	3.0	12
◇ XGEV-06LLR 1.8 WD	707.1171.100.10	100	1/8	10x1.0	13.5	8.0	8.0	14	4.5	10
◇ XGEV-08LLR 1.8 WD	707.1171.160.10	100	1/8	12x1.0	14.5	9.0	8.0	14	4.5	12
◇ XGEV-06LR 1.8 WD	707.1171.100.20	500	1/8	12x1.5	15.5	8.5	8.0	14	4.0	14
XGEV-06LR 1.4 WD	707.1171.110.20	500	1/4	12x1.5	17.0	10.0	12.0	19	4.0	28
XGEV-06LR 3.8 WD	707.1171.120.20	500	3/8	12x1.5	18.5	11.5	12.0	22	4.0	46
XGEV-06LR 1.2 WD	707.1171.125.20	500	1/2	12x1.5	20.0	13.0	14.0	27	4.0	80
XGEV-08LR 1.8 WD	707.1171.160.20	500	1/8	14x1.5	16.5	8.5	8.0	14	4.0	17
◇ XGEV-08LR 1.4 WD	707.1171.170.20	500	1/4	14x1.5	17.0	10.0	12.0	19	6.0	27
XGEV-08LR 3.8 WD	707.1171.180.20	500	3/8	14x1.5	18.5	12.5	12.0	22	6.0	46
XGEV-08LR 1.2 WD	707.1171.185.20	500	1/2	14x1.5	20.0	13.0	14.0	27	6.0	78
XGEV-10LR 1.8 WD	707.1171.265.20	500	1/8	16x1.5	17.5	10.5	8.0	17	4.0	22
◇ XGEV-10LR 1.4 WD	707.1171.270.20	500	1/4	16x1.5	18.0	11.0	12.0	19	7.0	28
XGEV-10LR 3.8 WD	707.1171.280.20	500	3/8	16x1.5	19.5	12.5	12.0	22	8.0	42
XGEV-10LR 1.2 WD	707.1171.285.20	500	1/2	16x1.5	21.0	14.0	14.0	27	8.0	74
XGEV-12LR 1.8 WD	707.1171.375.20	400	1/8	18x1.5	18.5	11.5	8.0	19	4.0	26
XGEV-12LR 1.4 WD	707.1171.380.20	400	1/4	18x1.5	19.0	12.0	12.0	19	7.0	30
◇ XGEV-12LR 3.8 WD	707.1171.390.20	400	3/8	18x1.5	19.5	12.5	12.0	22	9.0	43
XGEV-12LR 1.2 WD	707.1171.400.20	400	1/2	18x1.5	20.0	13.0	14.0	27	9.0	71
XGEV-12LR 3.4 WD	707.1171.405.20	400	3/4	18x1.5	21.0	14.0	16.0	32	9.0	124
XGEV-15LR 1.4 WD	707.1171.528.20	400	1/4	22x1.5	20.0	13.0	12.0	24	7.0	52
XGEV-15LR 3.8 WD	707.1171.532.20	400	3/8	22x1.5	20.5	13.5	12.0	24	9.0	55
◇ XGEV-15LR 1.2 WD	707.1171.534.20	400	1/2	22x1.5	21.0	14.0	14.0	27	11.0	73
XGEV-15LR 3.4 WD	707.1171.536.20	400	3/4	22x1.5	22.0	15.0	16.0	32	11.0	124
XGEV-18LR 3.8 WD	707.1171.644.20	400	3/8	26x1.5	22.0	14.5	12.0	27	9.0	76
◇ XGEV-18LR 1.2 WD	707.1171.646.20	400	1/2	26x1.5	22.0	14.5	14.0	27	14.0	72
XGEV-18LR 3.4 WD	707.1171.648.20	400	3/4	26x1.5	22.0	14.5	16.0	32	14.0	118
XGEV-22LR 1.2 WD	707.1171.764.20	250	1/2	30x2.0	23.5	16.5	14.0	32	14.0	98
◇ XGEV-22LR 3.4 WD	707.1171.768.20	250	3/4	30x2.0	24.0	16.5	16.0	32	18.0	104
XGEV-22LR 1.1 WD	707.1171.770.20	250	1	30x2.0	25.0	17.5	18.0	41	18.0	198
XGEV-22LR 5.4 WD	707.1171.771.20	250	1 1/4	30x2.0	26.0	18.5	20.0	50	18.0	292

Fortsetzung auf nächster linker Seite

To be continued on next left page

Continuación próxima página izquierda

D1=Rohr außen-Ø
M1=metrisches Anschlußgewinde
e=kleinster Innen-Ø
◇=entspricht Reihe nach DIN 2353

D1=tube outside diameter
M1=metric connecting thread
e=minimum inside diameter
◇=according to series DIN 2353

D1=Ø exterior del tubo
M1=rosca métrica conexión
e=Ø interior mínimo
◇=según serie DIN 2353

Gerade Einschraubverschraubungen

Abdichtung durch Profildichtring Form E nach ISO 1179-2

Straight male adaptor fittings

profile sealing ring form E acc. ISO 1179-2

Racores para roscar rectos

cierre hermético mediante junta con perfil forma E según ISO 1179-2

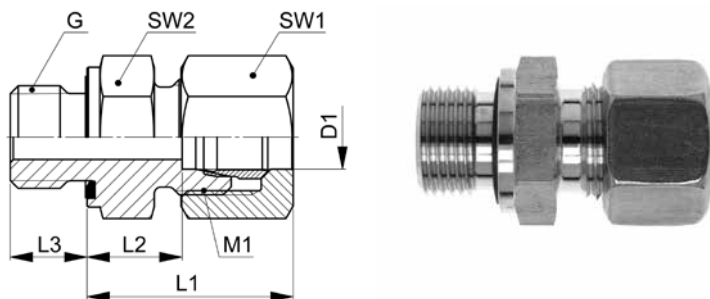

GEV-..LR WD

Type-D1 G	Mat.-Nr.	PN	G	M1	L1	L2	L3	SW1	SW2	g/Stk
G=Rohrgewinde (zylindrisch)		G=BSP thread (parallel)				G=rosca de conexión (cilíndrica)				
◇ GEV-04LLR 1.8 WD	708.1171.060.10	100	1/8	8x1.0	20.0	9.5	8.0	10	14	17
◇ GEV-06LLR 1.8 WD	708.1171.100.10	100	1/8	10x1.0	20.0	8.0	8.0	12	14	19
◇ GEV-08LLR 1.8 WD	708.1171.160.10	100	1/8	12x1.0	20.5	9.0	8.0	14	14	20
◇ GEV-06LR 1.8 WD	708.1171.100.20	500	1/8	12x1.5	23.5	8.5	8.0	14	14	25
GEV-06LR 1.4 WD	708.1171.110.20	500	1/4	12x1.5	25.0	10.0	12.0	14	19	40
GEV-06LR 3.8 WD	708.1171.120.20	500	3/8	12x1.5	26.5	11.5	12.0	14	22	58
GEV-06LR 1.2 WD	708.1171.125.20	500	1/2	12x1.5	28.0	13.0	14.0	14	27	100
GEV-08LR 1.8 WD	708.1171.160.20	500	1/8	14x1.5	24.5	8.5	8.0	17	14	37
◇ GEV-08LR 1.4 WD	708.1171.170.20	500	1/4	14x1.5	25.0	10.0	12.0	17	19	63
GEV-08LR 3.8 WD	708.1171.180.20	500	3/8	14x1.5	26.5	12.5	12.0	17	22	59
GEV-08LR 1.2 WD	708.1171.185.20	500	1/2	14x1.5	28.0	13.0	14.0	17	27	99
GEV-10LR 1.8 WD	708.1171.265.20	500	1/8	16x1.5	25.5	10.5	8.0	19	17	43
◇ GEV-10LR 1.4 WD	708.1171.270.20	500	1/4	16x1.5	26.0	11.0	12.0	19	19	50
GEV-10LR 3.8 WD	708.1171.280.20	500	3/8	16x1.5	27.5	12.5	12.0	19	22	64
GEV-10LR 1.2 WD	708.1171.285.20	500	1/2	16x1.5	29.0	14.0	14.0	19	27	102
GEV-12LR 1.8 WD	708.1171.375.20	400	1/8	18x1.5	24.5	11.5	8.0	22	19	54
GEV-12LR 1.4 WD	708.1171.380.20	400	1/4	18x1.5	27.0	12.0	12.0	22	19	62
◇ GEV-12LR 3.8 WD	708.1171.390.20	400	3/8	18x1.5	27.5	12.5	12.0	22	22	70
GEV-12LR 1.2 WD	708.1171.400.20	400	1/2	18x1.5	28.0	13.0	14.0	22	27	101
GEV-12LR 3.4 WD	708.1171.405.20	400	3/4	18x1.5	29.0	14.0	16.0	22	32	102
GEV-15LR 1.4 WD	708.1171.528.20	400	1/4	22x1.5	28.0	13.0	12.0	27	24	98
GEV-15LR 3.8 WD	708.1171.532.20	400	3/8	22x1.5	28.5	13.5	12.0	27	24	102
◇ GEV-15LR 1.2 WD	708.1171.534.20	400	1/2	22x1.5	29.0	14.0	14.0	27	27	114
GEV-15LR 3.4 WD	708.1171.536.20	400	3/4	22x1.5	30.0	15.0	16.0	27	32	172
GEV-18LR 3.8 WD	708.1171.644.20	400	3/8	26x1.5	31.0	14.5	12.0	32	27	136
◇ GEV-18LR 1.2 WD	708.1171.646.20	400	1/2	26x1.5	31.0	14.5	14.0	32	27	142
GEV-18LR 3.4 WD	708.1171.648.20	400	3/4	26x1.5	31.0	14.5	16.0	32	32	185
GEV-22LR 1.2 WD	708.1171.764.20	250	1/2	30x2.0	32.5	16.5	14.0	36	32	200
◇ GEV-22LR 3.4 WD	708.1171.768.20	250	3/4	30x2.0	33.0	16.5	16.0	36	32	196
GEV-22LR 1.1 WD	708.1171.770.20	250	1	30x2.0	34.0	17.5	18.0	36	41	289
GEV-22LR 5.4 WD	708.1171.771.20	250	1 1/4	30x2.0	35.0	18.5	20.0	36	50	382

Fortsetzung auf nächster rechter Seite

To be continued on next right page

Continuación próxima página derecha

D1=Rohr außen-Ø
M1=metrisches Anschlußgewinde
◇=entspricht Reihe nach DIN 2353

D1=tube outside diameter
M1=metric connecting thread
◇=according to series DIN 2353

D1=Ø exterior del tubo
M1=rosca métrica conexión
◇=según serie DIN 2353

Gerade Einschraubstutzen

Abdichtung durch Profildichtring Form E nach ISO 1179-2

Straight male adaptor connectors

profile sealing ring form E acc. ISO 1179-2

Cuerpos para roscar rectos

cierre hermético mediante junta con perfil forma E según ISO 1179-2

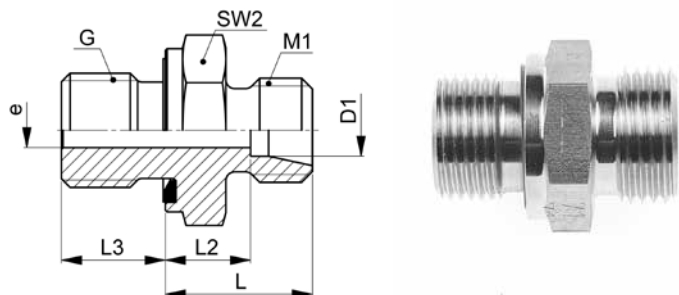

XGEV-..LR WD

Type-D1 G	Mat.-Nr.	PN	G	M1	L	L2	L3	SW2	e	g/Stk
G=Rohrgewinde (zylindrisch)		G=BSP thread (parallel)				G=rosca de conexión (cilíndrica)				
XGEV-28LR 1.2 WD	707.1171.840.20	250	1/2	36x2.0	25.0	17.5	14.0	41	14.0	158
XGEV-28LR 3.4 WD	707.1171.845.20	250	3/4	36x2.0	25.0	17.5	16.0	41	18.0	166
◇ XGEV-28LR 1.1 WD	707.1171.850.20	250	1	36x2.0	25.0	17.5	18.0	41	23.0	169
XGEV-28LR 5.4 WD	707.1171.860.20	250	1 1/4	36x2.0	26.0	18.5	20.0	50	23.0	328
XGEV-35LR 1.2 WD	707.1171.920.20	250	1/2	45x2.0	28.0	17.5	14.0	46	14.0	236
XGEV-35LR 3.4 WD	707.1171.915.20	250	3/4	45x2.0	28.0	17.5	16.0	46	18.0	198
XGEV-35LR 1.1 WD	707.1171.925.20	250	1	45x2.0	28.0	17.5	18.0	46	23.0	248
◇ XGEV-35LR 5.4 WD	707.1171.944.20	250	1 1/4	45x2.0	28.0	17.5	20.0	50	30.0	284
XGEV-35LR 3.2 WD	707.1171.950.20	250	1 1/2	45x2.0	30.0	19.5	22.0	55	30.0	434
XGEV-42LR 1.1 WD	707.1171.980.20	250	1	52x2.0	30.0	19.0	18.0	55	23.0	306
XGEV-42LR 5.4 WD	707.1171.985.20	250	1 1/4	52x2.0	30.0	19.0	20.0	55	30.0	368
◇ XGEV-42LR 3.2 WD	707.1171.992.20	250	1 1/2	52x2.0	30.0	19.0	22.0	55	36.0	356

Dichtungsmaterial: FKM (andere Werkstoffe auf Anfrage)

Sealing material: FKM (other materials on request)

Material de junta tórica: FKM (otros materiales bajo demanda)

ISO 8434-1-SDS-E

D1=Rohr außen-Ø
 M1=metrisches Anschlußgewinde
 e=kleinster Innen-Ø
 ◇=entspricht Reihe nach DIN 2353

D1=tube outside diameter
 M1=metric connecting thread
 e=minimum inside diameter
 ◇=according to series DIN 2353

D1=Ø exterior del tubo
 M1=rosca métrica conexión
 e=Ø interior mínimo
 ◇=según serie DIN 2353

Gerade Einschraubverschraubungen

Abdichtung durch Profildichtring Form E nach ISO 1179-2

Straight male adaptor fittings

profile sealing ring form E acc. ISO 1179-2

Racores para roscar rectos

cierre hermético mediante junta con perfil forma E según ISO 1179-2

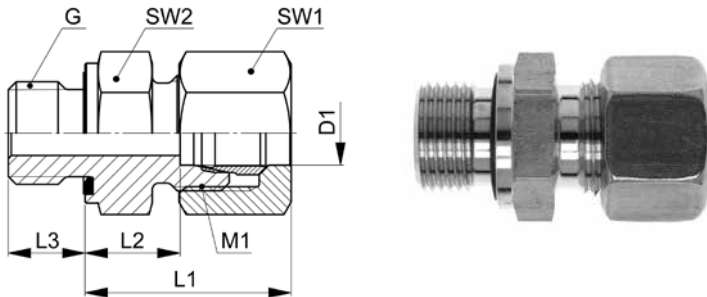

GEV-..LR WD

Type-D1 G	Mat.-Nr.	PN	G	M1	L1	L2	L3	SW1	SW2	g/Stk
G=Rohrgewinde (zylindrisch)		G=BSP thread (parallel)				G=rosca de conexión (cilíndrica)				
GEV-28LR 1.2 WD	708.1171.840.20	250	1/2	36x2.0	34.0	17.5	14.0	41	41	264
GEV-28LR 3.4 WD	708.1171.845.20	250	3/4	36x2.0	34.0	17.5	16.0	41	41	270
◇ GEV-28LR 1.1 WD	708.1171.850.20	250	1	36x2.0	34.0	17.5	18.0	41	41	270
GEV-28LR 5.4 WD	708.1171.860.20	250	1 1/4	36x2.0	35.0	18.5	20.0	41	50	427
GEV-35LR 1.2 WD	708.1171.920.20	250	1/2	45x2.0	39.0	17.5	14.0	50	46	416
GEV-35LR 3.4 WD	708.1171.915.20	250	3/4	45x2.0	39.0	17.5	16.0	50	46	400
GEV-35LR 1.1 WD	708.1171.925.20	250	1	45x2.0	39.0	17.5	18.0	50	46	404
◇ GEV-35LR 5.4 WD	708.1171.944.20	250	1 1/4	45x2.0	39.0	17.5	20.0	50	50	465
GEV-35LR 3.2 WD	708.1171.950.20	250	1 1/2	45x2.0	41.0	19.5	22.0	50	55	594
GEV-42LR 1.1 WD	708.1171.980.20	250	1	52x2.0	42.0	19.0	18.0	60	55	558
GEV-42LR 5.4 WD	708.1171.985.20	250	1 1/4	52x2.0	42.0	19.0	20.0	60	55	626
◇ GEV-42LR 3.2 WD	708.1171.992.20	250	1 1/2	52x2.0	42.0	19.0	22.0	60	55	642

Baumaße sind Ungefährmaße bei angezogener Überwurfmutter.

Sizes are approximate dimensions at tightened nut.

Las medidas son aproximadas con la tuerca de unión apretada.

Dichtungsmaterial: FKM (andere Werkstoffe auf Anfrage)

Sealing material: FKM (other materials on request)

Material de junta tórica: FKM (otros materiales bajo demanda)

ISO 8434-1-SDSC-E

D1=Rohr außen-Ø
M1=metrisches Anschlußgewinde
◇=entspricht Reihe nach DIN 2353

D1=tube outside diameter
M1=metric connecting thread
◇=according to series DIN 2353

D1=Ø exterior del tubo
M1=rosca métrica conexión
◇=según serie DIN 2353

Gerade Einschraubstutzen

Abdichtung durch Dichtkante Form B nach DIN 3852-2

Straight male adaptor connectors

sealing edge form B acc. DIN 3852-2

Cuerpos para roscar rectos

cierre hermético mediante borde de obturación forma B según DIN 3852-2

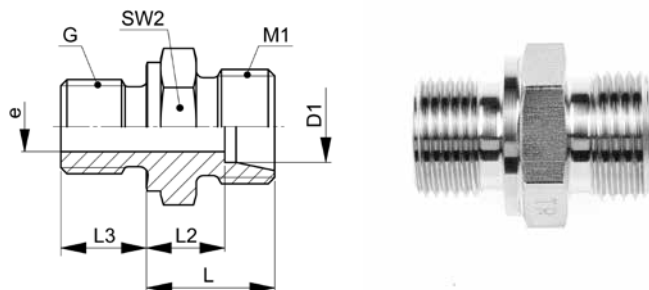

XGEV-..SR

Type-D1 G	Mat.-Nr.	PN	G	M1	L	L2	L3	SW2	e	g/Stk
G=Rohrgewinde (zylindrisch)		G=BSP thread (parallel)			G=rosca de conexión (cilíndrica)					
XGEV-06SR 1.8	706.1141.100.30	800	1/8	14x1.5	19.5	12.5	8.0	14	4.0	20
◇ XGEV-06SR 1.4	706.1141.110.30	800	1/4	14x1.5	20.0	13.0	12.0	19	4.0	36
XGEV-06SR 3.8	706.1141.120.30	800	3/8	14x1.5	22.5	15.5	12.0	22	4.0	58
XGEV-06SR 1.2	706.1141.125.30	800	1/2	14x1.5	25.0	18.0	12.0	27	4.0	100
XGEV-06SR 3.4	706.1141.126.30	800	3/4	14x1.5	27.0	20.0	12.0	32	4.0	123
XGEV-08SR 1.8	706.1141.160.30	800	1/8	16x1.5	21.5	14.5	12.0	17	4.0	21
◇ XGEV-08SR 1.4	706.1141.170.30	800	1/4	16x1.5	22.0	15.0	12.0	19	5.0	42
XGEV-08SR 3.8	706.1141.180.30	800	3/8	16x1.5	22.5	15.5	12.0	22	5.0	60
XGEV-08SR 1.2	706.1141.185.30	800	1/2	16x1.5	25.0	18.0	14.0	27	5.0	100
XGEV-10SR 1.8	706.1141.265.30	800	1/8	18x1.5	21.5	14.0	8.0	19	4.0	28
XGEV-10SR 1.4	706.1141.270.30	800	1/4	18x1.5	22.0	14.5	12.0	19	5.0	45
◇ XGEV-10SR 3.8	706.1141.280.30	800	3/8	18x1.5	22.5	15.0	12.0	22	7.0	48
XGEV-10SR 1.2	706.1141.285.30	800	1/2	18x1.5	25.0	17.5	14.0	27	7.0	98
XGEV-10SR 3.4	706.1141.290.30	800	3/4	18x1.5	27.0	19.5	16.0	32	7.0	118
XGEV-12SR 1.4	706.1141.380.30	630	1/4	20x1.5	24.0	16.5	12.0	22	5.0	56
◇ XGEV-12SR 3.8	706.1141.390.30	630	3/8	20x1.5	24.5	17.0	12.0	22	8.0	64
XGEV-12SR 1.2	706.1141.400.30	630	1/2	20x1.5	25.0	17.5	14.0	27	8.0	99
XGEV-12SR 3.4	706.1141.405.30	630	3/4	20x1.5	25.0	17.5	16.0	32	8.0	154
XGEV-14SR 1.4	706.1141.500.30	630	1/4	22x1.5	24.0	16.0	12.0	24	5.0	62
XGEV-14SR 3.8	706.1141.502.30	630	3/8	22x1.5	26.5	18.5	12.0	24	8.0	76
XGEV-14SR 1.2	706.1141.504.30	630	1/2	22x1.5	27.0	19.0	14.0	27	10.0	99
XGEV-14SR 3.4	706.1141.506.30	630	3/4	22x1.5	29.0	21.0	16.0	32	10.0	164
XGEV-14SR 1.1	706.1141.510.30	630	1	22x1.5	31.0	23.0	18.0	41	10.0	188
XGEV-16SR 3.8	706.1141.564.30	630	3/8	24x1.5	26.5	18.0	12.0	27	8.0	92
◇ XGEV-16SR 1.2	706.1141.566.30	630	1/2	24x1.5	27.0	18.5	14.0	27	12.0	94
XGEV-16SR 3.4	706.1141.568.30	630	3/4	24x1.5	29.0	20.5	16.0	32	12.0	152
XGEV-16SR 1.1	706.1141.570.30	630	1	24x1.5	31.0	22.5	18.0	41	12.0	290
XGEV-20SR 1.2	706.1141.706.30	420	1/2	30x2.0	31.0	20.5	14.0	32	12.0	144
◇ XGEV-20SR 3.4	706.1141.708.30	420	3/4	30x2.0	31.0	20.5	16.0	32	16.0	155
XGEV-20SR 1.1	706.1141.712.30	420	1	30x2.0	33.0	22.5	18.0	41	16.0	282
XGEV-20SR 5.4	706.1141.715.30	420	1 1/4	30x2.0	33.0	22.5	20.0	50	16.0	460
XGEV-20SR 3.2	706.1141.717.30	420	1 1/2	30x2.0	36.0	25.5	22.0	55	16.0	664

Fortsetzung auf nächster linker Seite

To be continued on next left page

Continuación próxima página izquierda

D1=Rohr außen-Ø
M1=metrisches Anschlußgewinde
e=kleinster Innen-Ø
◇=entspricht Reihe nach DIN 2353

D1=tube outside diameter
M1=metric connecting thread
e=minimum inside diameter
◇=according to series DIN 2353

D1=Ø exterior del tubo
M1=rosca métrica conexión
e=Ø interior mínimo
◇=según serie DIN 2353

Gerade Einschraubverschraubungen

Abdichtung durch Dichtkante Form B nach DIN 3852-2

Straight male adaptor fittings

sealing edge form B acc. DIN 3852-2

Racores para roscar rectos

cierre hermético mediante borde de obturación forma B según DIN 3852-2

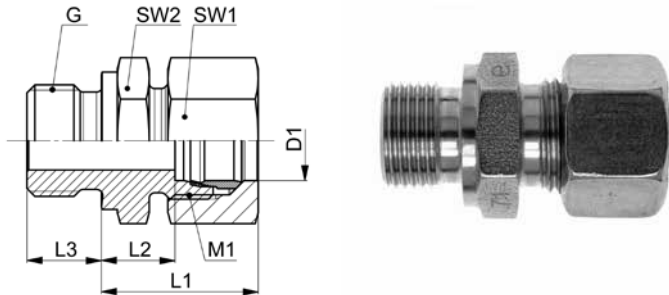

GEV-..SR

Type-D1 G	Mat.-Nr.	PN	G	M1	L1	L2	L3	SW1	SW2	g/Stk
G=Rohrgewinde (zylindrisch)		G=BSP thread (parallel)				G=rosca de conexión (cilíndrica)				
GEV-06SR 1.8	708.1141.100.30	800	1/8	14x1.5	27.5	12.5	8.0	17	14	40
◇ GEV-06SR 1.4	708.1141.110.30	800	1/4	14x1.5	28.0	13.0	12.0	17	19	54
GEV-06SR 3.8	708.1141.120.30	800	3/8	14x1.5	30.5	15.5	12.0	17	22	63
GEV-06SR 1.2	708.1141.125.30	800	1/2	14x1.5	33.0	18.0	12.0	17	27	107
GEV-06SR 3.4	708.1141.126.30	800	3/4	14x1.5	35.0	20.0	12.0	17	32	152
GEV-08SR 1.8	708.1141.160.30	800	1/8	16x1.5	29.5	14.5	12.0	19	17	58
◇ GEV-08SR 1.4	708.1141.170.30	800	1/4	16x1.5	30.0	15.0	12.0	19	19	63
GEV-08SR 3.8	708.1141.180.30	800	3/8	16x1.5	30.5	15.5	12.0	19	22	82
GEV-08SR 1.2	708.1141.185.30	800	1/2	16x1.5	33.0	18.0	14.0	19	27	108
GEV-10SR 1.8	708.1141.265.30	800	1/8	18x1.5	30.5	14.0	8.0	22	19	77
GEV-10SR 1.4	708.1141.270.30	800	1/4	18x1.5	31.0	14.5	12.0	22	19	73
◇ GEV-10SR 3.8	708.1141.280.30	800	3/8	18x1.5	31.5	15.0	12.0	22	22	89
GEV-10SR 1.2	708.1141.285.30	800	1/2	18x1.5	34.0	17.5	14.0	22	27	125
GEV-10SR 3.4	708.1141.290.30	800	3/4	18x1.5	36.0	19.5	16.0	22	32	208
GEV-12SR 1.4	708.1141.380.30	630	1/4	20x1.5	33.0	16.5	12.0	24	22	91
◇ GEV-12SR 3.8	708.1141.390.30	630	3/8	20x1.5	33.5	17.0	12.0	24	22	100
GEV-12SR 1.2	708.1141.400.30	630	1/2	20x1.5	34.0	17.5	14.0	24	27	135
GEV-12SR 3.4	708.1141.405.30	630	3/4	20x1.5	34.0	17.5	16.0	24	32	192
GEV-14SR 1.4	708.1141.500.30	630	1/4	22x1.5	34.0	16.0	12.0	27	24	118
GEV-14SR 3.8	708.1141.502.30	630	3/8	22x1.5	36.5	18.5	12.0	27	24	130
GEV-14SR 1.2	708.1141.504.30	630	1/2	22x1.5	37.0	19.0	14.0	27	27	154
GEV-14SR 3.4	708.1141.506.30	630	3/4	22x1.5	39.0	21.0	16.0	27	32	195
GEV-14SR 1.1	708.1141.510.30	630	1	22x1.5	41.0	23.0	18.0	27	41	350
GEV-16SR 3.8	708.1141.564.30	630	3/8	24x1.5	36.5	18.0	12.0	30	27	156
◇ GEV-16SR 1.2	708.1141.566.30	630	1/2	24x1.5	37.0	18.5	14.0	30	27	161
GEV-16SR 3.4	708.1141.568.30	630	3/4	24x1.5	39.0	20.5	16.0	30	32	240
GEV-16SR 1.1	708.1141.570.30	630	1	24x1.5	41.0	22.5	18.0	30	41	359
GEV-20SR 1.2	708.1141.706.30	420	1/2	30x2.0	42.0	20.5	14.0	36	32	245
◇ GEV-20SR 3.4	708.1141.708.30	420	3/4	30x2.0	42.0	20.5	16.0	36	32	277
GEV-20SR 1.1	708.1141.712.30	420	1	30x2.0	44.0	22.5	18.0	36	41	387
GEV-20SR 5.4	708.1141.715.30	420	1 1/4	30x2.0	44.0	22.5	20.0	36	50	574
GEV-20SR 3.2	708.1141.717.30	420	1 1/2	30x2.0	47.0	25.5	22.0	36	55	778

Fortsetzung auf nächster rechter Seite

To be continued on next right page

Continuación próxima página derecha

D1=Rohr außen-Ø
M1=metrisches Anschlußgewinde
◇=entspricht Reihe nach DIN 2353

D1=tube outside diameter
M1=metric connecting thread
◇=according to series DIN 2353

D1=Ø exterior del tubo
M1=rosca métrica conexión
◇=según serie DIN 2353

Gerade Einschraubstutzen

Abdichtung durch Dichtkante Form B nach DIN 3852-2

Straight male adaptor connectors

sealing edge form B acc. DIN 3852-2

Cuerpos para roscar rectos

cierre hermético mediante borde de obturación forma B según DIN 3852-2

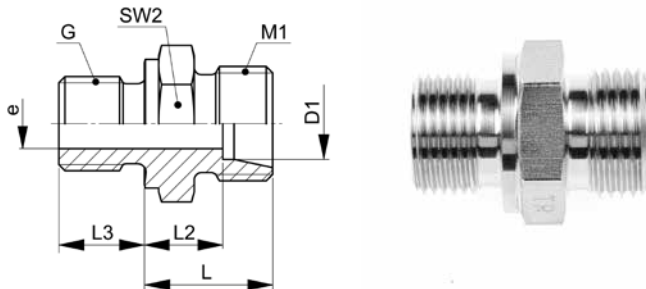

XGEV-..SR

Type-D1 G	Mat.-Nr.	PN	G	M1	L	L2	L3	SW2	e	g/Stk
G=Rohrgewinde (zylindrisch)		G=BSP thread (parallel)				G=rosca de conexión (cilíndrica)				
XGEV-25SR 1.2	706.1141.800.30	420	1/2	36x2.0	32.0	20.0	14.0	41	12.0	220
XGEV-25SR 3.4	706.1141.805.30	420	3/4	36x2.0	35.0	23.0	16.0	41	16.0	258
◇ XGEV-25SR 1.1	706.1141.810.30	420	1	36x2.0	35.0	23.0	18.0	41	20.0	273
XGEV-25SR 5.4	706.1141.815.30	420	1 1/4	36x2.0	35.0	23.0	20.0	50	20.0	452
XGEV-25SR 3.2	706.1141.820.30	420	1 1/2	36x2.0	38.0	26.0	22.0	55	20.0	549
XGEV-30SR 3.4	706.1141.895.30	420	3/4	42x2.0	37.0	23.5	16.0	46	16.0	318
XGEV-30SR 1.1	706.1141.900.30	420	1	42x2.0	37.0	23.5	18.0	46	20.0	356
◇ XGEV-30SR 5.4	706.1141.902.30	420	1 1/4	42x2.0	37.0	23.5	20.0	50	25.0	430
XGEV-30SR 3.2	706.1141.905.30	420	1 1/2	42x2.0	40.0	26.5	22.0	55	25.0	616
XGEV-38SR 5.4	706.1141.954.30	420	1 1/4	52x2.0	42.0	26.0	20.0	55	25.0	588
◇ XGEV-38SR 3.2	706.1141.953.30	420	1 1/2	52x2.0	42.0	26.0	22.0	55	32.0	579

ISO 8434-1-SDS-B

D1=Rohraußen-Ø
 M1=metrisches Anschlußgewinde
 e=kleinster Innen-Ø
 ◇=entspricht Reihe nach DIN 2353

D1=tube outside diameter
 M1=metric connecting thread
 e=minimum inside diameter
 ◇=according to series DIN 2353

D1=Ø exterior del tubo
 M1=rosca métrica conexión
 e=Ø interior mínimo
 ◇=según serie DIN 2353

Gerade Einschraubverschraubungen

Abdichtung durch Dichtkante Form B nach DIN 3852-2

Straight male adaptor fittings

sealing edge form B acc. DIN 3852-2

Racores para roscar rectos

cierre hermético mediante borde de obturación forma B según DIN 3852-2

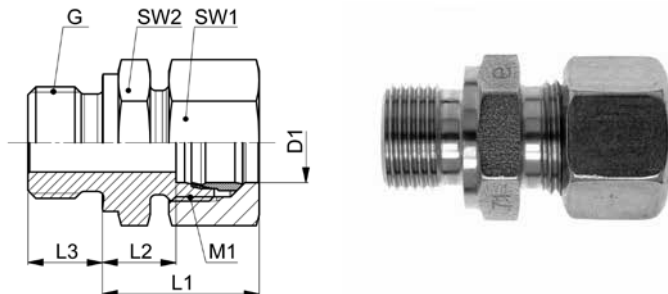

GEV-..SR

Type-D1 G	Mat.-Nr.	PN	G	M1	L1	L2	L3	SW1	SW2	g/Stk
G=Rohrgewinde (zylindrisch)		G=BSP thread (parallel)				G=rosca de conexión (cilíndrica)				
GEV-25SR 1.2	708.1141.800.30	420	1/2	36x2.0	44.0	20.0	14.0	46	41	444
GEV-25SR 3.4	708.1141.805.30	420	3/4	36x2.0	47.0	23.0	16.0	46	41	455
◇ GEV-25SR 1.1	708.1141.810.30	420	1	36x2.0	47.0	23.0	18.0	46	41	494
GEV-25SR 5.4	708.1141.815.30	420	1 1/4	36x2.0	47.0	23.0	20.0	46	50	674
GEV-25SR 3.2	708.1141.820.30	420	1 1/2	36x2.0	50.0	26.0	22.0	46	55	582
GEV-30SR 3.4	708.1141.895.30	420	3/4	42x2.0	50.0	23.5	16.0	50	46	611
GEV-30SR 1.1	708.1141.900.30	420	1	42x2.0	50.0	23.5	18.0	50	46	630
◇ GEV-30SR 5.4	708.1141.902.30	420	1 1/4	42x2.0	50.0	23.5	20.0	50	50	670
GEV-30SR 3.2	708.1141.905.30	420	1 1/2	42x2.0	53.0	26.5	22.0	50	55	979
GEV-38SR 5.4	708.1141.954.30	420	1 1/4	52x2.0	55.0	26.0	20.0	60	55	920
◇ GEV-38SR 3.2	708.1141.953.30	420	1 1/2	52x2.0	55.0	26.0	22.0	60	55	935

Baumaße sind Ungefährmaße bei angezogener Überwurfmutter.

Sizes are approximate dimensions at tightened nuts.

Las medidas son aproximadas con la tuerca de unión apretada.

ISO 8434-1-SDSC-B

D1=Rohr außen-Ø
M1=metrisches Anschlußgewinde
◇=entspricht Reihe nach DIN 2353

D1=tube outside diameter
M1=metric connecting thread
◇=according to series DIN 2353

D1=Ø exterior del tubo
M1=rosca métrica conexión
◇=según serie DIN 2353

Gerade Einschraubstutzen

Abdichtung durch Profildichtring Form E nach ISO 1179-2

Straight male adaptor connectors

profile sealing ring form E acc. ISO 1179-2

Cuerpos para roscar rectos

cierre hermético mediante junta con perfil forma E según ISO 1179-2

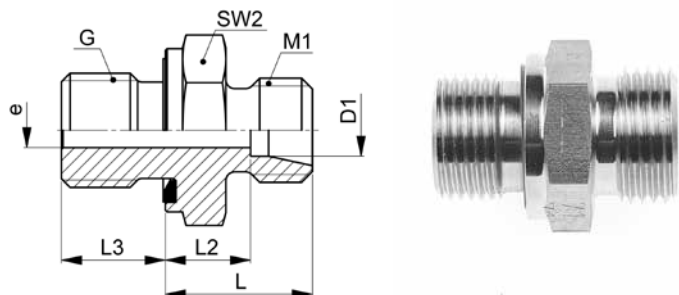

XGEV-..SR WD

Type-D1 G	Mat.-Nr.	PN	G	M1	L	L2	L3	SW2	e	g/Stk
G=Rohrgewinde (zylindrisch)		G=BSP thread (parallel)						G=rosca de conexión (cilíndrica)		
XGEV-06SR 1.8 WD	707.1171.100.30	800	1/8	14x1.5	19.5	12.5	8.0	14	4.0	24
◇ XGEV-06SR 1.4 WD	707.1171.110.30	800	1/4	14x1.5	20.0	13.0	12.0	19	4.0	36
XGEV-06SR 3.8 WD	707.1171.120.30	800	3/8	14x1.5	22.5	15.5	12.0	22	4.0	54
XGEV-06SR 1.2 WD	707.1171.125.30	800	1/2	14x1.5	25.0	18.0	14.0	27	4.0	100
XGEV-06SR 3.4 WD	707.1171.126.30	800	3/4	14x1.5	27.0	20.0	16.0	32	4.0	166
XGEV-08SR 1.8 WD	707.1171.160.30	800	1/8	16x1.5	21.5	14.5	8.0	17	4.0	40
◇ XGEV-08SR 1.4 WD	707.1171.170.30	800	1/4	16x1.5	22.0	15.0	12.0	19	5.0	41
XGEV-08SR 3.8 WD	707.1171.180.30	800	3/8	16x1.5	22.5	15.5	12.0	22	5.0	58
XGEV-08SR 1.2 WD	707.1171.185.30	800	1/2	16x1.5	25.0	18.0	14.0	27	5.0	100
XGEV-10SR 1.8 WD	707.1171.265.30	800	1/8	18x1.5	21.5	14.0	8.0	19	4.0	32
XGEV-10SR 1.4 WD	707.1171.270.30	800	1/4	18x1.5	22.0	14.5	12.0	19	5.0	44
◇ XGEV-10SR 3.8 WD	707.1171.280.30	800	3/8	18x1.5	22.5	15.0	12.0	22	7.0	56
XGEV-10SR 1.2 WD	707.1171.285.30	800	1/2	18x1.5	25.0	17.5	14.0	27	7.0	96
XGEV-10SR 3.4 WD	707.1171.290.30	800	3/4	18x1.5	27.0	19.5	16.0	32	7.0	115
XGEV-12SR 1.4 WD	707.1171.380.30	630	1/4	20x1.5	24.0	16.5	12.0	22	5.0	58
◇ XGEV-12SR 3.8 WD	707.1171.390.30	630	3/8	20x1.5	24.5	17.0	12.0	22	8.0	64
XGEV-12SR 1.2 WD	707.1171.400.30	630	1/2	20x1.5	25.0	17.5	14.0	27	8.0	98
XGEV-12SR 3.4 WD	707.1171.405.30	630	3/4	20x1.5	25.0	17.5	16.0	32	8.0	160
XGEV-14SR 1.4 WD	707.1171.500.30	630	1/4	22x1.5	24.0	16.0	12.0	24	5.0	66
XGEV-14SR 3.8 WD	707.1171.502.30	630	3/8	22x1.5	26.5	18.5	12.0	24	8.0	112
XGEV-14SR 1.2 WD	707.1171.504.30	630	1/2	22x1.5	27.0	19.0	14.0	27	10.0	99
XGEV-14SR 3.4 WD	707.1171.506.30	630	3/4	22x1.5	29.0	21.0	16.0	32	10.0	164
XGEV-16SR 3.8 WD	707.1171.564.30	630	3/8	24x1.5	26.5	18.0	12.0	27	8.0	88
◇ XGEV-16SR 1.2 WD	707.1171.566.30	630	1/2	24x1.5	27.0	18.5	14.0	27	12.0	94
XGEV-16SR 3.4 WD	707.1171.568.30	630	3/4	24x1.5	29.0	20.5	16.0	32	12.0	155
XGEV-16SR 1.1 WD	707.1171.570.30	630	1	24x1.5	31.0	22.5	18.0	41	12.0	275
XGEV-20SR 1.2 WD	707.1171.706.30	420	1/2	30x2.0	31.0	20.5	14.0	32	12.0	144
◇ XGEV-20SR 3.4 WD	707.1171.708.30	420	3/4	30x2.0	31.0	20.5	16.0	32	16.0	152
XGEV-20SR 1.1 WD	707.1171.712.30	420	1	30x2.0	33.0	22.5	18.0	41	16.0	296
XGEV-20SR 5.4 WD	707.1171.715.30	420	1 1/4	30x2.0	33.0	22.5	20.0	50	16.0	458
XGEV-20SR 3.2 WD	707.1171.717.30	420	1 1/2	30x2.0	36.0	25.5	22.0	55	16.0	664

Fortsetzung auf nächster linker Seite

To be continued on next left page

Continuación próxima página izquierda

D1=Rohr außen-Ø
M1=metrisches Anschlußgewinde
e=kleinster Innen-Ø
◇=entspricht Reihe nach DIN 2353

D1=tube outside diameter
M1=metric connecting thread
e=minimum inside diameter
◇=according to series DIN 2353

D1=Ø exterior del tubo
M1=rosca métrica conexión
e=Ø interior mínimo
◇=según serie DIN 2353

Gerade Einschraubverschraubungen

Abdichtung durch Profildichtring Form E nach ISO 1179-2

Straight male adaptor fittings

profile sealing ring form E acc. ISO 1179-2

Racores para roscar rectos

cierre hermético mediante junta con perfil forma E según ISO 1179-2

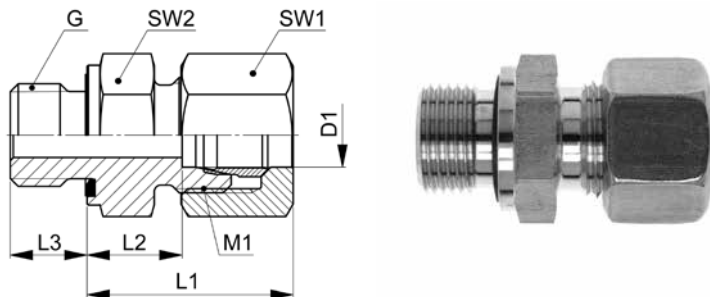

GEV-..SR WD

Type-D1 G	Mat.-Nr.	PN	G	M1	L1	L2	L3	SW1	SW2	g/Stk
G=Rohrgewinde (zylindrisch)		G=BSP thread (parallel)				G=rosca de conexión (cilíndrica)				
GEV-06SR 1.8 WD	708.1171.100.30	800	1/8	14x1.5	27.5	12.5	8.0	17	14	40
◇ GEV-06SR 1.4 WD	708.1171.110.30	800	1/4	14x1.5	28.0	13.0	12.0	17	19	54
GEV-06SR 3.8 WD	708.1171.120.30	800	3/8	14x1.5	30.5	15.5	12.0	17	22	63
GEV-06SR 1.2 WD	708.1171.125.30	800	1/2	14x1.5	33.0	18.0	14.0	17	27	107
GEV-06SR 3.4 WD	708.1171.126.30	800	3/4	14x1.5	35.0	20.0	16.0	17	32	184
GEV-08SR 1.8 WD	708.1171.160.30	800	1/8	16x1.5	29.5	14.5	8.0	19	17	58
◇ GEV-08SR 1.4 WD	708.1171.170.30	800	1/4	16x1.5	30.0	15.0	12.0	19	19	63
GEV-08SR 3.8 WD	708.1171.180.30	800	3/8	16x1.5	30.5	15.5	12.0	19	22	82
GEV-08SR 1.2 WD	708.1171.185.30	800	1/2	16x1.5	33.0	18.0	14.0	19	27	108
GEV-10SR 1.8 WD	708.1171.265.30	800	1/8	18x1.5	30.5	14.0	8.0	22	19	48
GEV-10SR 1.4 WD	708.1171.270.30	800	1/4	18x1.5	31.0	14.5	12.0	22	19	73
◇ GEV-10SR 3.8 WD	708.1171.280.30	800	3/8	18x1.5	31.5	15.0	12.0	22	22	89
GEV-10SR 1.2 WD	708.1171.285.30	800	1/2	18x1.5	34.0	17.5	14.0	22	27	125
GEV-10SR 3.4 WD	708.1171.290.30	800	3/4	18x1.5	36.0	19.5	16.0	22	32	166
GEV-12SR 1.4 WD	708.1171.380.30	630	1/4	20x1.5	33.0	16.5	12.0	24	22	91
◇ GEV-12SR 3.8 WD	708.1171.390.30	630	3/8	20x1.5	33.5	17.0	12.0	24	22	100
GEV-12SR 1.2 WD	708.1171.400.30	630	1/2	20x1.5	34.0	17.5	14.0	24	27	135
GEV-12SR 3.4 WD	708.1171.405.30	630	3/4	20x1.5	34.0	17.5	16.0	24	32	192
GEV-14SR 1.4 WD	708.1171.500.30	630	1/4	22x1.5	34.0	16.0	12.0	27	24	120
GEV-14SR 3.8 WD	708.1171.502.30	630	3/8	22x1.5	36.5	18.5	12.0	27	24	130
GEV-14SR 1.2 WD	708.1171.504.30	630	1/2	22x1.5	37.0	19.0	14.0	27	27	154
GEV-14SR 3.4 WD	708.1171.506.30	630	3/4	22x1.5	39.0	21.0	16.0	27	32	195
GEV-16SR 3.8 WD	708.1171.564.30	630	3/8	24x1.5	36.5	18.0	12.0	30	27	156
◇ GEV-16SR 1.2 WD	708.1171.566.30	630	1/2	24x1.5	37.0	18.5	14.0	30	27	161
GEV-16SR 3.4 WD	708.1171.568.30	630	3/4	24x1.5	39.0	20.5	16.0	30	32	226
GEV-16SR 1.1 WD	708.1171.570.30	630	1	24x1.5	41.0	22.5	18.0	30	41	348
GEV-20SR 1.2 WD	708.1171.706.30	420	1/2	30x2.0	42.0	20.5	14.0	36	32	245
◇ GEV-20SR 3.4 WD	708.1171.708.30	420	3/4	30x2.0	42.0	20.5	16.0	36	32	277
GEV-20SR 1.1 WD	708.1171.712.30	420	1	30x2.0	44.0	22.5	18.0	36	41	387
GEV-20SR 5.4 WD	708.1171.715.30	420	1 1/4	30x2.0	44.0	22.5	20.0	36	50	574
GEV-20SR 3.2 WD	708.1171.717.30	420	1 1/2	30x2.0	47.0	25.5	22.0	36	55	782

Fortsetzung auf nächster rechter Seite

To be continued on next right page

Continuación próxima página derecha

D1=Rohr außen-Ø
M1=metrisches Anschlußgewinde
◇=entspricht Reihe nach DIN 2353

D1=tube outside diameter
M1=metric connecting thread
◇=according to series DIN 2353

D1=Ø exterior del tubo
M1=rosca métrica conexión
◇=según serie DIN 2353

Gerade Einschraubstutzen

Abdichtung durch Profildichtring Form E nach ISO 1179-2

Straight male adaptor connectors

profile sealing ring form E acc. ISO 1179-2

Cuerpos para roscar rectos

cierre hermético mediante junta con perfil forma E según ISO 1179-2

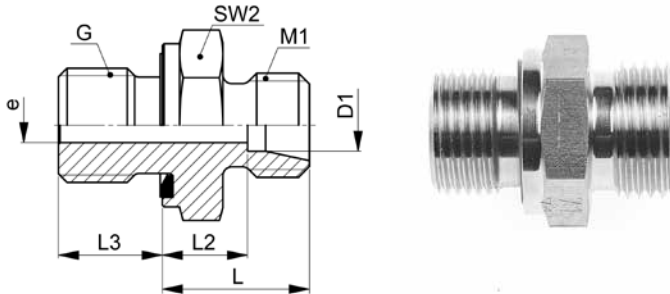

XGEV-..SR WD

Type-D1 G	Mat.-Nr.	PN	G	M1	L	L2	L3	SW2	e	g/Stk
G=Rohrgewinde (zylindrisch)		G=BSP thread (parallel)				G=rosca de conexión (cilíndrica)				
XGEV-25SR 1.2 WD	707.1171.800.30	420	1/2	36x2.0	32.0	20.0	14.0	41	12.0	220
XGEV-25SR 3.4 WD	707.1171.805.30	420	3/4	36x2.0	35.0	23.0	16.0	41	16.0	254
◇ XGEV-25SR 1.1 WD	707.1171.810.30	420	1	36x2.0	35.0	23.0	18.0	41	20.0	270
XGEV-25SR 5.4 WD	707.1171.815.30	420	1 1/4	36x2.0	35.0	23.0	20.0	50	20.0	450
XGEV-25SR 3.2 WD	707.1171.820.30	420	1 1/2	36x2.0	38.0	26.0	22.0	55	20.0	648
XGEV-30SR 3.4 WD	707.1171.895.30	420	3/4	42x2.0	37.0	23.5	16.0	46	16.0	318
XGEV-30SR 1.1 WD	707.1171.900.30	420	1	42x2.0	37.0	23.5	18.0	46	20.0	352
◇ XGEV-30SR 5.4 WD	707.1171.902.30	420	1 1/4	42x2.0	37.0	23.5	20.0	50	25.0	426
XGEV-30SR 3.2 WD	707.1171.905.30	420	1 1/2	42x2.0	40.0	26.5	22.0	55	25.0	620
XGEV-38SR 1.1 WD	707.1171.960.30	420	1	52x2.0	39.0	26.0	18.0	55	20.0	580
XGEV-38SR 5.4 WD	707.1171.954.30	420	1 1/4	52x2.0	39.0	23.0	20.0	55	25.0	520
◇ XGEV-38SR 3.2 WD	707.1171.953.30	420	1 1/2	52x2.0	42.0	26.0	22.0	55	32.0	640

Dichtungsmaterial: FKM (andere Werkstoffe auf Anfrage)

Sealing material: FKM (other materials on request)

Material de junta tórica: FKM (otros materiales bajo demanda)

ISO 8434-1-SDS-E

D1=Rohr außen-Ø
 M1=metrisches Anschlußgewinde
 e=kleinster Innen-Ø
 ◇=entspricht Reihe nach DIN 2353

D1=tube outside diameter
 M1=metric connecting thread
 e=minimum inside diameter
 ◇=according to series DIN 2353

D1=Ø exterior del tubo
 M1=rosca métrica conexión
 e=Ø interior mínimo
 ◇=según serie DIN 2353

Gerade Einschraubverschraubungen

Abdichtung durch Profildichtring Form E nach ISO 1179-2

Straight male adaptor fittings

profile sealing ring form E acc. ISO 1179-2

Racores para roscar rectos

cierre hermético mediante junta con perfil forma E según ISO 1179-2

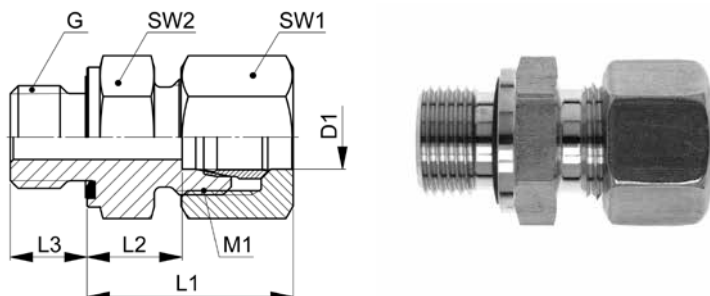

GEV-..SR WD

Type-D1 G	Mat.-Nr.	PN	G	M1	L1	L2	L3	SW1	SW2	g/Stk
G=Rohrgewinde (zylindrisch)		G=BSP thread (parallel)				G=rosca de conexión (cilíndrica)				
GEV-25SR 1.2 WD	708.1171.800.30	420	1/2	36x2.0	44.0	20.0	14.0	46	41	456
GEV-25SR 3.4 WD	708.1171.805.30	420	3/4	36x2.0	47.0	23.0	16.0	46	41	455
◇ GEV-25SR 1.1 WD	708.1171.810.30	420	1	36x2.0	47.0	23.0	18.0	46	41	494
GEV-25SR 5.4 WD	708.1171.815.30	420	1 1/4	36x2.0	47.0	23.0	20.0	46	50	674
GEV-25SR 3.2 WD	708.1171.820.30	420	1 1/2	36x2.0	50.0	26.0	22.0	46	55	872
GEV-30SR 3.4 WD	708.1171.895.30	420	3/4	42x2.0	50.0	23.5	16.0	50	46	568
GEV-30SR 1.1 WD	708.1171.900.30	420	1	42x2.0	50.0	23.5	18.0	50	46	580
◇ GEV-30SR 5.4 WD	708.1171.902.30	420	1 1/4	42x2.0	50.0	23.5	20.0	50	50	670
GEV-30SR 3.2 WD	708.1171.905.30	420	1 1/2	42x2.0	53.0	26.5	22.0	50	55	870
GEV-38SR 1.1 WD	708.1171.960.30	420	1	52x2.0	54.0	26.0	18.0	60	55	935
GEV-38SR 5.4 WD	708.1171.954.30	420	1 1/4	52x2.0	54.0	23.0	20.0	60	55	920
◇ GEV-38SR 3.2 WD	708.1171.953.30	420	1 1/2	52x2.0	57.0	26.0	22.0	60	55	935

Baumaße sind Ungefährmaße bei angezogener Überwurfmutter.

Sizes are approximate dimensions at tightened nut.

Las medidas son aproximadas con la tuerca de unión apretada.

Dichtungsmaterial: FKM (andere Werkstoffe auf Anfrage)

Sealing material: FKM (other materials on request)

Material de junta tórica: FKM (otros materiales bajo demanda)

ISO 8434-1-SDSC-E

D1=Rohr außen-Ø
M1=metrisches Anschlußgewinde
◇=entspricht Reihe nach DIN 2353

D1=tube outside diameter
M1=metric connecting thread
◇=according to series DIN 2353

D1=Ø exterior del tubo
M1=rosca métrica conexión
◇=según serie DIN 2353

Gerade Einschraubstutzen

Abdichtung durch Dichtkante Form B nach DIN 3852-2

Straight male adaptor connectors

sealing edge form B acc. DIN 3852-2

Cuerpos para roscar rectos

cierre hermético mediante borde de obturación forma B según DIN 3852-2

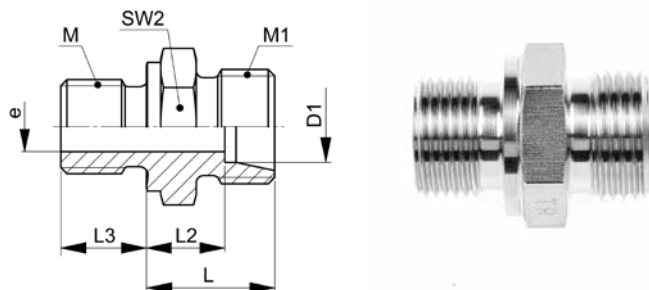

XGEV-..LM

Type-D1 M	Mat.-Nr.	PN	M	M1	L	L2	L3	SW2	e	g/Stk
M=metrisches Gewinde (zylindrisch)		M=metric thread (parallel)				M=rosca métrica (cilíndrica)				
◇ XGEV-06LM 10x1,0	706.1143.180.20	500	10x1.0	12x1.5	15.0	8.5	8.0	14	4.0	15
XGEV-06LM 12x1,5	706.1143.190.20	500	12x1.5	12x1.5	17.0	10.0	12.0	17	4.0	24
◇ XGEV-08LM 12x1,5	706.1143.240.20	500	12x1.5	14x1.5	17.0	10.0	12.0	17	6.0	22
XGEV-08LM 14x1,5	706.1143.245.20	500	14x1.5	14x1.5	17.0	10.0	12.0	19	6.0	28
XGEV-08LM 18x1,5	706.1143.255.20	500	18x1.5	14x1.5	18.5	11.5	12.0	24	6.0	54
XGEV-10LM 10x1,0	706.1143.270.20	500	10x1.0	16x1.5	17.5	10.5	8.0	17	4.0	20
XGEV-10LM 12x1,5	706.1143.275.20	500	12x1.5	16x1.5	18.0	11.0	12.0	17	6.0	24
◇ XGEV-10LM 14x1,5	706.1143.280.20	500	14x1.5	16x1.5	18.0	11.0	12.0	19	7.0	30
XGEV-10LM 16x1,5	706.1143.285.20	500	16x1.5	16x1.5	19.5	12.5	12.0	22	8.0	42
XGEV-10LM 18x1,5	706.1143.288.20	500	18x1.5	16x1.5	19.5	12.5	12.0	24	8.0	50
XGEV-10LM 22x1,5	706.1143.290.20	500	22x1.5	16x1.5	21.0	14.0	14.0	27	8.0	85
XGEV-12LM 14x1,5	706.1143.327.20	400	14x1.5	18x1.5	19.0	12.0	12.0	19	7.0	34
◇ XGEV-12LM 16x1,5	706.1143.330.20	400	16x1.5	18x1.5	19.5	12.5	12.0	22	9.0	41
XGEV-12LM 18x1,5	706.1143.333.20	400	18x1.5	18x1.5	19.5	12.5	12.0	24	9.0	50
XGEV-12LM 22x1,5	706.1143.338.20	400	22x1.5	18x1.5	21.0	14.0	14.0	27	9.0	80
◇ XGEV-15LM 18x1,5	706.1143.390.20	400	18x1.5	26x1.5	20.5	13.5	12.0	24	11.0	50
XGEV-15LM 22x1,5	706.1143.395.20	400	22x1.5	22x1.5	22.0	15.0	14.0	27	12.0	76
XGEV-18LM 18x1,5	706.1143.455.20	400	18x1.5	26x1.5	22.5	15.0	12.0	27	11.0	80
◇ XGEV-18LM 22x1,5	706.1143.460.20	400	22x1.5	26x1.5	22.0	14.5	14.0	27	14.0	76
XGEV-18LM 26x1,5	706.1143.465.20	400	26x1.5	26x1.5	22.0	14.5	16.0	32	14.0	88
XGEV-22LM 18x1,5	706.1143.525.20	250	18x1.5	30x2.0	25.5	18.0	12.0	32	11.0	119
XGEV-22LM 22x1,5	706.1143.530.20	250	22x1.5	30x2.0	26.0	18.5	14.0	32	14.0	112
◇ XGEV-22LM 26x1,5	706.1143.535.20	250	26x1.5	30x2.0	24.0	16.5	16.0	32	18.0	104
◇ XGEV-28LM 33x2,0	706.1143.570.20	250	33x2.0	36x2.0	25.0	17.5	18.0	41	23.0	168
◇ XGEV-35LM 42x2,0	706.1143.600.20	250	42x2.0	45x2.0	28.0	17.5	20.0	50	30.0	278
◇ XGEV-42LM 48x2,0	706.1143.992.20	250	48x2.0	52x2.0	30.0	19.0	22.0	55	36.0	340

ISO 8434-1-SDS-B

D1=Rohr außen-Ø
M1=metrisches Anschlußgewinde
e=kleinster Innen-Ø
◇=entspricht Reihe nach DIN 2353

D1=tube outside diameter
M1=metric connecting thread
e=minimum inside diameter
◇=according to series DIN 2353

D1=Ø exterior del tubo
M1=rosca métrica conexión
e=Ø interior mínimo
◇=según serie DIN 2353

Gerade Einschraubverschraubungen

Abdichtung durch Dichtkante Form B nach DIN 3852-2

Straight male adaptor fittings

sealing edge form B acc. DIN 3852-2

Racores para roscar rectos

cierre hermético mediante borde de obturación forma B según DIN 3852-2

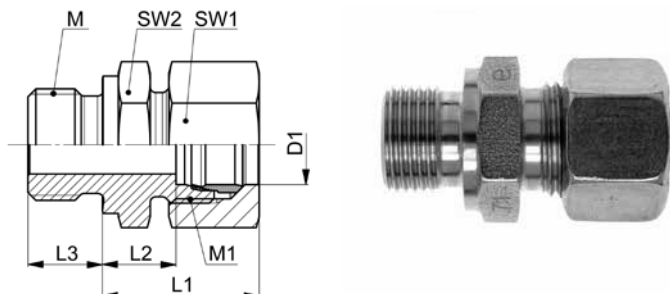

GEV-..LM

Type-D1 M	Mat.-Nr.	PN	M	M1	L1	L2	L3	SW1	SW2	g/Stk
M=metrisches Gewinde (zylindrisch)		M=metric thread (parallel)				M=rosca métrica (cilíndrica)				
◇ GEV-06LM 10x1,0	708.1143.180.20	500	10x1.0	12x1.5	23.5	8.5	8.0	14	14	27
GEV-06LM 12x1,5	708.1143.190.20	500	12x1.5	12x1.5	25.0	10.0	12.0	14	17	36
◇ GEV-08LM 12x1,5	708.1143.240.20	500	12x1.5	14x1.5	25.0	10.0	12.0	17	17	39
GEV-08LM 14x1,5	708.1143.245.20	500	14x1.5	14x1.5	25.0	10.0	12.0	17	19	45
GEV-08LM 18x1,5	708.1143.255.20	500	18x1.5	14x1.5	26.5	11.5	12.0	17	24	71
GEV-10LM 10x1,0	708.1143.270.20	500	10x1.0	16x1.5	25.5	10.5	8.0	19	17	44
GEV-10LM 12x1,5	708.1143.275.20	500	12x1.5	16x1.5	26.0	11.0	12.0	19	17	46
◇ GEV-10LM 14x1,5	708.1143.280.20	500	14x1.5	16x1.5	26.0	11.0	12.0	19	19	52
GEV-10LM 16x1,5	708.1143.285.20	500	16x1.5	16x1.5	27.5	12.5	12.0	19	22	66
GEV-10LM 18x1,5	708.1143.288.20	500	18x1.5	16x1.5	27.5	12.5	12.0	19	24	72
GEV-10LM 22x1,5	708.1143.290.20	500	22x1.5	16x1.5	30.0	14.0	14.0	19	27	86
GEV-12LM 14x1,5	708.1143.327.20	400	14x1.5	18x1.5	27.0	12.0	12.0	22	19	61
◇ GEV-12LM 16x1,5	708.1143.330.20	400	16x1.5	18x1.5	27.5	12.5	12.0	22	22	67
GEV-12LM 18x1,5	708.1143.333.20	400	18x1.5	18x1.5	27.5	12.5	12.0	22	24	77
GEV-12LM 22x1,5	708.1143.338.20	400	22x1.5	18x1.5	29.0	14.0	14.0	22	27	107
◇ GEV-15LM 18x1,5	708.1143.390.20	400	18x1.5	22x1.5	28.5	13.5	12.0	27	24	95
GEV-15LM 22x1,5	708.1143.395.20	400	22x1.5	22x1.5	30.0	15.0	14.0	27	27	121
GEV-18LM 18x1,5	708.1143.455.20	400	18x1.5	26x1.5	31.5	15.0	12.0	32	27	148
◇ GEV-18LM 22x1,5	708.1143.460.20	400	22x1.5	26x1.5	31.0	14.5	14.0	32	27	143
GEV-18LM 26x1,5	708.1143.465.20	400	26x1.5	26x1.5	31.0	14.5	16.0	32	32	155
GEV-22LM 18x1,5	708.1143.525.20	250	18x1.5	30x2.0	34.5	18.0	12.0	36	32	209
GEV-22LM 22x1,5	708.1143.530.20	250	22x1.5	30x2.0	35.0	18.5	14.0	36	32	202
◇ GEV-22LM 26x1,5	708.1143.535.20	250	26x1.5	30x2.0	33.0	16.5	16.0	36	32	191
◇ GEV-28LM 33x2,0	708.1143.570.20	250	33x2.0	36x2.0	34.0	17.5	18.0	41	41	267
◇ GEV-35LM 42x2,0	708.1143.600.20	250	42x2.0	45x2.0	39.0	17.5	20.0	50	50	437
◇ GEV-42LM 48x2,0	708.1143.992.20	250	48x2.0	52x2.0	42.0	19.0	22.0	60	55	581

Baumaße sind Ungefährmaße bei angezogener Überwurfmutter.

Sizes are approximate dimensions at tightened nut.

Las medidas son aproximadas con la tuerca de unión apretada.

ISO 8434-1-SDSC-B

D1=Rohr außen-Ø
M1=metrisches Anschlußgewinde
◇=entspricht Reihe nach DIN 2353

D1=tube outside diameter
M1=metric connecting thread
◇=according to series DIN 2353

D1=Ø exterior del tubo
M1=rosca métrica conexión
◇=según serie DIN 2353

Gerade Einschraubstutzen

Abdichtung durch Profildichtring Form E nach ISO 1179-2

Straight male adaptor connectors

profile sealing ring form E acc. ISO 1179-2

Cuerpos para roscar rectos

cierre hermético mediante junta con perfil forma E según ISO 1179-2

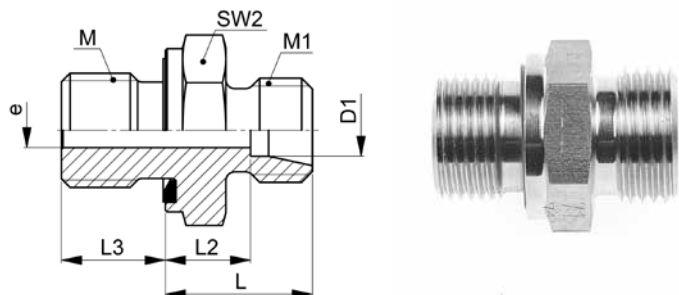

XGEV-..LM WD

Type-D1 M	Mat.-Nr.	PN	M	M1	L	L2	L3	SW2	e	g/Stk
M=metrisches Gewinde (zylindrisch)		M=metric thread (parallel)				M=rosca métrica (cilíndrica)				
◇ XGEV-06LM 10x1,0 WD	707.1173.180.20	500	10x1.0	12x1.5	15.5	8.5	8.0	14	4.0	15
XGEV-06LM 12x1,5 WD	707.1173.190.20	500	12x1.5	12x1.5	17.0	10.0	12.0	17	4.0	25
◇ XGEV-08LM 12x1,5 WD	707.1173.240.20	500	12x1.5	14x1.5	17.0	10.0	12.0	17	6.0	24
XGEV-08LM 14x1,5 WD	707.1173.245.20	500	14x1.5	14x1.5	17.0	10.0	12.0	19	6.0	31
XGEV-08LM 18x1,5 WD	707.1173.255.20	500	18x1.5	14x1.5	18.5	11.5	12.0	24	6.0	55
XGEV-10LM 10x1,0 WD	707.1173.270.20	500	10x1.0	16x1.5	17.5	10.5	8.0	17	4.0	24
XGEV-10LM 12x1,5 WD	707.1173.275.20	500	12x1.5	16x1.5	18.0	10.0	12.0	17	6.0	27
◇ XGEV-10LM 14x1,5 WD	707.1173.280.20	500	14x1.5	16x1.5	18.0	11.0	12.0	19	7.0	31
XGEV-10LM 16x1,5 WD	707.1173.285.20	500	16x1.5	16x1.5	19.5	12.5	12.0	22	7.0	46
XGEV-10LM 18x1,5 WD	707.1173.288.20	500	18x1.5	16x1.5	19.5	12.5	12.0	24	8.0	54
XGEV-10LM 22x1,5 WD	707.1173.290.20	500	22x1.5	16x1.5	21.0	14.0	14.0	27	8.0	86
XGEV-12LM 14x1,5 WD	707.1173.327.20	400	14x1.5	18x1.5	19.0	12.0	12.0	19	9.0	32
◇ XGEV-12LM 16x1,5 WD	707.1173.330.20	400	16x1.5	18x1.5	19.5	12.5	12.0	22	9.0	44
XGEV-12LM 18x1,5 WD	707.1173.333.20	400	18x1.5	18x1.5	20.0	13.0	12.0	24	9.0	55
XGEV-12LM 22x1,5 WD	707.1173.338.20	400	22x1.5	18x1.5	21.0	14.0	14.0	27	9.0	85
◇ XGEV-15LM 18x1,5 WD	707.1173.390.20	400	18x1.5	26x1.5	20.5	13.5	12.0	24	12.0	53
XGEV-15LM 22x1,5 WD	707.1173.395.20	400	22x1.5	22x1.5	22.0	15.0	14.0	27	12.0	83
XGEV-18LM 18x1,5 WD	707.1173.455.20	400	18x1.5	26x1.5	22.0	13.0	12.0	27	11.0	74
◇ XGEV-18LM 22x1,5 WD	707.1173.460.20	400	22x1.5	26x1.5	22.0	14.5	14.0	27	15.0	77
XGEV-18LM 26x1,5 WD	707.1173.465.20	400	26x1.5	26x1.5	22.0	14.5	16.0	32	15.0	118
XGEV-22LM 22x1,5 WD	707.1173.560.20	250	22x1.5	30x2.0	24.0	16.5	14.0	32	15.0	99
◇ XGEV-22LM 26x1,5 WD	707.1173.535.20	250	26x1.5	30x2.0	24.0	16.5	16.0	32	18.0	113
◇ XGEV-28LM 33x2,0 WD	707.1173.570.20	250	33x2.0	36x2.0	25.0	17.5	18.0	41	23.0	182
◇ XGEV-35LM 42x2,0 WD	707.1173.600.20	250	42x2.0	45x2.0	28.0	17.5	20.0	50	32.0	301
◇ XGEV-42LM 48x2,0 WD	707.1173.992.20	250	48x2.0	52x2.0	30.0	19.0	22.0	55	36.0	383

Dichtungsmaterial: FKM (andere Werkstoffe auf Anfrage)

Sealing material: FKM (other materials on request)

Material de junta tórica: FKM (otros materiales bajo demanda)

ISO 8434-1-SDS-E

D1=Rohr außen-Ø
M1=metrisches Anschlußgewinde
e=kleinster Innen-Ø
◇=entspricht Reihe nach DIN 2353

D1=tube outside diameter
M1=metric connecting thread
e=minimum inside diameter
◇=according to series DIN 2353

D1=Ø exterior del tubo
M1=rosca métrica conexión
e=Ø interior mínimo
◇=según serie DIN 2353

Gerade Einschraubverschraubungen

Abdichtung durch Profildichtring Form E nach ISO 1179-2

Straight male adaptor fittings

profile sealing ring form E acc. ISO 1179-2

Racores para roscar rectos

cierre hermético mediante junta con perfil forma E según ISO 1179-2

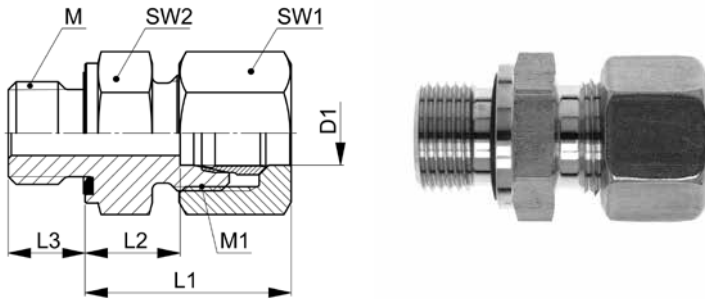

GEV-..LM WD

Type-D1 M	Mat.-Nr.	PN	M	M1	L1	L2	L3	SW1	SW2	g/Stk
M=metrisches Gewinde (zylindrisch)		M=metric thread (parallel)				M=rosca métrica (cilíndrica)				
◇ GEV-06LM 10x1,0 WD	708.1173.180.20	500	10x1.0	12x1.5	23.5	8.5	8.0	14	14	24
GEV-06LM 12x1,5 WD	708.1173.190.20	500	12x1.5	12x1.5	25.0	10.0	12.0	14	17	34
◇ GEV-08LM 12x1,5 WD	708.1173.240.20	500	12x1.5	14x1.5	25.0	10.0	12.0	17	17	37
GEV-08LM 14x1,5 WD	708.1173.245.20	500	14x1.5	14x1.5	25.0	10.0	12.0	17	19	45
GEV-08LM 18x1,5 WD	708.1173.255.20	500	18x1.5	14x1.5	26.5	11.5	12.0	17	24	79
GEV-10LM 10x1,0 WD	708.1173.270.20	500	10x1.0	16x1.5	25.5	10.5	8.0	19	17	66
GEV-10LM 12x1,5 WD	708.1173.275.20	500	12x1.5	16x1.5	26.0	11.0	12.0	19	17	46
◇ GEV-10LM 14x1,5 WD	708.1173.280.20	500	14x1.5	16x1.5	26.0	11.0	12.0	19	19	50
GEV-10LM 16x1,5 WD	708.1173.285.20	500	16x1.5	16x1.5	27.5	12.5	12.0	19	22	64
GEV-10LM 18x1,5 WD	708.1173.288.20	500	18x1.5	16x1.5	27.5	12.5	12.0	19	24	94
GEV-10LM 22x1,5 WD	708.1173.290.20	500	22x1.5	16x1.5	30.0	14.0	14.0	19	27	86
GEV-12LM 14x1,5 WD	708.1173.327.20	400	14x1.5	18x1.5	27.0	12.0	12.0	22	19	89
◇ GEV-12LM 16x1,5 WD	708.1173.330.20	400	16x1.5	18x1.5	27.5	12.5	12.0	22	22	67
GEV-12LM 18x1,5 WD	708.1173.333.20	400	18x1.5	18x1.5	28.0	13.0	12.0	22	24	79
GEV-12LM 22x1,5 WD	708.1173.338.20	400	22x1.5	18x1.5	29.0	14.0	14.0	22	27	117
◇ GEV-15LM 18x1,5 WD	708.1173.390.20	400	18x1.5	22x1.5	28.5	13.5	12.0	27	24	95
GEV-15LM 22x1,5 WD	708.1173.395.20	400	22x1.5	22x1.5	30.0	15.0	14.0	27	27	121
◇ GEV-18LM 22x1,5 WD	708.1173.460.20	400	22x1.5	26x1.5	31.0	14.5	14.0	32	27	141
GEV-18LM 26x1,5 WD	708.1173.465.20	400	26x1.5	26x1.5	31.0	14.5	16.0	32	32	169
GEV-22LM 22x1,5 WD	708.1173.560.20	250	22x1.5	30x2.0	35.0	16.5	14.0	36	32	196
◇ GEV-22LM 26x1,5 WD	708.1173.535.20	250	26x1.5	30x2.0	33.0	16.5	16.0	36	32	189
◇ GEV-28LM 33x2,0 WD	708.1173.570.20	250	33x2.0	36x2.0	34.0	17.5	18.0	41	41	267
◇ GEV-35LM 42x2,0 WD	708.1173.600.20	250	42x2.0	45x2.0	39.0	17.5	20.0	50	50	461
◇ GEV-42LM 48x2,0 WD	708.1173.992.20	250	48x2.0	52x2.0	42.5	19.0	22.0	60	55	599

Baumaße sind Ungefährmaße bei angezogener Überwurfmutter.

Sizes are approximate dimensions at tightened nut.

Las medidas son aproximadas con la tuerca de unión apretada.

Dichtungsmaterial: FKM (andere Werkstoffe auf Anfrage)

Sealing material: FKM (other materials on request)

Material de junta tórica: FKM (otros materiales bajo demanda)

ISO 8434-1-SDSC-E

D1=Rohr außen-Ø
M1=metrisches Anschlußgewinde
◇=entspricht Reihe nach DIN 2353

D1=tube outside diameter
M1=metric connecting thread
◇=according to series DIN 2353

D1=Ø exterior del tubo
M1=rosca métrica conexión
◇=según serie DIN 2353

Gerade Einschraubstutzen

Abdichtung durch Dichtkante Form B nach DIN 3852-2

Straight male adaptor connectors

sealing edge form B acc. DIN 3852-2

Cuerpos para roscar rectos

cierre hermético mediante borde de obturación forma B según DIN 3852-2

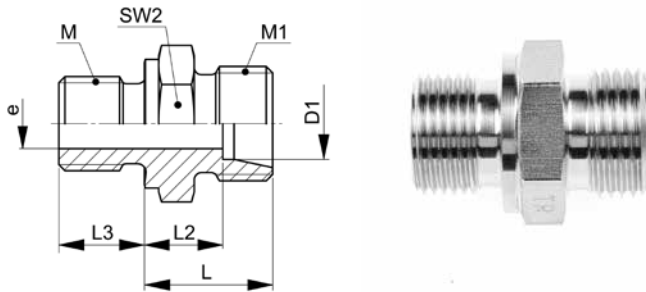

XGEV-..SM

Type-D1 M	Mat.-Nr.	PN	M	M1	L	L2	L3	SW2	e	g/Stk
M=metrisches Gewinde (zylindrisch)		M=metric thread (parallel)				M=rosca métrica (cilíndrica)				
◇ XGEV-06SM 12x1,5	706.1143.195.30	800	12x1.5	14x1.5	20.0	13.0	12.0	17	4.0	30
XGEV-06SM 14x1,5	706.1143.198.30	800	14x1.5	14x1.5	20.0	13.0	12.0	19	4.0	38
◇ XGEV-08SM 14x1,5	706.1143.245.30	800	14x1.5	16x1.5	22.0	15.0	12.0	19	5.0	42
◇ XGEV-10SM 16x1,5	706.1143.285.30	800	16x1.5	18x1.5	22.5	15.0	12.0	22	7.0	54
XGEV-12SM 14x1,5	706.1143.327.30	630	14x1.5	20x1.5	24.0	15.0	12.0	22	8.0	59
◇ XGEV-12SM 18x1,5	706.1143.333.30	630	18x1.5	20x1.5	24.5	17.0	12.0	24	8.0	72
XGEV-14SM 20x1,5	706.1143.382.30	630	20x1.5	22x1.5	27.0	19.0	14.0	27	10.0	90
◇ XGEV-16SM 22x1,5	706.1143.410.30	630	22x1.5	24x1.5	27.0	18.5	14.0	27	12.0	98
◇ XGEV-20SM 27x2,0	706.1143.506.30	420	27x2.0	30x2.0	31.0	20.5	16.0	32	16.0	165
◇ XGEV-25SM 33x2,0	706.1143.550.30	420	33x2.0	36x2.0	35.0	23.0	18.0	41	20.0	274
◇ XGEV-30SM 42x2,0	706.1143.590.30	420	42x2.0	42x2.0	37.0	23.5	20.0	50	25.0	434
◇ XGEV-38SM 48x2,0	706.1143.954.30	420	48x2.0	52x2.0	42.0	26.0	22.0	55	32.0	580

ISO 8434-1-SDS-B

D1=Rohr außen-Ø
 M1=metrisches Anschlußgewinde
 e=kleinster Innen-Ø
 ◇=entspricht Reihe nach DIN 2353

D1=tube outside diameter
 M1=metric connecting thread
 e=minimum inside diameter
 ◇=according to series DIN 2353

D1=Ø exterior del tubo
 M1=rosca métrica conexión
 e=Ø interior mínimo
 ◇=según serie DIN 2353

Gerade Einschraubverschraubungen

Abdichtung durch Dichtkante Form B nach DIN 3852-2

Straight male adaptor fittings

sealing edge form B acc. DIN 3852-2

Racores para roscar rectos

cierre hermético mediante borde de obturación forma B según DIN 3852-2

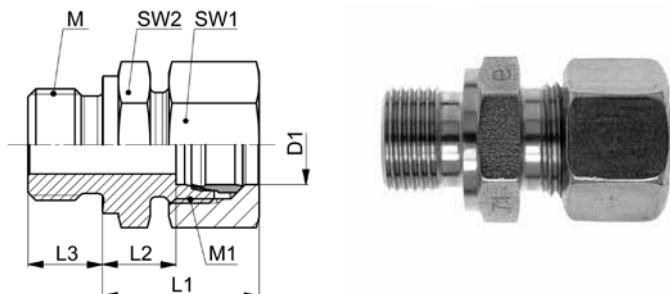

GEV-..SM

Type-D1 M	Mat.-Nr.	PN	M	M1	L1	L2	L3	SW1	SW2	g/Stk
M=metrisches Gewinde (zylindrisch)		M=metric thread (parallel)				M=rosca métrica (cilíndrica)				
◇ GEV-06SM 12x1,5	708.1143.195.30	800	12x1.5	14x1.5	28.0	13.0	12.0	17	17	48
GEV-06SM 14x1,5	708.1143.198.30	800	14x1.5	14x1.5	30.0	13.0	12.0	17	19	56
◇ GEV-08SM 14x1,5	708.1143.245.30	800	14x1.5	16x1.5	30.0	15.0	12.0	19	19	64
◇ GEV-10SM 16x1,5	708.1143.285.30	800	16x1.5	18x1.5	31.5	15.0	12.0	22	22	88
GEV-12SM 14x1,5	708.1143.327.30	630	14x1.5	20x1.5	33.0	15.0	12.0	24	22	96
◇ GEV-12SM 18x1,5	708.1143.333.30	630	18x1.5	20x1.5	33.5	17.0	12.0	24	24	110
GEV-14SM 20x1,5	708.1143.382.30	630	20x1.5	22x1.5	37.0	19.0	14.0	27	27	150
◇ GEV-16SM 22x1,5	708.1143.410.30	630	22x1.5	24x1.5	37.0	18.5	14.0	30	27	165
◇ GEV-20SM 27x2,0	708.1143.506.30	420	27x2.0	30x2.0	42.0	20.5	16.0	36	32	265
◇ GEV-25SM 33x2,0	708.1143.550.30	420	33x2.0	36x2.0	47.0	23.0	18.0	46	41	490
◇ GEV-30SM 42x2,0	708.1143.590.30	420	42x2.0	42x2.0	50.0	23.5	20.0	50	50	690
◇ GEV-38SM 48x2,0	708.1143.954.30	420	48x2.0	52x2.0	57.0	26.0	22.0	60	55	940

Baumaße sind Ungefährmaße bei angezogener Überwurfmutter.

Sizes are approximate dimensions at tightened nut.

Las medidas son aproximadas con la tuerca de unión apretada.

ISO 8434-1-SDSC-B

D1=Rohr außen-Ø
M1=metrisches Anschlußgewinde
◇=entspricht Reihe nach DIN 2353

D1=tube outside diameter
M1=metric connecting thread
◇=according to series DIN 2353

D1=Ø exterior del tubo
M1=rosca métrica conexión
◇=según serie DIN 2353

Gerade Einschraubstutzen

Abdichtung durch Profildichtring Form E nach ISO 1179-2

Straight male adaptor connectors

profile sealing ring form E acc. ISO 1179-2

Cuerpos para roscar rectos

cierre hermético mediante junta con perfil forma E según ISO 1179-2

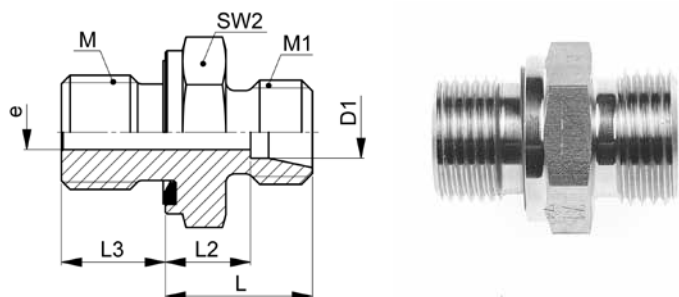

XGEV-..SM WD

Type-D1 M	Mat.-Nr.	PN	M	M1	L	L2	L3	SW2	e	g/Stk
M=metrisches Gewinde (zylindrisch)		M=metric thread (parallel)				M=rosca métrica (cilíndrica)				
◇ XGEV-06SM 12x1,5 WD	707.1173.195.30	800	12x1.5	14x1.5	20.0	13.0	12.0	17	4.0	30
XGEV-06SM 14x1,5 WD	707.1173.198.30	800	14x1.5	14x1.5	22.0	15.0	12.0	19	4.0	42
◇ XGEV-08SM 14x1,5 WD	707.1173.245.30	800	14x1.5	16x1.5	22.0	15.0	12.0	19	5.0	42
◇ XGEV-10SM 16x1,5 WD	707.1173.285.30	800	16x1.5	18x1.5	22.5	15.0	12.0	22	7.0	54
XGEV-12SM 14x1,5 WD	707.1173.327.30	630	14x1.5	20x1.5	24.0	16.5	12.0	22	8.0	52
◇ XGEV-12SM 18x1,5 WD	707.1173.333.30	630	18x1.5	20x1.5	24.5	17.0	12.0	24	8.0	72
XGEV-14SM 20x1,5 WD	707.1173.382.30	630	20x1.5	22x1.5	27.0	19.0	14.0	27	10.0	94
◇ XGEV-16SM 22x1,5 WD	707.1173.410.30	630	22x1.5	24x1.5	27.0	18.5	14.0	27	12.0	98
◇ XGEV-20SM 27x2,0 WD	707.1173.506.30	420	27x2.0	30x2.0	31.0	20.5	16.0	32	16.0	152
◇ XGEV-25SM 33x2,0 WD	707.1173.550.30	420	33x2.0	36x2.0	35.0	23.0	18.0	41	20.0	270
◇ XGEV-30SM 42x2,0 WD	707.1173.590.30	420	42x2.0	42x2.0	37.0	23.5	20.0	50	25.0	436
◇ XGEV-38SM 48x2,0 WD	707.1173.954.30	420	48x2.0	52x2.0	42.0	26.0	22.0	55	32.0	580

Dichtungsmaterial: FKM (andere Werkstoffe auf Anfrage)

Sealing material: FKM (other materials on request)

Material de junta tórica: FKM (otros materiales bajo demanda)

ISO 8434-1-SDS-E

D1=Rohr außen-Ø
 M1=metrisches Anschlußgewinde
 e=kleinster Innen-Ø
 ◇=entspricht Reihe nach DIN 2353

D1=tube outside diameter
 M1=metric connecting thread
 e=minimum inside diameter
 ◇=according to series DIN 2353

D1=Ø exterior del tubo
 M1=rosca métrica conexión
 e=Ø interior mínimo
 ◇=según serie DIN 2353

Gerade Einschraubverschraubungen

Abdichtung durch Profildichtring Form E nach ISO 1179-2

Straight male adaptor fittings

profile sealing ring form E acc. ISO 1179-2

Racores para roscar rectos

cierre hermético mediante junta con perfil forma E según ISO 1179-2

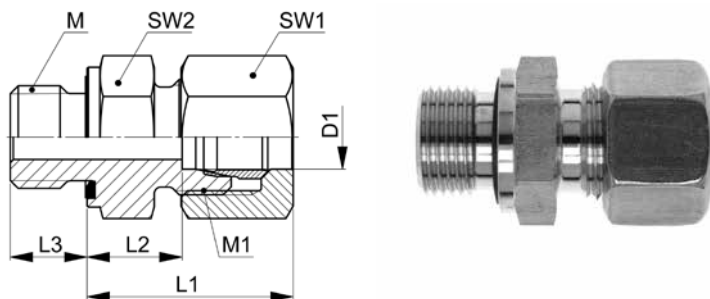

GEV-..SM WD

Type-D1 M	Mat.-Nr.	PN	M	M1	L1	L2	L3	SW1	SW2	g/Stk
M=metrisches Gewinde (zylindrisch)		M=metric thread (parallel)				M=rosca métrica (cilíndrica)				
◇ GEV-06SM 12x1,5 WD	708.1173.195.30	800	12x1.5	14x1.5	28.0	13.0	12.0	17	17	48
GEV-06SM 14x1,5 WD	708.1173.198.30	800	14x1.5	14x1.5	30.0	15.0	12.0	17	19	58
◇ GEV-08SM 14x1,5 WD	708.1173.245.30	800	14x1.5	16x1.5	30.0	15.0	12.0	19	19	62
◇ GEV-10SM 16x1,5 WD	708.1173.285.30	800	16x1.5	18x1.5	31.5	15.0	12.0	22	22	88
GEV-12SM 14x1,5 WD	708.1173.327.30	630	14x1.5	20x1.5	33.0	16.5	12.0	24	22	90
◇ GEV-12SM 18x1,5 WD	708.1173.333.30	630	18x1.5	20x1.5	33.5	17.0	12.0	24	24	110
GEV-14SM 20x1,5 WD	708.1173.382.30	630	20x1.5	22x1.5	37.0	19.0	14.0	27	27	150
◇ GEV-16SM 22x1,5 WD	708.1173.410.30	630	22x1.5	24x1.5	37.0	18.5	14.0	30	27	165
◇ GEV-20SM 27x2,0 WD	708.1173.506.30	420	27x2.0	30x2.0	42.0	20.5	16.0	36	32	265
◇ GEV-25SM 33x2,0 WD	708.1173.550.30	420	33x2.0	36x2.0	47.0	23.0	18.0	46	41	490
◇ GEV-30SM 42x2,0 WD	708.1173.590.30	420	42x2.0	42x2.0	50.0	23.5	20.0	50	50	690
◇ GEV-38SM 48x2,0 WD	708.1173.954.30	420	48x2.0	52x2.0	57.0	26.0	22.0	60	55	940

Baumaße sind Ungefährmaße bei angezogener Überwurfmutter.

Sizes are approximate dimensions at tightened nut.

Las medidas son aproximadas con la tuerca de unión apretada.

Dichtungsmaterial: FKM (andere Werkstoffe auf Anfrage)

Sealing material: FKM (other materials on request)

Material de junta tórica: FKM (otros materiales bajo demanda)

ISO 8434-1-SDSC-E

D1=Rohr außen-Ø
M1=metrisches Anschlußgewinde
◇=entspricht Reihe nach DIN 2353

D1=tube outside diameter
M1=metric connecting thread
◇=according to series DIN 2353

D1=Ø exterior del tubo
M1=rosca métrica conexión
◇=según serie DIN 2353

Gerade Einschraubstutzen

Abdichtung im Kegeltengewinde Form C nach DIN 3852-2

Straight male adaptor connectors

taper thread sealing form C acc. DIN 3852-2

Cuerpos para roscar rectos

cierre hermético con rosca cónica forma C según DIN 3852-2

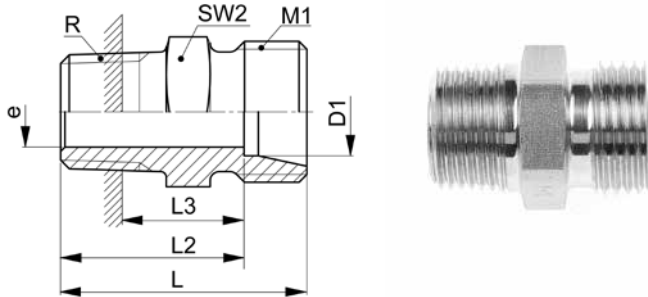

XGEV-..LRK

Type-D1 R	Mat.-Nr.	PN	R	M1	L	L2	L3	SW2	e	g/Stk
R=Rohrgewinde (kegelig)		R=BSP thread (tapered)						R=rosca para tubos (cónica)		
◇ XGEV-04LLRK 1.8	706.1101.060.10	100	1/8	8x1.0	20.0	16.0	11.0	11	3.0	9
◇ XGEV-06LLRK 1.8	706.1101.100.10	100	1/8	10x1.0	20.0	14.5	9.5	11	4.0	9
◇ XGEV-08LLRK 1.8	706.1101.160.10	100	1/8	12x1.0	22.0	16.5	11.5	12	6.0	11
XGEV-08LLRK 1.4	706.1101.170.10	100	1/4	12x1.0	26.0	20.5	12.5	14	6.0	20
◇ XGEV-06LRK 1.8	706.1101.100.20	315	1/8	12x1.5	23.0	16.0	11.0	12	4.0	14
XGEV-06LRK 1.4	706.1101.110.20	315	1/4	12x1.5	27.0	19.0	11.0	14	4.0	23
XGEV-06LRK 3.8	706.1101.120.20	315	3/8	12x1.5	26.0	19.0	11.0	17	4.0	32
XGEV-06LRK 1.2	706.1101.125.20	315	1/2	12x1.5	29.0	22.0	12.0	22	4.0	54
XGEV-08LRK 1.8	706.1101.160.20	315	1/8	14x1.5	23.0	16.0	11.0	14	6.0	17
◇ XGEV-08LRK 1.4	706.1101.170.20	315	1/4	14x1.5	27.0	20.0	12.0	17	6.0	25
XGEV-08LRK 3.8	706.1101.180.20	315	3/8	14x1.5	27.0	20.0	12.0	17	6.0	33
XGEV-08LRK 1.2	706.1101.185.20	315	1/2	14x1.5	29.0	22.0	12.0	22	6.0	50
XGEV-10LRK 1.8	706.1101.265.20	315	1/8	16x1.5	24.0	17.0	12.0	17	6.0	23
◇ XGEV-10LRK 1.4	706.1101.270.20	315	1/4	16x1.5	28.0	21.0	13.0	17	8.0	27
XGEV-10LRK 3.8	706.1101.280.20	315	3/8	16x1.5	28.0	21.0	13.0	17	8.0	32
XGEV-10LRK 1.2	706.1101.285.20	315	1/2	16x1.5	30.0	23.0	13.0	22	8.0	50
XGEV-12LRK 1.4	706.1101.380.20	315	1/4	18x1.5	29.0	22.0	14.0	19	8.0	34
◇ XGEV-12LRK 3.8	706.1101.390.20	315	3/8	18x1.5	29.0	22.0	14.0	19	9.0	37
XGEV-12LRK 1.2	706.1101.400.20	315	1/2	18x1.5	31.0	24.0	14.0	22	9.0	54
XGEV-15LRK 3.8	706.1101.532.20	315	3/8	22x1.5	30.0	23.0	15.0	24	9.0	55
◇ XGEV-15LRK 1.2	706.1101.534.20	315	1/2	22x1.5	32.0	25.0	15.0	24	12.0	56
◇ XGEV-18LRK 1.2	706.1101.646.20	315	1/2	26x1.5	33.0	25.5	15.5	27	12.0	75
XGEV-18LRK 3.4	706.1101.648.20	315	3/4	26x1.5	35.0	27.5	15.5	27	15.0	90
XGEV-22LRK 1.2	706.1101.764.20	160	1/2	30x2.0	35.0	27.5	17.5	32	12.0	106
XGEV-22LRK 3.4	706.1101.768.20	160	3/4	30x2.0	37.0	29.5	17.5	32	19.0	95
XGEV-28LRK 1.1	706.1101.850.20	160	1	36x2.0	40.0	32.5	18.5	41	24.0	160
XGEV-35LRK 1.1	706.1101.925.20	160	1	45x2.0	43.0	32.5	18.5	46	24.0	235
XGEV-42LRK 3.2	706.1101.992.20	160	1 1/2	52x2.0	49.0	38.0	24.0	55	36.0	361

Druckangaben gelten in Verbindung mit zylindrischem Innengewinde.

Pressure information applies in connection with parallel female thread.

Datos de presión válidos en combinación con roscas interiores cilíndricas.

Einbaumaß L3 ist abhängig von den Masstoleranzen des Gegenstückes.

Installation size L3 is dependent on the size tolerances of the counterpart.

Distancia de referencia L3 según las tolerancias dimensionales de la contrapieza.

D1=Rohr außen-Ø
M1=metrisches Anschlußgewinde
e=kleinster Innen-Ø
◇=entspricht Reihe nach DIN 2353

D1=tube outside diameter
M1=metric connecting thread
e=minimum inside diameter
◇=according to series DIN 2353

D1=Ø exterior del tubo
M1=rosca métrica conexión
e=Ø interior mínimo
◇=según serie DIN 2353

Gerade Einschraubverschraubungen

Abdichtung durch Kegelfwinde Form C nach DIN 3852-2

Straight male adaptor fittings

taper thread sealing form C acc. DIN 3852-2

Racores para roscar rectos

cierre hermético con rosca cónica forma C según DIN 3852-2

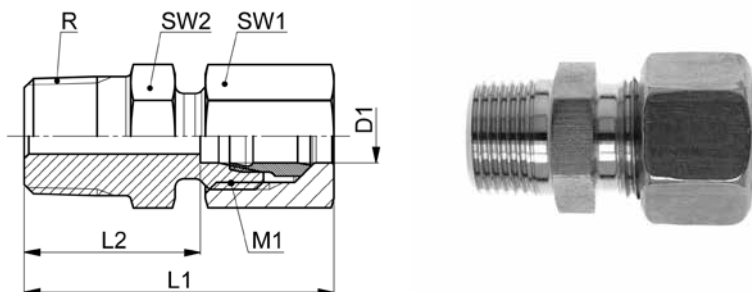

GEV-..LRK

Type-D1 R	Mat.-Nr.	PN	R	M1	L1	L2	SW1	SW2	g/Stk
R=Rohrgewinde (kegelig)		R=BSP thread (tapered)				R=rosca para tubos (cónica)			
◇ GEV-04LLRK 1.8	708.1101.060.10	100	1/8	8x1.0	26.0	16.0	10	11	11
◇ GEV-06LLRK 1.8	708.1101.100.10	100	1/8	10x1.0	26.0	14.5	12	11	15
◇ GEV-08LLRK 1.8	708.1101.160.10	100	1/8	12x1.0	28.5	16.5	14	12	18
GEV-08LLRK 1.4	708.1101.170.10	100	1/4	12x1.0	32.5	20.5	14	14	26
◇ GEV-06LRK 1.8	708.1101.100.20	315	1/8	12x1.5	31.0	16.0	14	12	27
GEV-06LRK 1.4	708.1101.110.20	315	1/4	12x1.5	35.0	19.0	14	14	28
GEV-06LRK 3.8	708.1101.120.20	315	3/8	12x1.5	34.0	19.0	14	17	34
GEV-06LRK 1.2	708.1101.125.20	315	1/2	12x1.5	37.0	22.0	14	22	60
GEV-08LRK 1.8	708.1101.160.20	315	1/8	14x1.5	31.0	16.0	17	14	32
◇ GEV-08LRK 1.4	708.1101.170.20	315	1/4	14x1.5	35.0	20.0	17	17	40
GEV-08LRK 3.8	708.1101.180.20	315	3/8	14x1.5	35.0	20.0	17	17	46
GEV-08LRK 1.2	708.1101.185.20	315	1/2	14x1.5	37.0	22.0	17	22	60
GEV-10LRK 1.8	708.1101.265.20	315	1/8	16x1.5	32.5	17.0	19	17	38
◇ GEV-10LRK 1.4	708.1101.270.20	315	1/4	16x1.5	36.5	21.0	19	17	44
GEV-10LRK 3.8	708.1101.280.20	315	3/8	16x1.5	36.5	21.0	19	17	57
GEV-10LRK 1.2	708.1101.285.20	315	1/2	16x1.5	38.5	23.0	19	22	70
GEV-12LRK 1.4	708.1101.380.20	315	1/4	18x1.5	37.5	22.0	22	19	58
◇ GEV-12LRK 3.8	708.1101.390.20	315	3/8	18x1.5	37.5	22.0	22	19	62
GEV-12LRK 1.2	708.1101.400.20	315	1/2	18x1.5	39.5	24.0	22	22	80
GEV-15LRK 3.8	708.1101.532.20	315	3/8	22x1.5	39.0	23.0	27	24	94
◇ GEV-15LRK 1.2	708.1101.534.20	315	1/2	22x1.5	41.0	25.0	27	24	105
◇ GEV-18LRK 1.2	708.1101.646.20	160	1/2	26x1.5	42.5	25.5	32	27	145
GEV-18LRK 3.4	708.1101.648.20	315	3/4	26x1.5	44.5	27.5	32	27	162
GEV-22LRK 1.2	708.1101.764.20	160	1/2	30x2.0	44.5	27.5	36	32	188
GEV-22LRK 3.4	708.1101.768.20	160	3/4	30x2.0	46.0	29.5	36	32	192
GEV-28LRK 1.1	708.1101.850.20	160	1	36x2.0	49.5	32.5	41	41	272
GEV-35LRK 1.1	708.1101.925.20	160	1	45x2.0	55.0	32.5	50	46	420
GEV-42LRK 3.2	708.1101.992.20	160	1 1/2	52x2.0	61.5	38.0	60	55	594

Druckangaben gelten in Verbindung mit zylindrischem Innengewinde.

Pressure information applies in connection with parallel female thread.

Datos de presión válidos en combinación con roscas interiores cilíndricas.

Baumaße sind Ungefährmaße bei angezogener Überwurfmutter.

Sizes are approximate dimensions at tightened nut.

Las medidas son aproximadas con la tuerca de unión apretada.

D1=Rohr außen-Ø
M1=metrisches Anschlußgewinde
◇=entspricht Reihe nach DIN 2353

D1=tube outside diameter
M1=metric connecting thread
◇=according to series DIN 2353

D1=Ø exterior del tubo
M1=rosca métrica conexión
◇=según serie DIN 2353

Gerade Einschraubstutzen

Abdichtung im Kegengewinde Form C nach DIN 3852-2

Straight male adaptor connectors

taper thread sealing form C acc. DIN 3852-2

Cuerpos para roscar rectos

cierre hermético con rosca cónica forma C según DIN 3852-2

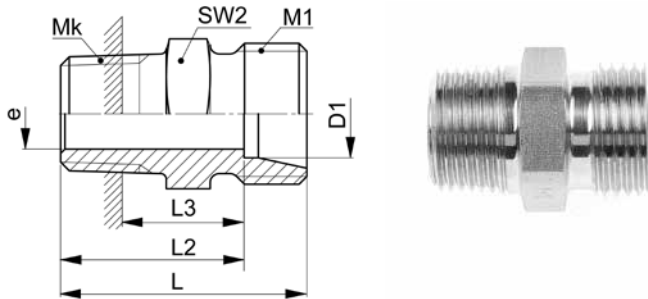

XGEV-..LMK

Type-D1 Mk	Mat.-Nr.	PN	Mk	M1	L	L2	L3	SW2	e	g/Stk
Mk=metrisches Gewinde (kegelig)		Mk=metric thread (tapered)			Mk=rosca métrica (cónica)					
◇ XGEV-04LLMK 08x1,0	706.1103.090.10	100	08x1.0	8x1.0	20.0	16.0	10.5	10	3.0	6
XGEV-06LLMK 08x1,0	706.1103.170.10	100	08x1.0	10x1.0	20.0	14.5	9.0	11	4.0	8
◇ XGEV-06LLMK 10x1,0	706.1103.180.10	100	10x1.0	10x1.0	20.0	14.5	9.0	11	4.0	8
◇ XGEV-08LLMK 10x1,0	706.1103.230.10	100	10x1.0	12x1.0	22.0	16.5	11.0	12	6.0	10
XGEV-06LMK 08x1,0	706.1103.170.20	315	08x1.0	12x1.5	23.0	16.0	10.5	12	4.0	10
◇ XGEV-06LMK 10x1,0	706.1103.180.20	315	10x1.0	12x1.5	23.0	16.0	10.5	14	4.0	14
XGEV-06LMK 12x1,5	706.1103.195.20	315	12x1.5	12x1.5	27.0	20.0	11.5	14	4.0	20
◇ XGEV-08LMK 12x1,5	706.1103.240.20	315	12x1.5	14x1.5	27.0	20.0	11.5	14	6.0	20
XGEV-08LMK 14x1,5	706.1103.245.20	315	14x1.5	14x1.5	27.0	20.0	11.5	17	6.0	22
◇ XGEV-10LMK 14x1,5	706.1103.280.20	315	14x1.5	16x1.5	28.0	21.0	12.5	17	7.0	24
XGEV-10LMK 16x1,5	706.1103.285.20	315	16x1.5	16x1.5	28.0	21.0	12.5	17	8.0	28
◇ XGEV-12LMK 16x1,5	706.1103.330.20	315	16x1.5	18x1.5	29.0	22.0	13.1	19	9.0	32
XGEV-12LMK 18x1,5	706.1103.333.20	315	18x1.5	18x1.5	29.0	22.0	13.1	19	9.0	50
◇ XGEV-15LMK 18x1,5	706.1103.390.20	315	18x1.5	26x1.5	30.0	23.0	14.5	24	11.0	46
◇ XGEV-18LMK 22x1,5	706.1103.460.20	315	22x1.5	26x1.5	33.0	25.5	17.0	27	14.0	89

Druckangaben gelten in Verbindung mit zylindrischem Innengewinde.

Pressure information applies in connection with parallel female thread.

Datos de presión válidos en combinación con roscas interiores cilíndricas.

Einbaumaß L3 ist abhängig von den Masstoleranzen des Gegenstückes.

Installation size L3 is dependent on the size tolerances of the counterpart.

Distancia de referencia L3 según las tolerancias dimensionales de la contrapieza.

D1=Rohr außen-Ø
M1=metrisches Anschlußgewinde
e=kleinster Innen-Ø
◇=entspricht Reihe nach DIN 2353

D1=tube outside diameter
M1=metric connecting thread
e=minimum inside diameter
◇=according to series DIN 2353

D1=Ø exterior del tubo
M1=rosca métrica conexión
e=Ø interior mínimo
◇=según serie DIN 2353

Gerade Einschraubverschraubungen

Abdichtung durch Kegeln Gewinde Form C nach DIN 3852-2

Straight male adaptor fittings

taper thread sealing form C acc. DIN 3852-2

Racores para roscar rectos

cierre hermético con rosca cónica forma C según DIN 3852-2

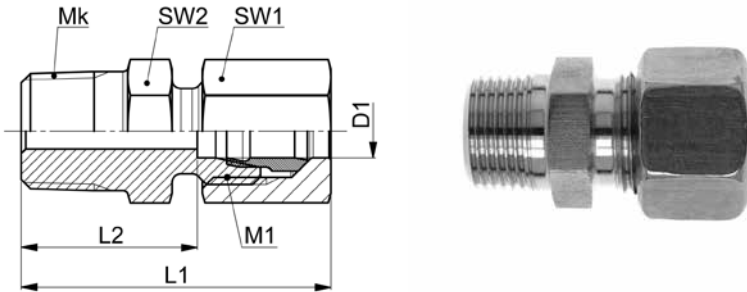

GEV-..LMK

Type-D1 Mk	Mat.-Nr.	PN	Mk	M1	L1	L2	SW1	SW2	g/Stk
Mk=metrisches Gewinde (kegelig)	Mk=metric thread (tapered)					Mk=rosca métrica (cónica)			
◇ GEV-04LLMK 08x1,0	708.1103.090.10	100	08x1.0	8x1.0	26.0	16.0	10	10	11
GEV-06LLMK 08x1,0	708.1103.170.10	100	08x1.0	10x1.0	26.0	14.5	12	11	15
◇ GEV-06LLMK 10x1,0	708.1103.180.10	100	10x1.0	10x1.0	26.0	14.5	12	11	15
◇ GEV-08LLMK 10x1,0	708.1103.230.10	100	10x1.0	12x1.0	28.0	16.5	14	12	18
GEV-06LMK 08x1,0	708.1103.170.20	315	08x1.0	12x1.5	31.0	16.0	14	12	22
◇ GEV-06LMK 10x1,0	708.1103.180.20	315	10x1.0	12x1.5	31.0	16.0	14	14	26
GEV-06LMK 12x1,5	708.1103.195.20	315	12x1.5	12x1.5	35.0	20.0	14	14	32
◇ GEV-08LMK 12x1,5	708.1103.240.20	315	12x1.5	14x1.5	35.0	20.0	17	14	35
GEV-08LMK 14x1,5	708.1103.245.20	315	14x1.5	14x1.5	35.0	20.0	17	17	39
◇ GEV-10LMK 14x1,5	708.1103.280.20	315	14x1.5	16x1.5	36.0	21.0	19	17	46
GEV-10LMK 16x1,5	708.1103.285.20	315	16x1.5	16x1.5	36.0	21.0	19	17	50
◇ GEV-12LMK 16x1,5	708.1103.330.20	315	16x1.5	18x1.5	37.0	22.0	22	19	59
GEV-12LMK 18x1,5	708.1103.333.20	315	18x1.5	18x1.5	37.0	22.0	22	19	77
◇ GEV-15LMK 18x1,5	708.1103.390.20	315	18x1.5	26x1.5	38.0	23.0	27	24	91
◇ GEV-18LMK 22x1,5	708.1103.460.20	315	22x1.5	26x1.5	42.0	25.5	32	27	156

Druckangaben gelten in Verbindung mit zylindrischem Innengewinde.

Pressure information applies in connection with parallel female thread.

Datos de presión válidos en combinación con roscas interiores cilíndricas.

Baumaße sind Ungefährmaße bei angezogener Überwurfmutter.

Sizes are approximate dimensions at tightened nut.

Las medidas son aproximadas con la tuerca de unión apretada.

D1=Rohr außen-Ø
M1=metrisches Anschlußgewinde
◇=entspricht Reihe nach DIN 2353

D1=tube outside diameter
M1=metric connecting thread
◇=according to series DIN 2353

D1=Ø exterior del tubo
M1=rosca métrica conexión
◇=según serie DIN 2353

Gerade Einschraubstutzen NPT
Straight male adaptor connectors NPT
Cuerpos para roscar NPT rectos

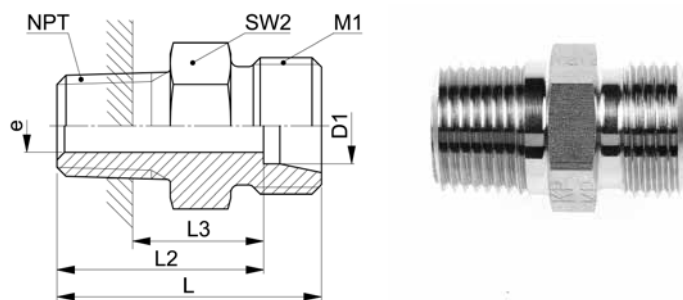

XGEV-..LNPT

Type-D1 NPT	Mat.-Nr.	PN	NPT	M1	L	L2	L3	SW2	e	g/Stk
NPT=Einschraubgewinde NPT		NPT=tapered male adaptor thread NPT			NPT=rosca de conexión cónica NPT					
XGEV-04LLNPT 1.8	706.1102.060.10	100	1/8	8x1.0	22.0	18.0	11.0	11	3.0	8
XGEV-06LLNPT 1.8	706.1102.100.10	100	1/8	10x1.0	22.0	16.5	9.5	11	4.5	8
XGEV-08LLNPT 1.8	706.1102.160.10	100	1/8	12x1.0	24.0	18.5	11.5	12	6.0	8
XGEV-06LNPT 1.8	706.1102.100.20	500	1/8	12x1.5	24.0	17.0	10.0	12	4.0	12
XGEV-06LNPT 1.4	706.1102.110.20	500	1/4	12x1.5	30.0	23.0	13.0	17	4.0	26
XGEV-06LNPT 3.8	706.1102.120.20	500	3/8	12x1.5	31.0	24.0	14.0	19	4.0	40
XGEV-06LNPT 1.2	706.1102.125.20	500	1/2	12x1.5	36.0	29.0	15.0	22	4.0	70
XGEV-08LNPT 1.8	706.1102.160.20	500	1/8	14x1.5	25.0	18.0	11.0	14	4.5	14
XGEV-08LNPT 1.4	706.1102.170.20	500	1/4	14x1.5	30.0	23.0	13.0	17	6.0	26
XGEV-08LNPT 3.8	706.1102.180.20	500	3/8	14x1.5	31.0	24.0	14.0	19	6.0	38
XGEV-08LNPT 1.2	706.1102.185.20	500	1/2	14x1.5	36.0	29.0	15.0	22	6.0	68
XGEV-10LNPT 1.8	706.1102.265.20	500	1/8	16x1.5	26.0	19.0	12.0	17	4.5	20
XGEV-10LNPT 1.4	706.1102.270.20	500	1/4	16x1.5	31.0	24.0	14.0	17	7.0	26
XGEV-10LNPT 3.8	706.1102.280.20	500	3/8	16x1.5	32.0	25.0	15.0	19	8.0	38
XGEV-10LNPT 1.2	706.1102.285.20	500	1/2	16x1.5	37.0	30.0	16.0	22	8.0	66
XGEV-10LNPT 3.4	706.1102.290.20	500	3/4	16x1.5	38.0	31.0	17.0	27	8.0	93
XGEV-12LNPT 1.8	706.1102.375.20	400	1/8	18x1.5	27.0	20.0	13.0	19	4.5	28
XGEV-12LNPT 1.4	706.1102.380.20	400	1/4	18x1.5	32.0	25.0	15.0	19	7.0	32
XGEV-12LNPT 3.8	706.1102.390.20	400	3/8	18x1.5	32.0	25.0	15.0	19	9.0	37
XGEV-12LNPT 1.2	706.1102.400.20	400	1/2	18x1.5	37.0	30.0	16.0	22	10.0	70
XGEV-12LNPT 3.4	706.1102.405.20	400	3/4	18x1.5	38.0	31.0	17.0	27	10.0	106
XGEV-15LNPT 1.4	706.1102.528.20	400	1/4	22x1.5	33.0	26.0	16.0	24	7.0	46
XGEV-15LNPT 3.8	706.1102.532.20	400	3/8	22x1.5	33.0	26.0	16.0	24	10.0	52
XGEV-15LNPT 1.2	706.1102.534.20	400	1/2	22x1.5	38.0	31.0	17.0	24	12.0	66
XGEV-15LNPT 3.4	706.1102.536.20	400	3/4	22x1.5	39.0	32.0	18.0	27	12.0	106
XGEV-15LNPT 1.1	706.1102.541.20	400	1	22x1.5	45.0	38.0	20.0	36	12.0	158
XGEV-18LNPT 3.8	706.1102.644.20	400	3/8	26x1.5	34.0	26.5	16.5	27	10.0	70
XGEV-18LNPT 1.2	706.1102.646.20	400	1/2	26x1.5	39.0	31.5	17.5	27	14.0	72
XGEV-18LNPT 3.4	706.1102.648.20	400	3/4	26x1.5	39.0	31.5	17.5	27	14.0	102
XGEV-18LNPT 1.1	706.1102.652.20	400	1	26x1.5	45.0	37.5	19.5	36	15.0	194
XGEV-22LNPT 3.8	706.1102.763.20	250	3/8	30x2.0	36.0	28.5	18.5	32	10.0	96
XGEV-22LNPT 1.2	706.1102.764.20	250	1/2	30x2.0	41.0	33.5	19.5	32	14.0	106
XGEV-22LNPT 3.4	706.1102.768.20	250	3/4	30x2.0	41.0	33.5	19.5	32	18.0	104
XGEV-22LNPT 1.1	706.1102.770.20	250	1	30x2.0	47.0	39.5	21.5	36	18.0	194

Fortsetzung auf nächster linker Seite

To be continued on next left page

Continuación próxima página izquierda

D1=Rohr außen-Ø
M1=metrisches Anschlußgewinde
e=kleinster Innen-Ø

D1=tube outside diameter
M1=metric connecting thread
e=minimum inside diameter

D1=Ø exterior del tubo
M1=rosca métrica conexión
e=Ø interior mínimo

Gerade Einschraubverschraubungen NPT
Straight male adaptor fittings NPT
Racores para roscar rectos NPT

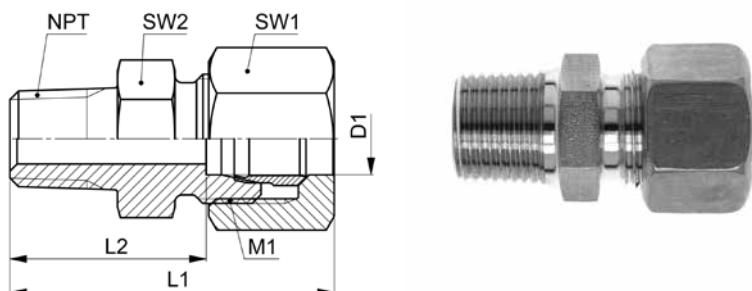

10

GEV-..LNPT

Type-D1 NPT	Mat.-Nr.	PN	NPT	M1	L1	L2	SW1	SW2	g/Stk
NPT=Einschraubgewinde NPT NPT=tapered male adaptor thread NPT NPT=rosca de conexión cónica NPT									
GEV-04LLNPT 1.8	708.1102.060.10	100	1/8	8x1.0	28.0	18.0	10	11	14
GEV-06LLNPT 1.8	708.1102.100.10	100	1/8	10x1.0	28.0	16.5	12	11	16
GEV-08LLNPT 1.8	708.1102.160.10	100	1/8	12x1.0	30.0	18.5	14	12	19
GEV-06LNPT 1.8	708.1102.100.20	500	1/8	12x1.5	32.0	17.0	14	12	25
GEV-06LNPT 1.4	708.1102.110.20	500	1/4	12x1.5	38.0	23.0	14	17	42
GEV-06LNPT 3.8	708.1102.120.20	500	3/8	12x1.5	39.0	24.0	14	19	51
GEV-06LNPT 1.2	708.1102.125.20	500	1/2	12x1.5	44.0	29.0	14	22	82
GEV-08LNPT 1.8	708.1102.160.20	500	1/8	14x1.5	33.0	18.0	17	14	37
GEV-08LNPT 1.4	708.1102.170.20	500	1/4	14x1.5	38.0	23.0	17	17	43
GEV-08LNPT 3.8	708.1102.180.20	500	3/8	14x1.5	39.0	24.0	17	19	60
GEV-08LNPT 1.2	708.1102.185.20	500	1/2	14x1.5	44.0	29.0	17	22	85
GEV-10LNPT 1.8	708.1102.265.20	500	1/8	16x1.5	34.0	19.0	19	17	40
GEV-10LNPT 1.4	708.1102.270.20	500	1/4	16x1.5	39.0	24.0	19	17	55
GEV-10LNPT 3.8	708.1102.280.20	500	3/8	16x1.5	40.0	25.0	19	19	65
GEV-10LNPT 1.2	708.1102.285.20	500	1/2	16x1.5	45.0	30.0	19	22	85
GEV-10LNPT 3.4	708.1102.290.20	500	3/4	16x1.5	46.0	31.0	19	27	120
GEV-12LNPT 1.8	708.1102.375.20	400	1/8	18x1.5	35.0	20.0	22	19	56
GEV-12LNPT 1.4	708.1102.380.20	400	1/4	18x1.5	40.0	25.0	22	19	59
GEV-12LNPT 3.8	708.1102.390.20	400	3/8	18x1.5	40.0	25.0	22	19	66
GEV-12LNPT 1.2	708.1102.400.20	400	1/2	18x1.5	45.0	30.0	22	22	89
GEV-12LNPT 3.4	708.1102.405.20	400	3/4	18x1.5	46.0	31.0	22	27	134
GEV-15LNPT 1.4	708.1102.528.20	400	1/4	22x1.5	41.0	26.0	27	24	90
GEV-15LNPT 3.8	708.1102.532.20	400	3/8	22x1.5	41.0	26.0	27	24	96
GEV-15LNPT 1.2	708.1102.534.20	400	1/2	22x1.5	46.0	31.0	27	24	115
GEV-15LNPT 3.4	708.1102.536.20	400	3/4	22x1.5	47.0	32.0	27	27	154
GEV-15LNPT 1.1	708.1102.541.20	400	1	22x1.5	53.0	38.0	27	36	178
GEV-18LNPT 3.8	708.1102.644.20	400	3/8	26x1.5	43.0	26.5	32	27	138
GEV-18LNPT 1.2	708.1102.646.20	400	1/2	26x1.5	48.0	31.5	32	27	135
GEV-18LNPT 3.4	708.1102.648.20	400	3/4	26x1.5	48.0	31.5	32	27	170
GEV-18LNPT 1.1	708.1102.652.20	400	1	26x1.5	54.0	37.5	32	36	262
GEV-22LNPT 3.8	708.1102.763.20	250	3/8	30x2.0	45.0	28.5	36	32	200
GEV-22LNPT 1.2	708.1102.764.20	250	1/2	30x2.0	50.0	33.5	36	32	194
GEV-22LNPT 3.4	708.1102.768.20	250	3/4	30x2.0	50.0	33.5	36	32	196
GEV-22LNPT 1.1	708.1102.770.20	250	1	30x2.0	56.0	39.5	36	36	282

Fortsetzung auf nächster rechter Seite

To be continued on next right page

Continuación próxima página derecha

D1=Rohr außen-Ø
M1=metrisches Anschlußgewinde

D1=tube outside diameter
M1=metric connecting thread

D1=Ø exterior del tubo
M1=rosca métrica conexión

Gerade Einschraubstutzen NPT
Straight male adaptor connectors NPT
Cuerpos para roscar NPT rectos

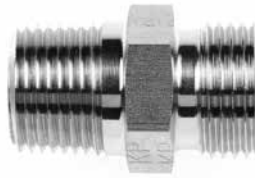
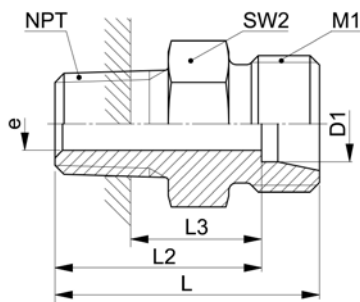

XGEV-..LNPT

Type -D1 NPT	Mat.-Nr.	PN	NPT	M1	L	L2	L3	SW2	e	g/Stk
NPT=Einschraubgewinde NPT		NPT=tapered male adaptor thread NPT			NPT=rosca de conexión cónica NPT					
XGEV-28LNPT 3.4	706.1102.845.20	250	3/4	36x2.0	42.0	34.5	20.5	41	18.0	164
XGEV-28LNPT 1.1	706.1102.850.20	250	1	36x2.0	47.0	39.5	21.5	41	23.0	182
XGEV-28LNPT 5.4	706.1102.860.20	250	1 1/4	36x2.0	49.0	41.5	23.5	46	24.0	310
XGEV-35LNPT 1.1	706.1102.925.20	250	1	45x2.0	50.0	39.5	21.5	46	23.0	280
XGEV-35LNPT 5.4	706.1102.944.20	250	1 1/4	45x2.0	51.0	40.5	22.5	46	30.0	285
XGEV-42LNPT 5.4	706.1102.985.20	250	1 1/4	52x2.0	53.0	42.0	24.0	55	30.0	382
XGEV-42LNPT 3.2	706.1102.992.20	250	1 1/2	52x2.0	53.0	42.0	24.0	55	36.0	358

D1=Rohr außen-Ø
M1=metrisches Anschlußgewinde
e=kleinster Innen-Ø

D1=tube outside diameter
M1=metric connecting thread
e=minimum inside diameter

D1=Ø exterior del tubo
M1=rosca métrica conexión
e=Ø interior mínimo

Gerade Einschraubverschraubungen NPT
Straight male adaptor fittings NPT
Racores para roscar rectos NPT

10

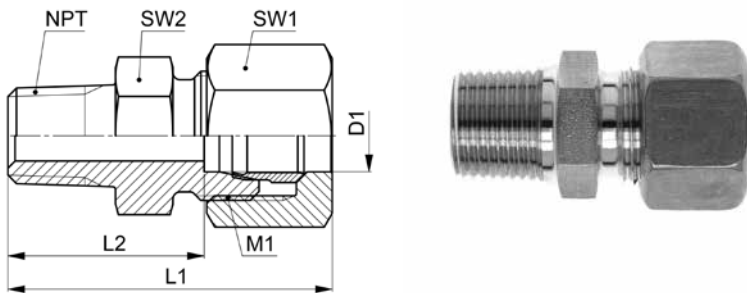

GEV-..LNPT

Type -D1 NPT	Mat.-Nr.	PN	NPT	M1	L1	L2	SW1	SW2	g/Stk
NPT=Einschraubgewinde NPT		NPT=tapered male adaptor thread NPT			NPT=rosca de conexión cónica NPT				
GEV-28LNPT 3.4	708.1102.845.20	250	3/4	36x2.0	51.0	34.5	41	41	270
GEV-28LNPT 1.1	708.1102.850.20	250	1	36x2.0	56.0	39.5	41	41	285
GEV-28LNPT 5.4	708.1102.860.20	250	1 1/4	36x2.0	58.0	41.5	41	46	416
GEV-35LNPT 1.1	708.1102.925.20	250	1	45x2.0	61.0	39.5	50	46	410
GEV-35LNPT 5.4	708.1102.944.20	250	1 1/4	45x2.0	62.0	40.5	50	46	430
GEV-42LNPT 5.4	708.1102.985.20	250	1 1/4	52x2.0	65.0	42.0	60	55	640
GEV-42LNPT 3.2	708.1102.992.20	250	1 1/2	52x2.0	65.0	42.0	60	55	615

Baumaße sind Ungefährmaße bei angezogener Überwurfmutter.

Sizes are approximate dimensions at tightened nut.

Las medidas son aproximadas con la tuerca de unión apretada.

D1=Rohr außen-Ø
M1=metrisches Anschlußgewinde

D1=tube outside diameter
M1=metric connecting thread

D1=Ø exterior del tubo
M1=rosca métrica conexión

Gerade Einschraubstutzen NPT
Straight male adaptor connectors NPT
Cuerpos para roscar NPT rectos

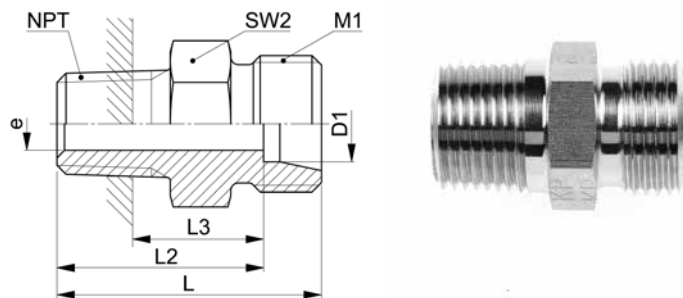

XGEV-..SNPT

Type-D1 NPT	Mat.-Nr.	PN	NPT	M1	L	L2	L3	SW2	e	g/Stk
NPT=Einschraubgewinde NPT		NPT=tapered male adaptor thread NPT			NPT=rosca de conexión cónica NPT					
XGEV-06SNPT 1.8	706.1102.100.30	800	1/8	14x1.5	28.0	21.0	14.0	14	4.0	26
XGEV-06SNPT 1.4	706.1102.110.30	800	1/4	14x1.5	35.0	28.0	18.0	17	4.0	36
XGEV-06SNPT 3.8	706.1102.120.30	800	3/8	14x1.5	35.0	28.0	18.0	19	4.0	50
XGEV-06SNPT 1.2	706.1102.125.30	800	1/2	14x1.5	42.0	35.0	21.0	22	4.0	88
XGEV-08SNPT 1.8	706.1102.160.30	800	1/8	16x1.5	30.0	23.0	16.0	17	5.0	29
XGEV-08SNPT 1.4	706.1102.170.30	800	1/4	16x1.5	35.0	28.0	18.0	17	5.0	36
XGEV-08SNPT 3.8	706.1102.180.30	800	3/8	16x1.5	35.0	28.0	18.0	19	5.0	50
XGEV-08SNPT 1.2	706.1102.185.30	800	1/2	16x1.5	42.0	35.0	21.0	22	5.0	88
XGEV-10SNPT 1.4	706.1102.270.30	800	1/4	18x1.5	35.0	27.5	17.5	19	7.0	40
XGEV-10SNPT 3.8	706.1102.280.30	800	3/8	18x1.5	35.0	27.5	17.5	19	7.0	50
XGEV-10SNPT 1.2	706.1102.285.30	800	1/2	18x1.5	42.0	34.5	20.5	22	7.0	86
XGEV-10SNPT 3.4	706.1102.290.30	800	3/4	18x1.5	42.0	34.5	20.5	27	7.0	125
XGEV-12SNPT 1.4	706.1102.380.30	630	1/4	20x1.5	37.0	29.5	19.5	22	7.0	56
XGEV-12SNPT 3.8	706.1102.390.30	630	3/8	20x1.5	37.0	29.5	19.5	22	8.0	62
XGEV-12SNPT 1.2	706.1102.400.30	630	1/2	20x1.5	42.0	34.5	20.5	22	8.0	86
XGEV-12SNPT 3.4	706.1102.405.30	630	3/4	20x1.5	42.0	34.5	20.5	27	8.0	132
XGEV-14SNPT 3.8	706.1102.502.30	630	3/8	22x1.5	39.0	31.0	21.0	24	10.0	68
XGEV-14SNPT 1.2	706.1102.504.30	630	1/2	22x1.5	44.0	36.0	22.0	24	10.0	92
XGEV-14SNPT 3.4	706.1102.506.30	630	3/4	22x1.5	44.0	36.0	22.0	27	10.0	130
XGEV-14SNPT 1.1	706.1102.510.30	630	1	22x1.5	51.0	43.0	25.0	36	10.0	180
XGEV-16SNPT 3.8	706.1102.564.30	630	3/8	24x1.5	39.0	30.5	20.5	27	9.0	82
XGEV-16SNPT 1.2	706.1102.566.30	630	1/2	24x1.5	44.0	35.5	21.5	27	12.0	94
XGEV-16SNPT 3.4	706.1102.568.30	630	3/4	24x1.5	44.0	35.5	21.5	27	12.0	126
XGEV-16SNPT 1.1	706.1102.570.30	630	1	24x1.5	51.0	42.5	24.5	36	12.0	254
XGEV-20SNPT 1.2	706.1102.706.30	630	1/2	30x2.0	48.0	37.5	23.5	32	12.0	148
XGEV-20SNPT 3.4	706.1102.708.30	420	3/4	30x2.0	48.0	37.5	23.5	32	16.0	154
XGEV-20SNPT 1.1	706.1102.712.30	420	1	30x2.0	53.0	42.5	24.5	36	16.0	248
XGEV-25SNPT 1.2	706.1102.800.30	420	1/2	36x2.0	52.0	40.0	26.0	41	12.0	210
XGEV-25SNPT 3.4	706.1102.805.30	420	3/4	36x2.0	52.0	40.0	26.0	41	16.0	258
XGEV-25SNPT 1.1	706.1102.810.30	420	1	36x2.0	57.0	45.0	27.0	41	20.0	286
XGEV-25SNPT 5.4	706.1102.815.30	420	1 1/4	36x2.0	58.0	46.0	28.0	46	20.0	411
XGEV-25SNPT 3.2	706.1102.820.30	420	1 1/2	36x2.0	58.0	46.0	28.0	50	20.0	490

Fortsetzung auf nächster linker Seite

To be continued on next left page

Continuación próxima página izquierda

D1=Rohr außen-Ø
M1=metrisches Anschlußgewinde
e=kleinster Innen-Ø

D1=tube outside diameter
M1=metric connecting thread
e=minimum inside diameter

D1=Ø exterior del tubo
M1=rosca métrica conexión
e=Ø interior mínimo

Gerade Einschraubverschraubungen NPT
Straight male adaptor fittings NPT
Racores para roscar rectos NPT

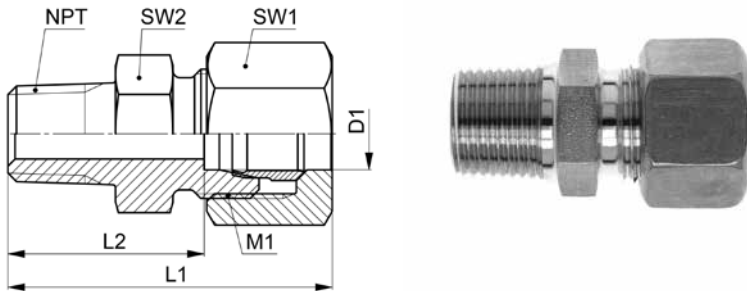

10

GEV-..SNPT

Type-D1 NPT	Mat.-Nr.	PN	NPT	M1	L1	L2	SW1	SW2	g/Stk
NPT=Einschraubgewinde NPT		NPT=tapered male adaptor thread NPT				NPT=rosca de conexión cónica NPT			
GEV-06SNPT 1.8	708.1102.100.30	800	1/8	14x1.5	36.0	21.0	17	14	45
GEV-06SNPT 1.4	708.1102.110.30	800	1/4	14x1.5	43.0	28.0	17	17	55
GEV-06SNPT 3.8	708.1102.120.30	800	3/8	14x1.5	43.0	28.0	17	19	70
GEV-06SNPT 1.2	708.1102.125.30	800	1/2	14x1.5	50.0	35.0	17	22	93
GEV-08SNPT 1.8	708.1102.160.30	800	1/8	16x1.5	38.0	23.0	19	17	48
GEV-08SNPT 1.4	708.1102.170.30	800	1/4	16x1.5	43.0	28.0	19	17	60
GEV-08SNPT 3.8	708.1102.180.30	800	3/8	16x1.5	43.0	28.0	19	19	74
GEV-08SNPT 1.2	708.1102.185.30	800	1/2	16x1.5	50.0	35.0	19	22	108
GEV-10SNPT 1.4	708.1102.270.30	800	1/4	18x1.5	44.0	27.5	22	19	71
GEV-10SNPT 3.8	708.1102.280.30	800	3/8	18x1.5	44.0	27.5	22	19	86
GEV-10SNPT 1.2	708.1102.285.30	800	1/2	18x1.5	51.0	34.5	22	22	104
GEV-10SNPT 3.4	708.1102.290.30	800	3/4	18x1.5	51.0	34.5	22	27	154
GEV-12SNPT 1.4	708.1102.380.30	630	1/4	20x1.5	46.0	29.5	24	22	96
GEV-12SNPT 3.8	708.1102.390.30	630	3/8	20x1.5	46.0	29.5	24	22	100
GEV-12SNPT 1.2	708.1102.400.30	630	1/2	20x1.5	51.0	34.5	24	22	121
GEV-12SNPT 3.4	708.1102.405.30	630	3/4	20x1.5	51.0	34.5	24	27	170
GEV-14SNPT 3.8	708.1102.502.30	630	3/8	22x1.5	49.0	31.0	27	24	125
GEV-14SNPT 1.2	708.1102.504.30	630	1/2	22x1.5	54.0	36.0	27	24	160
GEV-14SNPT 3.4	708.1102.506.30	630	3/4	22x1.5	54.0	36.0	27	27	180
GEV-14SNPT 1.1	708.1102.510.30	630	1	22x1.5	61.0	43.0	27	36	230
GEV-16SNPT 3.8	708.1102.564.30	630	3/8	24x1.5	49.0	30.5	30	27	152
GEV-16SNPT 1.2	708.1102.566.30	630	1/2	24x1.5	54.0	35.5	30	27	170
GEV-16SNPT 3.4	708.1102.568.30	630	3/4	24x1.5	54.0	35.5	30	27	196
GEV-16SNPT 1.1	708.1102.570.30	630	1	24x1.5	61.0	42.5	30	36	324
GEV-20SNPT 1.2	708.1102.706.30	420	1/2	30x2.0	59.0	37.5	36	32	246
GEV-20SNPT 3.4	708.1102.708.30	420	3/4	30x2.0	59.0	37.5	36	32	268
GEV-20SNPT 1.1	708.1102.712.30	420	1	30x2.0	64.0	42.5	36	36	360
GEV-25SNPT 1.2	708.1102.800.30	420	1/2	36x2.0	64.0	40.0	46	41	421
GEV-25SNPT 3.4	708.1102.805.30	420	3/4	36x2.0	64.0	40.0	46	41	474
GEV-25SNPT 1.1	708.1102.810.30	420	1	36x2.0	69.0	45.0	46	41	503
GEV-25SNPT 5.4	708.1102.815.30	420	1 1/4	36x2.0	70.0	46.0	46	46	654
GEV-25SNPT 3.2	708.1102.820.30	420	1 1/2	36x2.0	70.0	46.0	46	50	714

Fortsetzung auf nächster rechter Seite

To be continued on next right page

Continuación próxima página derecha

D1=Rohr außen-Ø
 M1=metrisches Anschlußgewinde

D1=tube outside diameter
 M1=metric connecting thread

D1=Ø exterior del tubo
 M1=rosca métrica conexión

Gerade Einschraubstutzen NPT
Straight male adaptor connectors NPT
Cuerpos para roscar NPT rectos

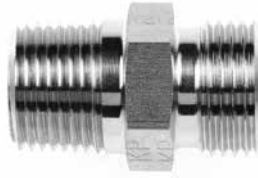
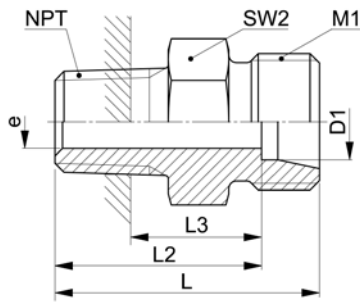

XGEV-..SNPT

Type -D1 NPT	Mat.-Nr.	PN	NPT	M1	L	L2	L3	SW2	e	g/Stk
NPT=Einschraubgewinde NPT		NPT=tapered male adaptor thread NPT			NPT=rosca de conexión cónica NPT					
XGEV-30SNPT 3.4	706.1102.895.30	420	3/4	42x2.0	54.0	40.5	26.5	46	16.0	326
XGEV-30SNPT 1.1	706.1102.900.30	420	1	42x2.0	59.0	45.5	27.5	46	20.0	354
XGEV-30SNPT 5.4	706.1102.902.30	420	1 1/4	42x2.0	60.0	46.5	28.5	46	25.0	410
XGEV-30SNPT 3.2	706.1102.905.30	420	1 1/2	42x2.0	60.0	46.5	28.5	50	25.0	536
XGEV-38SNPT 1.1	706.1102.960.30	420	1	52x2.0	64.0	48.0	30.0	55	20.0	588
XGEV-38SNPT 5.4	706.1102.954.30	420	1 1/4	52x2.0	65.0	49.0	31.0	55	25.0	626
XGEV-38SNPT 3.2	706.1102.953.30	420	1 1/2	52x2.0	65.0	49.0	31.0	55	32.0	586

D1=Rohr außen-Ø
M1=metrisches Anschlußgewinde
e=kleinster Innen-Ø

D1=tube outside diameter
M1=metric connecting thread
e=minimum inside diameter

D1=Ø exterior del tubo
M1=rosca métrica conexión
e=Ø interior mínimo

Gerade Einschraubverschraubungen NPT
Straight male adaptor fittings NPT
Racores para roscar rectos NPT

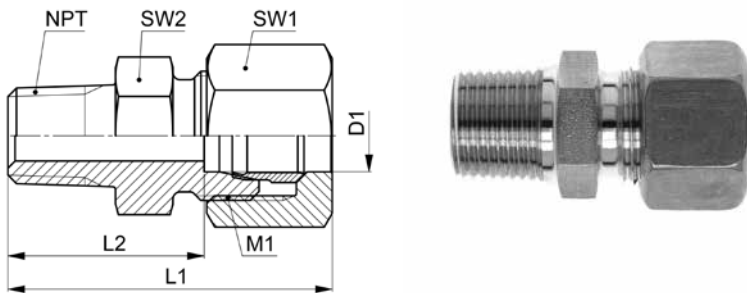

10

GEV-..SNPT

Type -D1 NPT	Mat.-Nr.	PN	NPT	M1	L1	L2	SW1	SW2	g/Stk
NPT=Einschraubgewinde NPT	NPT=tapered male adaptor thread NPT		NPT=rosca de conexión cónica NPT						
GEV-30SNPT 3.4	708.1102.895.30	420	3/4	42x2.0	67.0	40.5	50	46	536
GEV-30SNPT 1.1	708.1102.900.30	420	1	42x2.0	72.0	45.5	50	46	590
GEV-30SNPT 5.4	708.1102.902.30	420	1 1/4	42x2.0	73.0	46.5	50	46	650
GEV-30SNPT 3.2	708.1102.905.30	420	1 1/2	42x2.0	73.0	46.5	50	50	786
GEV-38SNPT 1.1	708.1102.960.30	420	1	52x2.0	79.0	48.0	60	55	955
GEV-38SNPT 5.4	708.1102.954.30	420	1 1/4	52x2.0	80.0	49.0	60	55	955
GEV-38SNPT 3.2	708.1102.953.30	420	1 1/2	52x2.0	80.0	49.0	60	55	935

Baumaße sind Ungefährmaße bei angezogener Überwurfmutter.

Sizes are approximate dimensions at tightened nut.

Las medidas son aproximadas con la tuerca de unión apretada.

D1=Rohr außen-Ø
 M1=metrisches Anschlußgewinde

D1=tube outside diameter
 M1=metric connecting thread

D1=Ø exterior del tubo
 M1=rosca métrica conexión

Winkel-Einschraubstutzen

Abdichtung durch Dichtkante Form B nach DIN 3852-2

Male adaptor elbow connectors

sealing edge form B acc. DIN 3852-2

Cuerpos para roscar en codo

cierre hermético mediante borde de obturación forma B según DIN 3852-2

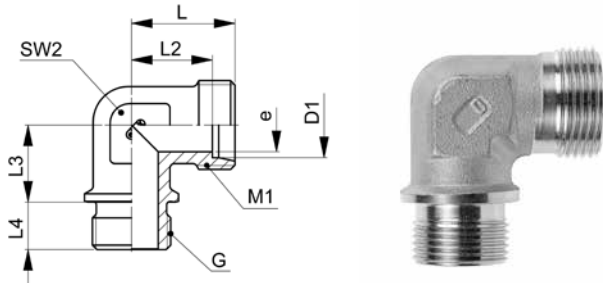

XWEV-..LR/SR

Type-D1 G	Mat.-Nr.	PN	G	M1	L	L2	L3	L4	SW2	e	g/Stk
G=Rohrgewinde (zylindrisch)		G=BSP thread (parallel)			G=rosca de conexión (cilíndrica)						
◇ XWEV-22LR 3.4	706.2406.768.20	250	3/4	30x2.0	35.0	27.5	26.0	16.0	27	18.0	190
◇ XWEV-28LR 1.1	706.2406.850.20	250	1	36x2.0	38.0	30.5	30.0	18.0	36	23.0	333
◇ XWEV-35LR 5.4	706.2406.944.20	250	1 1/4	45x2.0	45.0	34.5	34.0	20.0	41	30.0	498
◇ XWEV-42LR 3.2	706.2406.992.20	250	1 1/2	52x2.0	51.0	40.0	39.0	22.0	50	36.0	722
◇ XWEV-20SR 3.4	706.2406.704.30	420	3/4	30x2.0	37.0	26.5	26.0	16.0	27	16.0	228
◇ XWEV-25SR 1.1	706.2406.810.30	420	1	36x2.0	42.0	30.0	30.0	18.0	36	20.0	415
◇ XWEV-30SR 5.4	706.2406.902.30	420	1 1/4	42x2.0	49.0	35.5	34.0	20.0	41	25.0	670
◇ XWEV-38SR 3.2	706.2406.953.30	420	1 1/2	52x2.0	57.0	41.0	39.0	22.0	50	32.0	960

D1=Rohr außen-Ø
 M1=metrisches Anschlußgewinde
 e=kleinster Innen-Ø
 ◇=entspricht Reihe nach DIN 2353

D1=tube outside diameter
 M1=metric connecting thread
 e=minimum inside diameter
 ◇=according to series DIN 2353

D1=Ø exterior del tubo
 M1=rosca métrica conexión
 e=Ø interior mínimo
 ◇=según serie DIN 2353

Winkel-Einschraubverschraubungen

Abdichtung durch Dichtkante Form B nach DIN 3852-2

Male adaptor elbow fittings

sealing edge form B acc. DIN 3852-2

Racores para roscar en codo

cierre hermético mediante borde de obturación forma B según DIN 3852-2

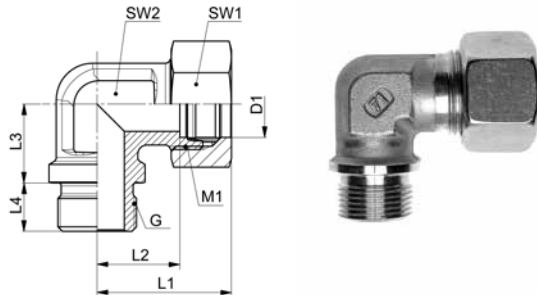

WEV-..LR/SR

Type-D1 G	Mat.-Nr.	PN	G	M1	L1	L2	L3	L4	SW1	SW2	g/Stk
G=Rohrgewinde (zylindrisch)		G=BSP thread (parallel)					G=rosca de conexión (cilíndrica)				
◇ WEV-22LR 3.4	708.2406.768.20	250	3/4	30x2.0	44.0	27.5	26.0	16.0	36	27	267
◇ WEV-28LR 1.1	708.2406.850.20	250	1	36x2.0	47.0	30.5	30.0	18.0	41	36	418
◇ WEV-35LR 5.4	708.2406.944.20	250	1 1/4	45x2.0	56.0	34.5	34.0	20.0	50	41	630
◇ WEV-42LR 3.2	708.2406.992.20	250	1 1/2	52x2.0	63.0	40.0	39.0	22.0	60	50	947
◇ WEV-20SR 3.4	708.2406.704.30	420	3/4	30x2.0	48.0	26.5	26.0	16.0	36	27	329
◇ WEV-25SR 1.1	708.2406.810.30	420	1	36x2.0	54.0	30.0	30.0	18.0	46	36	631
◇ WEV-30SR 5.4	708.2406.902.30	420	1 1/4	42x2.0	62.0	35.5	34.0	20.0	50	41	874
◇ WEV-38SR 3.2	708.2406.953.30	420	1 1/2	52x2.0	72.0	41.0	39.0	22.0	60	50	1225

Baumaße sind Ungefährmaße bei angezogener Überwurfmutter.

Sizes are approximate dimensions at tightened nut.

Las medidas son aproximadas con la tuerca de unión apretada.

D1=Rohr außen-Ø
M1=metrisches Anschlußgewinde
◇=entspricht Reihe nach DIN 2353

D1=tube outside diameter
M1=metric connecting thread
◇=according to series DIN 2353

D1=Ø exterior del tubo
M1=rosca métrica conexión
◇=según serie DIN 2353

Winkel-Einschraubstutzen

Abdichtung im Kegelgewinde Form C nach DIN 3852-2

Male adaptor elbow connectors

taper thread sealing form C acc. DIN 3852-2

Cuerpos para roscar en codo

cierre hermético con rosca cónica forma C según DIN 3852-2

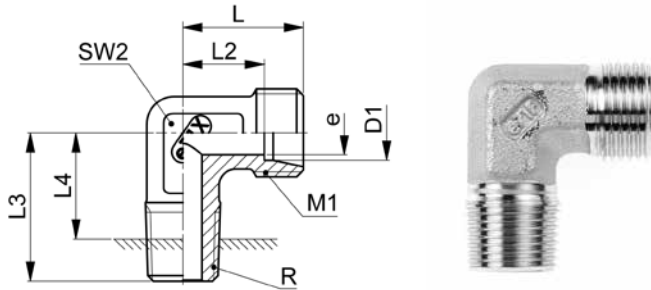

XWEV-..LRK

Type-D1 R	Mat.-Nr.	PN	R	M1	L	L2	L3	L4	SW2	e	g/Stk
R=Rohrgewinde (kegelig)		R=BSP thread (tapered)									
											R=rosca para tubos (cónica)
◇ XWEV-04LLRK 1.8	706.2401.060.10	100	1/8	8x1.0	15.0	11.0	15.0	10.0	9	3.0	11
◇ XWEV-06LLRK 1.8	706.2401.100.10	100	1/8	10x1.0	15.0	9.5	15.0	10.0	9	4.5	10
◇ XWEV-08LLRK 1.8	706.2401.160.10	100	1/8	12x1.0	17.0	11.5	20.0	15.0	12	6.0	16
◇ XWEV-06LRK 1.8	706.2401.100.20	315	1/8	12x1.5	19.0	12.0	20.0	15.0	12	4.0	23
XWEV-06LRK 1.4	706.2401.110.20	315	1/4	12x1.5	19.0	12.0	26.0	18.0	12	4.0	30
XWEV-06LRK 3.8	706.2401.120.20	315	3/8	12x1.5	21.0	14.0	28.0	20.0	14	4.0	56
XWEV-08LRK 1.8	706.2401.160.20	315	1/8	14x1.5	21.0	14.0	26.0	21.0	12	4.0	29
◇ XWEV-08LRK 1.4	706.2401.170.20	315	1/4	14x1.5	21.0	14.0	26.0	18.0	12	6.0	32
XWEV-08LRK 3.8	706.2401.180.20	315	3/8	14x1.5	22.0	15.0	27.0	19.0	14	6.0	44
XWEV-08LRK 1.2	706.2401.185.20	315	1/2	14x1.5	26.0	19.0	30.0	20.0	17	6.0	87
◇ XWEV-10LRK 1.8	706.2401.265.20	315	1/8	16x1.5	22.0	15.0	26.0	21.0	14	4.0	38
◇ XWEV-10LRK 1.4	706.2401.270.20	315	1/4	16x1.5	22.0	15.0	27.0	19.0	14	7.0	40
XWEV-10LRK 3.8	706.2401.280.20	315	3/8	16x1.5	22.0	15.0	27.0	19.0	14	8.0	47
XWEV-10LRK 1.2	706.2401.285.20	315	1/2	16x1.5	28.0	21.0	32.0	22.0	19	8.0	110
XWEV-12LRK 1.4	706.2401.380.20	315	1/4	18x1.5	24.0	17.0	28.0	20.0	17	6.0	55
◇ XWEV-12LRK 3.8	706.2401.390.20	315	3/8	18x1.5	24.0	17.0	28.0	20.0	17	9.0	57
XWEV-12LRK 1.2	706.2401.400.20	315	1/2	18x1.5	28.0	21.0	32.0	22.0	17	10.0	82
XWEV-15LRK 3.8	706.2401.532.20	315	3/8	22x1.5	28.0	21.0	28.0	20.0	19	9.0	86
◇ XWEV-15LRK 1.2	706.2401.534.20	315	1/2	22x1.5	28.0	21.0	34.0	24.0	19	11.0	102
◇ XWEV-18LRK 1.2	706.2401.646.20	315	1/2	26x1.5	31.0	23.5	36.0	26.0	24	14.0	124
XWEV-18LRK 3.4	706.2401.648.20	315	3/4	26x1.5	31.0	23.5	34.0	22.0	24	15.0	145
XWEV-22LRK 3.4	706.2401.768.20	160	3/4	30x2.0	35.0	27.5	42.0	30.0	27	18.0	188

Druckangaben gelten in Verbindung mit zylindrischem Innengewinde.

Pressure information applies in connection with parallel female thread.

Datos de presión válidos en combinación con roscas interiores cilíndricas.

Einbaumaß L4 ist abhängig von den Masstoleranzen des Gegenstückes.

Installation size L4 is dependent on the size tolerances of the counterpart.

Distancia de referencia L4 según las tolerancias dimensionales de la contrapieza.

D1=Rohr außen-Ø
M1=metrisches Anschlußgewinde
e=kleinster Innen-Ø
◇=entspricht Reihe nach DIN 2353

D1=tube outside diameter
M1=metric connecting thread
e=minimum inside diameter
◇=according to series DIN 2353

D1=Ø exterior del tubo
M1=rosca métrica conexión
e=Ø interior mínimo
◇=según serie DIN 2353

Winkel-Einschraubverschraubungen

Abdichtung im Kegengewinde Form C nach DIN 3852-2

Male adaptor elbow fittings

taper thread sealing form C acc. DIN 3852-2

Racores para roscar en codo

cierre hermético con rosca cónica forma C según DIN 3852-2

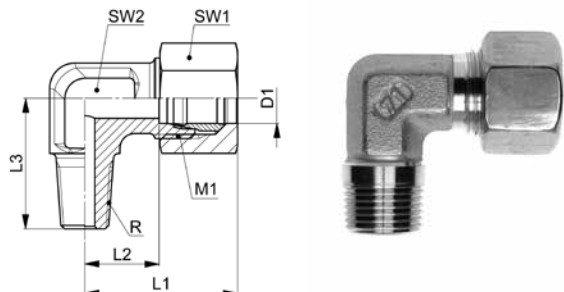

WEV-..LRK

Type-D1 R	Mat.-Nr.	PN	R	M1	L1	L2	L3	SW1	SW2	g/Stk
R=Rohrgewinde (kegelig)		R=BSP thread (tapered)				R=rosca para tubos (cónica)				
◇ WEV-04LLRK 1.8	708.2401.060.10	100	1/8	8x1.0	21.0	11.0	15.0	10	9	21
◇ WEV-06LLRK 1.8	708.2401.100.10	100	1/8	10x1.0	21.0	9.5	15.0	12	9	27
◇ WEV-08LLRK 1.8	708.2401.160.10	100	1/8	12x1.0	23.5	11.5	20.0	14	12	32
◇ WEV-06LRK 1.8	708.2401.100.20	315	1/8	12x1.5	27.0	12.0	20.0	14	12	34
WEV-06LRK 1.4	708.2401.110.20	315	1/4	12x1.5	27.0	12.0	26.0	14	12	57
WEV-06LRK 3.8	708.2401.120.20	315	3/8	12x1.5	29.0	14.0	28.0	14	14	58
WEV-08LRK 1.8	708.2401.160.20	315	1/8	14x1.5	29.0	14.0	26.0	17	12	53
◇ WEV-08LRK 1.4	708.2401.170.20	315	1/4	14x1.5	29.0	14.0	26.0	17	12	60
WEV-08LRK 3.8	708.2401.180.20	315	3/8	14x1.5	30.0	15.0	27.0	17	14	82
WEV-08LRK 1.2	708.2401.185.20	315	1/2	14x1.5	34.0	19.0	30.0	17	17	95
WEV-10LRK 1.8	708.2401.265.20	315	1/8	16x1.5	30.5	15.0	26.0	19	14	64
◇ WEV-10LRK 1.4	708.2401.270.20	315	1/4	16x1.5	30.5	15.0	27.0	19	14	66
WEV-10LRK 3.8	708.2401.280.20	315	3/8	16x1.5	30.5	15.0	27.0	19	14	70
WEV-10LRK 1.2	708.2401.285.20	315	1/2	16x1.5	36.5	21.0	32.0	19	19	90
WEV-12LRK 1.4	708.2401.380.20	315	1/4	18x1.5	32.5	17.0	28.0	22	17	74
◇ WEV-12LRK 3.8	708.2401.390.20	315	3/8	18x1.5	32.5	17.0	28.0	22	17	75
WEV-12LRK 1.2	708.2401.400.20	315	1/2	18x1.5	36.5	21.0	32.0	22	17	110
WEV-15LRK 3.8	708.2401.532.20	315	3/8	22x1.5	37.0	21.0	28.0	27	19	134
◇ WEV-15LRK 1.2	708.2401.534.20	315	1/2	22x1.5	37.5	21.0	34.0	27	19	216
◇ WEV-18LRK 1.2	708.2401.646.20	315	1/2	26x1.5	40.5	23.5	36.0	32	24	273
WEV-18LRK 3.4	708.2401.648.20	160	3/4	26x1.5	40.5	23.5	34.0	32	24	233
WEV-22LRK 3.4	708.2401.768.20	160	3/4	30x2.0	44.5	27.5	42.0	36	27	295

Druckangaben gelten in Verbindung mit zylindrischem Innengewinde.

Pressure information applies in connection with parallel female thread.

Datos de presión válidos en combinación con roscas interiores cilíndricas.

Baumaße sind Ungefährmaße bei angezogener Überwurfmutter.

Sizes are approximate dimensions at tightened nut.

Las medidas son aproximadas con la tuerca de unión apretada.

D1=Rohr außen-Ø
M1=metrisches Anschlußgewinde
◇=entspricht Reihe nach DIN 2353

D1=tube outside diameter
M1=metric connecting thread
◇=according to series DIN 2353

D1=Ø exterior del tubo
M1=rosca métrica conexión
◇=según serie DIN 2353

Winkel-Einschraubstutzen

Abdichtung im Kegengewinde Form C nach DIN 3852-2

Male adaptor elbow connectors

taper thread sealing form C acc. DIN 3852-2

Cuerpos para roscar en codo

cierre hermético con rosca cónica forma C según DIN 3852-2

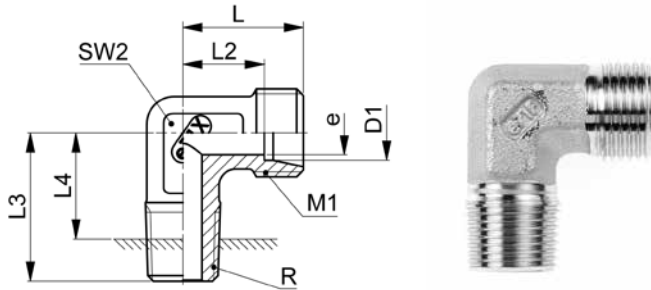

XWEV-..SRK

Type-D1 R	Mat.-Nr.	PN	R	M1	L	L2	L3	L4	SW2	e	g/Stk
R=Rohrgewinde (kegelig)		R=BSP thread (tapered)									
											R=rosca para tubos (cónica)
XWEV-06SRK 1.8	706.2401.100.30	400	1/8	14x1.5	23.0	16.0	26.0	21.0	12	4.0	35
◇ XWEV-06SRK 1.4	706.2401.110.30	400	1/4	14x1.5	23.0	16.0	26.0	18.0	12	4.0	37
XWEV-06SRK 3.8	706.2401.120.30	400	3/8	14x1.5	23.0	16.0	28.0	20.0	14	4.0	55
XWEV-06SRK 1.2	706.2401.125.30	400	1/2	14x1.5	23.0	16.0	29.0	19.0	17	4.0	78
◇ XWEV-08SRK 1.4	706.2401.170.30	400	1/4	16x1.5	24.0	17.0	27.0	19.0	14	5.0	53
XWEV-08SRK 3.8	706.2401.180.30	400	3/8	16x1.5	24.0	17.0	27.0	19.0	14	5.0	58
XWEV-08SRK 1.2	706.2401.185.30	400	1/2	16x1.5	26.0	19.0	30.0	20.0	17	6.0	91
XWEV-10SRK 1.4	706.2401.270.30	400	1/4	18x1.5	25.0	17.5	27.0	19.0	17	6.0	63
◇ XWEV-10SRK 3.8	706.2401.280.30	400	3/8	18x1.5	25.0	17.5	28.0	20.0	17	7.0	71
XWEV-10SRK 1.2	706.2401.285.30	400	1/2	18x1.5	25.0	17.5	32.0	22.0	19	7.0	110
◇ XWEV-12SRK 3.8	706.2401.390.30	400	3/8	20x1.5	29.0	21.5	28.0	20.0	17	8.0	83
XWEV-12SRK 1.2	706.2401.400.30	400	1/2	20x1.5	29.0	21.5	32.0	22.0	17	8.0	96
XWEV-14SRK 3.8	706.2401.502.30	400	3/8	22x1.5	30.0	22.0	32.0	24.0	19	10.0	99
XWEV-14SRK 1.2	706.2401.504.30	400	1/2	22x1.5	30.0	22.0	32.0	22.0	19	10.0	113
◇ XWEV-16SRK 1.2	706.2401.566.30	400	1/2	24x1.5	33.0	24.5	32.0	22.0	24	12.0	131

Druckangaben gelten in Verbindung mit zylindrischem Innengewinde.

Pressure information applies in connection with parallel female thread.

Datos de presión válidos en combinación con roscas interiores cilíndricas.

Einbaumaß L4 ist abhängig von den Masstoleranzen des Gegenstückes.

Installation size L4 is dependent on the size tolerances of the counterpart.

Distancia de referencia L4 según las tolerancias dimensionales de la contrapieza.

D1=Rohr außen-Ø
 M1=metrisches Anschlußgewinde
 e=kleinster Innen-Ø
 ◇=entspricht Reihe nach DIN 2353

D1=tube outside diameter
 M1=metric connecting thread
 e=minimum inside diameter
 ◇=according to series DIN 2353

D1=Ø exterior del tubo
 M1=rosca métrica conexión
 e=Ø interior mínimo
 ◇=según serie DIN 2353

Winkel-Einschraubverschraubungen

Abdichtung im Kegelgewinde Form C nach DIN 3852-2

Male adaptor elbow fittings

taper thread sealing form C acc. DIN 3852-2

Racores para roscar en codo

cierre hermético con rosca cónica forma C según DIN 3852-2

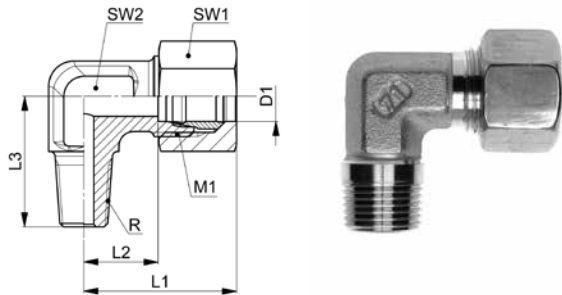

WEV-..SRK

Type-D1 R	Mat.-Nr.	PN	R	M1	L1	L2	L3	SW1	SW2	g/Stk
R=Rohrgewinde (kegelig)		R=BSP thread (tapered)				R=rosca para tubos (cónica)				
WEV-06SRK 1.8	708.2401.100.30	400	1/8	14x1.5	31.0	16.0	26.0	17	12	59
◇ WEV-06SRK 1.4	708.2401.110.30	400	1/4	14x1.5	31.0	16.0	26.0	17	12	61
WEV-06SRK 3.8	708.2401.120.30	400	3/8	14x1.5	31.0	16.0	28.0	17	14	80
WEV-06SRK 1.2	708.2401.125.30	400	1/2	14x1.5	31.0	16.0	29.0	17	17	101
◇ WEV-08SRK 1.4	708.2401.170.30	400	1/4	16x1.5	32.0	17.0	27.0	19	14	79
WEV-08SRK 3.8	708.2401.180.30	400	3/8	16x1.5	32.0	17.0	27.0	19	14	85
WEV-08SRK 1.2	708.2401.185.30	400	1/2	16x1.5	34.0	19.0	30.0	19	17	102
WEV-10SRK 1.4	708.2401.270.30	400	1/4	18x1.5	34.5	17.5	27.0	22	17	92
◇ WEV-10SRK 3.8	708.2401.280.30	400	3/8	18x1.5	34.5	17.5	28.0	22	17	95
WEV-10SRK 1.2	708.2401.285.30	400	1/2	18x1.5	34.5	17.5	32.0	22	17	131
◇ WEV-12SRK 3.8	708.2401.390.30	400	3/8	20x1.5	38.5	21.5	28.0	24	17	115
WEV-12SRK 1.2	708.2401.400.30	400	1/2	20x1.5	38.5	21.5	32.0	24	17	130
WEV-14SRK 3.8	708.2401.502.30	400	3/8	22x1.5	40.5	22.0	32.0	27	19	147
WEV-14SRK 1.2	708.2401.504.30	400	1/2	22x1.5	40.5	22.0	32.0	27	19	158
◇ WEV-16SRK 1.2	708.2401.566.30	400	1/2	24x1.5	44.0	24.5	32.0	30	24	200

Druckangaben gelten in Verbindung mit zylindrischem Innengewinde.

Pressure information applies in connection with parallel female thread.

Datos de presión válidos en combinación con roscas interiores cilíndricas.

Baumaße sind Ungefährmaße bei angezogener Überwurfmutter.

Sizes are approximate dimensions at tightened nut.

Las medidas son aproximadas con la tuerca de unión apretada.

D1=Rohr außen-Ø
M1=metrisches Anschlußgewinde
◇=entspricht Reihe nach DIN 2353

D1=tube outside diameter
M1=metric connecting thread
◇=according to series DIN 2353

D1=Ø exterior del tubo
M1=rosca métrica conexión
◇=según serie DIN 2353

Winkel-Einschraubstutzen

Abdichtung im Kegengewinde Form C nach DIN 3852-2

Male adaptor elbow connectors

taper thread sealing form C acc. DIN 3852-2

Cuerpos para roscar en codo

cierre hermético con rosca cónica forma C según DIN 3852-2

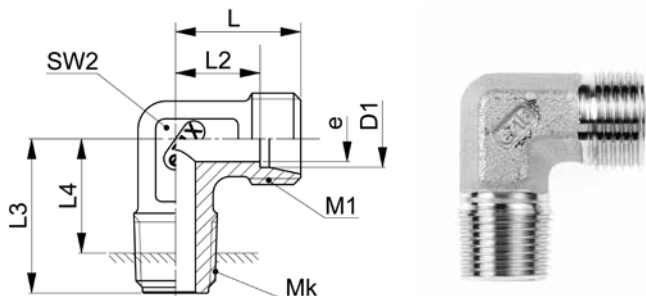

XWEV-..LMK/SMK

Type-D1 Mk	Mat.-Nr.	PN	Mk	M1	L	L2	L3	L4	SW2	e	g/Stk
Mk=metrisches Gewinde (kegelig)	Mk=metric thread (tapered)										
											Mk=rosca métrica (cónica)
◇ XWEV-04LLMK 08x1,0	706.2403.090.10	100	08x1.0	8x1.0	15.0	11.0	17.0	11.5	9	3.0	12
XWEV-06LLMK 08x1,0	706.2403.170.10	100	08x1.0	10x1.0	15.0	9.5	17.0	11.5	9	3.5	11
◇ XWEV-06LLMK 10x1,0	706.2403.180.10	100	10x1.0	10x1.0	15.0	9.5	17.0	11.5	9	4.5	12
XWEV-08LLMK 08x1,0	706.2403.225.10	100	08x1.0	12x1.0	17.0	11.5	17.0	11.5	12	3.5	16
◇ XWEV-08LLMK 10x1,0	706.2403.230.10	250	10x1.0	12x1.0	17.0	11.5	20.0	14.5	12	6.0	17
◇ XWEV-06LMK 10x1,0	706.2403.180.20	250	10x1.0	12x1.5	19.0	12.0	20.0	14.5	12	4.0	24
◇ XWEV-08LMK 12x1,5	706.2403.240.20	250	12x1.5	14x1.5	21.0	14.0	26.0	17.5	12	6.0	29
◇ XWEV-10LMK 14x1,5	706.2403.278.20	250	14x1.5	16x1.5	22.0	15.0	27.0	18.5	14	7.0	42
◇ XWEV-12LMK 16x1,5	706.2403.330.20	250	16x1.5	18x1.5	24.0	17.0	28.0	19.5	17	9.0	55
◇ XWEV-15LMK 18x1,5	706.2403.390.20	250	18x1.5	26x1.5	28.0	21.0	32.0	23.5	19	10.0	92
◇ XWEV-18LMK 22x1,5	706.2403.460.20	160	22x1.5	26x1.5	31.0	23.5	36.0	27.5	24	14.0	131
◇ XWEV-06SMK 12x1,5	706.2403.190.30	400	12x1.5	14x1.5	23.0	16.0	26.0	17.5	12	4.0	38
◇ XWEV-08SMK 14x1,5	706.2403.245.30	400	14x1.5	16x1.5	24.0	17.0	27.0	18.5	14	5.0	54
◇ XWEV-10SMK 16x1,5	706.2403.285.30	400	16x1.5	18x1.5	25.0	17.5	28.0	19.5	17	7.0	69
◇ XWEV-12SMK 18x1,5	706.2403.333.30	400	18x1.5	20x1.5	29.0	21.5	28.0	19.5	17	8.0	86
XWEV-14SMK 20x1,5	706.2403.382.30	400	20x1.5	22x1.5	30.0	22.0	32.0	23.5	19	10.0	110

Druckangaben gelten in Verbindung mit zylindrischem Innengewinde.

Pressure information applies in connection with parallel female thread.

Datos de presión válidos en combinación con roscas interiores cilíndricas.

Einbaumaß L4 ist abhängig von den Masstoleranzen des Gegenstückes.

Installation size L4 is dependent on the size tolerances of the counterpart.

Distancia de referencia L4 según las tolerancias dimensionales de la contrapieza.

D1=Rohr außen-Ø
M1=metrisches Anschlußgewinde
e=kleinster Innen-Ø
◇=entspricht Reihe nach DIN 2353

D1=tube outside diameter
M1=metric connecting thread
e=minimum inside diameter
◇=according to series DIN 2353

D1=Ø exterior del tubo
M1=rosca métrica conexión
e=Ø interior mínimo
◇=según serie DIN 2353

Winkel-Einschraubverschraubungen

Abdichtung im Kegengewinde Form C nach DIN 3852-2

Male adaptor elbow fittings

taper thread sealing form C acc. DIN 3852-2

Racores para roscar en codo

cierre hermético con rosca cónica forma C según DIN 3852-2

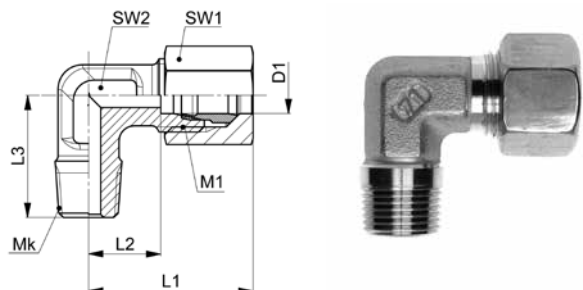

10

WEV-..LMK/SMK

Type-D1 Mk	Mat.-Nr.	PN	Mk	M1	L1	L2	L3	SW1	SW2	g/Stk
Mk=metrisches Gewinde (kegelig)	Mk=metric thread (tapered)									
										Mk=rosca métrica (cónica)
◇ WEV-04LLMK 08x1,0	708.2403.090.10	100	08x1.0	8x1.0	21.0	11.0	17.0	10	9	17
WEV-06LLMK 08x1,0	708.2403.170.10	100	08x1.0	10x1.0	21.0	9.5	17.0	12	9	18
◇ WEV-06LLMK 10x1,0	708.2403.180.10	100	10x1.0	10x1.0	21.0	9.5	17.0	12	9	20
WEV-08LLMK 08x1,0	708.2403.225.10	100	08x1.0	12x1.0	23.5	11.5	17.0	14	12	22
◇ WEV-08LLMK 10x1,0	708.2403.230.10	100	10x1.0	12x1.0	23.5	11.5	20.0	14	12	24
◇ WEV-06LMK 10x1,0	708.2403.180.20	315	10x1.0	12x1.5	27.0	12.0	20.0	14	12	32
◇ WEV-08LMK 12x1,5	708.2403.240.20	315	12x1.5	14x1.5	29.0	14.0	26.0	17	12	43
◇ WEV-10LMK 14x1,5	708.2403.278.20	315	14x1.5	16x1.5	30.5	15.0	27.0	19	14	61
◇ WEV-12LMK 16x1,5	708.2403.330.20	315	16x1.5	18x1.5	32.5	17.0	28.0	22	17	80
◇ WEV-15LMK 18x1,5	708.2403.390.20	315	18x1.5	26x1.5	37.0	21.0	32.0	27	19	136
◇ WEV-18LMK 22x1,5	708.2403.460.20	315	22x1.5	26x1.5	40.5	23.5	36.0	32	24	188
◇ WEV-06SMK 12x1,5	708.2403.190.30	400	12x1.5	14x1.5	31.0	16.0	26.0	17	12	55
◇ WEV-08SMK 14x1,5	708.2403.245.30	400	14x1.5	16x1.5	32.0	17.0	27.0	19	14	70
◇ WEV-10SMK 16x1,5	708.2403.285.30	400	16x1.5	18x1.5	34.5	17.5	28.0	22	17	98
◇ WEV-12SMK 18x1,5	708.2403.333.30	400	18x1.5	20x1.5	38.5	21.5	28.0	24	17	118
WEV-14SMK 20x1,5	708.2403.382.30	400	20x1.5	22x1.5	40.5	22.0	32.0	27	19	154

Druckangaben gelten in Verbindung mit zylindrischem Innengewinde.

Pressure information applies in connection with parallel female thread.

Datos de presión válidos en combinación con roscas interiores cilíndricas.

Baumaße sind Ungefährmaße bei angezogener Überwurfmutter.

Sizes are approximate dimensions at tightened nut.

Las medidas son aproximadas con la tuerca de unión apretada.

D1=Rohr außen-Ø
M1=metrisches Anschlußgewinde
◇=entspricht Reihe nach DIN 2353

D1=tube outside diameter
M1=metric connecting thread
◇=according to series DIN 2353

D1=Ø exterior del tubo
M1=rosca métrica conexión
◇=según serie DIN 2353

Winkel-Einschraubstutzen NPT

Male adaptor elbow connectors NPT

Cuerpos para roscar en codo NPT

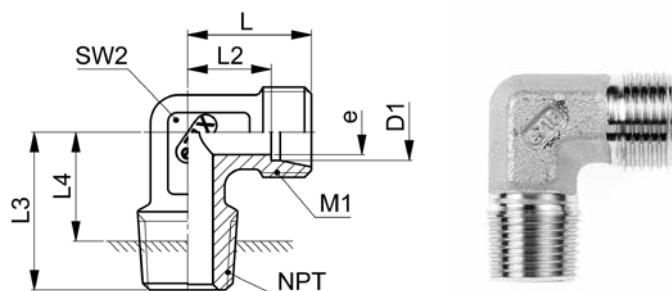

XWEV-..LNPT

Type-D1 NPT	Mat.-Nr.	PN	NPT	M1	L	L2	L3	L4	SW2	e	g/Stk
NPT=Einschraubgewinde NPT		NPT=tapered male adaptor thread NPT				NPT=rosca de conexión cónica NPT					
XWEV-04LLNPT 1.8	706.2402.060.10	100	1/8	8x1.0	15.0	11.0	17.0	8.0	9	3.0	13
XWEV-06LLNPT 1.8	706.2402.100.10	100	1/8	10x1.0	15.0	9.5	17.0	8.0	9	4.5	12
XWEV-08LLNPT 1.8	706.2402.160.10	100	1/8	12x1.0	17.0	11.5	20.0	10.0	12	6.0	17
XWEV-06LNPT 1.8	706.2402.100.20	500	1/8	12x1.5	19.0	12.0	20.0	12.0	12	4.0	22
XWEV-06LNPT 1.4	706.2402.110.20	500	1/4	12x1.5	17.0	10.0	25.5	7.0	12	4.0	26
XWEV-06LNPT 3.8	706.2402.120.20	500	3/8	12x1.5	21.0	14.0	28.0	11.0	14	4.0	44
XWEV-08LNPT 1.8	706.2402.160.20	500	1/8	14x1.5	21.0	14.0	24.0	14.0	12	4.0	28
XWEV-08LNPT 1.4	706.2402.170.20	500	1/4	14x1.5	21.0	14.0	26.0	11.0	12	6.0	32
XWEV-08LNPT 3.8	706.2402.180.20	500	3/8	14x1.5	22.0	15.0	28.0	12.0	14	6.0	47
XWEV-08LNPT 1.2	706.2402.185.20	500	1/2	14x1.5	26.0	19.0	34.0	12.0	17	6.0	95
XWEV-10LNPT 1.4	706.2402.270.20	500	1/4	16x1.5	22.0	15.0	26.0	12.0	14	7.0	40
XWEV-10LNPT 3.8	706.2402.280.20	500	3/8	16x1.5	22.0	15.0	28.0	12.0	14	8.0	45
XWEV-10LNPT 1.2	706.2402.285.20	400	1/2	16x1.5	28.0	21.0	30.0	14.0	17	8.0	88
XWEV-12LNPT 1.4	706.2402.380.20	400	1/4	18x1.5	24.0	17.0	26.0	14.0	17	7.0	52
XWEV-12LNPT 3.8	706.2402.390.20	400	3/8	18x1.5	24.0	17.0	28.0	14.0	17	9.0	58
XWEV-12LNPT 1.2	706.2402.400.20	400	1/2	18x1.5	28.0	21.0	34.0	14.0	17	10.0	85
XWEV-15LNPT 1.2	706.2402.534.20	400	1/2	22x1.5	28.0	21.0	34.0	14.0	19	10.0	106
XWEV-18LNPT 1.2	706.2402.646.20	400	1/2	26x1.5	31.0	23.5	36.0	17.0	24	14.0	124
XWEV-18LNPT 3.4	706.2402.648.20	250	3/4	26x1.5	31.0	23.5	36.0	17.0	24	15.0	146
XWEV-22LNPT 3.4	706.2402.768.20	250	3/4	30x2.0	35.0	27.5	42.0	21.0	27	18.0	186
XWEV-28LNPT 1.1	706.2402.850.20	250	1	36x2.0	38.0	30.5	48.0	20.0	36	23.0	334
XWEV-35LNPT 5.4	706.2402.944.20	250	1 1/4	45x2.0	45.0	34.5	54.0	27.0	41	30.0	474
XWEV-42LNPT 3.2	706.2402.992.20	250	1 1/2	52x2.0	51.0	40.0	61.0	33.0	50	36.0	704

D1=Rohr außen-Ø
M1=metrisches Anschlußgewinde
e=kleinster Innen-Ø

D1=tube outside diameter
M1=metric connecting thread
e=minimum inside diameter

D1=Ø exterior del tubo
M1=rosca métrica conexión
e=Ø interior mínimo

Winkel-Einschraubverschraubungen NPT

Male adaptor elbow fittings NPT

Racores para roscar en codo NPT

10

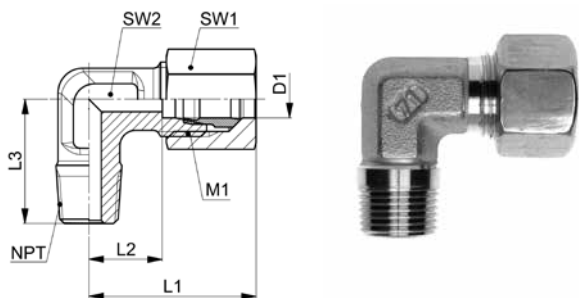

WEV-..LNPT

Type-D1 NPT	Mat.-Nr.	PN	NPT	M1	L1	L2	L3	SW1	SW2	g/Stk
NPT=Einschraubgewinde NPT		NPT=tapered male adaptor thread NPT			NPT=rosca de conexión cónica NPT					
WEV-04LLNPT 1.8	708.2402.060.10	100	1/8	8x1.0	21.0	11.0	17.0	10	9	17
WEV-06LLNPT 1.8	708.2402.100.10	100	1/8	10x1.0	21.0	9.5	17.0	12	9	18
WEV-08LLNPT 1.8	708.2402.160.10	100	1/8	12x1.0	23.0	11.5	20.0	14	12	24
WEV-06LNPT 1.8	708.2402.100.20	500	1/8	12x1.5	27.0	12.0	20.0	14	12	32
WEV-06LNPT 1.4	708.2402.110.20	500	1/4	12x1.5	25.0	10.0	25.5	14	12	36
WEV-06LNPT 3.8	708.2402.120.20	500	3/8	12x1.5	29.0	14.0	28.0	14	14	52
WEV-08LNPT 1.8	708.2402.160.20	500	1/8	14x1.5	29.0	14.0	24.0	17	12	42
WEV-08LNPT 1.4	708.2402.170.20	500	1/4	14x1.5	29.0	14.0	26.0	17	12	44
WEV-08LNPT 3.8	708.2402.180.20	500	3/8	14x1.5	30.0	15.0	28.0	17	14	71
WEV-08LNPT 1.2	708.2402.185.20	500	1/2	14x1.5	34.0	19.0	34.0	17	17	104
WEV-10LNPT 1.4	708.2402.270.20	500	1/4	16x1.5	30.0	15.0	26.0	19	14	56
WEV-10LNPT 3.8	708.2402.280.20	500	3/8	16x1.5	30.0	15.0	28.0	19	14	60
WEV-10LNPT 1.2	708.2402.285.20	500	1/2	16x1.5	36.5	21.0	30.0	19	17	100
WEV-12LNPT 1.4	708.2402.380.20	400	1/4	18x1.5	32.0	17.0	26.0	22	17	76
WEV-12LNPT 3.8	708.2402.390.20	400	3/8	18x1.5	32.0	17.0	28.0	22	17	76
WEV-12LNPT 1.2	708.2402.400.20	400	1/2	18x1.5	36.5	21.0	34.0	22	17	118
WEV-15LNPT 1.2	708.2402.534.20	400	1/2	22x1.5	36.0	21.0	34.0	27	19	138
WEV-18LNPT 1.2	708.2402.646.20	400	1/2	26x1.5	40.0	23.5	36.0	32	24	184
WEV-18LNPT 3.4	708.2402.648.20	400	3/4	26x1.5	40.0	23.5	36.0	32	24	200
WEV-22LNPT 3.4	708.2402.768.20	250	3/4	30x2.0	44.5	27.5	42.0	36	27	252
WEV-28LNPT 1.1	708.2402.850.20	250	1	36x2.0	47.0	30.5	48.0	41	36	420
WEV-35LNPT 5.4	708.2402.944.20	250	1 1/4	45x2.0	56.0	34.5	54.0	50	41	587
WEV-42LNPT 3.2	708.2402.992.20	250	1 1/2	52x2.0	63.0	40.0	61.0	60	50	845

Baumaße sind Ungefährmaße bei angezogener Überwurfmutter.

Sizes are approximate dimensions at tightened nut.

Las medidas son aproximadas con la tuerca de unión apretada.

D1=Rohr außen-Ø
M1=metrisches Anschlußgewinde

D1=tube outside diameter
M1=metric connecting thread

D1=Ø exterior del tubo
M1=rosca métrica conexión

Winkel-Einschraubstutzen NPT

Male adaptor elbow connectors NPT

Cuerpos para roscar en codo NPT

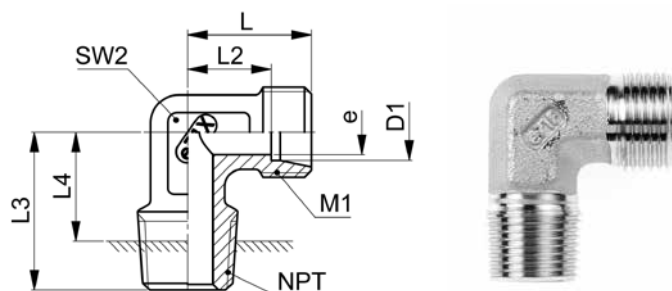

XWEV-..SNPT

Type-D1 NPT	Mat.-Nr.	PN	NPT	M1	L	L2	L3	L4	SW2	e	g/Stk
NPT=Einschraubgewinde NPT		NPT=tapered male adaptor thread NPT			NPT=rosca de conexión cónica NPT						
XWEV-06SNPT 1.4	706.2402.110.30	800	1/4	14x1.5	23.0	16.0	26.0	15.0	12	4.0	40
XWEV-06SNPT 3.8	706.2402.120.30	800	3/8	14x1.5	23.0	16.0	28.0	15.0	14	4.0	56
XWEV-06SNPT 1.2	706.2402.125.30	800	1/2	14x1.5	23.0	16.0	33.0	13.0	17	4.0	93
XWEV-08SNPT 1.4	706.2402.170.30	800	1/4	16x1.5	24.0	17.0	26.0	16.0	14	5.0	52
XWEV-08SNPT 3.8	706.2402.180.30	800	3/8	16x1.5	25.0	18.0	28.0	17.0	17	5.0	71
XWEV-08SNPT 1.2	706.2402.185.30	800	1/2	16x1.5	28.0	21.0	34.0	18.0	17	6.0	103
XWEV-10SNPT 1.4	706.2402.270.30	800	1/4	18x1.5	25.0	17.5	26.0	17.0	17	7.0	61
XWEV-10SNPT 3.8	706.2402.280.30	800	3/8	18x1.5	25.0	17.5	28.0	17.0	17	7.0	72
XWEV-12SNPT 1.4	706.2402.380.30	630	1/4	20x1.5	29.0	21.5	27.0	21.0	17	7.0	75
XWEV-12SNPT 3.8	706.2402.390.30	630	3/8	20x1.5	29.0	21.5	28.0	21.0	17	8.0	83
XWEV-12SNPT 1.2	706.2402.400.30	630	1/2	20x1.5	29.0	21.5	33.0	19.0	17	8.0	104
XWEV-14SNPT 3.8	706.2402.502.30	630	3/8	22x1.5	30.0	22.0	28.0	22.0	19	8.0	99
XWEV-14SNPT 1.2	706.2402.504.30	630	1/2	22x1.5	30.0	22.0	34.0	20.0	19	10.0	117
XWEV-16SNPT 1.2	706.2402.655.30	630	1/2	24x1.5	33.0	24.5	36.0	13.0	24	12.0	149
XWEV-20SNPT 3.4	706.2402.708.30	420	3/4	30x2.0	37.0	26.5	42.0	25.0	27	16.0	223
XWEV-25SNPT 1.1	706.2402.810.30	420	1	36x2.0	42.0	30.0	48.0	28.0	36	20.0	403
XWEV-30SNPT 5.4	706.2402.902.30	420	1 1/4	42x2.0	49.0	35.5	54.0	35.0	41	25.0	645
XWEV-38SNPT 3.2	706.2402.953.30	420	1 1/2	52x2.0	57.0	41.0	61.0	43.0	50	32.0	914

D1=Rohr außen-Ø
M1=metrisches Anschlußgewinde
e=kleinster Innen-Ø

D1=tube outside diameter
M1=metric connecting thread
e=minimum inside diameter

D1=Ø exterior del tubo
M1=rosca métrica conexión
e=Ø interior mínimo

Winkel-Einschraubverschraubungen NPT

Male adaptor elbow fittings NPT

Racores para roscar en codo NPT

10

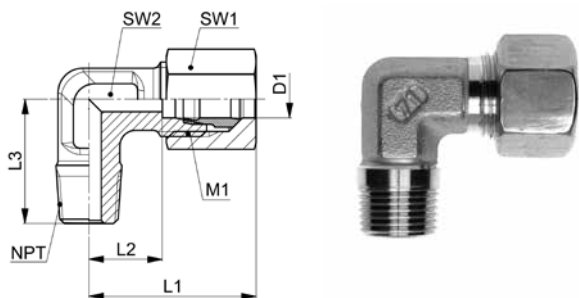

WEV-..SNPT

Type-D1 NPT	Mat.-Nr.	PN	NPT	M1	L1	L2	L3	SW1	SW2	g/Stk
NPT=Einschraubgewinde NPT		NPT=tapered male adaptor thread NPT			NPT=rosca de conexión cónica NPT					
WEV-06SNPT 1.4	708.2402.110.30	800	1/4	14x1.5	31.0	16.3	26.0	17	12	54
WEV-06SNPT 3.8	708.2402.120.30	800	3/8	14x1.5	31.0	16.0	28.0	17	14	70
WEV-06SNPT 1.2	708.2402.125.30	800	1/2	14x1.5	31.0	16.0	33.0	17	17	99
WEV-08SNPT 1.4	708.2402.170.30	800	1/4	16x1.5	32.5	17.0	26.0	19	14	68
WEV-08SNPT 3.8	708.2402.180.30	800	3/8	16x1.5	33.0	18.0	28.0	19	17	76
WEV-08SNPT 1.2	708.2402.185.30	800	1/2	16x1.5	36.0	21.0	34.0	19	17	133
WEV-10SNPT 1.4	708.2402.270.30	800	1/4	18x1.5	34.5	17.5	26.0	22	17	88
WEV-10SNPT 3.8	708.2402.280.30	800	3/8	18x1.5	34.5	17.5	28.0	22	17	98
WEV-12SNPT 1.4	708.2402.380.30	630	1/4	20x1.5	38.0	21.5	27.0	24	17	104
WEV-12SNPT 3.8	708.2402.390.30	630	3/8	20x1.5	38.0	21.5	28.0	24	17	112
WEV-12SNPT 1.2	708.2402.400.30	630	1/2	20x1.5	39.0	21.5	33.0	24	17	132
WEV-14SNPT 3.8	708.2402.502.30	630	3/8	22x1.5	40.5	22.0	28.0	27	19	148
WEV-14SNPT 1.2	708.2402.504.30	630	1/2	22x1.5	40.0	22.0	34.0	27	19	158
WEV-16SNPT 1.2	708.2402.655.30	630	1/2	24x1.5	43.0	24.5	36.0	30	24	206
WEV-20SNPT 3.4	708.2402.708.30	420	3/4	30x2.0	49.5	26.5	42.0	36	27	318
WEV-25SNPT 1.1	708.2402.810.30	420	1	36x2.0	55.5	30.0	48.0	46	36	616
WEV-30SNPT 5.4	708.2402.902.30	420	1 1/4	42x2.0	63.5	35.5	54.0	50	41	829
WEV-38SNPT 3.2	708.2402.953.30	420	1 1/2	52x2.0	74.0	41.0	61.0	60	50	1175

Baumaße sind Ungefährmaße bei angezogener Überwurfmutter.

Sizes are approximate dimensions at tightened nut.

Las medidas son aproximadas con la tuerca de unión apretada.

D1=Rohr außen-Ø
M1=metrisches Anschlußgewinde

D1=tube outside diameter
M1=metric connecting thread

D1=Ø exterior del tubo
M1=rosca métrica conexión

T-Einschraubstutzen

Abdichtung durch Dichtkante Form B nach DIN 3852-2

Male adaptor T connectors

sealing edge form B acc. DIN 3852-2

Cuerpos para roscar T

cierre hermético mediante borde de obturación forma B según DIN 3852-2

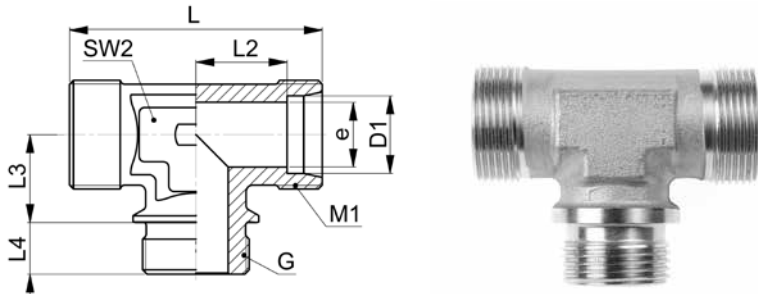

XTEV-..LR/SR

Type-D1 G	Mat.-Nr.	PN	G	M1	L	L2	L3	L4	SW2	e	g/Stk
G=Rohrgewinde (zylindrisch)		G=BSP thread (parallel)						G=rosca de conexión (cilíndrica)			
◇ XTEV-22LR 3.4	706.3702.768.20	250	3/4	30x2.0	70.0	27.5	26.0	16.0	27	18.0	233
◇ XTEV-28LR 1.1	706.3702.850.20	250	1	36x2.0	76.0	30.5	30.0	18.0	36	23.0	400
◇ XTEV-42LR 3.2	706.3702.992.20	250	1 1/2	52x2.0	102.0	40.0	39.0	22.0	50	36.0	872
◇ XTEV-20SR 3.4	706.3702.704.30	420	3/4	30x2.0	74.0	26.5	26.0	16.0	27	16.0	298
◇ XTEV-38SR 3.2	706.3702.953.30	420	1 1/2	52x2.0	114.0	41.0	39.0	22.0	50	32.0	1218

D1=Rohr außen-Ø
M1=metrisches Anschlußgewinde
e=kleinster Innen-Ø
◇=entspricht Reihe nach DIN 2353

D1=tube outside diameter
M1=metric connecting thread
e=minimum inside diameter
◇=according to series DIN 2353

D1=Ø exterior del tubo
M1=rosca métrica conexión
e=Ø interior mínimo
◇=según serie DIN 2353

T-Einschraubverschraubungen

Abdichtung durch Dichtkante Form B nach DIN 3852-2

Male adaptor T fittings

sealing edge form B acc. DIN 3852-2

Racores para roscar T

cierre hermético mediante borde de obturación forma B según DIN 3852-2

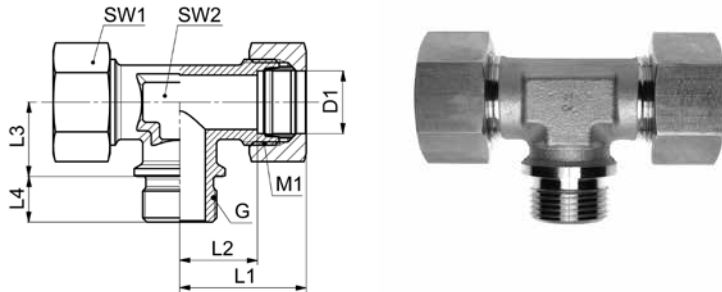

TEV-..LR/SR

Type-D1 G	Mat.-Nr.	PN	G	M1	L1	L2	L3	L4	SW1	SW2	g/Stk
G=Rohrgewinde (zylindrisch)		G=BSP thread (parallel)					G=rosca de conexión (cilíndrica)				
◇ TEV-22LR 3.4	708.3702.768.20	250	3/4	30x2.0	44.5	27.5	26.0	16.0	36	27	381
◇ TEV-28LR 1.1	708.3702.850.20	250	1	36x2.0	47.5	30.5	30.0	18.0	41	36	544
◇ TEV-42LR 3.2	708.3702.992.20	250	1 1/2	52x2.0	63.5	40.0	39.0	22.0	60	50	1408
◇ TEV-20SR 3.4	708.3702.704.30	420	3/4	30x2.0	49.5	26.5	26.0	16.0	36	27	499
◇ TEV-38SR 3.2	708.3702.953.30	420	1 1/2	52x2.0	74.0	41.0	39.0	22.0	60	50	1722

Baumaße sind Ungefährmaße bei angezogener Überwurfmutter.

Sizes are approximate dimensions at tightened nut.

Las medidas son aproximadas con la tuerca de unión apretada.

D1=Rohr außen-Ø
 M1=metrisches Anschlußgewinde
 ◇=entspricht Reihe nach DIN 2353

D1=tube outside diameter
 M1=metric connecting thread
 ◇=according to series DIN 2353

D1=Ø exterior del tubo
 M1=rosca métrica conexión
 ◇=según serie DIN 2353

T-Einschraubstutzen

Abdichtung im Kegengewinde Form C nach DIN 3852-2

Male adaptor T connectors

taper thread sealing form C acc. DIN 3852-2

Cuerpos para roscar T

cierre hermético con rosca cónica forma C según DIN 3852-2

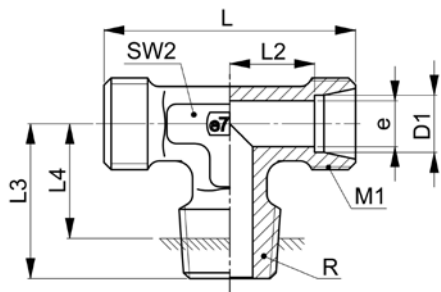

XTEV-..LRK/SRK

Type-D1 R	Mat.-Nr.	PN	R	M1	L	L2	L3	L4	SW2	e	g/Stk
R=Rohrgewinde (kegelig)		R=BSP thread (tapered)									
											R=rosca para tubos (cónica)
◇ XTEV-06LRK 1.8	706.3701.100.20	315	1/8	12x1.5	38.0	12.0	20.0	15.0	12	4.0	32
XTEV-06LRK 1.4	706.3701.110.20	315	1/4	12x1.5	38.0	12.0	20.0	12.0	12	4.0	43
◇ XTEV-08LRK 1.4	706.3701.170.20	315	1/4	14x1.5	42.0	14.0	26.0	18.0	12	6.0	44
◇ XTEV-10LRK 1.4	706.3701.270.20	315	1/4	16x1.5	44.0	15.0	27.0	19.0	14	8.0	52
XTEV-10LRK 3.8	706.3701.280.20	315	3/8	16x1.5	44.0	15.0	27.0	19.0	14	8.0	60
◇ XTEV-12LRK 3.8	706.3701.390.20	315	3/8	18x1.5	48.0	17.0	28.0	20.0	17	10.0	71
XTEV-12LRK 1.2	706.3701.400.20	315	1/2	18x1.5	56.0	21.0	28.0	18.0	17	10.0	107
◇ XTEV-15LRK 1.2	706.3701.534.20	315	1/2	22x1.5	56.0	21.0	34.0	24.0	19	12.0	132
◇ XTEV-18LRK 1.2	706.3701.646.20	315	1/2	26x1.5	62.0	23.5	36.0	26.0	24	15.0	194
◇ XTEV-06SRK 1.4	706.3701.110.30	400	1/4	14x1.5	46.0	16.0	26.0	18.0	12	4.0	58
◇ XTEV-08SRK 1.4	706.3701.170.30	400	1/4	16x1.5	48.0	17.0	27.0	19.0	14	5.0	72
◇ XTEV-10SRK 3.8	706.3701.280.30	400	3/8	18x1.5	50.0	17.5	28.0	20.0	17	7.0	94
◇ XTEV-12SRK 3.8	706.3701.390.30	400	3/8	20x1.5	58.0	21.5	28.0	20.0	17	8.0	118
XTEV-14SRK 1.2	706.3701.504.30	400	1/2	22x1.5	60.0	22.0	32.0	22.0	19	10.0	153
◇ XTEV-16SRK 1.2	706.3701.566.30	400	1/2	24x1.5	66.0	24.5	32.0	22.0	24	12.0	193

Druckangaben gelten in Verbindung mit zylindrischem Innengewinde.

Pressure information applies in connection with parallel female thread.

Datos de presión válidos en combinación con roscas interiores cilíndricas.

Einbaumaß L4 ist abhängig von den Masstoleranzen des Gegenstückes.

Installation size L4 is dependent on the size tolerances of the counterpart.

Distancia de referencia L4 según las tolerancias dimensionales de la contrapieza.

D1=Rohr außen-Ø
 M1=metrisches Anschlußgewinde
 e=kleinster Innen-Ø
 ◇=entspricht Reihe nach DIN 2353

D1=tube outside diameter
 M1=metric connecting thread
 e=minimum inside diameter
 ◇=according to series DIN 2353

D1=Ø exterior del tubo
 M1=rosca métrica conexión
 e=Ø interior mínimo
 ◇=según serie DIN 2353

T-Einschraubverschraubungen

Abdichtung im Kegelgewinde Form C nach DIN 3852-2

Male adaptor T fittings

taper thread sealing form C acc. DIN 3852-2

Racores para roscar T

cierre hermético con rosca cónica forma C según DIN 3852-2

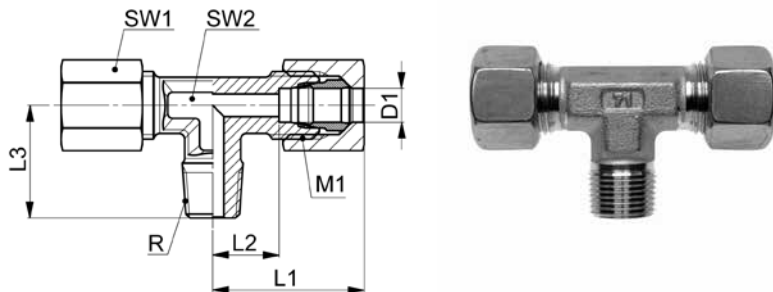

TEV-..LRK/SRK

Type-D1 R	Mat.-Nr.	PN	R	M1	L1	L2	L3	SW1	SW2	g/Stk
R=Rohrgewinde (kegelig)		R=BSP thread (tapered)					R=rosca para tubos (cónica)			
◇ TEV-06LRK 1.8	708.3701.100.20	315	1/8	12x1.5	27.0	12.0	20.0	14	12	52
TEV-06LRK 1.4	708.3701.110.20	315	1/4	12x1.5	27.0	12.0	20.0	14	12	56
◇ TEV-08LRK 1.4	708.3701.170.20	315	1/4	14x1.5	29.0	14.0	26.0	17	12	72
◇ TEV-10LRK 1.4	708.3701.270.20	315	1/4	16x1.5	30.5	15.0	27.0	19	14	76
TEV-10LRK 3.8	708.3701.280.20	315	3/8	16x1.5	30.5	15.0	27.0	19	14	82
◇ TEV-12LRK 3.8	708.3701.390.20	315	3/8	18x1.5	32.5	17.0	28.0	22	17	102
TEV-12LRK 1.2	708.3701.400.20	315	1/2	18x1.5	37.0	21.0	28.0	22	17	138
◇ TEV-15LRK 1.2	708.3701.534.20	315	1/2	22x1.5	37.0	21.0	34.0	27	19	201
◇ TEV-18LRK 1.2	708.3701.646.20	315	1/2	26x1.5	40.5	23.5	36.0	32	24	296
◇ TEV-06SRK 1.4	708.3701.110.30	400	1/4	14x1.5	31.0	16.0	26.0	17	12	100
◇ TEV-08SRK 1.4	708.3701.170.30	400	1/4	16x1.5	32.0	17.0	27.0	19	14	113
◇ TEV-10SRK 3.8	708.3701.280.30	400	3/8	18x1.5	34.5	17.5	28.0	22	17	135
◇ TEV-12SRK 3.8	708.3701.390.30	400	3/8	20x1.5	38.5	21.5	28.0	24	17	159
TEV-14SRK 1.2	708.3701.504.30	400	1/2	22x1.5	40.5	22.0	32.0	27	19	238
◇ TEV-16SRK 1.2	708.3701.566.30	400	1/2	24x1.5	44.0	24.5	32.0	30	24	339

Druckangaben gelten in Verbindung mit zylindrischem Innengewinde.

Pressure information applies in connection with parallel female thread.

Datos de presión válidos en combinación con roscas interiores cilíndricas.

Baumaße sind Ungefährmaße bei angezogener Überwurfmutter.

Sizes are approximate dimensions at tightened nut.

Las medidas son aproximadas con la tuerca de unión apretada.

D1=Rohr außen-Ø
M1=metrisches Anschlußgewinde
◇=entspricht Reihe nach DIN 2353

D1=tube outside diameter
M1=metric connecting thread
◇=according to series DIN 2353

D1=Ø exterior del tubo
M1=rosca métrica conexión
◇=según serie DIN 2353

T-Einschraubstutzen NPT

Male adaptor T connectors NPT

Cuerpos para roscar T NPT

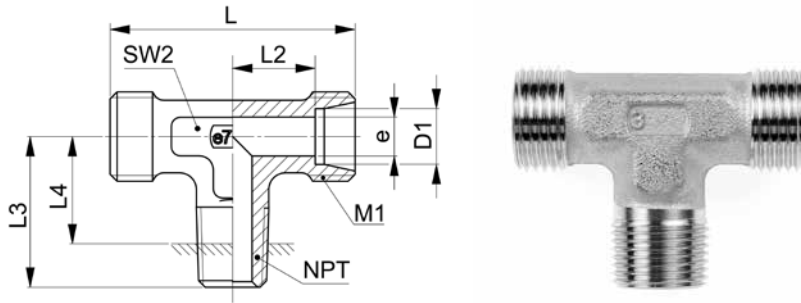

XTEV-..LNPT/SNPT

Type -D1 NPT	Mat.-Nr.	PN	NPT	M1	L	L2	L3	L4	SW2	e	g/Stk
NPT=Einschraubgewinde NPT		NPT=tapered male adaptor thread NPT				NPT=rosca de conexión cónica NPT					
XTEV-06LNPT 1.8	706.3704.100.20	500	1/8	12x1.5	38.0	12.0	20.0	13.5	12	4.0	32
XTEV-10LNPT 1.4	706.3704.270.20	500	1/4	16x1.5	44.0	15.0	27.0	17.0	14	7.0	52
XTEV-12LNPT 3.8	706.3704.390.20	400	3/8	18x1.5	48.0	17.0	28.0	18.0	17	9.0	69
XTEV-15LNPT 1.2	706.3704.534.20	400	1/2	22x1.5	56.0	21.0	34.0	20.0	19	12.0	121
XTEV-18LNPT 1.2	706.3704.646.20	400	1/2	26x1.5	62.0	23.5	36.0	22.0	24	14.0	151
XTEV-22LNPT 3.4	706.3704.768.20	250	3/4	30x2.0	70.0	27.5	42.0	28.0	27	18.0	235
XTEV-06SNPT 1.4	706.3704.110.30	800	1/4	14x1.5	46.0	16.0	26.0	16.0	12	4.0	55
XTEV-12SNPT 3.8	706.3704.390.30	630	3/8	20x1.5	58.0	21.5	28.0	18.0	17	8.0	115
XTEV-16SNPT 1.2	706.3704.566.30	630	1/2	24x1.5	66.0	24.5	36.0	22.0	24	12.0	187

D1=Rohr außen-Ø
M1=metrisches Anschlußgewinde
e=kleinster Innen-Ø

D1=tube outside diameter
M1=metric connecting thread
e=minimum inside diameter

D1=Ø exterior del tubo
M1=rosca métrica conexión
e=Ø interior mínimo

T-Einschraubverschraubungen NPT
Male adaptor T fittings NPT
Racores para roscar T NPT

10

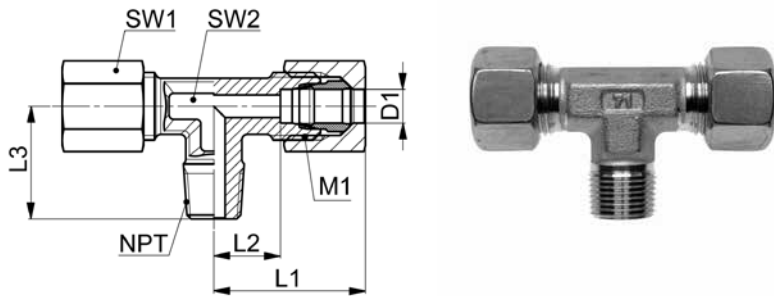

TEV-..LNPT/SNPT

Type-D1 NPT	Mat.-Nr.	PN	NPT	M1	L1	L2	L3	SW1	SW2	g/Stk
NPT=Einschraubgewinde NPT		NPT=tapered male adaptor thread NPT			NPT=rosca de conexión cónica NPT					
TEV-06LNPT 1.8	708.3704.100.20	500	1/8	12x1.5	27.0	12.0	20.0	14	12	50
TEV-10LNPT 1.4	708.3704.270.20	500	1/4	16x1.5	30.5	15.0	27.0	19	14	90
TEV-12LNPT 3.8	708.3704.390.20	400	3/8	18x1.5	32.5	17.0	28.0	22	17	129
TEV-15LNPT 1.2	708.3704.534.20	400	1/2	22x1.5	37.0	21.0	34.0	27	19	215
TEV-18LNPT 1.2	708.3704.646.20	400	1/2	26x1.5	40.5	23.5	36.0	32	24	295
TEV-22LNPT 3.4	708.3704.768.20	250	3/4	30x2.0	44.5	27.5	42.0	36	27	433
TEV-06SNPT 1.4	708.3704.110.30	800	1/4	14x1.5	31.0	16.0	26.0	17	12	94
TEV-12SNPT 3.8	708.3704.390.30	630	3/8	20x1.5	38.5	21.5	28.0	24	17	184
TEV-16SNPT 1.2	708.3704.566.30	630	1/2	24x1.5	44.0	24.5	36.0	30	24	327

Baumaße sind Ungefährmaße bei angezogener Überwurfmutter.

Sizes are approximate dimensions at tightened nut.

Las medidas son aproximadas con la tuerca de unión apretada.

D1=Rohr außen-Ø
 M1=metrisches Anschlußgewinde

D1=tube outside diameter
 M1=metric connecting thread

D1=Ø exterior del tubo
 M1=rosca métrica conexión

L-Einschraubstutzen

Abdichtung durch Dichtkante Form B nach DIN 3852-2

Male adaptor L connectors

sealing edge form B acc. DIN 3852-2

Cuerpos para roscar L

cierre hermético mediante borde de obturación forma B según DIN 3852-2

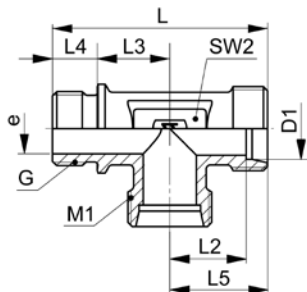

XLEV-..LR

Type-D1 G	Mat.-Nr.	PN	G	M1	L	L2	L3	L4	L5	SW2	e	g/Stk
G=Rohrgewinde (zylindrisch)		G=BSP thread (parallel)					G=rosca de conexión (cilíndrica)					
◇ XLEV-22LR 3.4	706.3712.708.20	250	3/4	30x2.0	77.0	27.5	26.0	16.0	35.0	27	18.0	235
◇ XLEV-28LR 1.1	706.3712.850.20	250	1	36x2.0	86.0	30.5	30.0	18.0	38.0	36	23.0	405
◇ XLEV-42LR 3.2	706.3712.992.20	250	1 1/2	52x2.0	112.0	40.0	39.0	22.0	51.0	50	36.0	877

D1=Rohraußen-Ø
 M1=metrisches Anschlußgewinde
 e=kleinster Innen-Ø
 ◇=entspricht Reihe nach DIN 2353

D1=tube outside diameter
 M1=metric connecting thread
 e=minimum inside diameter
 ◇=according to series DIN 2353

D1=Ø exterior del tubo
 M1=rosca métrica conexión
 e=Ø interior mínimo
 ◇=según serie DIN 2353

L-Einschraubverschraubungen

Abdichtung durch Dichtkante Form B nach DIN 3852-2

Male adaptor L fittings

sealing edge form B acc. DIN 3852-2

Racores para roscar L

cierre hermético mediante borde de obturación forma B según DIN 3852-2

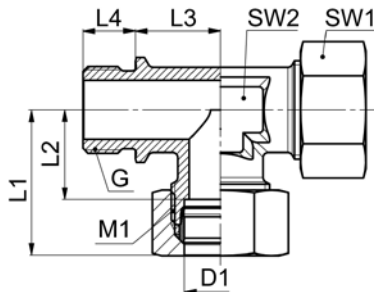

LEV-..LR

Type-D1 G	Mat.-Nr.	PN	G	M1	L1	L2	L3	L4	SW1	SW2	g/Stk
G=Rohrgewinde (zylindrisch)		G=BSP thread (parallel)						G=rosca de conexión (cilíndrica)			
◇ LEV-22LR 3.4	708.3712.708.20	250	3/4	30x2.0	44.0	27.5	26.0	16.0	36	27	371
◇ LEV-28LR 1.1	708.3712.850.20	250	1	36x2.0	47.0	30.5	30.0	18.0	41	36	544
◇ LEV-42LR 3.2	708.3712.992.20	250	1 1/2	52x2.0	63.0	40.0	39.0	22.0	60	50	1240

Baumaße sind Ungefährmaße bei angezogener Überwurfmutter.

Sizes are approximate dimensions at tightened nut.

Las medidas son aproximadas con la tuerca de unión apretada.

D1=Rohr außen-Ø
M1=metrisches Anschlußgewinde
◇=entspricht Reihe nach DIN 2353

D1=tube outside diameter
M1=metric connecting thread
◇=according to series DIN 2353

D1=Ø exterior del tubo
M1=rosca métrica conexión
◇=según serie DIN 2353

L-Einschraubstutzen

Abdichtung im Kegelfgewinde Form C nach DIN 3852-2

Male adaptor L connectors

taper thread sealing form C acc. DIN 3852-2

Cuerpos para roscar L

cierre hermético con rosca cónica forma C según DIN 3852-2

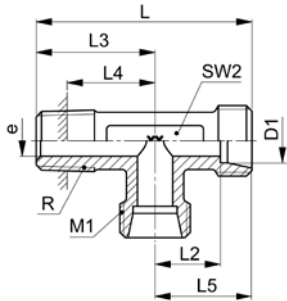

XLEV-..LRK/SRK

Type-D1 R	Mat.-Nr.	PN	R	M1	L	L2	L3	L4	L5	SW2	e	g/Stk
R=Rohrgewinde (kegelig)		R=BSP thread (tapered)					R=rosca para tubos (cónica)					
◇ XLEV-06LRK 1.8	706.3711.100.20	315	1/8	12x1.5	39.0	12.0	20.0	15.0	19.0	12	4.0	32
◇ XLEV-08LRK 1.4	706.3711.170.20	315	1/4	14x1.5	47.0	14.0	26.0	18.0	21.0	12	6.0	44
◇ XLEV-10LRK 1.4	706.3711.270.20	315	1/4	16x1.5	49.0	15.0	27.0	19.0	22.0	14	7.0	52
◇ XLEV-12LRK 3.8	706.3711.390.20	315	3/8	18x1.5	52.0	17.0	28.0	20.0	24.0	17	9.0	72
◇ XLEV-15LRK 1.2	706.3711.534.20	315	1/2	22x1.5	62.0	21.0	34.0	24.0	28.0	19	11.0	134
◇ XLEV-18LRK 1.2	706.3711.646.20	315	1/2	26x1.5	67.0	23.5	36.0	26.0	31.0	24	14.0	173
◇ XLEV-06SRK 1.4	706.3711.111.30	400	1/4	14x1.5	49.0	16.0	26.0	18.0	23.0	12	4.0	58
◇ XLEV-08SRK 1.4	706.3711.170.30	400	1/4	16x1.5	51.0	17.0	27.0	19.0	24.0	14	5.0	73
◇ XLEV-10SRK 3.8	706.3711.280.30	400	3/8	18x1.5	53.0	17.5	28.0	20.0	25.0	17	7.0	91
◇ XLEV-12SRK 3.8	706.3711.390.30	400	3/8	20x1.5	57.0	21.5	28.0	20.0	29.0	17	8.0	119
◇ XLEV-14SRK 1.2	706.3711.504.30	400	1/2	22x1.5	62.0	22.0	32.0	22.0	30.0	19	10.0	155
◇ XLEV-16SRK 1.2	706.3711.566.30	400	1/2	24x1.5	65.0	24.5	32.0	22.0	33.0	24	12.0	195

Druckangaben gelten in Verbindung mit zylindrischem Innengewinde.

Pressure information applies in connection with parallel female thread.

Datos de presión válidos en combinación con roscas interiores cilíndricas.

Einbaumaß L4 ist abhängig von den Masstoleranzen des Gegenstückes.

Installation size L4 is dependent on the size tolerances of the counterpart.

Distancia de referencia L4 según las tolerancias dimensionales de la contrapieza.

D1=Rohr außen-Ø
 M1=metrisches Anschlußgewinde
 e=kleinster Innen-Ø
 ◇=entspricht Reihe nach DIN 2353

D1=tube outside diameter
 M1=metric connecting thread
 e=minimum inside diameter
 ◇=according to series DIN 2353

D1=Ø exterior del tubo
 M1=rosca métrica conexión
 e=Ø interior mínimo
 ◇=según serie DIN 2353

L-Einschraubverschraubungen

Abdichtung im Kegengewinde Form C nach DIN 3852-2

Male adaptor L fittings

taper thread sealing form C acc. DIN 3852-2

Racores para roscar L

cierre hermético con rosca cónica forma C según DIN 3852-2

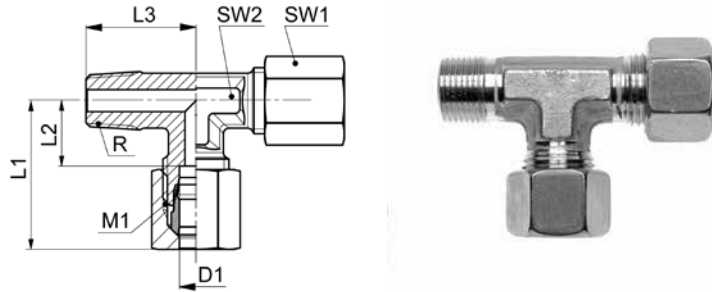

LEV-..LRK/SRK

Type-D1 R	Mat.-Nr.	PN	R	M1	L1	L2	L3	SW1	SW2	g/Stk
R=Rohrgewinde (kegelig)		R=BSP thread (tapered)					R=rosca para tubos (cónica)			
◇ LEV-06LRK 1.8	708.3711.100.20	315	1/8	12x1.5	27.0	12.0	20.0	14	12	53
◇ LEV-08LRK 1.4	708.3711.170.20	315	1/4	14x1.5	29.0	14.0	26.0	17	12	73
◇ LEV-10LRK 1.4	708.3711.270.20	315	1/4	16x1.5	30.0	15.0	27.0	19	14	100
◇ LEV-12LRK 3.8	708.3711.390.20	315	3/8	18x1.5	32.0	17.0	28.0	22	17	120
◇ LEV-15LRK 1.2	708.3711.534.20	315	1/2	22x1.5	36.0	21.0	34.0	27	19	167
◇ LEV-18LRK 1.2	708.3711.646.20	315	1/2	26x1.5	40.0	23.5	36.0	32	24	296
◇ LEV-06SRK 1.4	708.3711.111.30	400	1/4	14x1.5	31.0	16.0	26.0	17	12	97
◇ LEV-08SRK 1.4	708.3711.170.30	400	1/4	16x1.5	32.0	17.0	27.0	19	14	128
◇ LEV-10SRK 3.8	708.3711.280.30	400	3/8	18x1.5	34.0	17.5	28.0	22	17	172
◇ LEV-12SRK 3.8	708.3711.390.30	400	3/8	20x1.5	38.0	21.5	28.0	24	17	244
◇ LEV-14SRK 1.2	708.3711.504.30	400	1/2	22x1.5	41.0	22.0	32.0	27	19	245
◇ LEV-16SRK 1.2	708.3711.566.30	400	1/2	24x1.5	43.0	24.5	32.0	30	24	320

Druckangaben gelten in Verbindung mit zylindrischem Innengewinde.

Pressure information applies in connection with parallel female thread.

Datos de presión válidos en combinación con roscas interiores cilíndricas.

Baumaße sind Ungefährmaße bei angezogener Überwurfmutter.

Sizes are approximate dimensions at tightened nut.

Las medidas son aproximadas con la tuerca de unión apretada.

D1=Rohr außen-Ø
M1=metrisches Anschlußgewinde
◇=entspricht Reihe nach DIN 2353

D1=tube outside diameter
M1=metric connecting thread
◇=according to series DIN 2353

D1=Ø exterior del tubo
M1=rosca métrica conexión
◇=según serie DIN 2353

L-Einschraubstutzen NPT

Male adaptor L connectors NPT

Cuerpos para roscar L NPT

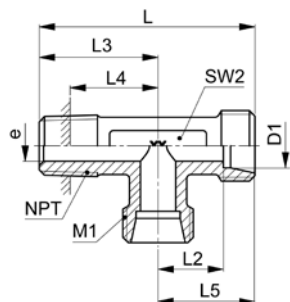

XLEV-..LNPT/SNPT

Type -D1 NPT	Mat.-Nr.	PN	NPT	M1	L	L2	L3	L4	L5	SW2	e	g/Stk	
NPT=Einschraubgewinde NPT		NPT=tapered male adaptor thread NPT					NPT=rosca de conexión cónica NPT						
XLEV-08LNPT 1.4	706.3755.170.20	500	1/4	14x1.5	47.0	14.0	26.0	16.0	21.0	12	6.0	44	
XLEV-15LNPT 1.2	706.3755.534.20	400	1/2	22x1.5	62.0	21.0	34.0	20.0	28.0	19	12.0	126	
XLEV-22LNPT 3.4	706.3755.768.20	250	3/4	30x2.0	77.0	27.5	42.0	28.0	35.0	27	18.0	246	
XLEV-06SNPT 1.4	706.3755.110.30	800	1/4	14x1.5	49.0	16.0	26.0	16.0	23.0	12	4.0	58	
XLEV-08SNPT 1.4	706.3755.170.30	800	1/4	16x1.5	51.0	17.0	27.0	17.0	24.0	14	5.0	73	
XLEV-16SNPT 1.2	706.3755.566.30	630	1/2	24x1.5	65.0	24.5	32.0	18.0	33.0	24	12.0	188	

D1=Rohr außen-Ø
M1=metrisches Anschlußgewinde
e=kleinster Innen-Ø

D1=tube outside diameter
M1=metric connecting thread
e=minimum inside diameter

D1=Ø exterior del tubo
M1=rosca métrica conexión
e=Ø interior mínimo

L-Einschraubverschraubungen NPT
Male adaptor L fittings NPT
Racores para roscar L NPT

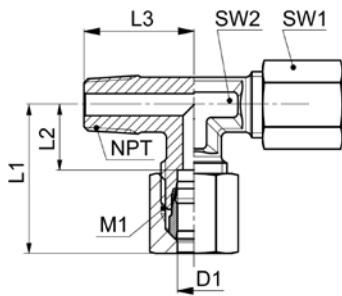

10

LEV-..LNPT/SNPT

Type-D1 NPT	Mat.-Nr.	PN	NPT	M1	L1	L2	L3	SW1	SW2	g/Stk
NPT=Einschraubgewinde NPT		NPT=tapered male adaptor thread NPT			NPT=rosca de conexión cónica NPT					
LEV-08LNPT 1.4	708.3755.170.20	500	1/4	14x1.5	29.0	14.0	26.0	17	12	77
LEV-15LNPT 1.2	708.3755.534.20	400	1/2	22x1.5	36.0	21.0	34.0	27	19	191
LEV-22LNPT 3.4	708.3755.768.20	250	3/4	30x2.0	44.0	27.5	42.0	36	27	347
LEV-06SNPT 1.4	708.3755.110.30	800	1/4	14x1.5	31.0	16.0	26.0	17	12	103
LEV-08SNPT 1.4	708.3755.170.30	800	1/4	16x1.5	32.0	17.0	27.0	19	14	133
LEV-16SNPT 1.2	708.3755.566.30	630	1/2	24x1.5	43.0	24.5	32.0	30	24	320

Baumaße sind Ungefährmaße bei angezogener Überwurfmutter.

Sizes are approximate dimensions at tightened nut.

Las medidas son aproximadas con la tuerca de unión apretada.

D1=Rohr außen-Ø
M1=metrisches Anschlußgewinde

D1=tube outside diameter
M1=metric connecting thread

D1=Ø exterior del tubo
M1=rosca métrica conexión

Gerade Thermoelementstutzen

Abdichtung durch Dichtkante Form B nach DIN 3852-2

Straight connectors for temperature sensors

sealing edge form B acc. DIN 3852-2

Cuerpos para roscar rectos de termosonda

cierre hermético mediante borde de obturación forma B según DIN 3852-2

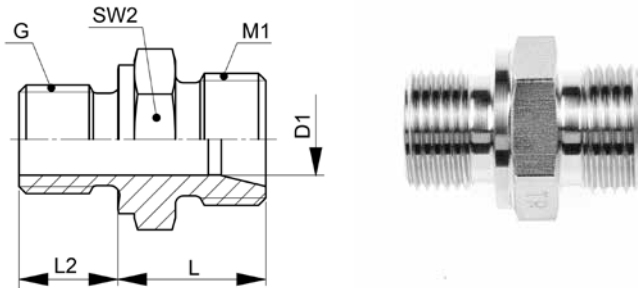

XGEV-..LR D

Type-D1 G	Mat.-Nr.	PN	G	M1	L	L2	SW2	g/Stk
G=Rohrgewinde (zylindrisch)		G=BSP thread (parallel)			G=rosca de conexión (cilíndrica)			
XGEV-06LR 1.4 D	706.1151.110.20	500	1/4	12x1.5	17.0	12.0	19	27
XGEV-08LR 3.8 D	706.1151.180.20	500	3/8	14x1.5	19.5	12.0	22	46
XGEV-10LR 1.2 D	706.1151.285.20	500	1/2	16x1.5	21.0	14.0	27	74
XGEV-12LR 1.2 D	706.1151.400.20	400	1/2	18x1.5	20.0	14.0	27	64
XGEV-12LR 3.4 D	706.1151.405.20	400	3/4	18x1.5	21.0	16.0	32	115

D1=Rohr außen-Ø
M1=metrisches Anschlußgewinde

D1=tube outside diameter
M1=metric connecting thread

D1=Ø exterior del tubo
M1=rosca métrica conexión

Gerade Thermoelementverschraubungen

Abdichtung durch Dichtkante Form B nach DIN 3852-2

Straight fittings for temperature sensors

sealing edge form B acc. DIN 3852-2

Racores de termosonda

cierre hermético mediante borde de obturación forma B según DIN 3852-2

10

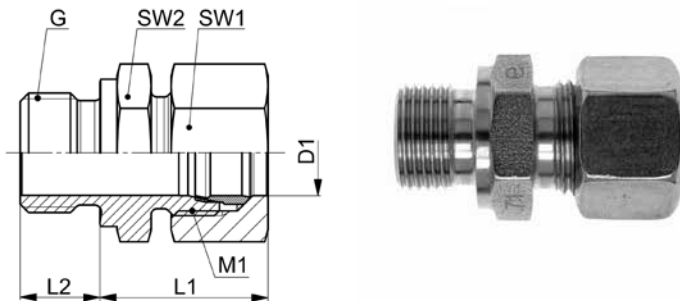

GEV-..LR D

Type-D1 G	Mat.-Nr.	PN	G	M1	L1	L2	SW1	SW2	g/Stk
G=Rohrgewinde (zylindrisch)		G=BSP thread (parallel)				G=rosca de conexión (cilíndrica)			
GEV-06LR 1.4 D	708.1151.110.20	500	1/4	12x1.5	25.0	12.0	14	19	37
GEV-08LR 3.8 D	708.1151.180.20	500	3/8	14x1.5	27.5	12.0	17	22	58
GEV-10LR 1.2 D	708.1151.285.20	500	1/2	16x1.5	29.0	14.0	19	27	90
GEV-12LR 1.2 D	708.1151.400.20	400	1/2	18x1.5	28.0	14.0	22	27	87
GEV-12LR 3.4 D	708.1151.405.20	400	3/4	18x1.5	29.0	16.0	22	32	138

Baumaße sind Ungefährmaße bei angezogener Überwurfmutter.

Sizes are approximate dimensions at tightened nut.

Las medidas son aproximadas con la tuerca de unión apretada.

Auf Anfrage auch mit PTFE Klemmring möglich.

Available also with PTFE clamping ring on request.

También disponible, bajo demanda, con anillo de apriete de PTFE.

D1=Rohr außen-Ø
M1=metrisches Anschlußgewinde

D1=tube outside diameter
M1=metric connecting thread

D1=Ø exterior del tubo
M1=rosca métrica conexión

PTFE-Klemmringe

für Thermoelementverschraubungen

PTFE sealing rings

for straight fittings for temperature sensors

Anillos de apriete de PTFE

para racores de termosonda

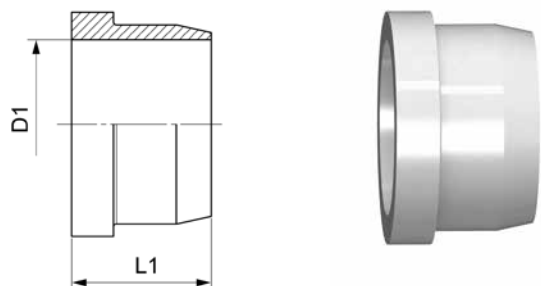

PTFE-KLEMMRING

Type-D1	Mat.-Nr.	PN	L1	g/Stk
PTFE-R-06L/S	706.0016.060.13	10	9.0	1
PTFE-R-08L/S	706.0016.080.13	10	9.0	1
PTFE-R-10L/S	706.0016.100.13	10	10.0	1
PTFE-R-12L/S	706.0016.120.13	10	10.0	1

Gerade Einschraubstutzen mit Dichtkegel und O-Ring

Abdichtung durch Profildichtring Form E nach ISO 1179-2

Straight male adaptor unions with taper and O-ring

profile sealing ring form E acc. ISO 1179-2

Racores para roscar rectos con junta cónica y junta tórica

cierre hermético mediante junta con perfil forma E según ISO 1179-2

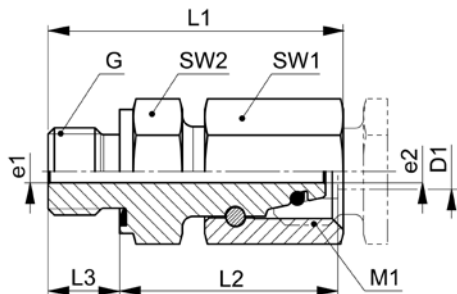

EGKO-..LR WD/SR WD

Type-D1 G	Mat.-Nr.	PN	G	M1	L1	L2	L3	SW1	SW2	e1	e2	g/Stk
G=Rohrgewinde (zylindrisch)		G=BSP thread (parallel)			G=rosca de conexión (cilíndrica)							
EGKO-06LR 1.8 WD	708.1670.100.21	315	1/8	12x1.5	33.0	24.5	8.0	14	14	2.5	2.5	36
EGKO-08LR 1.4 WD	708.1670.170.21	315	1/4	14x1.5	42.0	29.5	12.0	17	19	4.0	4.0	57
EGKO-08LR 3.8 WD	708.1670.180.21	315	3/8	14x1.5	42.0	29.5	12.0	17	22	9.0	4.0	65
EGKO-10LR 1.4 WD	708.1670.270.21	315	1/4	16x1.5	40.5	27.5	12.0	19	19	6.0	6.0	58
EGKO-10LR 3.8 WD	708.1670.280.21	315	3/8	16x1.5	42.0	29.0	12.0	19	22	6.0	6.0	78
EGKO-12LR 1.4 WD	708.1670.380.21	315	1/4	18x1.5	40.0	27.5	12.0	22	19	7.0	7.0	68
EGKO-12LR 3.8 WD	708.1670.390.21	315	3/8	18x1.5	46.5	34.0	12.0	22	22	8.0	8.0	95
EGKO-12LR 1.2 WD	708.1670.400.21	315	1/2	18x1.5	44.0	29.5	14.0	22	27	8.0	8.0	110
EGKO-15LR 1.2 WD	708.1670.534.21	315	1/2	22x1.5	48.0	32.0	14.0	27	27	10.0	10.0	144
EGKO-18LR 1.2 WD	708.1670.646.21	315	1/2	26x1.5	45.0	31.5	14.0	32	27	13.0	13.0	152
EGKO-18LR 3.4 WD	708.1670.648.21	315	3/4	26x1.5	45.0	29.5	16.0	32	32	13.0	13.0	190
EGKO-22LR 1.2 WD	708.1670.764.21	160	1/2	30x2.0	50.5	34.5	14.0	36	27	14.0	14.0	206
EGKO-22LR 3.4 WD	708.1670.768.21	160	3/4	30x2.0	50.5	32.5	16.0	36	32	17.0	17.0	202
EGKO-22LR 1.1 WD	708.1670.770.21	160	1	30x2.0	53.5	33.5	18.0	36	41	22.0	17.0	297
EGKO-28LR 1.1 WD	708.1670.850.21	160	1	36x2.0	56.0	35.0	18.0	41	41	22.0	22.0	356
EGKO-35LR 5.4 WD	708.1670.944.21	160	1 1/4	45x2.0	63.5	42.5	20.0	50	50	28.0	28.0	507
EGKO-42LR 3.2 WD	708.1670.992.21	160	1 1/2	52x2.0	69.5	46.5	22.0	60	55	34.0	34.0	664
EGKO-06SR 1.4 WD	708.1670.110.31	630	1/4	14x1.5	39.5	27.0	12.0	17	19	2.5	2.5	56
EGKO-08SR 1.4 WD	708.1670.170.31	630	1/4	16x1.5	42.0	29.5	12.0	19	19	4.0	4.0	62
EGKO-10SR 1.4 WD	708.1670.270.31	630	1/4	18x1.5	38.0	26.0	12.0	22	19	6.0	6.0	68
EGKO-10SR 3.8 WD	708.1670.280.31	630	3/8	18x1.5	44.0	32.0	12.0	22	22	6.0	6.0	92
EGKO-12SR 1.4 WD	708.1670.380.31	630	1/4	20x1.5	45.0	33.5	12.0	24	19	6.0	8.0	97
EGKO-12SR 3.8 WD	708.1670.390.31	630	3/8	20x1.5	45.5	34.0	12.0	24	22	8.0	8.0	110
EGKO-12SR 1.2 WD	708.1670.400.31	630	1/2	20x1.5	58.5	35.0	14.0	24	27	8.0	8.0	153
EGKO-14SR 1.2 WD	708.1670.504.31	630	1/2	22x1.5	51.5	36.5	14.0	27	27	8.0	8.0	170
EGKO-16SR 1.2 WD	708.1670.566.31	400	1/2	24x1.5	51.5	37.0	14.0	30	27	11.0	11.0	230
EGKO-20SR 1.2 WD	708.1670.706.31	400	1/2	30x2.0	49.5	35.0	14.0	36	27	14.0	14.0	242
EGKO-20SR 3.4 WD	708.1670.704.31	400	3/4	30x2.0	59.5	43.0	16.0	36	32	14.0	14.0	286
EGKO-25SR 1.1 WD	708.1670.810.31	400	1	36x2.0	66.0	48.0	18.0	46	41	18.0	18.0	494
EGKO-30SR 5.4 WD	708.1670.902.31	400	1 1/4	42x2.0	68.5	50.5	20.0	50	50	23.0	23.0	674
EGKO-38SR 3.2 WD	708.1670.953.31	315	1 1/2	52x2.0	78.0	59.5	22.0	60	55	30.0	30.0	931

Baumaße sind Ungefährmaße bei angezogener Überwurfmutter.

Dichtungsmaterial: FKM (andere Werkstoffe auf Anfrage)

Sizes are approximate dimensions at tightened nut.

Sealing material: FKM (other materials on request)

Las medidas son aproximadas con la tuerca de unión apretada.

Material de junta tórica: FKM (otros materiales bajo demanda)

ISO 8434-1-SWOSDS

D1=Rohr außen-Ø
M1=metrisches Anschlußgewinde
e1/e2=kleinste Innen-Ø

D1=tube outside diameter
M1=metric connecting thread
e1/e2=minimum inside diameters

D1=Ø exterior del tubo
M1=rosca métrica conexión
e1/e2=Ø interiores mínimos

Gerade Einschraubstutzen mit Dichtkegel und O-Ring

Abdichtung durch Profildichtring Form E nach ISO 1179-2

Straight male adaptor unions with taper and O-ring

profile sealing ring form E acc. ISO 1179-2

Racores para roscar rectos con junta cónica y junta tórica

cierre hermético mediante junta con perfil forma E según ISO 1179-2

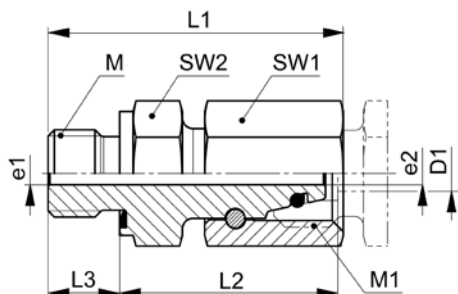

EGKO-..LM WD/SM WD

Type-D1 M	Mat.-Nr.	PN	M	M1	L1	L2	L3	SW1	SW2	e1	e2	g/Stk
EGKO-06LM 10x1,0 WD	708.1671.180.21	315	10x1.0	12x1.5	33.0	24.5	8.0	14	14	2.5	2.5	36
EGKO-08LM 12x1,5 WD	708.1671.240.21	315	12x1.5	14x1.5	39.0	26.5	12.0	17	17	4.0	4.0	57
EGKO-10LM 14x1,5 WD	708.1671.280.21	315	14x1.5	16x1.5	40.5	27.5	12.0	19	19	6.0	6.0	58
EGKO-12LM 16x1,5 WD	708.1671.330.21	315	16x1.5	18x1.5	43.0	30.5	12.0	22	22	8.0	8.0	75
EGKO-15LM 18x1,5 WD	708.1671.390.21	315	18x1.5	22x1.5	45.5	31.5	12.0	27	24	10.0	10.0	144
EGKO-18LM 22x1,5 WD	708.1671.460.21	315	22x1.5	26x1.5	45.0	31.5	14.0	32	27	13.0	13.0	152
EGKO-22LM 26x1,5 WD	708.1671.535.21	160	26x1.5	30x2.0	50.5	32.5	16.0	36	32	17.0	17.0	202
EGKO-28LM 33x2,0 WD	708.1671.570.21	160	33x2.0	36x2.0	56.0	35.0	18.0	41	41	22.0	22.0	356
EGKO-35LM 42x2,0 WD	708.1671.600.21	160	42x2.0	45x2.0	63.5	42.5	20.0	50	50	28.0	28.0	507
EGKO-42LM 48x2,0 WD	708.1671.992.21	160	48x2.0	52x2.0	69.5	46.5	22.0	60	55	34.0	34.0	664
EGKO-06SM 12x1,5 WD	708.1671.195.31	630	12x1.5	14x1.5	39.5	27.0	12.0	17	17	2.5	2.5	56
EGKO-08SM 14x1,5 WD	708.1671.245.31	630	14x1.5	16x1.5	42.0	29.5	12.0	19	19	4.0	4.0	62
EGKO-10SM 16x1,5 WD	708.1671.285.31	630	16x1.5	18x1.5	44.0	32.0	12.0	22	22	6.0	6.0	92
EGKO-12SM 18x1,5 WD	708.1671.333.31	630	18x1.5	20x1.5	45.5	34.0	12.0	24	24	8.0	8.0	110
EGKO-14SM 20x1,5 WD	708.1671.382.31	630	20x1.5	22x1.5	51.5	36.5	14.0	27	27	8.0	8.0	170
EGKO-16SM 22x1,5 WD	708.1671.410.31	400	22x1.5	24x1.5	51.5	37.0	14.0	30	27	11.0	11.0	230
EGKO-20SM 27x2,0 WD	708.1671.506.31	400	27x2.0	30x2.0	59.5	43.0	16.0	36	32	14.0	14.0	286
EGKO-25SM 33x2,0 WD	708.1671.550.31	400	33x2.0	36x2.0	66.0	48.0	18.0	46	41	18.0	18.0	494
EGKO-30SM 42x2,0 WD	708.1671.590.31	400	42x2.0	42x2.0	68.5	50.5	20.0	50	50	23.0	23.0	674
EGKO-38SM 48x2,0 WD	708.1671.954.31	315	48x2.0	52x2.0	78.0	59.5	22.0	60	55	30.0	30.0	931

Baum Maße sind Ungefährmaße bei angezogener Überwurfmutter.

Sizes are approximate dimensions at tightened nut.

Las medidas son aproximadas con la tuerca de unión apretada.

Dichtungsmaterial: FKM (andere Werkstoffe auf Anfrage)

Sealing material: FKM (other materials on request)

Material de junta tórica: FKM (otros materiales bajo demanda)

ISO 8434-1-SWOSDS

D1=Rohr außen-Ø
M1=metrisches Anschlußgewinde
e1/e2=kleinste Innen-Ø

D1=tube outside diameter
M1=metric connecting thread
e1/e2=minimum inside diameters

D1=Ø exterior del tubo
M1=rosca métrica conexión
e1/e2=Ø interiores mínimos

Gerade Einschraubstutzen NPT mit Dichtkegel und O-Ring
Straight male adaptor unions NPT with taper and O-ring
Racores para roscar NPT rectos con junta cónica y junta tórica

10

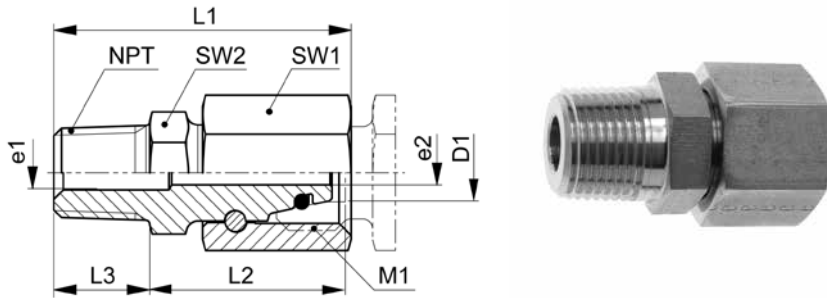

EGKO-..LNPT/SNPT

Type-D1 NPT	Mat.-Nr.	PN	NPT	M1	L1	L2	L3	SW1	SW2	e1	e2	g/Stk
NPT=Einschraubgewinde NPT		NPT=tapered male adaptor thread NPT					NPT=rosca de conexión cónica NPT					
EGKO-06LNPT 1.8	708.1672.100.21	315	1/8	12x1.5	31.0	20.5	10.0	17	11	3.5	2.5	37
EGKO-08LNPT 1.4	708.1672.170.21	315	1/4	14x1.5	38.0	23.5	14.0	17	14	6.5	4.0	69
EGKO-10LNPT 1.4	708.1672.270.21	315	1/4	16x1.5	39.0	24.0	14.0	19	14	6.0	6.0	59
EGKO-12LNPT 3.8	708.1672.390.21	315	3/8	18x1.5	40.5	23.0	17.0	22	19	8.0	8.0	102
EGKO-12LNPT 1.2	708.1672.400.21	315	1/2	18x1.5	45.5	26.0	19.0	22	22	14.0	8.0	118
EGKO-15LNPT 1.2	708.1672.534.21	315	1/2	22x1.5	51.5	30.5	19.0	27	22	14.0	10.0	159
EGKO-18LNPT 1.2	708.1672.646.21	315	1/2	26x1.5	48.5	23.0	26.0	32	27	13.0	13.0	158
EGKO-22LNPT 3.4	708.1672.768.21	160	3/4	30x2.0	54.0	32.0	20.0	36	27	19.0	17.0	216
EGKO-28LNPT 1.1	708.1672.850.21	160	1	36x2.0	64.0	36.0	25.0	41	36	22.0	22.0	383
EGKO-35LNPT 5.4	708.1672.944.21	160	1 1/4	45x2.0	66.5	39.5	26.0	50	46	28.0	28.0	505
EGKO-42LNPT 3.2	708.1672.992.21	160	1 1/2	52x2.0	69.5	42.5	26.0	60	50	34.0	34.0	770
EGKO-06SNPT 1.4	708.1672.110.31	630	1/4	14x1.5	38.0	23.5	14.0	17	14	6.5	2.5	61
EGKO-08SNPT 1.4	708.1672.170.31	630	1/4	16x1.5	38.5	24.0	14.0	19	17	6.0	4.0	62
EGKO-10SNPT 3.8	708.1672.280.31	630	3/8	18x1.5	40.5	14.5	26.0	22	19	6.0	6.0	90
EGKO-12SNPT 3.8	708.1672.390.31	630	3/8	20x1.5	41.5	14.0	14.0	24	19	8.0	8.0	95
EGKO-14SNPT 1.2	708.1672.504.31	630	1/2	22x1.5	51.5	31.5	19.0	27	22	12.0	8.0	177
EGKO-16SNPT 1.2	708.1672.566.31	400	1/2	24x1.5	51.5	32.0	19.0	30	24	11.0	11.0	236
EGKO-20SNPT 3.4	708.1672.708.31	400	3/4	30x2.0	54.5	28.0	26.0	36	27	16.0	14.0	283
EGKO-25SNPT 1.1	708.1672.810.31	400	1	36x2.0	63.5	38.5	25.0	46	36	18.0	18.0	504
EGKO-30SNPT 5.4	708.1672.902.31	400	1 1/4	42x2.0	68.0	44.0	26.0	50	46	23.0	23.0	650
EGKO-38SNPT 3.2	708.1672.953.31	315	1 1/2	52x2.0	69.5	47.0	26.0	60	50	30.0	30.0	932

Baumaße sind Ungefährmaße bei angezogener Überwurfmutter.

Sizes are approximate dimensions at tightened nut.

Las medidas son aproximadas con la tuerca de unión apretada.

Dichtungsmaterial: FKM (andere Werkstoffe auf Anfrage)

Sealing material: FKM (other materials on request)

Material de junta tórica: FKM (otros materiales bajo demanda)

D1=Rohr außen-Ø
M1=metrisches Anschlußgewinde
e1/e2=kleinste Innen-Ø

D1=tube outside diameter
M1=metric connecting thread
e1/e2=minimum inside diameters

D1=Ø exterior del tubo
M1=rosca métrica conexión
e1/e2=Ø interiores mínimos

Einschraubstutzen mit Schaft

Abdichtung durch Dichtkante Form B nach DIN 3852-2

Male adaptor standpipe connectors

sealing edge form B acc. DIN 3852-2

Cuerpos para roscar con vástago

cierre hermético con borde de obturación forma B según DIN 3852-2

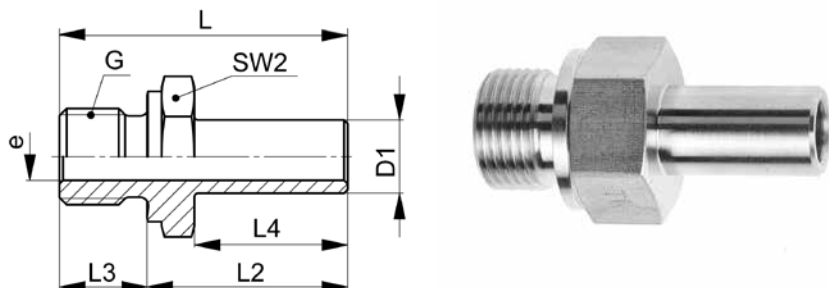

XESS-..LR/SR

Type-D1 G	Mat.-Nr.	PN	G	L	L2	L3	L4	SW2	e	g/Stk
G=Rohrgewinde (zylindrisch)		G=BSP thread (parallel)			G=rosca de conexión (cilíndrica)					
XESS-06LR/SR 1.8	706.1623.100.13	800	1/8	32.5	24.5	8.0	19.5	14	3.0	13
XESS-06LR/SR 1.4	706.1623.110.13	500	1/4	39.0	27.0	12.0	20.0	19	3.0	30
XESS-08LR/SR 1.4	706.1623.170.13	500	1/4	41.5	29.5	12.0	21.0	19	5.0	34
XESS-10LR/SR 1.4	706.1623.270.13	500	1/4	39.5	27.5	12.0	22.0	19	6.5	27
XESS-10LR/SR 3.8	706.1623.280.13	500	3/8	44.0	32.0	12.0	22.0	22	6.5	52
XESS-10LR/SR 1.2	706.1623.285.13	500	3/8	48.0	34.0	14.0	22.0	27	6.5	77
XESS-12LR/SR 1.4	706.1623.380.13	400	1/4	40.5	38.5	12.0	22.5	19	7.5	31
XESS-12LR/SR 3.8	706.1623.390.13	400	3/8	46.0	34.0	12.0	22.5	22	7.5	59
XESS-12LR/SR 1.2	706.1623.400.13	400	1/2	48.5	34.5	14.0	22.5	27	7.5	93
XESS-15LR 3.8	706.1623.532.20	400	3/8	44.0	32.0	12.0	22.0	22	10.0	55
XESS-15LR 1.2	706.1623.534.20	400	1/2	46.0	32.0	14.0	22.0	27	10.0	84
XESS-15LR 3.4	706.1623.536.20	400	3/4	50.0	34.0	16.0	22.0	32	10.0	111
XESS-18LR 1.2	706.1623.646.20	400	1/2	45.5	31.5	14.0	23.0	27	13.0	73
XESS-22LR 3.4	706.1623.768.20	250	3/4	48.5	32.5	16.0	24.5	32	16.0	115
XESS-28LR 3.4	706.1623.845.20	250	3/4	51.0	35.0	16.0	25.0	32	22.0	118
XESS-28LR 1.1	706.1623.850.20	250	1	53.0	35.0	18.0	25.0	41	22.0	186
XESS-35LR 5.4	706.1623.944.20	250	1 1/4	62.5	42.5	20.0	30.0	50	28.0	338
XESS-42LR 3.2	706.1623.992.20	250	1 1/2	68.5	46.5	22.0	30.5	55	34.0	468
XESS-14SR 1.2	706.1623.504.30	630	1/2	51.0	37.0	14.0	24.0	27	9.0	101
XESS-16SR 1.2	706.1623.566.30	630	1/2	51.0	37.0	14.0	25.0	27	10.5	97
XESS-16SR 3.4	706.1623.568.30	630	3/4	51.0	35.0	16.0	25.0	32	10.5	138
XESS-20SR 3.4	706.1623.704.30	420	3/4	59.0	43.0	16.0	30.0	32	14.0	157
XESS-25SR 1.1	706.1623.810.30	420	1	66.0	48.0	18.0	33.0	41	17.0	291
XESS-30SR 1.1	706.1623.900.30	420	1	71.0	53.0	18.0	35.5	41	22.0	290
XESS-30SR 5.4	706.1623.902.30	420	1 1/4	71.0	51.0	20.0	35.5	50	22.0	451
XESS-38SR 3.2	706.1623.953.30	420	1 1/2	82.0	60.0	22.0	40.0	55	28.0	650

D1=Rohr außen-Ø
e=kleinster Innen-Ø

D1=tube outside diameter
e=minimum inside diameter

D1=Ø exterior del tubo
e=Ø interior mínimo

Einschraubstutzen mit Schaft

schaftseitig vormontiert, Abdichtung durch Dichtkante Form B nach DIN 3852-2

Male adaptor standpipe unions

pre-assembled on standpipe side, sealing edge form B acc. DIN 3852-2

Racores para roscar con vástago

premontado en lado de vástago, cierre hermético con junta de obturación forma B según DIN 3852-2

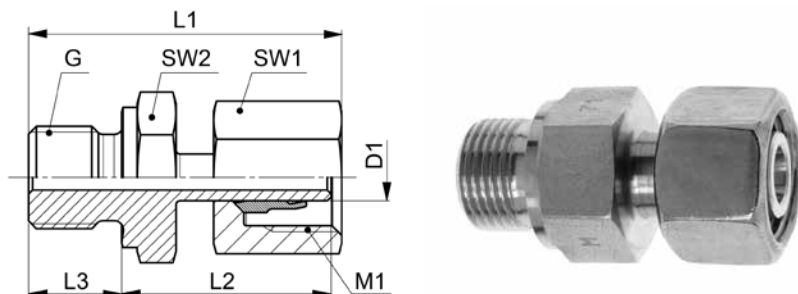

ESS-..LR/SR

Type-D1 G	Mat.-Nr.	PN	G	M1	L1	L2	L3	SW1	SW2	g/Stk
G=Rohrgewinde (zylindrisch)		G=BSP thread (parallel)								
			G=rosca de conexión (cilíndrica)							
ESS-06LR 1.8	708.1623.100.21	500	1/8	12x1.5	33.0	24.5	8.0	14	14	25
ESS-06LR 1.4	708.1623.110.21	500	1/4	12x1.5	38.0	27.0	12.0	14	19	42
ESS-08LR 1.4	708.1623.170.21	500	1/4	14x1.5	42.0	29.5	12.0	17	19	47
ESS-10LR 1.4	708.1623.270.21	500	1/4	16x1.5	40.5	27.5	12.0	19	19	49
ESS-10LR 3.8	708.1623.280.21	500	3/8	16x1.5	45.0	32.0	12.0	19	22	64
ESS-10LR 1.2	708.1623.285.21	500	1/2	16x1.5	47.5	34.0	14.0	19	27	99
ESS-12LR 1.4	708.1623.380.21	400	1/4	18x1.5	41.0	28.5	12.0	22	19	72
ESS-12LR 3.8	708.1623.390.21	400	3/8	18x1.5	46.5	34.0	12.0	22	22	74
ESS-12LR 1.2	708.1623.400.21	400	1/2	18x1.5	49.0	34.5	14.0	22	27	124
ESS-15LR 3.8	708.1623.532.21	400	3/8	22x1.5	46.0	32.0	12.0	27	22	100
ESS-15LR 1.2	708.1623.534.21	400	1/2	22x1.5	48.0	32.0	14.0	27	27	107
ESS-15LR 3.4	708.1623.536.21	400	3/4	22x1.5	50.5	34.0	16.0	27	32	161
ESS-18LR 1.2	708.1623.646.21	400	1/2	26x1.5	45.0	31.5	14.0	32	27	140
ESS-22LR 3.4	708.1623.768.21	250	3/4	30x2.0	50.5	32.5	16.0	36	32	188
ESS-28LR 3.4	708.1623.845.21	250	3/4	36x2.0	54.0	35.0	16.0	41	32	217
ESS-28LR 1.1	708.1623.850.21	250	1	36x2.0	56.0	35.0	18.0	41	41	264
ESS-35LR 5.4	708.1623.944.21	250	1 1/4	45x2.0	63.5	42.5	20.0	50	50	438
ESS-42LR 3.2	708.1623.992.21	250	1 1/2	52x2.0	67.5	46.5	22.0	60	55	630
ESS-06SR 1.8	708.1623.100.31	800	1/8	14x1.5	33.0	24.5	8.0	17	14	33
ESS-06SR 1.4	708.1623.110.31	800	1/4	14x1.5	39.5	27.0	12.0	17	19	42
ESS-08SR 1.4	708.1623.170.31	800	1/4	16x1.5	42.0	29.5	12.0	19	19	58
ESS-10SR 1.4	708.1623.270.31	800	1/4	18x1.5	39.5	27.5	12.0	22	19	66
ESS-10SR 3.8	708.1623.280.31	800	3/8	18x1.5	44.0	32.0	12.0	22	22	81
ESS-10SR 1.2	708.1623.285.31	800	1/2	18x1.5	47.5	34.0	14.0	22	27	112
ESS-12SR 1.4	708.1623.380.31	630	1/4	20x1.5	40.0	28.5	12.0	24	19	72
ESS-12SR 3.8	708.1623.390.31	630	3/8	20x1.5	45.5	34.0	12.0	24	22	110
ESS-12SR 1.2	708.1623.400.31	630	1/2	20x1.5	48.0	34.5	14.0	24	27	127
ESS-14SR 1.2	708.1623.504.31	630	1/2	22x1.5	52.0	37.0	14.0	27	27	142
ESS-16SR 1.2	708.1623.566.31	630	1/2	24x1.5	51.5	37.0	14.0	30	27	160
ESS-16SR 3.4	708.1623.568.31	630	3/4	24x1.5	51.5	35.0	16.0	30	32	211
ESS-20SR 3.4	708.1623.704.31	420	3/4	30x2.0	59.5	43.0	16.0	36	32	261
ESS-25SR 1.1	708.1623.810.31	420	1	36x2.0	66.0	48.0	18.0	46	41	480
ESS-30SR 1.1	708.1623.900.31	420	1	42x2.0	69.0	53.0	18.0	50	41	533
ESS-30SR 5.4	708.1623.902.31	420	1 1/4	42x2.0	69.0	51.0	20.0	50	50	675
ESS-38SR 3.2	708.1623.953.31	420	1 1/2	52x2.0	78.5	60.0	22.0	60	55	1013

Achtung: Für Endmontage des vormontierten Schaftes Überwurfmutter mit 1/4 Umdrehung über den Punkt des deutlich fühlbaren Kraftanstiegs anziehen.

D1=Rohr außen-Ø
M1=metrisches Anschlußgewinde

Attention: For final assembly of the pre-assembled standpipe, tighten the union nut by 1/4 turn beyond the point of the clearly perceptible increase in force.

D1=tube outside diameter
M1=metric connecting thread

Atención: Para el ensamblaje final del vástago premontado, apriete la tuerca de unión 1/4 de vuelta más allá del punto del aumento claramente perceptible de la resistencia.

D1=Ø exterior del tubo
M1=rosca métrica conexión

Einschraubstutzen mit Schaft

Abdichtung durch Profildichtring Form E nach ISO 1179-2

Male adaptor standpipe connectors

profile sealing ring form E acc. ISO 1179-2

Cuerpos para roscar con vástago

cierre hermético mediante junta con perfil forma E según ISO 1179-2

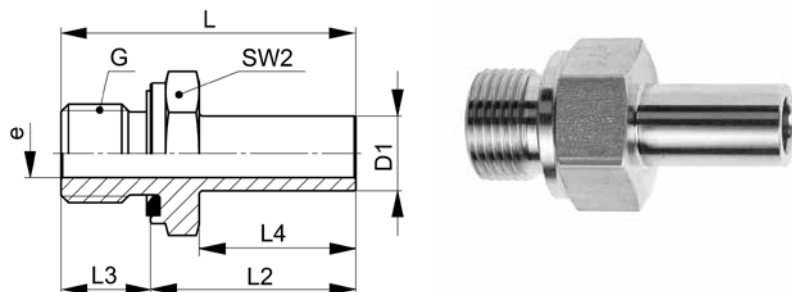

XESS-..LR WD/SR WD

Type-D1 G	Mat.-Nr.	PN	G	L	L2	L3	L4	SW2	e	g/Stk
G=Rohrgewinde (zylindrisch)		G=BSP thread (parallel)			G=rosca de conexión (cilíndrica)					
XESS-08LR/SR 1.4 WD	707.1624.170.13	500	1/4	41.5	29.5	12.0	21.0	19	5.0	33
XESS-10LR/SR 1.4 WD	707.1624.270.13	500	1/4	39.5	27.5	12.0	22.0	19	6.5	26
XESS-10LR/SR 3.8 WD	707.1624.280.13	500	3/8	44.0	32.0	12.0	22.0	22	6.5	51
XESS-12LR/SR 1.4 WD	707.1624.380.13	400	1/4	40.5	28.5	12.0	22.5	19	7.5	30
XESS-12LR/SR 3.8 WD	707.1624.390.13	400	3/8	46.0	34.0	12.0	22.5	22	7.5	58
XESS-12LR/SR 1.2 WD	707.1624.400.13	400	1/2	48.5	34.5	14.0	22.5	27	7.5	93
XESS-06LR 1.8 WD	707.1624.100.20	500	1/8	32.5	24.5	8.0	19.5	14	3.0	13
XESS-15LR 3.8 WD	707.1624.532.20	400	3/8	44.0	32.0	12.0	22.0	22	10.0	54
XESS-15LR 1.2 WD	707.1624.534.20	400	1/2	46.0	32.0	14.0	22.0	27	10.0	84
XESS-18LR 1.2 WD	707.1624.646.20	400	1/2	45.5	31.5	14.0	23.0	27	13.0	73
XESS-22LR 3.4 WD	707.1624.768.20	250	3/4	48.5	32.5	16.0	24.5	32	16.0	113
XESS-22LR 1.1 WD	707.1624.770.20	250	1	55.5	37.5	18.0	24.5	41	16.0	235
XESS-28LR 3.4 WD	707.1624.845.20	250	3/4	51.0	35.0	16.0	25.0	32	19.0	116
XESS-28LR 1.1 WD	707.1624.850.20	250	1	53.0	35.0	18.0	25.0	41	22.0	183
XESS-35LR 5.4 WD	707.1624.944.20	250	1 1/4	62.5	42.5	20.0	30.0	50	28.0	334
XESS-42LR 3.2 WD	707.1624.992.20	250	1 1/2	69.5	46.5	22.0	30.5	55	34.0	462
XESS-06SR 1.4 WD	707.1624.110.30	800	1/4	39.0	27.0	12.0	20.0	19	3.0	29
XESS-14SR 1.2 WD	707.1624.504.30	630	1/2	51.0	37.0	14.0	24.0	27	9.0	100
XESS-16SR 1.2 WD	707.1624.566.30	630	1/2	51.0	37.0	14.0	25.0	27	10.5	96
XESS-16SR 3.4 WD	707.1624.568.30	630	3/4	51.0	35.0	16.0	25.0	32	10.5	136
XESS-20SR 3.4 WD	707.1624.704.30	420	3/4	59.0	43.0	16.0	30.0	32	14.0	155
XESS-25SR 1.1 WD	707.1624.810.30	420	1	66.0	48.0	18.0	33.0	41	17.0	288
XESS-30SR 5.4 WD	707.1624.902.30	420	1 1/4	71.0	51.0	20.0	35.5	50	22.0	447
XESS-38SR 3.2 WD	707.1624.953.30	420	1 1/2	82.0	60.0	22.0	40.0	55	28.0	663

Dichtungsmaterial: FKM (andere Werkstoffe auf Anfrage)

Sealing material: FKM (other materials on request)

Material de junta tórica: FKM (otros materiales bajo demanda)

D1=Rohr außen-Ø
e=kleinster Innen-Ø

D1=tube outside diameter
e=minimum inside diameter

D1=Ø exterior del tubo
e=Ø interior mínimo

Einschraubstutzen mit Schaft

schaftseitig vormontiert, Abdichtung durch Profildichtring Form E nach ISO 1179-2

Male adaptor standpipe unions

pre-assembled on standpipe side, profile sealing ring form E acc. ISO 1179-2

Racores para roscar con vástago

premontado en lado de vástago, junta con anillo perfilado elástico forma E según ISO 1179-2

10

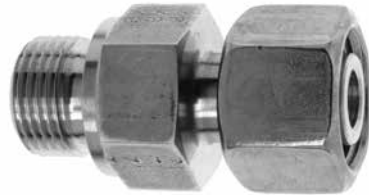
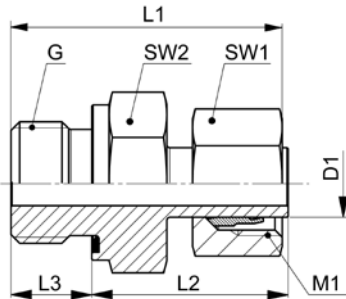

ESS-..LR WD/SR WD

Type-D1 G	Mat.-Nr.	PN	G	M1	L1	L2	L3	SW1	SW2	g/Stk
G=Rohrgewinde (zylindrisch)		G=BSP thread (parallel)			G=rosca de conexión (cilíndrica)					
ESS-06LR 1.8 WD	708.1624.100.21	500	1/8	12x1.5	33.0	24.5	8.0	14	14	25
ESS-08LR 1.4 WD	708.1624.170.21	500	1/4	14x1.5	42.0	29.5	12.0	17	19	47
ESS-10LR 1.4 WD	708.1624.270.21	500	1/4	16x1.5	40.5	27.5	12.0	19	19	49
ESS-10LR 3.8 WD	708.1624.280.21	500	3/8	16x1.5	45.0	32.0	12.0	19	22	62
ESS-12LR 1.4 WD	708.1624.380.21	400	1/4	18x1.5	41.0	28.5	12.0	22	19	58
ESS-12LR 3.8 WD	708.1624.390.21	400	3/8	18x1.5	46.5	34.0	12.0	22	22	74
ESS-12LR 1.2 WD	708.1624.400.21	400	1/2	18x1.5	49.0	34.5	14.0	22	27	108
ESS-15LR 3.8 WD	708.1624.532.21	400	3/8	22x1.5	46.0	32.0	12.0	27	22	90
ESS-15LR 1.2 WD	708.1624.534.21	400	1/2	22x1.5	48.0	32.0	14.0	27	27	107
ESS-18LR 1.2 WD	708.1624.646.21	400	1/2	26x1.5	45.0	31.5	14.0	32	27	140
ESS-22LR 3.4 WD	708.1624.768.21	250	3/4	30x2.0	50.5	32.5	16.0	36	32	188
ESS-22LR 1.1 WD	708.1624.770.21	250	1	30x2.0	57.5	37.5	18.0	36	41	322
ESS-28LR 3.4 WD	708.1624.845.21	250	3/4	36x2.0	54.0	35.0	16.0	41	32	232
ESS-28LR 1.1 WD	708.1624.850.21	250	1	36x2.0	56.0	35.0	18.0	41	41	264
ESS-35LR 5.4 WD	708.1624.944.21	250	1 1/4	45x2.0	63.5	42.5	20.0	50	50	438
ESS-42LR 3.2 WD	708.1624.992.21	250	1 1/2	52x2.0	69.5	46.5	22.0	60	55	630
ESS-06SR 1.4 WD	708.1624.110.31	800	1/4	14x1.5	39.5	27.0	12.0	17	19	42
ESS-08SR 1.4 WD	708.1624.170.31	800	1/4	16x1.5	42.0	29.5	12.0	19	19	58
ESS-10SR 1.4 WD	708.1624.270.31	800	1/4	18x1.5	39.5	27.5	12.0	22	19	50
ESS-10SR 3.8 WD	708.1624.280.31	800	3/8	18x1.5	44.0	32.0	12.0	22	22	81
ESS-12SR 1.4 WD	708.1624.380.31	630	1/4	20x1.5	40.0	28.5	12.0	24	19	78
ESS-12SR 3.8 WD	708.1624.390.31	630	3/8	20x1.5	45.5	34.0	12.0	24	22	110
ESS-12SR 1.2 WD	708.1624.400.31	630	1/2	20x1.5	48.0	34.5	14.0	24	27	127
ESS-14SR 1.2 WD	708.1624.504.31	630	1/2	22x1.5	52.0	37.0	14.0	27	27	142
ESS-16SR 1.2 WD	708.1624.566.31	630	1/2	24x1.5	51.5	37.0	14.0	30	27	160
ESS-16SR 3.4 WD	708.1624.568.31	630	3/4	24x1.5	51.5	35.0	16.0	30	32	211
ESS-20SR 3.4 WD	708.1624.704.31	420	3/4	30x2.0	59.5	43.0	16.0	36	32	261
ESS-25SR 1.1 WD	708.1624.810.31	420	1	36x2.0	66.0	48.0	18.0	46	41	480
ESS-30SR 5.4 WD	708.1624.902.31	420	1 1/4	42x2.0	69.0	51.0	20.0	50	50	675
ESS-38SR 3.2 WD	708.1624.953.31	420	1 1/2	52x2.0	78.5	60.0	22.0	60	55	899

Achtung: Für Endmontage des vormontierten Schaftes Überwurfmutter mit 1/4 Umdrehung über den Punkt des deutlich fühlbaren Kraftanstiegs anziehen.

Attention: For final assembly of the pre-assembled standpipe, tighten the union nut by 1/4 turn beyond the point of the clearly perceptible increase in force.

Atención: Para el ensamblaje final del vástago premontado, apriete la tuerca de unión 1/4 de vuelta más allá del punto del aumento claramente perceptible de la resistencia.

Dichtungsmaterial: FKM (andere Werkstoffe auf Anfrage)

Sealing material: FKM (other materials on request)

Material de junta tórica: FKM (otros materiales bajo demanda)

D1=Rohr außen-Ø
M1=metrisches Anschlußgewinde

D1=tube outside diameter
M1=metric connecting thread

D1=Ø exterior del tubo
M1=rosca métrica conexión

Einschraubstutzen mit Schaft

Abdichtung durch Dichtkante Form B nach DIN 3852-2

Male adaptor standpipe connectors

sealing edge form B acc. DIN 3852-2

Cuerpos para roscar con vástago

cierre hermético con borde de obturación forma B según DIN 3852-2

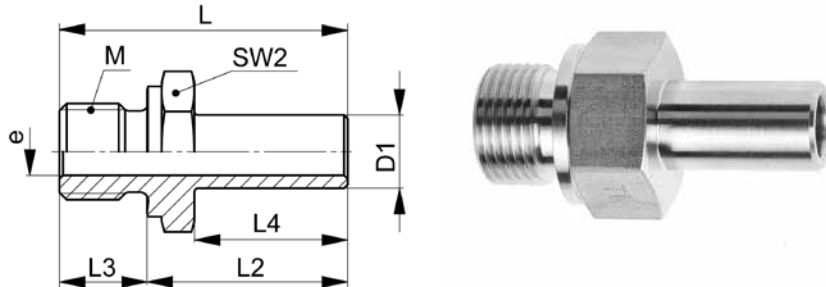

XESS-..LM/SM

Type-D1 M	Mat.-Nr.	PN	M	L	L2	L3	L4	SW2	e	g/Stk
M=metrisches Gewinde (zylindrisch)		M=metric thread (parallel)				M=rosca métrica (cilíndrica)				
XESS-06LM 10x1,0	706.1622.180.20	500	10x1.0	32.5	24.5	8.0	19.5	14	3.2	13
XESS-08LM 12x1,5	706.1622.240.20	500	12x1.5	41.5	29.5	12.0	21.0	17	5.0	28
XESS-10LM 14x1,5	706.1622.278.20	500	14x1.5	39.5	27.5	12.0	21.0	19	6.5	31
XESS-12LM 16x1,5	706.1622.330.20	400	16x1.5	46.0	34.0	12.0	21.0	22	8.0	60
XESS-15LM 18x1,5	706.1622.390.20	400	18x1.5	46.0	34.0	12.0	22.0	24	10.0	70
XESS-18LM 22x1,5	706.1622.460.20	400	22x1.5	45.5	31.5	14.0	23.0	27	13.0	79
XESS-22LM 26x1,5	706.1622.535.20	250	26x1.5	48.5	32.5	16.0	24.5	32	16.0	114
XESS-06SM 12x1,5	706.1622.190.30	800	12x1.5	39.0	27.0	12.0	20.0	17	3.2	25
XESS-12SM 18x1,5	706.1622.333.30	630	18x1.5	46.0	34.0	12.0	22.5	24	7.0	71
XESS-25SM 33x2,0	706.1622.550.30	420	33x2.0	66.0	48.0	18.0	33.0	41	17.0	292

D1=Rohr außen-Ø
e=kleinster Innen-Ø

D1=tube outside diameter
e=minimum inside diameter

D1=Ø exterior del tubo
e=Ø interior mínimo

Einschraubstutzen mit Schaft

schaftseitig vormontiert, Abdichtung durch Dichtkante Form B nach DIN 3852-2

Male adaptor standpipe unions

pre-assembled on standpipe side, sealing edge form B acc. DIN 3852-2

Racores para roscar con vástago

premontado en lado de vástago, cierre hermético mediante borde de obturación forma B según DIN 3852-2

10

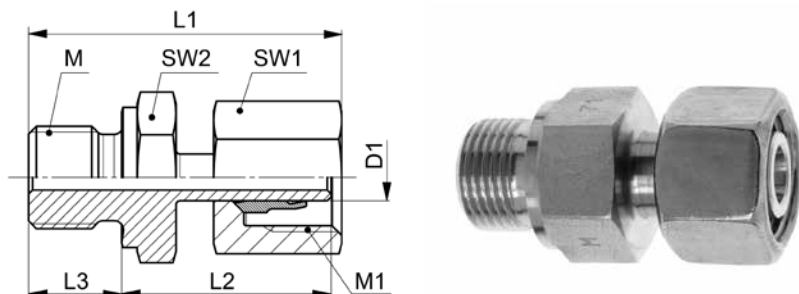

ESS-..LM/SM

Type-D1 M	Mat.-Nr.	PN	M	M1	L1	L2	L3	SW1	SW2	g/Stk
M=metrisches Gewinde (zylindrisch)		M=metric thread (parallel)				M=rosca métrica (cilíndrica)				
ESS-06LM 10x1,0	708.1622.180.21	500	10x1.0	12x1.5	33.0	24.5	8.0	14	14	29
ESS-08LM 12x1,5	708.1622.240.21	500	12x1.5	14x1.5	42.0	29.5	12.0	17	17	38
ESS-10LM 14x1,5	708.1622.278.21	500	14x1.5	16x1.5	40.5	27.5	12.0	19	19	50
ESS-12LM 16x1,5	708.1622.330.21	400	16x1.5	18x1.5	46.5	34.0	12.0	22	22	65
ESS-15LM 18x1,5	708.1622.390.21	400	18x1.5	22x1.5	48.0	34.0	12.0	27	24	100
ESS-18LM 22x1,5	708.1622.460.21	400	22x1.5	26x1.5	45.0	31.5	14.0	32	27	140
ESS-22LM 26x1,5	708.1622.535.21	250	26x1.5	30x2.0	50.5	32.5	16.0	36	32	188
ESS-06SM 12x1,5	708.1622.190.31	800	12x1.5	14x1.5	39.5	27.0	12.0	17	17	40
ESS-12SM 18x1,5	708.1622.333.31	630	18x1.5	20x1.5	45.5	34.0	12.0	24	24	111
ESS-25SM 33x2,0	708.1622.550.31	420	33x2.0	36x2.0	66.0	48.0	18.0	46	41	480

Achtung: Für Endmontage des vormontierten Schaftes Überwurfmutter mit 1/4 Umdrehung über den Punkt des deutlich fühlbaren Kraftanstiegs anziehen.

Attention: For final assembly of the pre-assembled standpipe, tighten the union nut by 1/4 turn beyond the point of the clearly perceptible increase in force.

Atención: Para el ensamblaje final del vástago premontado, apriete la tuerca de unión 1/4 de vuelta más allá del punto del aumento claramente perceptible de la resistencia.

D1=Rohr außen-Ø
M1=metrisches Anschlußgewinde

D1=tube outside diameter
M1=metric connecting thread

D1=Ø exterior del tubo
M1=rosca métrica conexión

Einschraubstutzen mit Schaft

Abdichtung durch Profildichtring Form E nach ISO 1179-2

Male adaptor standpipe connectors

profile sealing ring form E acc. ISO 1179-2

Cuerpos para roscar con vástago

cierre hermético mediante junta con perfil forma E según ISO 1179-2

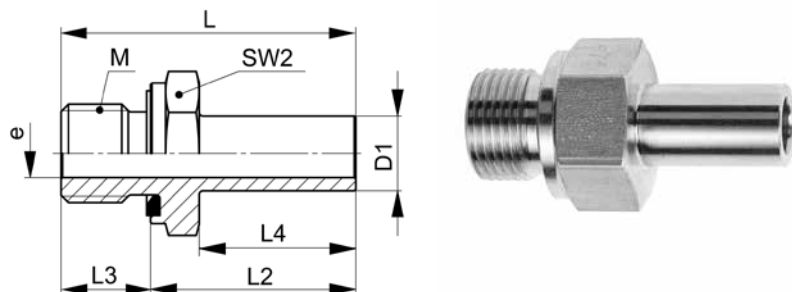

XESS-..LM WD/SM WD

Type-D1 M	Mat.-Nr.	PN	M	L	L2	L3	L4	SW2	e	g/Stk
M=metrisches Gewinde (zylindrisch)		M=metric thread (parallel)				M=rosca métrica (cilíndrica)				
XESS-06LM 10x1,0 WD	707.1625.180.20	500	10x1.0	32.5	24.5	8.0	19.5	14	3.2	13
XESS-10LM 14x1,5 WD	707.1625.278.20	500	14x1.5	39.5	27.5	12.0	21.0	19	6.5	30
XESS-12LM 16x1,5 WD	707.1625.330.20	400	16x1.5	46.0	34.0	12.0	21.0	22	8.0	59
XESS-15LM 18x1,5 WD	707.1625.390.20	400	18x1.5	46.0	34.0	12.0	22.0	24	10.0	69
XESS-18LM 22x1,5 WD	707.1625.460.20	400	22x1.5	45.5	31.5	14.0	23.0	27	13.0	78
XESS-22LM 26x1,5 WD	707.1625.535.20	250	26x1.5	48.5	32.5	16.0	24.5	32	16.0	113
XESS-35LM 42x2,0 WD	707.1625.600.20	250	42x2.0	62.5	42.5	20.0	30.0	50	28.0	338
XESS-06SM 12x1,5 WD	707.1625.190.30	800	12x1.5	39.0	27.0	12.0	20.0	17	3.2	24
XESS-10SM 16x1,5 WD	707.1625.285.30	800	16x1.5	44.0	32.0	12.0	22.0	22	6.0	52
XESS-12SM 18x1,5 WD	707.1625.333.30	630	18x1.5	46.0	34.0	12.0	22.5	24	7.0	71
XESS-14SM 20x1,5 WD	707.1625.382.30	630	20x1.5	51.0	37.0	14.0	24.0	27	9.0	98
XESS-16SM 22x1,5 WD	707.1625.410.30	630	22x1.5	51.0	37.0	14.0	25.0	27	10.5	102
XESS-25SM 33x2,0 WD	707.1625.550.30	420	33x2.0	66.0	48.0	18.0	33.0	41	17.0	289

Dichtungsmaterial: FKM (andere Werkstoffe auf Anfrage)

Sealing material: FKM (other materials on request)

Material de junta tórica: FKM (otros materiales bajo demanda)

D1=Rohr außen-Ø
e=kleinster Innen-Ø

D1=tube outside diameter
e=minimum inside diameter

D1=Ø exterior del tubo
e=Ø interior mínimo

Einschraubstutzen mit Schaft

schaftseitig vormontiert, Abdichtung durch Profildichtring Form E nach ISO 1179-2

Male adaptor standpipe unions

pre-assembled on standpipe side, profile sealing ring form E acc. ISO 1179-2

Racores para roscar con vástago

premontado en lado de vástago, cierre hermético mediante junta con perfil forma E según ISO 1179-2

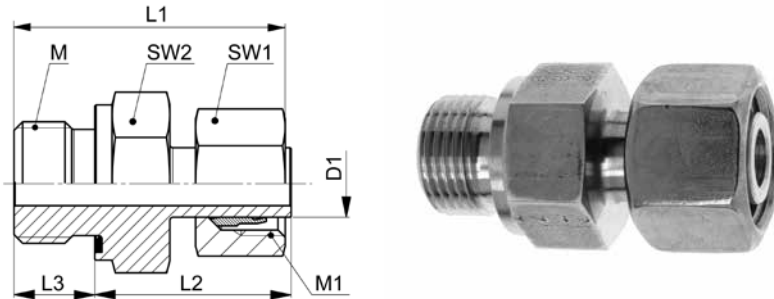

ESS-..LM WD/SM WD

Type-D1 M	Mat.-Nr.	PN	M	M1	L1	L2	L3	SW1	SW2	g/Stk
M=metrisches Gewinde (zylindrisch)		M=metric thread (parallel)				M=rosca métrica (cilíndrica)				
ESS-06LM 10x1,0 WD	708.1625.180.21	500	10x1.0	12x1.5	33.0	24.5	8.0	14	14	29
ESS-10LM 14x1,5 WD	708.1625.278.21	500	14x1.5	16x1.5	40.5	27.5	12.0	19	19	50
ESS-12LM 16x1,5 WD	708.1625.330.21	400	16x1.5	18x1.5	46.5	34.0	12.0	22	22	65
ESS-15LM 18x1,5 WD	708.1625.390.21	400	18x1.5	22x1.5	48.0	34.0	12.0	27	24	100
ESS-18LM 22x1,5 WD	708.1625.460.21	400	22x1.5	26x1.5	45.0	31.5	14.0	32	27	140
ESS-22LM 26x1,5 WD	708.1625.535.21	250	26x1.5	30x2.0	50.5	32.5	16.0	36	32	188
ESS-35LM 42x2,0 WD	708.1625.600.21	250	42x2.0	45x2.0	63.5	42.5	20.0	50	50	466
ESS-06SM 12x1,5 WD	708.1625.190.31	800	12x1.5	14x1.5	39.5	27.0	12.0	17	17	40
ESS-10SM 16x1,5 WD	708.1625.285.31	800	16x1.5	18x1.5	44.0	32.0	12.0	22	22	80
ESS-12SM 18x1,5 WD	708.1625.333.31	630	18x1.5	20x1.5	45.5	34.0	12.0	24	24	111
ESS-14SM 20x1,5 WD	708.1625.382.31	630	20x1.5	22x1.5	52.0	37.0	14.0	27	27	140
ESS-16SM 22x1,5 WD	708.1625.410.31	630	22x1.5	24x1.5	51.5	37.0	14.0	30	27	168
ESS-25SM 33x2,0 WD	708.1625.550.31	420	33x2.0	36x2.0	66.0	48.0	18.0	46	41	480

Achtung: Für Endmontage des vormontierten Schaftes Überwurfmutter mit 1/4 Umdrehung über den Punkt des deutlich fühlbaren Kraftanstiegs anziehen.

Attention: For final assembly of the pre-assembled standpipe, tighten the union nut by 1/4 turn beyond the point of the clearly perceptible increase in force.

Atención: Para el ensamblaje final del vástago premontado, apriete la tuerca de unión 1/4 de vuelta más allá del punto del aumento claramente perceptible de la resistencia.

Dichtungsmaterial: FKM (andere Werkstoffe auf Anfrage)

Sealing material: FKM (other materials on request)

Material de junta tórica: FKM (otros materiales bajo demanda)

D1=Rohr außen-Ø
M1=metrisches Anschlußgewinde

D1=tube outside diameter
M1=metric connecting thread

D1=Ø exterior del tubo
M1=rosca métrica conexión

Einschraubstutzen NPT mit Schaft
Male adaptor NPT standpipe connectors
Cuerpos para roscar con vástago NPT

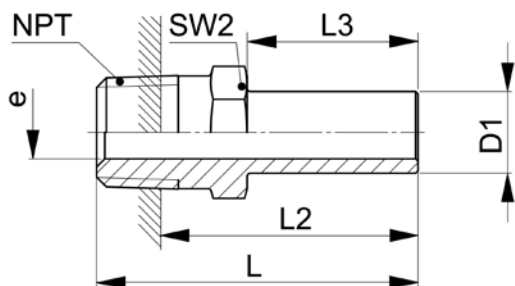

XESS-..LNPT/SNPT

Type-D1 NPT	Mat.-Nr.	PN	L	L2	L3	SW2	e	g/Stk
NPT=Einschraubgewinde NPT		NPT=tapered male adaptor thread NPT				NPT=rosca de conexión cónica NPT		
XESS-08LNPT/SNPT 1.4	706.1602.170.13	500	40.5	30.5	21.0	14	5.0	26
XESS-10LNPT/SNPT 1.4	706.1602.270.13	500	40.5	30.5	22.0	14	6.5	25
XESS-12LNPT/SNPT 1.4	706.1602.380.13	400	45.0	35.0	22.5	14	7.5	30
XESS-12LNPT/SNPT 3.8	706.1602.390.13	400	45.0	35.0	22.5	19	7.5	44
XESS-12LNPT/SNPT 1.2	706.1602.400.13	400	48.0	34.0	22.5	22	7.5	73
XESS-06LNPT 1.8	706.1602.100.20	500	33.0	26.0	20.0	11	3.5	11
XESS-15LNPT 3.8	706.1602.532.20	400	45.0	35.0	22.0	19	10.0	51
XESS-15LNPT 1.2	706.1602.534.20	400	47.0	33.0	22.0	22	10.0	76
XESS-18LNPT 1.2	706.1602.646.20	400	49.0	35.0	23.0	22	13.0	72
XESS-22LNPT 3.4	706.1602.768.20	250	50.0	36.0	24.5	27	16.0	105
XESS-28LNPT 1.1	706.1602.850.20	250	60.0	42.0	25.0	36	22.0	200
XESS-35LNPT 5.4	706.1602.944.20	250	68.0	50.0	30.0	46	28.0	357
XESS-42LNPT 3.2	706.1602.992.20	250	68.5	50.5	30.5	50	34.0	420
XESS-10SNPT 3.8	706.1602.280.30	800	43.0	33.0	22.0	19	6.0	47
XESS-14SNPT 1.2	706.1602.504.30	630	50.0	36.0	24.0	22	9.0	80
XESS-16SNPT 1.2	706.1602.566.30	630	50.0	36.0	25.0	22	10.5	78
XESS-20SNPT 3.4	706.1602.704.30	420	59.0	45.0	30.0	27	14.0	132
XESS-25SNPT 1.1	706.1602.810.30	420	66.0	48.0	33.0	36	17.0	250
XESS-30SNPT 5.4	706.1602.902.30	420	71.0	53.0	35.5	46	22.0	408
XESS-38SNPT 3.2	706.1602.953.30	420	82.0	64.0	40.0	50	28.0	607

D1=Rohr außen-Ø
 e=kleinster Innen-Ø

D1=tube outside diameter
 e=minimum inside diameter

D1=Ø exterior del tubo
 e=Ø interior mínimo

Einschraubstutzen NPT mit Schaft

schaftseitig vormontiert

Male adaptor NPT standpipe unions

pre-assembled on standpipe side

Racores para roscar NPT con vástago

premontado en lado de vástago

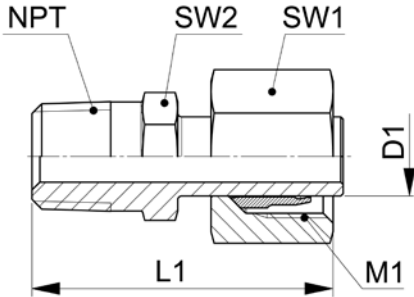

10

ESS..LNPT/SNPT

Type-D1 NPT	Mat.-Nr.	PN	NPT	M1	L1	SW1	SW2	g/Stk
NPT=Einschraubgewinde NPT		NPT=tapered male adaptor thread NPT			NPT=rosca de conexión cónica NPT			
ESS-06LNPT 1.8	708.1602.100.21	500	1/8	12x1.5	33.5	14	11	26
ESS-08LNPT 1.4	708.1602.170.21	500	1/4	14x1.5	41.0	17	14	54
ESS-10LNPT 1.4	708.1602.270.21	500	1/4	16x1.5	41.5	19	14	47
ESS-12LNPT 1.4	708.1602.380.21	400	1/4	18x1.5	44.5	22	14	52
ESS-12LNPT 3.8	708.1602.390.21	400	3/8	18x1.5	44.5	22	19	70
ESS-12LNPT 1.2	708.1602.400.21	400	1/2	18x1.5	47.5	22	22	114
ESS-15LNPT 3.8	708.1602.532.21	400	3/8	22x1.5	47.0	27	19	95
ESS-15LNPT 1.2	708.1602.534.21	400	1/2	22x1.5	49.0	27	22	109
ESS-18LNPT 1.2	708.1602.646.21	400	1/2	26x1.5	48.5	32	22	130
ESS-22LNPT 3.4	708.1602.768.21	250	3/4	30x2.0	52.0	36	27	185
ESS-28LNPT 1.1	708.1602.850.21	250	1	36x2.0	63.0	41	36	299
ESS-35LNPT 5.4	708.1602.944.21	250	1 1/4	45x2.0	69.0	50	46	405
ESS-42LNPT 3.2	708.1602.992.21	250	1 1/2	52x2.0	69.5	60	50	570
ESS-08SNPT 1.4	708.1602.170.31	800	1/4	16x1.5	41.0	19	14	56
ESS-10SNPT 1.4	708.1602.270.31	800	1/4	18x1.5	40.5	22	14	58
ESS-10SNPT 3.8	708.1602.280.31	800	3/8	18x1.5	43.0	22	19	80
ESS-12SNPT 1.4	708.1602.380.31	630	1/4	20x1.5	44.5	24	14	64
ESS-12SNPT 3.8	708.1602.390.31	630	3/8	20x1.5	44.5	24	19	80
ESS-12SNPT 1.2	708.1602.400.31	630	1/2	20x1.5	47.5	24	22	116
ESS-14SNPT 1.2	708.1602.504.31	630	1/2	22x1.5	51.0	27	22	145
ESS-16SNPT 1.2	708.1602.566.31	630	1/2	24x1.5	50.5	30	22	150
ESS-20SNPT 3.4	708.1602.704.31	420	3/4	30x2.0	59.5	36	27	255
ESS-25SNPT 1.1	708.1602.810.31	420	1	36x2.0	66.0	46	36	500
ESS-30SNPT 5.4	708.1602.902.31	420	1 1/4	42x2.0	69.0	50	46	620
ESS-38SNPT 3.2	708.1602.953.31	420	1 1/2	52x2.0	78.5	60	50	890

Achtung: Für Endmontage des vormontierten Schaftes Überwurfmutter mit 1/4 Umdrehung über den Punkt des deutlich fühlbaren Kraftanstiegs anziehen.

Attention: For final assembly of the pre-assembled standpipe, tighten the union nut by 1/4 turn beyond the point of the clearly perceptible increase in force.

Atención: Para el ensamblaje final del vástago premontado, apriete la tuerca de unión 1/4 de vuelta más allá del punto del aumento claramente perceptible de la resistencia.

D1=Rohraußen-Ø
M1=metrisches Anschlußgewinde

D1=tube outside diameter
M1=metric connecting thread

D1=Ø exterior del tubo
M1=rosca métrica conexión

Einstellbare Winkelstutzen 45° mit Dichtkegel und O-Ring

dichtkegelseitig vormontiert

Adjustable elbow connectors 45° with taper and O-ring

pre-assembled on tapered nipple side

Cuerpos angulares ajustables 45° con junta cónica y junta tórica

premontado en lado de junta cónica

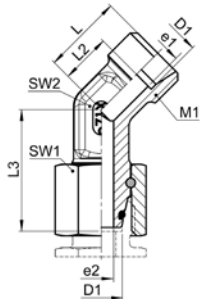

XEWKO-..L M 45°

Type-D1	Mat.-Nr.	PN	M1	L	L2	L3	SW1	SW2	e1	e2	g/Stk
XEWKO-06L 45° M	707.2660.060.20	315	12x1.5	16.0	9.0	26.0	14	12	4.0	3.0	33
XEWKO-08L 45° M	707.2660.080.20	315	14x1.5	19.0	12.0	27.5	17	12	6.0	4.0	45
XEWKO-10L 45° M	707.2660.100.20	315	16x1.5	19.0	12.0	29.0	19	14	8.0	6.0	60
XEWKO-12L 45° M	707.2660.120.20	315	18x1.5	21.0	14.0	29.5	22	17	10.0	8.0	80
XEWKO-15L 45° M	707.2660.150.20	315	22x1.5	24.0	17.0	32.5	27	19	12.0	10.0	131
XEWKO-18L 45° M	707.2660.180.20	315	26x1.5	24.0	16.5	35.5	32	24	15.0	13.0	180
XEWKO-22L 45° M	707.2660.220.20	160	30x2.0	26.0	18.5	38.5	36	27	24.0	22.0	243
XEWKO-28L 45° M	707.2660.280.20	160	36x2.0	30.5	23.0	41.5	41	36	19.0	17.0	378
XEWKO-35L 45° M	707.2660.350.20	160	45x2.0	37.0	26.5	51.0	50	41	30.0	28.0	565
XEWKO-42L 45° M	707.2660.420.20	160	52x2.0	37.0	26.0	56.0	60	50	36.0	34.0	848

Dichtungsmaterial: FKM (andere Werkstoffe auf Anfrage)

Sealing material: FKM (other materials on request)

Material de junta tórica: FKM (otros materiales bajo demanda)

D1=Rohr außen-Ø
M1=metrisches Anschlußgewinde
e1/e2=kleinste Innen-Ø

D1=tube outside diameter
M1=metric connecting thread
e1/e2=minimum inside diameters

D1=Ø exterior del tubo
M1=rosca métrica conexión
e1/e2=Ø interiores mínimo

Einstellbare Winkelverschraubungen 45° mit Dichtkegel und O-Ring
Adjustable elbow fittings 45° with taper and O-ring
Racores angulares ajustables 45° con junta cónica y junta tórica

10

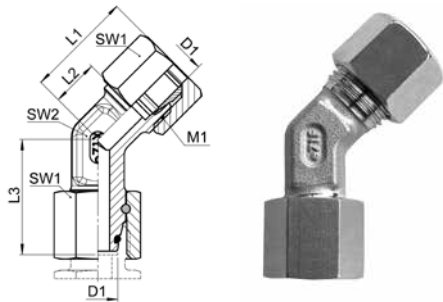

EWKO-..L 45°

Type -D1	Mat.-Nr.	PN	M1	L1	L2	L3	SW1	SW2	g/Stk
EWKO-06L 45°	708.2660.060.20	315	12x1.5	24.0	9.0	26.0	14	12	45
EWKO-08L 45°	708.2660.080.20	315	14x1.5	27.0	12.0	27.5	17	12	63
EWKO-10L 45°	708.2660.100.20	315	16x1.5	27.5	12.0	29.0	19	14	82
EWKO-12L 45°	708.2660.120.20	315	18x1.5	29.5	14.0	29.5	22	17	112
EWKO-15L 45°	708.2660.150.20	315	22x1.5	33.5	17.0	32.5	27	19	181
EWKO-18L 45°	708.2660.180.20	315	26x1.5	33.5	16.5	35.5	32	24	253
EWKO-22L 45°	708.2660.220.20	160	30x2.0	36.5	18.5	38.5	36	27	340
EWKO-28L 45°	708.2660.280.20	160	36x2.0	40.5	23.0	41.5	41	36	490
EWKO-35L 45°	708.2660.350.20	160	45x2.0	49.5	26.5	51.0	50	41	741
EWKO-42L 45°	708.2660.420.20	160	52x2.0	50.0	26.0	56.0	60	50	1117

Baumaße sind Ungefährmaße bei angezogener Überwurfmutter.

Sizes are approximate dimensions at tightened nut.

Las medidas son aproximadas con la tuerca de unión apretada.

Dichtungsmaterial: FKM (andere Werkstoffe auf Anfrage)

Sealing material: FKM (other materials on request)

Material de junta tórica: FKM (otros materiales bajo demanda)

D1=Rohr außen-Ø
M1=metrisches Anschlußgewinde

D1=tube outside diameter
M1=metric connecting thread

D1=Ø exterior del tubo
M1=rosca métrica conexión

Einstellbare Winkelstutzen mit Dichtkegel und O-Ring

dichtkegelseitig vormontiert

Adjustable elbow connectors with taper and O-ring

pre-assembled on tapered nipple side

Cuerpos angulares ajustables con junta cónica y junta tórica

premontado en lado de junta cónica

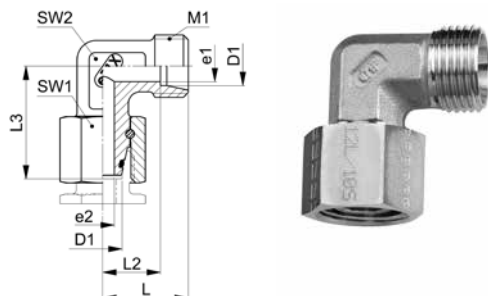

XEWKO-..L/S M

Type-D1	Mat.-Nr.	PN	M1	L	L2	L3	SW1	SW2	e1	e2	g/Stk
XEWKO-06L M	707.2670.060.20	315	12x1.5	19.0	12.0	26.0	14	12	4.0	3.0	31
XEWKO-08L M	707.2670.080.20	315	14x1.5	21.0	14.0	27.5	17	12	6.0	4.0	42
XEWKO-10L M	707.2670.100.20	315	16x1.5	22.0	15.0	29.0	19	14	8.0	6.0	58
XEWKO-12L M	707.2670.120.20	315	18x1.5	24.0	17.0	29.5	22	17	10.0	8.0	77
XEWKO-15L M	707.2670.150.20	315	22x1.5	28.0	21.0	32.5	27	19	12.0	10.0	130
XEWKO-18L M	707.2670.180.20	315	26x1.5	31.0	23.5	35.5	32	24	15.0	13.0	180
XEWKO-22L M	707.2670.220.20	160	30x2.0	35.0	27.5	38.5	36	27	19.0	17.0	254
XEWKO-28L M	707.2670.280.20	160	36x2.0	38.0	30.5	41.5	41	36	24.0	22.0	371
XEWKO-35L M	707.2670.350.20	160	45x2.0	45.0	34.5	51.0	50	41	30.0	28.0	551
XEWKO-42L M	707.2670.420.20	160	52x2.0	51.0	40.0	56.0	60	50	36.0	34.0	868
XEWKO-06S M	707.2670.060.30	630	14x1.5	23.0	16.0	27.0	17	12	4.0	3.0	46
XEWKO-08S M	707.2670.080.30	630	16x1.5	24.0	17.0	27.5	19	14	5.0	4.0	65
XEWKO-10S M	707.2670.100.30	630	18x1.5	25.0	17.5	30.0	22	17	7.0	6.0	88
XEWKO-12S M	707.2670.120.30	630	20x1.5	29.0	21.5	31.0	24	17	8.0	8.0	106
XEWKO-14S M	707.2670.140.30	630	22x1.5	30.0	22.0	35.0	27	19	10.0	9.0	144
XEWKO-16S M	707.2670.160.30	400	24x1.5	33.0	24.5	36.5	30	24	12.0	11.0	196
XEWKO-20S M	707.2670.200.30	400	30x2.0	37.0	26.5	44.5	36	27	16.0	14.0	300
XEWKO-25S M	707.2670.250.30	400	36x2.0	42.0	30.0	50.0	46	36	20.0	18.0	539
XEWKO-30S M	707.2670.300.30	400	42x2.0	49.0	35.5	55.0	50	41	25.0	23.0	719
XEWKO-38S M	707.2670.380.30	315	52x2.0	57.0	41.0	63.0	60	50	32.0	30.0	1094

Dichtungsmaterial: FKM (andere Werkstoffe auf Anfrage)

Sealing material: FKM (other materials on request)

Material de junta tórica: FKM (otros materiales bajo demanda)

ISO 8434-1-SWOE

D1=Rohr außen-Ø
M1=metrisches Anschlußgewinde
e1/e2=kleinste Innen-Ø

D1=tube outside diameter
M1=metric connecting thread
e1/e2=minimum inside diameters

D1=Ø exterior del tubo
M1=rosca métrica conexión
e1/e2=Ø interiores mínimo

Einstellbare Winkelverschraubungen mit Dichtkegel und O-Ring
Adjustable elbow fittings with taper and O-ring
Racores angulares ajustables con junta cónica y junta tórica

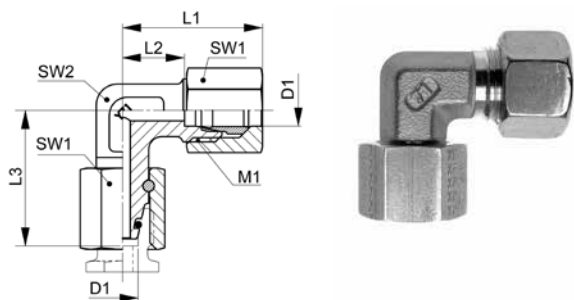

10

EWKO-..L/S

Type -D1	Mat.-Nr.	PN	M1	L1	L2	L3	SW1	SW2	g/Stk
EWKO-06L	708.2670.060.20	315	12x1.5	27.0	12.0	26.0	14	12	43
EWKO-08L	708.2670.080.20	315	14x1.5	29.0	14.0	27.5	17	12	59
EWKO-10L	708.2670.100.20	315	16x1.5	30.5	15.0	29.0	19	14	80
EWKO-12L	708.2670.120.20	315	18x1.5	32.0	17.0	29.5	22	17	105
EWKO-15L	708.2670.150.20	315	22x1.5	36.0	21.0	32.5	27	19	175
EWKO-18L	708.2670.180.20	315	26x1.5	40.0	23.5	35.5	32	24	248
EWKO-22L	708.2670.220.20	160	30x2.0	44.0	27.5	38.5	36	27	344
EWKO-28L	708.2670.280.20	160	36x2.0	47.0	30.5	41.5	41	36	476
EWKO-35L	708.2670.350.20	160	45x2.0	56.0	34.5	51.0	50	41	715
EWKO-42L	708.2670.420.20	160	52x2.0	63.0	40.0	56.0	60	50	1121
EWKO-06S	708.2670.060.30	630	14x1.5	31.0	16.0	27.0	17	12	64
EWKO-08S	708.2670.080.30	630	16x1.5	32.0	17.0	27.5	19	14	86
EWKO-10S	708.2670.100.30	630	18x1.5	34.0	17.5	30.0	22	17	120
EWKO-12S	708.2670.120.30	630	20x1.5	38.0	21.5	31.0	24	17	143
EWKO-14S	708.2670.140.30	630	22x1.5	40.0	22.0	35.0	27	19	188
EWKO-16S	708.2670.160.30	400	24x1.5	43.0	24.5	36.5	30	24	265
EWKO-20S	708.2670.200.30	400	30x2.0	48.0	26.5	44.5	36	27	412
EWKO-25S	708.2670.250.30	400	36x2.0	54.0	30.0	50.0	46	36	763
EWKO-30S	708.2670.300.30	400	42x2.0	62.0	35.5	55.0	50	41	968
EWKO-38S	708.2670.380.30	315	52x2.0	72.0	41.0	63.0	60	50	1458

Baumaße sind Ungefährmaße bei angezogener Überwurfmutter.

Sizes are approximate dimensions at tightened nut.

Las medidas son aproximadas con la tuerca de unión apretada.

Dichtungsmaterial: FKM (andere Werkstoffe auf Anfrage)

Sealing material: FKM (other materials on request)

Material de junta tórica: FKM (otros materiales bajo demanda)

ISO 8434-1-SWOEC

D1=Rohraußen-Ø
M1=metrisches Anschlußgewinde

D1=tube outside diameter
M1=metric connecting thread

D1=Ø exterior del tubo
M1=rosca métrica conexión

Einstellbare Winkel-Einschraubverschraubungen mit Dichtkegel und O-Ring

mit Einschraubstutzen, Abdichtung durch Dichtkante Form B nach DIN 3852-2

Adjustable male adaptor elbow fittings with taper and O-ring

with male adaptor connector, sealing edge form B acc. DIN 3852-2

Racores para roscar en codo ajustables con junta cónica y junta tórica

con racor para roscar, cierre hermético mediante borde de obturación forma B según DIN 3852-2

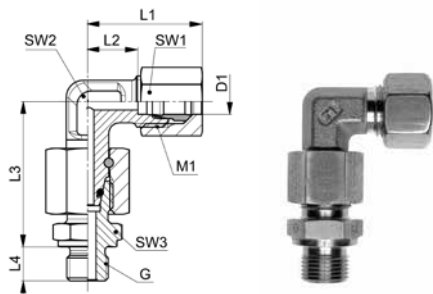

EWKO-..LR/SR

Type-D1 G	Mat.-Nr.	PN	G	M1	L1	L2	L3	L4	SW1	SW2	SW3	g/Stk
G=Rohrgewinde (zylindrisch)		G=BSP thread (parallel)					G=rosca de conexión (cilíndrica)					
EWKO-06LR 1.8	708.2671.100.20	315	1/8	12x1.5	27.0	12.0	34.5	8.0	14	12	14	57
EWKO-08LR 1.4	708.2671.170.20	315	1/4	14x1.5	29.0	14.0	37.0	12.0	17	12	19	87
EWKO-10LR 1.4	708.2671.270.20	315	1/4	16x1.5	30.5	15.0	39.5	12.0	19	14	19	109
EWKO-12LR 1.4	708.2671.380.20	315	1/4	18x1.5	32.0	17.0	41.5	12.0	22	17	19	137
EWKO-12LR 3.8	708.2671.390.20	315	3/8	18x1.5	32.0	17.0	42.0	12.0	22	17	22	147
EWKO-12LR 1.2	708.2671.400.20	315	1/2	18x1.5	32.0	17.0	42.5	14.0	22	17	27	175
EWKO-15LR 1.2	708.2671.534.20	315	1/2	22x1.5	36.0	21.0	46.5	14.0	27	19	27	248
EWKO-18LR 1.2	708.2671.646.20	315	1/2	26x1.5	40.0	23.5	50.0	14.0	32	24	27	320
EWKO-22LR 3.4	708.2671.768.20	160	3/4	30x2.0	44.0	27.5	55.0	16.0	36	27	32	450
EWKO-28LR 1.1	708.2671.850.20	160	1	36x2.0	47.0	30.5	59.0	18.0	41	36	41	349
EWKO-35LR 5.4	708.2671.944.20	160	1 1/4	45x2.0	56.0	34.5	68.5	20.0	50	41	50	996
EWKO-42LR 3.2	708.2671.992.20	160	1 1/2	52x2.0	63.0	40.0	75.0	22.0	60	50	60	1482
EWKO-06SR 1.4	708.2671.110.30	630	1/4	14x1.5	31.0	16.0	40.0	12.0	17	12	19	98
EWKO-08SR 1.4	708.2671.170.30	630	1/4	16x1.5	32.0	17.0	42.0	12.0	19	14	19	128
EWKO-10SR 3.8	708.2671.280.30	630	3/8	18x1.5	34.0	17.5	45.0	12.0	22	17	22	178
EWKO-12SR 3.8	708.2671.390.30	630	3/8	20x1.5	38.0	21.5	48.0	12.0	24	17	22	207
EWKO-12SR 1.2	708.2671.400.30	630	1/2	20x1.5	38.0	21.5	48.5	14.0	24	17	27	242
EWKO-14SR 1.2	708.2671.504.30	630	1/2	22x1.5	40.0	22.0	54.0	14.0	27	19	27	287
EWKO-16SR 1.2	708.2671.566.30	400	1/2	24x1.5	43.0	24.5	55.0	14.0	30	24	27	359
EWKO-20SR 3.4	708.2671.704.30	400	3/4	30x2.0	48.0	26.5	65.0	14.0	36	27	32	567
EWKO-25SR 1.1	708.2671.810.30	400	1	36x2.0	54.0	30.0	73.0	18.0	46	36	41	1036
EWKO-30SR 5.4	708.2671.902.30	400	1 1/4	42x2.0	62.0	35.5	78.5	20.0	50	41	50	1398
EWKO-38SR 3.2	708.2671.953.30	315	1 1/2	52x2.0	72.0	41.0	89.0	22.0	60	50	55	2037

Baumäße sind Ungefährmaße bei angezogener Überwurfmutter.

Sizes are approximate dimensions at tightened nut.

Las medidas son aproximadas con la tuerca de unión apretada.

Dichtungsmaterial: FKM (andere Werkstoffe auf Anfrage)

Sealing material: FKM (other materials on request)

Material de junta tórica: FKM (otros materiales bajo demanda)

D1=Rohr außen-Ø
M1=metrisches Anschlußgewinde

D1=tube outside diameter
M1=metric connecting thread

D1=Ø exterior del tubo
M1=rosca métrica conexión

Einstellbare Winkel-Einschraubverschraubungen mit Dichtkegel und O-Ring

mit Einschraubstutzen, Abdichtung durch Profildichtring Form E nach ISO 1179-2

Adjustable male adaptor elbow fittings with taper and O-ring

with male adaptor connector, profile sealing ring form E acc. ISO 1179-2

Racores para roscar en codo ajustables con junta cónica y junta tórica

con racor para roscar, cierre hermético mediante junta con perfil forma E según ISO 1179-2

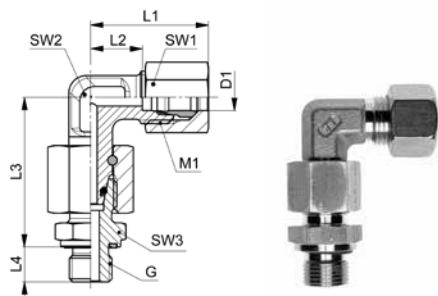

EWKO-..LR WD/SR WD

Type-D1 G	Mat.-Nr.	PN	G	M1	L1	L2	L3	L4	SW1	SW2	SW3	g/Stk
G=Rohrgewinde (zylindrisch)		G=BSP thread (parallel)					G=rosca de conexión (cilíndrica)					
EWKO-06LR 1.8 WD	708.2672.100.20	315	1/8	12x1.5	27.0	12.0	34.0	8.0	14	12	14	57
EWKO-08LR 1.4 WD	708.2672.170.20	315	1/4	14x1.5	29.0	14.0	37.0	12.0	17	12	19	86
EWKO-10LR 1.4 WD	708.2672.270.20	315	1/4	16x1.5	30.5	15.0	40.0	12.0	19	14	19	108
EWKO-12LR 1.4 WD	708.2672.380.20	315	1/4	18x1.5	32.0	17.0	41.5	12.0	22	17	19	134
EWKO-12LR 3.8 WD	708.2672.390.20	315	3/8	18x1.5	32.0	17.0	42.0	12.0	22	17	22	147
EWKO-12LR 1.2 WD	708.2672.400.20	315	1/2	18x1.5	32.0	17.0	42.5	14.0	22	17	27	175
EWKO-15LR 1.2 WD	708.2672.534.20	315	1/2	22x1.5	36.0	21.0	43.5	14.0	27	19	27	248
EWKO-18LR 1.2 WD	708.2672.646.20	315	1/2	26x1.5	40.0	23.5	50.0	14.0	32	24	27	320
EWKO-22LR 3.4 WD	708.2672.768.20	160	3/4	30x2.0	44.0	27.5	55.0	16.0	36	27	32	448
EWKO-28LR 1.1 WD	708.2672.850.20	160	1	36x2.0	47.0	30.5	59.0	18.0	41	36	41	645
EWKO-35LR 5.4 WD	708.2672.944.20	160	1 1/4	45x2.0	56.0	34.5	68.0	20.0	50	41	50	995
EWKO-42LR 3.2 WD	708.2672.992.20	160	1 1/2	52x2.0	63.0	40.0	75.5	22.0	60	50	55	1477
EWKO-06SR 1.4 WD	708.2672.110.30	630	1/4	14x1.5	31.0	16.0	39.0	12.0	17	12	19	100
EWKO-08SR 1.4 WD	708.2672.170.30	630	1/4	16x1.5	32.0	17.0	41.5	12.0	19	14	19	127
EWKO-10SR 3.8 WD	708.2672.280.30	630	3/8	18x1.5	34.0	17.5	45.0	12.0	22	17	22	176
EWKO-12SR 3.8 WD	708.2672.390.30	630	3/8	20x1.5	38.0	21.5	48.0	12.0	24	17	22	207
EWKO-12SR 1.2 WD	708.2672.400.30	630	1/2	20x1.5	38.0	21.5	48.5	14.0	24	17	27	241
EWKO-14SR 1.2 WD	708.2672.504.30	630	1/2	22x1.5	40.0	22.0	54.0	14.0	27	19	27	287
EWKO-16SR 1.2 WD	708.2672.566.30	400	1/2	24x1.5	43.0	24.5	55.0	14.0	30	24	27	359
EWKO-20SR 3.4 WD	708.2672.704.30	400	3/4	30x2.0	48.0	26.5	65.0	18.0	36	27	32	564
EWKO-25SR 1.1 WD	708.2672.810.30	400	1	36x2.0	54.0	30.0	72.5	18.0	46	36	41	1033
EWKO-30SR 5.4 WD	708.2672.944.30	400	1 1/4	42x2.0	62.0	35.5	78.5	18.0	50	41	50	1394
EWKO-38SR 3.2 WD	708.2672.953.30	315	1 1/2	52x2.0	72.0	41.0	89.0	22.0	60	50	55	2033

Baumäße sind Ungefährmaße bei angezogener Überwurfmutter.

Sizes are approximate dimensions at tightened nut.

Las medidas son aproximadas con la tuerca de unión apretada.

Dichtungsmaterial: FKM (andere Werkstoffe auf Anfrage)

Sealing material: FKM (other materials on request)

Material de junta tórica: FKM (otros materiales bajo demanda)

D1=Rohr außen-Ø
M1=metrisches Anschlußgewinde

D1=tube outside diameter
M1=metric connecting thread

D1=Ø exterior del tubo
M1=rosca métrica conexión

Einstellbare Winkelstutzen mit Schaft

schaftseitig vormontiert

Adjustable standpipe elbow connectors

pre-assembled on standpipe side

Cuerpos angulares ajustables con vástago

premontado en lado de vástago

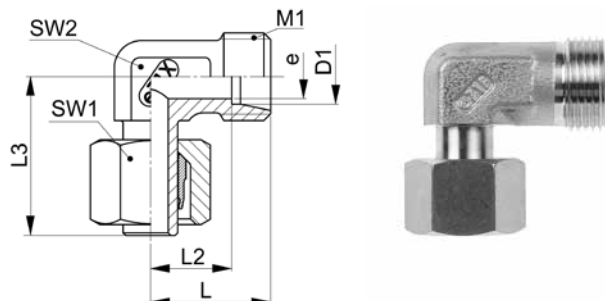

XEWV-..L/S M

Type-D1	Mat.-Nr.	PN	M1	L	L2	L3	SW1	SW2	e	g/Stk
XEWV-06L M	707.2623.060.20	500	12x1.5	19.0	12.0	26.0	14	12	3.4	28
XEWV-08L M	707.2623.080.20	500	14x1.5	21.0	14.0	27.5	17	12	5.0	37
XEWV-10L M	707.2623.100.20	500	16x1.5	22.0	15.0	29.0	19	14	6.5	50
XEWV-12L M	707.2623.120.20	400	18x1.5	24.0	17.0	29.5	22	17	8.0	67
XEWV-15L M	707.2623.150.20	400	22x1.5	28.0	21.0	32.5	27	19	10.0	115
XEWV-18L M	707.2623.180.20	400	26x1.5	31.0	23.5	35.5	32	24	13.0	173
XEWV-22L M	707.2623.220.20	250	30x2.0	35.0	27.5	38.5	36	27	16.0	229
XEWV-28L M	707.2623.280.20	250	36x2.0	38.0	30.5	41.5	41	36	22.0	349
XEWV-35L M	707.2623.350.20	250	45x2.0	45.0	34.5	51.0	50	41	28.0	535
XEWV-42L M	707.2623.420.20	250	52x2.0	51.0	40.0	56.0	60	50	34.0	813
XEWV-06S M	707.2623.060.30	800	14x1.5	23.0	16.0	27.0	17	12	3.4	42
XEWV-08S M	707.2623.080.30	800	16x1.5	24.0	17.0	27.5	19	14	4.3	57
XEWV-10S M	707.2623.100.30	800	18x1.5	25.0	17.5	30.0	22	17	6.0	82
XEWV-12S M	707.2623.120.30	630	20x1.5	29.0	21.5	31.0	24	17	7.0	97
XEWV-14S M	707.2623.140.30	630	22x1.5	30.0	22.0	35.0	27	19	9.0	138
XEWV-16S M	707.2623.160.30	630	24x1.5	33.0	24.5	36.5	30	24	10.5	190
XEWV-20S M	707.2623.200.30	420	30x2.0	37.0	26.5	44.5	36	27	14.0	285
XEWV-25S M	707.2623.250.30	420	36x2.0	42.0	30.0	50.0	46	36	17.0	565
XEWV-30S M	707.2623.300.30	420	42x2.0	49.0	35.5	55.0	50	41	22.0	737
XEWV-38S M	707.2623.380.30	420	52x2.0	57.0	41.0	63.0	60	50	28.0	1155

Achtung: Für Endmontage des vormontierten Schaftes Überwurfmutter mit 1/4 Umdrehung über den Punkt des deutlich fühlbaren Kraftanstiegs anziehen.

For final assembly of the pre-assembled standpipe, tighten the union nut by 1/4 turn beyond the point of the clearly perceptible increase in force.

Atención: Para el ensamblaje final del vástago premontado, apriete la tuerca de unión 1/4 de vuelta más allá del punto del aumento claramente perceptible de la resistencia.

D1=Rohr außen-Ø
M1=metrisches Anschlußgewinde
e=kleinster Innen-Ø

D1=tube outside diameter
M1=metric connecting thread
e=minimum inside diameter

D1=Ø exterior del tubo
M1=rosca métrica conexión
e=Ø interior mínimo

Einstellbare Winkelverschraubungen mit Schaft
Adjustable standpipe elbow fittings
Racores angulares ajustables con vástago

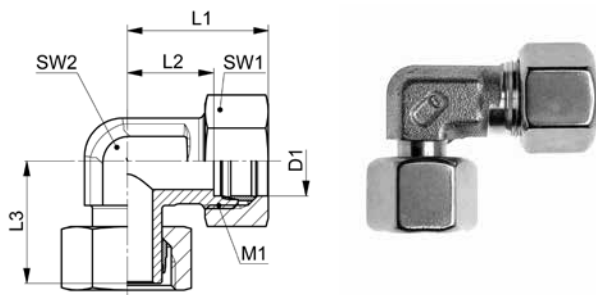

10

EWV-..L/S

Type -D1	Mat.-Nr.	PN	M1	L1	L2	L3	SW1	SW2	g/Stk
EWV-06L	708.2620.060.20	500	12x1.5	27.0	12.0	26.0	14	12	35
EWV-08L	708.2620.080.20	500	14x1.5	29.0	14.0	27.5	17	12	54
EWV-10L	708.2620.100.20	500	16x1.5	30.0	15.0	29.0	19	14	68
EWV-12L	708.2620.120.20	400	18x1.5	32.0	17.0	29.5	22	17	95
EWV-15L	708.2620.150.20	400	22x1.5	36.0	21.0	32.5	27	19	170
EWV-18L	708.2620.180.20	400	26x1.5	40.0	23.5	35.5	32	24	250
EWV-22L	708.2620.220.20	250	30x2.0	44.0	27.5	38.5	36	27	335
EWV-28L	708.2620.280.20	250	36x2.0	47.0	30.5	41.5	41	36	475
EWV-35L	708.2620.350.20	250	45x2.0	56.0	34.5	51.0	50	41	700
EWV-42L	708.2620.420.20	250	52x2.0	63.0	40.0	56.0	60	50	1071
EWV-06S	708.2620.060.30	800	14x1.5	31.0	16.0	27.0	17	12	62
EWV-08S	708.2620.080.30	800	16x1.5	32.0	17.0	27.5	19	14	90
EWV-10S	708.2620.100.30	800	18x1.5	34.0	17.5	30.0	22	17	123
EWV-12S	708.2620.120.30	630	20x1.5	38.0	21.5	31.0	24	17	140
EWV-14S	708.2620.140.30	630	22x1.5	40.0	22.0	35.0	27	19	200
EWV-16S	708.2620.160.30	630	24x1.5	43.0	24.5	36.5	30	24	248
EWV-20S	708.2620.200.30	420	30x2.0	48.0	26.5	44.5	36	27	432
EWV-25S	708.2620.250.30	420	36x2.0	54.0	30.0	50.0	46	36	784
EWV-30S	708.2620.300.30	420	42x2.0	62.0	35.5	55.0	50	41	996
EWV-38S	708.2620.380.30	420	52x2.0	72.0	41.0	63.0	60	50	1530

Baumaße sind Ungefährmaße bei angezogener Überwurfmutter.

Sizes are approximate dimensions at tightened nut.

Las medidas son aproximadas con la tuerca de unión apretada.

Achtung: Für Endmontage des vormontierten Schaftes Überwurfmutter mit 1/4 Umdrehung über den Punkt des deutlich fühlbaren Kraftanstiegs anziehen.

Attention: For final assembly of the pre-assembled standpipe, tighten the union nut by 1/4 turn beyond the point of the clearly perceptible increase in force.

Atención: Para el ensamblaje final del vástago premontado, apriete la tuerca de unión 1/4 de vuelta más allá del punto del aumento claramente perceptible de la resistencia.

D1=Rohr außen-Ø
M1=metrisches Anschlußgewinde

D1=tube outside diameter
M1=metric connecting thread

D1=Ø exterior del tubo
M1=rosca métrica conexión

Einstellbare Winkel-Einschraubverschraubungen mit Schaft

mit Einschraubstutzen, Abdichtung durch Dichtkante Form B nach DIN 3852-2

Adjustable male adaptor standpipe elbow fittings

with male adaptor connector, sealing edge form B acc. DIN 3852-2

Racores angulares para roscar ajustables con vástago

con racor para roscar, cierre hermético mediante borde de obturación forma B según DIN 3852-2

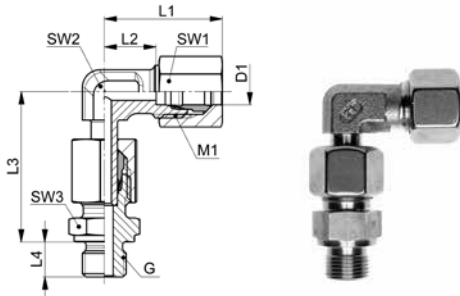

EWV-..LR/SR

Type-D1 G	Mat.-Nr.	PN	G	M1	L1	L2	L3	L4	SW1	SW2	SW3	g/Stk
G=Rohrgewinde (zylindrisch)		G=BSP thread (parallel)				G=rosca de conexión (cilíndrica)						
EWV-06LR 1.8	708.2621.100.20	500	1/8	12x1.5	27.0	12.0	34.5	8.0	14	12	14	57
EWV-08LR 1.4	708.2621.170.20	500	1/4	14x1.5	29.0	14.0	37.5	12.0	17	12	19	82
EWV-10LR 1.4	708.2621.270.20	500	1/4	16x1.5	30.0	15.0	40.0	12.0	19	14	19	96
EWV-12LR 1.4	708.2621.380.20	400	1/4	18x1.5	32.0	17.0	41.5	12.0	22	17	19	126
EWV-12LR 3.8	708.2621.390.20	400	3/8	18x1.5	32.0	17.0	42.0	12.0	22	17	22	134
EWV-12LR 1.2	708.2621.400.20	400	1/2	18x1.5	32.0	17.0	42.5	14.0	22	17	27	164
EWV-15LR 1.2	708.2621.534.20	400	1/2	22x1.5	36.0	21.0	46.5	14.0	27	19	27	229
EWV-18LR 1.2	708.2621.646.20	400	1/2	26x1.5	40.0	23.5	50.0	14.0	32	24	27	305
EWV-22LR 3.4	708.2621.768.20	250	3/4	30x2.0	44.0	27.5	55.0	16.0	36	27	32	415
EWV-28LR 1.1	708.2621.850.20	250	1	36x2.0	47.0	30.5	59.0	18.0	41	36	41	614
EWV-35LR 5.4	708.2621.944.20	250	1 1/4	45x2.0	56.0	34.5	68.5	20.0	50	41	50	984
EWV-42LR 3.2	708.2621.992.20	250	1 1/2	52x2.0	63.0	40.0	75.0	22.0	60	50	55	1417
EWV-06SR 1.4	708.2621.110.30	800	1/4	14x1.5	31.0	16.0	40.0	12.0	17	12	19	99
EWV-08SR 1.4	708.2621.170.30	800	1/4	16x1.5	32.0	17.0	42.5	12.0	19	14	19	121
EWV-10SR 3.8	708.2621.280.30	800	3/8	18x1.5	34.0	17.5	42.5	12.0	22	17	22	169
EWV-12SR 3.8	708.2621.390.30	630	3/8	20x1.5	38.0	21.5	48.5	12.0	24	17	22	222
EWV-12SR 1.2	708.2621.400.30	630	1/2	20x1.5	38.0	21.5	49.0	14.0	24	17	27	234
EWV-14SR 1.2	708.2621.504.30	630	1/2	22x1.5	40.0	22.0	49.0	14.0	27	19	27	287
EWV-16SR 1.2	708.2621.566.30	630	1/2	24x1.5	43.0	24.5	54.5	14.0	30	24	27	339
EWV-20SR 3.4	708.2621.708.30	420	3/4	30x2.0	48.0	26.5	65.0	16.0	36	27	32	551
EWV-25SR 1.1	708.2621.810.30	420	1	36x2.0	54.0	30.0	70.0	16.0	46	36	32	1054
EWV-30SR 5.4	708.2621.902.30	420	1 1/4	42x2.0	62.0	35.5	78.5	20.0	50	41	50	1398
EWV-38SR 3.2	708.2621.953.30	420	1 1/2	52x2.0	72.0	41.0	82.5	22.0	60	50	55	1987

Baumaße sind Ungefährmaße bei angezogener Überwurfmutter.

Sizes are approximate dimensions at tightened nut.

Las medidas son aproximadas con la tuerca de unión apretada.

Achtung: Für Endmontage des vormontierten Schaftes Überwurfmutter mit 1/4 Umdrehung über den Punkt des deutlich fühlbaren Kraftanstiegs anziehen.

Attention: For final assembly of the pre-assembled standpipe, tighten the union nut by 1/4 turn beyond the point of the clearly perceptible increase in force.

Atención: Para el ensamblaje final del vástago premontado, apriete la tuerca de unión 1/4 de vuelta más allá del punto del aumento claramente perceptible de la resistencia.

Einstellbare Winkel-Einschraubverschraubungen

Für eine einstellbare Winkel-Einschraubverschraubung kombinieren wir die einstellbare Winkelverschraubung mit Schaft EWV-..L/S bzw. die einstellbare Winkelverschraubung mit Dichtkegel EWKO-..L/S mit einem geraden Einschraubstutzen.

EWV-..L/S + XGEV-..LR/SR = EWV-..LR/SR
EWKO-..L/S + XGEV-..LR/SR = EWKO-..LR/SR

Weitere Kombinationen sind möglich:

Adjustable male adaptor elbow fittings

For an adjustable male adaptor elbow fitting we combine the adjustable standpipe elbow fitting EWV-..L/S or the adjustable elbow fitting with taper EWKO-..L/S with a straight male adaptor union.

EWV-..L/S + XGEV-..LR/SR = EWV-..LR/SR
EWKO-..L/S + XGEV-..LR/SR = EWKO-..LR/SR

Other combinations are possible:

Racores para roscar angulares ajustables

Para obtener un racor para roscar angular ajustable combinamos el racor angular ajustable con vástago EWV-..L/S o el racor angular ajustable con junta cónica EWKO-..L/S con un racor para roscar recto.

EWV-..L/S + XGEV-..LR/SR = EWV-..LR/SR
EWKO-..L/S + XGEV-..LR/SR = EWKO-..LR/SR

Son posibles otras combinaciones:

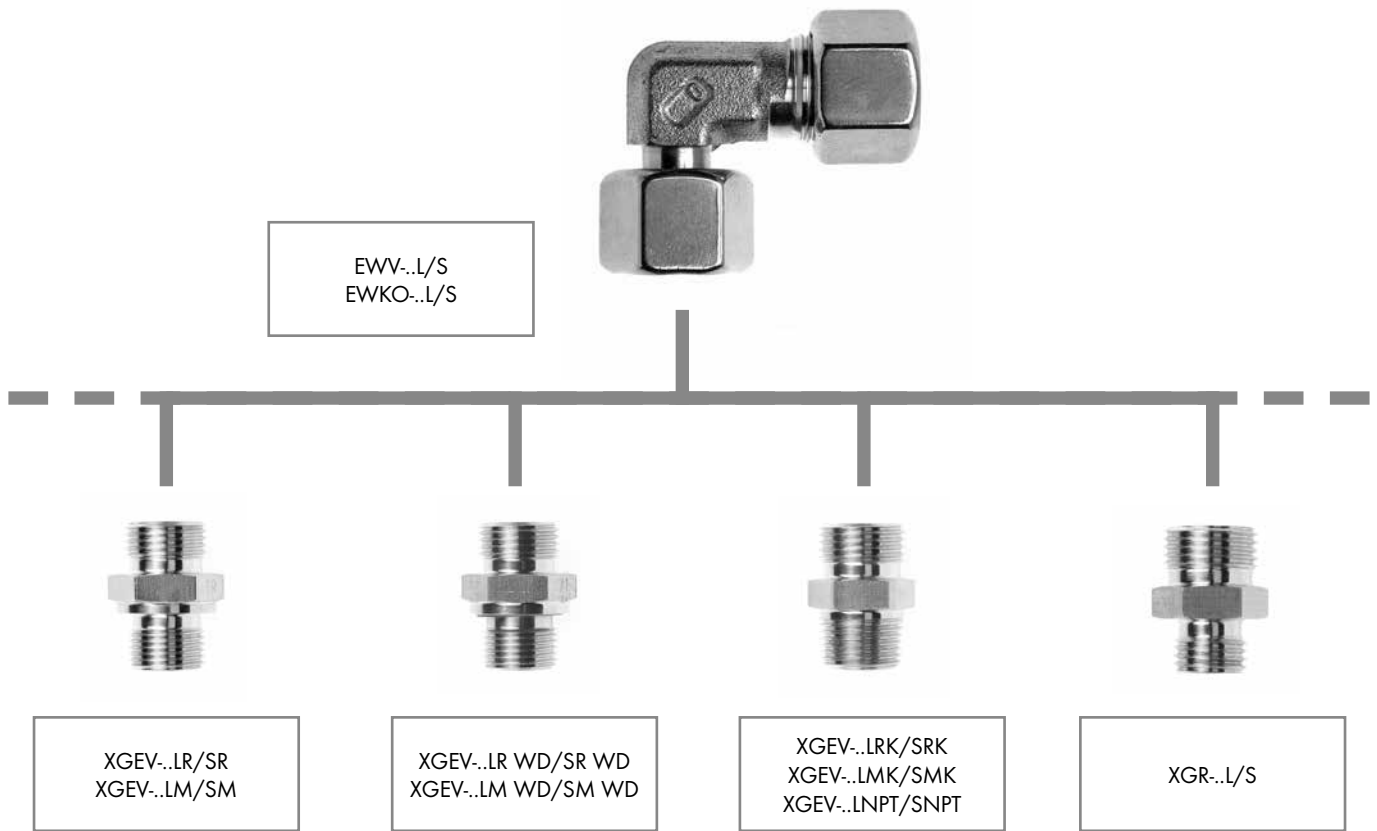

Kombination mit

- XGEV-..LR/SR, XGEV-..LM/SM für zylindrische Einschraubgewinde (zöllig bzw. metrisch) mit Abdichtung durch Dichtkante Form B nach DIN 3852-2
- XGEV-..LR WD/SR WD, XGEV-..LM WD/SM WD für zylindrische Einschraubgewinde (zöllig bzw. metrisch) mit Abdichtung durch Profildichtring Form E nach DIN 3852-11
- XGEV-..LRK/SRK, XGEV-..LMK/SMK, XGEV-..LNPT/SNPT für konische Einschraubgewinde (zöllig bzw. metrisch) mit Abdichtung im Kegelfgewinde Form C nach DIN 3852-2
- XGR-..L/S für den Übergang auf andere Anschlussgrößen

Das EXMAR Team steht Ihnen für Ihre Fragen gern zur Verfügung.

Combination with

- XGEV-..LR/SR, XGEV-..LM/SM for parallel male adaptor threads (English or metric) with sealing through seal edge form B acc. to DIN 3852-2
- XGEV-..LR WD/SR WD, XGEV-..LM WD/SM WD for parallel male adaptor threads (English or metric) with sealing through profile seal ring form E acc. to DIN 3852-11
- XGEV-..LRK/SRK, XGEV-..LMK/SMK, XGEV-..LNPT/SNPT for tapered male adaptor threads (English or metric) with taper thread sealing form C acc. to DIN 3852-2
- XGR-..L/S for transitioning to other connection sizes

The EXMAR Team would be glad to assist you with your questions.

Combinación con

- XGEV-..LR/SR, XGEV-..LM/SM para rosca de conexión cilíndrica (inglesa o métrica) con cierre hermético mediante junta de obturación según DIN 3852-2
- XGEV-..LR WD/SR WD, XGEV-..LM WD/SM WD para rosca de conexión cilíndrica (inglesa o métrica) con cierre hermético mediante junta anular de perfil, forma E según DIN 3852-11
- XGEV-..LRK/SRK, XGEV-..LMK/SMK, XGEV-..LNPT/SNPT para rosca de conexión cónica (inglesa o métrica) con cierre hermético mediante rosca cónica, forma C según DIN 3852-2
- XGR-..L/S para la transición a otros tamaños de conexión

El equipo de EXMAR está a su disposición para responder a sus consultas.

Einstellbare Winkel-Einschraubstutzen

mit Kontermutter, Abdichtung durch gekammerten O-Ring, ISO 1179-3

Adjustable male adaptor elbow connectors

with counter nut, sealing with restraining O-ring, ISO 1179-3

Cuerpos para roscar en codo ajustables

con contratueras, cierre hermético mediante junta tórica protegida, ISO 1179-3

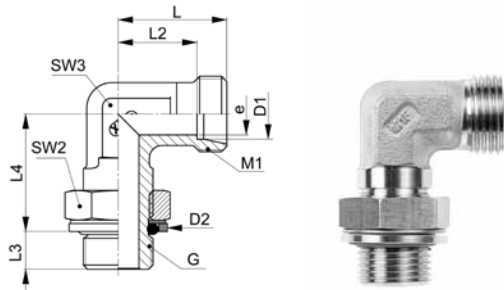

XWEE-..LR

Type-D1 G	Mat.-Nr.	PN	G	M1	D2	L	L2	L3	L4	SW2	SW3	e	g/Stk
G=Rohrgewinde (zylindrisch)		G=BSP thread (parallel)											

Dichtungsmaterial: FKM (andere Werkstoffe auf Anfrage)

Sealing material: FKM (other materials on request)

Material de junta tórica: FKM (otros materiales bajo demanda).

Konterscheibe aus Edelstahl 1.4404 / AISI 316L

Counter nut made of stainless steel 1.4404 / AISI 316L

Contratuerca hecho de acero inoxidable 1.4404 / AISI 316L

1 - Höhenunterschied

2 - Einschraubwinkel, 1.4571 / AISI 316 Ti

3 - Kontermutter, 1.4571 / AISI 316 Ti

4 - Konterscheibe, 1.4301 / AISI 304

5 - Kammerring, 1.4571 / AISI 316 Ti

6 - O-Ring, FKM

1 - Difference in height

2 - Male adaptor elbow, 1.4571 / AISI 316 Ti

3 - Counter nut, 1.4571 / AISI 316 Ti

4 - Locking washer, 1.4301 / AISI 304

5 - Restraining ring, 1.4571 / AISI 316 Ti

6 - O-ring, FKM

1 - Diferencia de altura

2 - Junta roscada en ángulo, 1.4571 / AISI 316 Ti

3 - Contratuerca, 1.4571 / AISI 316 Ti

4 - Arandela de sujeción, 1.4301 / AISI 304

5 - Anillo retentivo, 1.4571 / AISI 316 Ti

6 - O-ring, FKM

D1=Rohr außen-Ø
M1=metrisches Anschlußgewinde
e=kleinster Innen-Ø

D1=tube outside diameter
M1=metric connecting thread
e=minimum inside diameter

D1=Ø exterior del tubo
M1=rosca métrica conexión
e=Ø interior mínimo

Einstellbare Winkel-Einschraubverschraubungen

mit Kontermutter, Abdichtung durch gekammerten O-Ring, ISO 1179-3

Adjustable male adaptor elbow fittings

with counter nut, sealing with restraining O-ring, ISO 1179-3

Racores para roscar en codo ajustables

con contratueras, cierre hermético mediante junta tórica protegida, ISO 1179-3

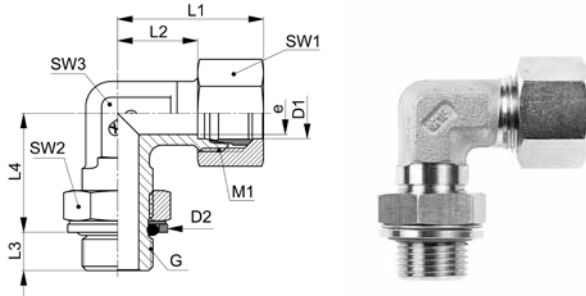

WEE-..LR

Type-D1 G	Mat.-Nr.	PN	G	M1	D2	L1	L2	L3	L4	SW1	SW2	SW3	g/Stk
G=Rohrgewinde (zylindrisch)		G=BSP thread (parallel)											

Baumaße sind Ungefährmaße bei angezogener Überwurfmutter.

Sizes are approximate dimensions at tightened nut.

Las medidas son aproximadas con la tuerca de unión apretada.

Dichtungsmaterial: FKM (andere Werkstoffe auf Anfrage)

Sealing material: FKM (other materials on request)

Material de junta tórica: FKM (otros materiales bajo demanda).

Konterscheibe aus Edelstahl 1.4404 / AISI 316L

Counter nut made of stainless steel 1.4404 / AISI 316L

Contratuerca hecho de acero inoxidable 1.4404 / AISI 316L

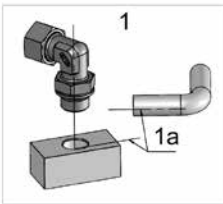
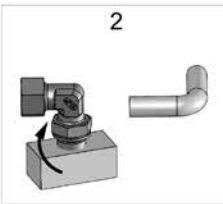
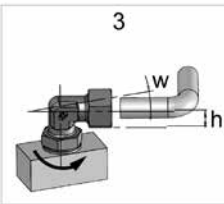
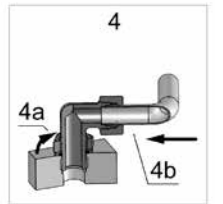
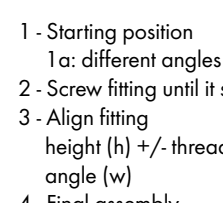
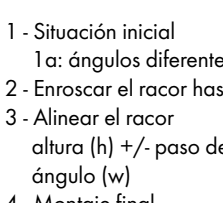
Montageanleitung	Installation instruction	Instrucción de montaje
 <p>1 - Ausgangslage 1a: abweichende Winkel</p>	 <p>1 - Starting position 1a: different angles</p>	 <p>1 - Situación inicial 1a: ángulos diferentes</p>
 <p>2 - Verschraubung bis zum Anschlag einschrauben</p> <p>3 - Verschraubung ausrichten Höhe (h) +/- Gewindesteigung Winkel (w)</p> <p>4 - Fertigmontage 4a: Kontermutter anziehen 4b: Rohr montieren</p>	 <p>2 - Screw fitting until it stops</p> <p>3 - Align fitting height (h) +/- thread pitch angle (w)</p> <p>4 - Final assembly 4a: Tighten counter nut 4b: Install tube</p>	 <p>2 - Enrosar el racor hasta que se detenga</p> <p>3 - Alinear el racor altura (h) +/- paso de rosca ángulo (w)</p> <p>4 - Montaje final 4a: Apriete contratuerca 4b: Instalar tubo</p>

D1=Rohr außen-Ø
M1=metrisches Anschlußgewinde

D1=tube outside diameter
M1=metric connecting thread

D1=Ø exterior del tubo
M1=rosca métrica conexión

Einstellbare Winkel-Einschraubstutzen

mit Kontermutter, Abdichtung durch gekammerten O-Ring, ISO 1179-3

Adjustable male adaptor elbow connectors

with counter nut, sealing with restraining O-ring, ISO 1179-3

Cuerpos para roscar en codo ajustables

con contratueras, cierre hermético mediante junta tórica protegida, ISO 1179-3

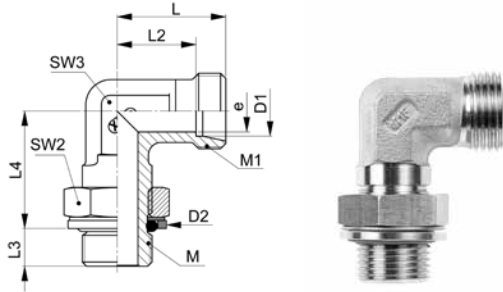

XWEE..LM

Type-D1 M	Mat.-Nr.	PN	M	M1	D2	L	L2	L3	L4	SW2	SW3	e	g/Stk
M=metrisches Gewinde (zylindrisch)		M=metric thread (parallel)											
XWEE-10LM14x1,5	707.2408.280.20	200	14x1.5	16x1.5	19.5	22.0	15.0	10.0	24.0	19	14	7.5	56
XWEE-18LM22x1,5	707.2408.460.20	200	22x1.5	26x1.5	28.5	31.0	24.0	12.0	33.0	27	24	14.0	164

Dichtungsmaterial: FKM (andere Werkstoffe auf Anfrage)

Sealing material: FKM (other materials on request)

Material de junta tórica: FKM (otros materiales bajo demanda).

Konterscheibe aus Edelstahl 1.4404 / AISI 316L

Counter nut made of stainless steel 1.4404 / AISI 316L

Contratuerca hecho de acero inoxidable 1.4404 / AISI 316L

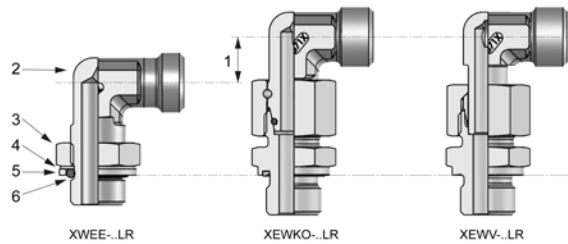

- 1 - Höhenunterschied
- 2 - Einschraubwinkel, 1.4571 / AISI 316 Ti
- 3 - Kontermutter, 1.4571 / AISI 316 Ti
- 4 - Konterscheibe, 1.4301 / AISI 304
- 5 - Kammerring, 1.4571 / AISI 316 Ti
- 6 - O-Ring, FKM

- 1 - Difference in height
- 2 - Male adaptor elbow, 1.4571 / AISI 316 Ti
- 3 - Counter nut, 1.4571 / AISI 316 Ti
- 4 - Locking washer, 1.4301 / AISI 304
- 5 - Restraining ring, 1.4571 / AISI 316 Ti
- 6 - O-ring, FKM

- 1 - Diferencia de altura
- 2 - Junta roscada en ángulo, 1.4571 / AISI 316 Ti
- 3 - Contratuerca, 1.4571 / AISI 316 Ti
- 4 - Arandela de sujeción, 1.4301 / AISI 304
- 5 - Anillo retentivo, 1.4571 / AISI 316 Ti
- 6 - O-ring, FKM

D1=Rohr außen-Ø
M1=metrisches Anschlußgewinde
e=kleinster Innen-Ø

D1=tube outside diameter
M1=metric connecting thread
e=minimum inside diameter

D1=Ø exterior del tubo
M1=rosca métrica conexión
e=Ø interior mínimo

Einstellbare Winkel-Einschraubverschraubungen

mit Kontermutter, Abdichtung durch gekammerten O-Ring, ISO 1179-3

Adjustable male adaptor elbow fittings

with counter nut, sealing with restraining O-ring, ISO 1179-3

Racores para roscar en codo ajustables

con contratueras, cierre hermético mediante junta tórica protegida, ISO 1179-3

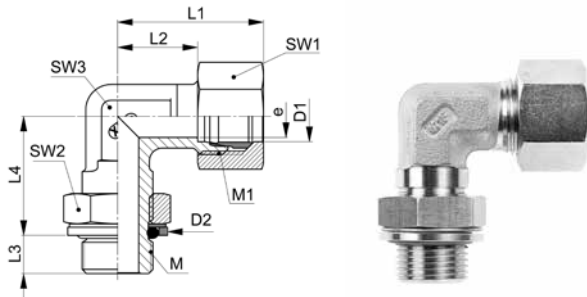

WEE-..LM

Type-D1 M	Mat.-Nr.	PN	M	M1	D2	L1	L2	L3	L4	SW1	SW2	SW3	g/Stk
M=metrisches Gewinde (zylindrisch)		M=metric thread (parallel)											
													M=rosca métrica (cilíndrica)
WEE-10LM 14x1,5	708.2408.280.20	200	14x1.5	16x1.5	19.5	30.5	15.0	10.0	24.0	19	19	14	79
WEE-18LM 22x1,5	708.2408.460.20	200	22x1.5	26x1.5	28.5	40.5	24.0	12.0	33.0	32	27	24	236

Baumaße sind Ungefährmaße bei angezogener Überwurfmutter.

Sizes are approximate dimensions at tightened nut.

Las medidas son aproximadas con la tuerca de unión apretada.

Dichtungsmaterial: FKM (andere Werkstoffe auf Anfrage)

Sealing material: FKM (other materials on request)

Material de junta tórica: FKM (otros materiales bajo demanda).

Konterscheibe aus Edelstahl 1.4404 / AISI 316L

Counter nut made of stainless steel 1.4404 / AISI 316L

Contratuerca hecho de acero inoxidable 1.4404 / AISI 316L

Montageanleitung

Installation instruction

Instrucción de montaje

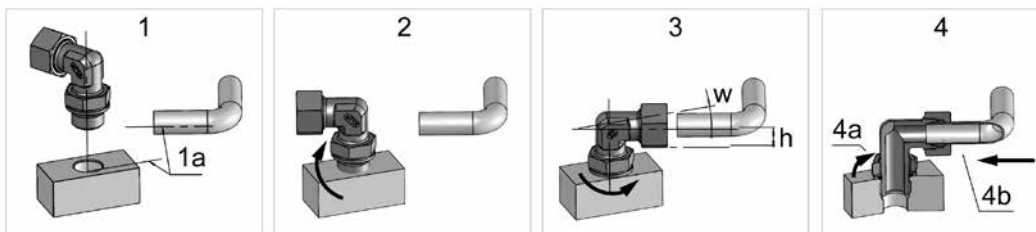

- 1 - Ausgangslage
1a: abweichende Winkel
- 2 - Verschraubung bis zum Anschlag einschrauben
- 3 - Verschraubung ausrichten
Höhe (h) +/- Gewindesteigung
Winkel (w)
- 4 - Fertigmontage
4a: Kontermutter anziehen
4b: Rohr montieren

- 1 - Starting position
1a: different angles
- 2 - Screw fitting until it stops
- 3 - Align fitting
height (h) +/- thread pitch angle (w)
- 4 - Final assembly
4a: Tighten counter nut
4b: Install tube

- 1 - Situación inicial
1a: ángulos diferentes
- 2 - Enroscar el racor hasta que se detenga
- 3 - Alinear el racor
altura (h) +/- paso de rosca ángulo (w)
- 4 - Montaje final
4a: Apriete contratuerca
4b: Instalar tubo

D1=Rohr außen-Ø
M1=metrisches Anschlußgewinde

D1=tube outside diameter
M1=metric connecting thread

D1=Ø exterior del tubo
M1=rosca métrica conexión

Einstellbare T-Stutzen mit Dichtkegel und O-Ring

dichtkegelseitig vormontiert

Adjustable T connectors with taper and O-ring

pre-assembled on tapered nipple side

Cuerpos T ajustables con junta cónica y junta tórica

premontado en lado de junta cónica

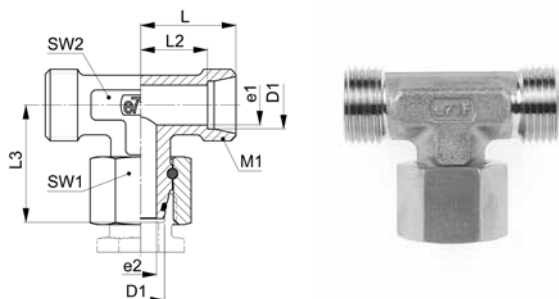

XETKO-..L/S M

Type-D1	Mat.-Nr.	PN	M1	L	L2	L3	SW1	SW2	e1	e2	g/Stk
XETKO-06L M	707.3670.060.20	315	12x1.5	19.0	12.0	26.0	14	12	4.0	3.0	44
XETKO-08L M	707.3670.080.20	315	14x1.5	21.0	14.0	27.5	17	12	6.0	4.0	57
XETKO-10L M	707.3670.100.20	315	16x1.5	22.0	15.0	29.0	19	14	8.0	6.0	72
XETKO-12L M	707.3670.120.20	315	18x1.5	24.0	17.0	29.5	22	17	10.0	8.0	94
XETKO-15L M	707.3670.150.20	315	22x1.5	28.0	21.0	32.5	27	19	12.0	10.0	163
XETKO-18L M	707.3670.180.20	315	26x1.5	31.0	23.5	35.5	32	24	15.0	13.0	218
XETKO-22L M	707.3670.220.20	160	30x2.0	35.0	27.5	38.5	36	27	19.0	17.0	306
XETKO-28L M	707.3670.280.20	160	36x2.0	38.0	30.5	41.5	41	36	24.0	22.0	461
XETKO-35L M	707.3670.350.20	160	45x2.0	45.0	34.5	51.0	50	41	30.0	28.0	691
XETKO-42L M	707.3670.420.20	160	52x2.0	51.0	40.0	56.0	60	50	36.0	34.0	1052
XETKO-06S M	707.3670.060.30	630	14x1.5	23.0	16.0	27.0	17	12	4.0	3.0	67
XETKO-08S M	707.3670.080.30	630	16x1.5	24.0	17.0	27.5	19	14	5.0	4.0	88
XETKO-10S M	707.3670.100.30	630	18x1.5	25.0	17.5	30.0	22	17	7.0	6.0	115
XETKO-12S M	707.3670.120.30	630	20x1.5	29.0	21.5	31.0	24	17	8.0	8.0	147
XETKO-14S M	707.3670.140.30	630	22x1.5	30.0	22.0	35.0	27	19	10.0	9.0	190
XETKO-16S M	707.3670.160.30	400	24x1.5	33.0	24.5	36.5	30	24	12.0	11.0	244
XETKO-20S M	707.3670.200.30	400	30x2.0	37.0	26.5	44.5	36	27	16.0	14.0	383
XETKO-25S M	707.3670.250.30	400	36x2.0	42.0	30.0	50.0	46	36	20.0	18.0	685
XETKO-30S M	707.3670.300.30	400	42x2.0	49.0	35.5	55.0	50	41	25.0	23.0	916
XETKO-38S M	707.3670.380.30	315	52x2.0	57.0	41.0	63.0	60	50	32.0	30.0	1383

Dichtungsmaterial: FKM (andere Werkstoffe auf Anfrage)

Sealing material: FKM (other materials on request)

Material de junta tórica: FKM (otros materiales bajo demanda)

ISO 8434-1-SWOBT

D1=Rohr außen-Ø
M1=metrisches Anschlußgewinde
e1/e2=kleinste Innen-Ø

D1=tube outside diameter
M1=metric connecting thread
e1/e2=minimum inside diameters

D1=Ø exterior del tubo
M1=rosca métrica conexión
e1/e2=Ø interiores mínimo

Einstellbare T-Verschraubungen mit Dichtkegel und O-Ring
Adjustable T fittings with taper and O-ring
Racores T ajustables con junta cónica y junta tórica

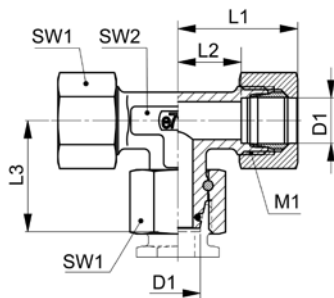

10

ETKO-..L/S

Type -D1	Mat.-Nr.	PN	M1	L1	L2	L3	SW1	SW2	g/Stk
ETKO-06L	708.3670.060.20	315	12x1.5	27.0	12.0	26.0	14	12	54
ETKO-08L	708.3670.080.20	315	14x1.5	29.0	14.0	27.5	17	12	76
ETKO-10L	708.3670.100.20	315	16x1.5	30.5	15.0	29.0	19	14	107
ETKO-12L	708.3670.120.20	315	18x1.5	32.5	17.0	29.5	22	17	135
ETKO-15L	708.3670.150.20	315	22x1.5	37.0	21.0	32.5	27	19	223
ETKO-18L	708.3670.180.20	315	26x1.5	40.5	23.5	35.5	32	24	332
ETKO-22L	708.3670.220.20	160	30x2.0	44.5	27.5	38.5	36	27	439
ETKO-28L	708.3670.280.20	160	36x2.0	47.5	30.5	41.5	41	36	659
ETKO-35L	708.3670.350.20	160	45x2.0	57.0	34.5	51.0	50	41	915
ETKO-42L	708.3670.420.20	160	52x2.0	63.5	40.0	56.0	60	50	1536
ETKO-06S	708.3670.060.30	630	14x1.5	31.0	16.0	27.0	17	12	87
ETKO-08S	708.3670.080.30	630	16x1.5	32.0	17.0	27.5	19	14	109
ETKO-10S	708.3670.100.30	630	18x1.5	34.5	17.5	30.0	22	17	169
ETKO-12S	708.3670.120.30	630	20x1.5	38.5	21.5	31.0	24	17	212
ETKO-14S	708.3670.140.30	630	22x1.5	40.5	22.0	35.0	27	19	281
ETKO-16S	708.3670.160.30	400	24x1.5	44.0	24.5	36.5	30	24	382
ETKO-20S	708.3670.200.30	400	30x2.0	49.5	26.5	44.5	36	27	542
ETKO-25S	708.3670.250.30	400	36x2.0	55.5	30.0	50.0	46	36	1050
ETKO-30S	708.3670.300.30	400	42x2.0	63.5	35.5	55.0	50	41	1349
ETKO-38S	708.3670.380.30	315	52x2.0	74.0	41.0	63.0	60	50	2061

Baumaße sind Ungefährmaße bei angezogener Überwurfmutter.

Sizes are approximate dimensions at tightened nut.

Las medidas son aproximadas con la tuerca de unión apretada.

Dichtungsmaterial: FKM (andere Werkstoffe auf Anfrage)

Sealing material: FKM (other materials on request)

Material de junta tórica: FKM (otros materiales bajo demanda)

ISO 8434-1-SWOBTC

D1=Rohr außen-Ø
M1=metrisches Anschlußgewinde

D1=tube outside diameter
M1=metric connecting thread

D1=Ø exterior del tubo
M1=rosca métrica conexión

Einstellbare T-Stutzen mit Schaft

schaftseitig vormontiert

Adjustable standpipe T connectors

pre-assembled on standpipe side

Cuerpos T ajustables con vástago

premontado en lado de vástago

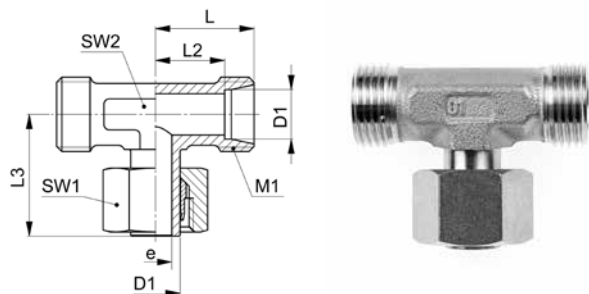

XETV-..L/S M

Type-D1	Mat.-Nr.	PN	M1	L	L2	L3	SW1	SW2	e	g/Stk
XETV-06L M	707.3620.060.20	500	12x1.5	19.0	12.0	26.0	14	12	3.0	39
XETV-08L M	707.3620.080.20	500	14x1.5	21.0	14.0	27.5	17	12	5.0	50
XETV-10L M	707.3620.100.20	500	16x1.5	22.0	15.0	29.0	19	14	6.5	68
XETV-12L M	707.3620.120.20	400	18x1.5	24.0	17.0	29.5	22	17	8.0	87
XETV-15L M	707.3620.150.20	400	22x1.5	28.0	21.0	32.5	27	19	10.0	152
XETV-18L M	707.3620.180.20	400	26x1.5	31.0	23.5	35.5	32	24	13.0	213
XETV-22L M	707.3620.220.20	250	30x2.0	35.0	27.5	38.5	36	27	16.0	306
XETV-28L M	707.3620.280.20	250	36x2.0	38.0	30.5	41.5	41	36	22.0	455
XETV-35L M	707.3620.350.20	250	45x2.0	45.0	34.5	51.0	50	41	28.0	679
XETV-42L M	707.3620.420.20	250	52x2.0	51.0	40.0	56.0	60	50	34.0	1032
XETV-06S M	707.3620.060.30	800	14x1.5	23.0	16.0	27.0	17	12	3.0	62
XETV-08S M	707.3620.080.30	800	16x1.5	24.0	17.0	27.5	19	14	4.0	80
XETV-10S M	707.3620.100.30	800	18x1.5	25.0	17.5	30.0	22	17	6.0	109
XETV-12S M	707.3620.120.30	630	20x1.5	29.0	21.5	31.0	24	17	7.0	142
XETV-14S M	707.3620.140.30	630	22x1.5	30.0	22.0	35.0	27	19	9.0	184
XETV-16S M	707.3620.160.30	630	24x1.5	33.0	24.5	36.5	30	24	10.5	241
XETV-20S M	707.3620.200.30	420	30x2.0	37.0	26.5	44.5	36	27	14.0	376
XETV-25S M	707.3620.250.30	420	36x2.0	42.0	30.0	50.0	46	36	17.0	699
XETV-30S M	707.3620.300.30	420	42x2.0	49.0	35.5	55.0	50	41	22.0	937
XETV-38S M	707.3620.380.30	420	52x2.0	57.0	41.0	63.0	60	50	27.0	1005

Achtung: Für Endmontage des vormontierten Schaftes Überwurfmutter mit 1/4 Umdrehung über den Punkt des deutlich fühlbaren Kraftanstiegs anziehen.

For final assembly of the pre-assembled standpipe, tighten the union nut by 1/4 turn beyond the point of the clearly perceptible increase in force.

Atención: Para el ensamblaje final del vástago premontado, apriete la tuerca de unión 1/4 de vuelta más allá del punto del aumento claramente perceptible de la resistencia.

D1=Rohr außen-Ø
M1=metrisches Anschlußgewinde
e=kleinster Innen-Ø

D1=tube outside diameter
M1=metric connecting thread
e=minimum inside diameter

D1=Ø exterior del tubo
M1=rosca métrica conexión
e=Ø interior mínimo

Einstellbare T-Verschraubungen mit Schaft
Adjustable standpipe T fittings
Racores T ajustables con vástago

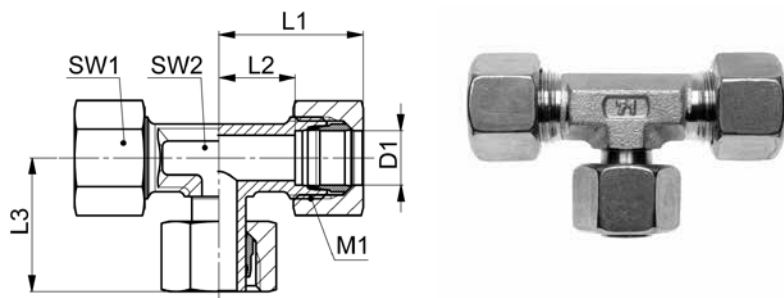

10

ETV-..L/S

Type -D1	Mat.-Nr.	PN	M1	L1	L2	L3	SW1	SW2	g/Stk
ETV-06L	708.3620.060.20	500	12x1.5	27.0	12.0	26.0	14	12	62
ETV-08L	708.3620.080.20	500	14x1.5	29.0	14.0	27.5	17	12	84
ETV-10L	708.3620.100.20	500	16x1.5	30.0	15.0	29.0	19	14	110
ETV-12L	708.3620.120.20	400	18x1.5	32.0	17.0	29.5	22	17	145
ETV-15L	708.3620.150.20	400	22x1.5	36.0	21.0	32.5	27	19	246
ETV-18L	708.3620.180.20	400	26x1.5	40.0	23.5	35.5	32	24	351
ETV-22L	708.3620.220.20	250	30x2.0	44.0	27.5	38.5	36	27	486
ETV-28L	708.3620.280.20	250	36x2.0	47.0	30.5	41.5	41	36	667
ETV-35L	708.3620.350.20	250	45x2.0	56.0	34.5	51.0	50	41	1005
ETV-42L	708.3620.420.20	250	52x2.0	63.0	40.0	56.0	60	50	1539
ETV-06S	708.3620.060.30	800	14x1.5	31.0	16.0	27.0	17	12	100
ETV-08S	708.3620.080.30	800	16x1.5	32.0	17.0	27.5	19	14	125
ETV-10S	708.3620.100.30	800	18x1.5	34.0	17.5	30.0	22	17	176
ETV-12S	708.3620.120.30	630	20x1.5	38.0	21.5	31.0	24	17	217
ETV-14S	708.3620.140.30	630	22x1.5	40.0	22.0	35.0	27	19	298
ETV-16S	708.3620.160.30	630	24x1.5	43.0	24.5	36.5	30	24	382
ETV-20S	708.3620.200.30	420	30x2.0	48.0	26.5	44.5	36	27	602
ETV-25S	708.3620.250.30	420	36x2.0	54.0	30.0	50.0	46	36	1149
ETV-30S	708.3620.300.30	420	42x2.0	62.0	35.5	55.0	50	41	1433
ETV-38S	708.3620.380.30	420	52x2.0	72.0	41.0	63.0	60	50	2187

Baumaße sind Ungefährmaße bei angezogener Überwurfmutter.

Sizes are approximate dimensions at tightened nut.

Las medidas son aproximadas con la tuerca de unión apretada.

Achtung: Für Endmontage des vormontierten Schaftes Überwurfmutter mit 1/4 Umdrehung über den Punkt des deutlich fühlbaren Kraftanstiegs anziehen.

Attention: For final assembly of the pre-assembled standpipe, tighten the union nut by 1/4 turn beyond the point of the clearly perceptible increase in force.

Atención: Para el ensamblaje final del vástago premontado, apriete la tuerca de unión 1/4 de vuelta más allá del punto del aumento claramente perceptible de la resistencia.

D1=Rohr außen-Ø
M1=metrisches Anschlußgewinde

D1=tube outside diameter
M1=metric connecting thread

D1=Ø exterior del tubo
M1=rosca métrica conexión

Einstellbare T-Einschraubverschraubungen mit Schaft

mit Einschraubstutzen, Abdichtung durch Dichtkante Form B nach DIN 3852-2

Adjustable male adaptor standpipe T fittings

with male adaptor connector, sealing edge form B acc. DIN 3852-2

Racores T para roscar ajustables con vástago

con racor para roscar, cierre hermético mediante borde de obturación forma B según DIN 3852-2

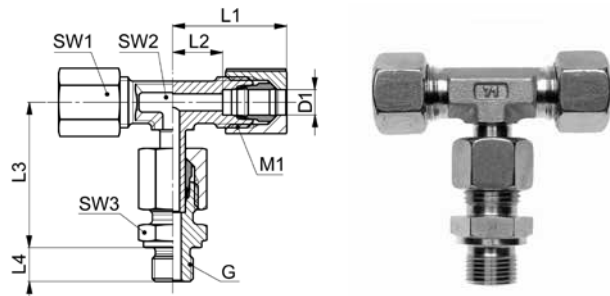

ETV-..LR/SR

Type-D1 G	Mat.-Nr.	PN	G	M1	L1	L2	L3	L4	SW1	SW2	SW3	g/Stk
G=Rohrgewinde (zylindrisch)		G=BSP thread (parallel)			G=rosca de conexión (cilíndrica)							
ETV-06LR 1.8	708.3651.100.20	500	1/8	12x1.5	27.0	12.0	34.5	10.0	14	12	14	71
ETV-08LR 1.4	708.3651.170.20	500	1/4	14x1.5	29.0	14.0	37.5	10.0	17	12	17	106
ETV-10LR 1.4	708.3651.270.20	500	1/4	16x1.5	30.0	14.0	40.0	11.0	19	14	19	128
ETV-12LR 3.8	708.3651.390.20	400	3/8	18x1.5	32.0	17.0	42.0	11.0	22	17	22	175
ETV-15LR 1.2	708.3651.534.20	400	1/2	22x1.5	36.0	21.0	46.5	12.0	27	19	24	291
ETV-18LR 1.2	708.3651.646.20	400	1/2	26x1.5	40.0	23.5	50.0	12.0	32	24	24	427
ETV-22LR 3.4	708.3651.768.20	250	3/4	30x2.0	44.0	27.5	55.0	14.0	36	27	32	568
ETV-28LR 1.1	708.3651.850.20	250	1	36x2.0	47.0	30.5	59.0	14.0	41	36	41	792
ETV-35LR 5.4	708.3651.944.20	250	1 1/4	45x2.0	56.0	34.5	68.5	16.0	50	41	50	1230
ETV-42LR 3.2	708.3651.992.20	250	1 1/2	52x2.0	63.0	40.0	75.0	16.0	60	50	55	1671
ETV-06SR 1.4	708.3651.110.30	800	1/4	14x1.5	31.0	16.0	40.0	12.0	17	12	17	128
ETV-08SR 1.4	708.3651.170.30	800	1/4	16x1.5	32.0	17.0	42.5	12.0	19	14	19	158
ETV-10SR 3.8	708.3651.280.30	800	3/8	18x1.5	34.0	17.5	45.0	12.0	22	17	22	219
ETV-12SR 3.8	708.3651.390.30	630	3/8	20x1.5	38.0	21.5	48.0	12.0	24	17	24	277
ETV-14SR 1.2	708.3651.504.30	630	1/2	22x1.5	40.0	22.0	54.0	14.0	27	19	27	387
ETV-16SR 1.2	708.3651.566.30	630	1/2	24x1.5	43.0	24.5	55.0	14.0	30	24	27	442
ETV-20SR 3.4	708.3651.704.30	420	3/4	30x2.0	48.0	26.5	67.0	16.0	36	27	32	722
ETV-25SR 1.1	708.3651.810.30	420	1	36x2.0	54.0	30.0	73.0	18.0	46	36	41	1428
ETV-30SR 3.2	708.3651.905.30	420	1 1/2	42x2.0	62.0	35.5	81.5	20.0	50	41	50	1731
ETV-38SR 5.4	708.3651.954.30	420	1 1/4	52x2.0	72.0	41.0	89.0	22.0	60	50	55	2624

Baumäße sind Ungefährmaße bei angezogener Überwurfmutter.

Sizes are approximate dimensions at tightened nut.

Las medidas son aproximadas con la tuerca de unión apretada.

Achtung: Für Endmontage des vormontierten Schaftes Überwurfmutter mit 1/4 Umdrehung über den Punkt des deutlich fühlbaren Kraftanstiegs anziehen.

Attention: For final assembly of the pre-assembled standpipe, tighten the union nut by 1/4 turn beyond the point of the clearly perceptible increase in force.

Atención: Para el ensamblaje final del vástago premontado, apriete la tuerca de unión 1/4 de vuelta más allá del punto del aumento claramente perceptible de la resistencia.

D1=Rohr außen-Ø
M1=metrisches Anschlußgewinde

D1=tube outside diameter
M1=metric connecting thread

D1=Ø exterior del tubo
M1=rosca métrica conexión

Einstellbare T-Einschraubverschraubung

Für eine einstellbare T-Einschraubverschraubung kombinieren wir die einstellbare T-Verschraubung mit Schaft ETV...L/S bzw. die einstellbare T-Verschraubung mit Dichtkegel ETKO...L/S mit einem geraden Einschraubstutzen.

ETKO...L/S + XGEV...LR/SR = ETKO...LR/SR
 ETV...L/S + XGEV...LR/SR = ETV...LR/SR

Weitere Kombinationen sind möglich:

Adjustable male adaptor T fittings

For an adjustable male adaptor T fitting we combine the adjustable standpipe T fitting ETV...L/S or the adjustable T fitting with taper ETKO...L/S with a straight male adaptor union.

ETKO...L/S + XGEV...LR/SR = ETKO...LR/SR
 ETV...L/S + XGEV...LR/SR = ETV...LR/SR

Other combinations are possible:

Racores para roscar T ajustables

Para obtener un racor para roscar T ajustable combinamos el racor T ajustable con vástago ETV...L/S o el racor T ajustable con junta cónica ETKO...L/S con un racor para roscar recto.

ETKO...L/S + XGEV...LR/SR = ETKO...LR/SR
 ETV...L/S + XGEV...LR/SR = ETV...LR/SR

Son posibles otras combinaciones:

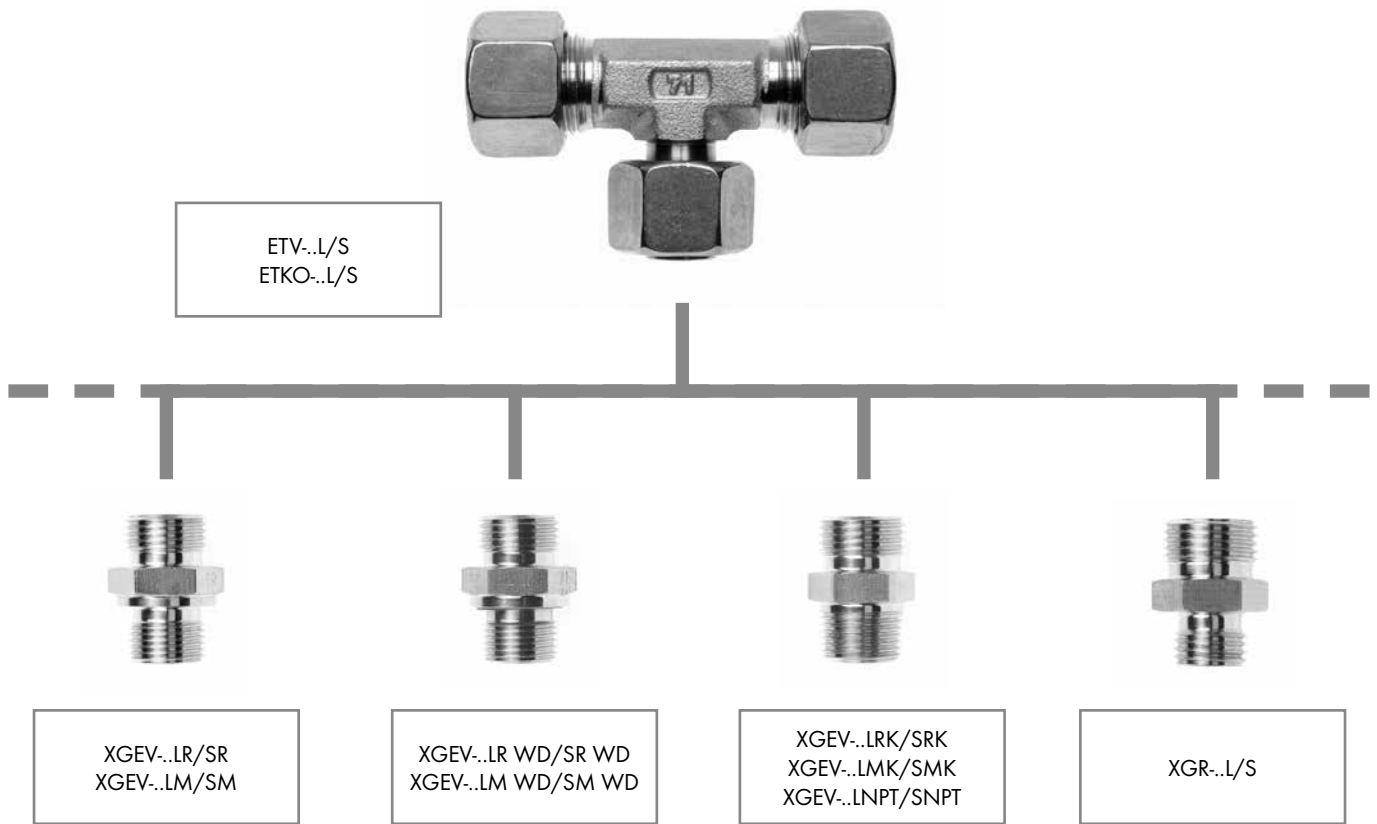

Kombination mit

- XGEV...LR/SR, XGEV...LM/SM für zylindrische Einschraubgewinde (zöllig bzw. metrisch) mit Abdichtung durch Dichtkante Form B nach DIN 3852-2
- XGEV...LR WD/SR WD, XGEV...LM WD/SM WD für zylindrische Einschraubgewinde (zöllig bzw. metrisch) mit Abdichtung durch Profildichtring Form E nach DIN 3852-11
- XGEV...LRK/SRK, XGEV...LMK/SMK, XGEV...LNPT/SNPT für konische Einschraubgewinde (zöllig bzw. metrisch) mit Abdichtung im Kegengewinde Form C nach DIN 3852-2
- XGR...L/S für den Übergang auf andere Anschlussgrößen

Das EXMAR Team steht Ihnen für Ihre Fragen gern zur Verfügung.

Combination with

- XGEV...LR/SR, XGEV...LM/SM for parallel male adaptor threads (English or metric) with sealing through seal edge form B acc. to DIN 3852-2
- XGEV...LR WD/SR WD, XGEV...LM WD/SM WD for parallel male adaptor threads (English or metric) with sealing through profile seal ring form E acc. to DIN 3852-11
- XGEV...LRK/SRK, XGEV...LMK/SMK, XGEV...LNPT/SNPT for tapered male adaptor threads (English or metric) with taper thread sealing form C acc. to DIN 3852-2
- XGR...L/S for transitioning to other connection sizes

The EXMAR Team would be glad to assist you with your questions.

Combinación con

- XGEV...LR/SR, XGEV...LM/SM para rosca de conexión cilíndrica (inglesa o métrica) con cierre hermético mediante junta de obturación según DIN 3852-2
- XGEV...LR WD/SR WD, XGEV...LM WD/SM WD para rosca de conexión cilíndrica (inglesa o métrica) con cierre hermético mediante junta anular de perfil, forma E según DIN 3852-11
- XGEV...LRK/SRK, XGEV...LMK/SMK, XGEV...LNPT/SNPT para rosca de conexión cónica (inglesa o métrica) con cierre hermético mediante rosca cónica, forma C según DIN 3852-2
- XGR...L/S para la transición a otros tamaños de conexión

El equipo de EXMAR está a su disposición para responder a sus consultas.

Einstellbare L-Stutzen mit Dichtkegel und O-Ring

dichtkegelseitig vormontiert

Adjustable L connectors with taper and O-ring

pre-assembled on tapered nipple side

Cuerpos L ajustables con junta cónica y junta tórica

premontado en lado de junta cónica

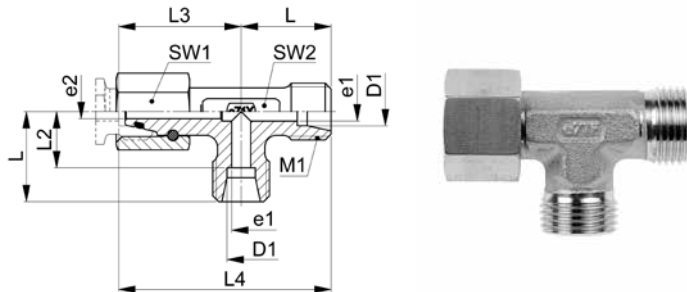

XELKO-..L/S M

Type-D1	Mat.-Nr.	PN	M1	L	L2	L3	L4	SW1	SW2	e1	e2	g/Stk
XELKO-06L M	707.3671.060.20	315	12x1.5	19.0	12.0	26.0	38.0	14	12	4.0	3.0	43
XELKO-08L M	707.3671.080.20	315	14x1.5	21.0	14.0	27.5	41.5	17	12	6.0	4.0	56
XELKO-10L M	707.3671.100.20	315	16x1.5	22.0	15.0	29.0	44.0	19	14	8.0	6.0	71
XELKO-12L M	707.3671.120.20	315	18x1.5	24.0	17.0	29.5	46.5	22	17	10.0	8.0	92
XELKO-15L M	707.3671.150.20	315	22x1.5	28.0	21.0	32.5	53.5	27	19	12.0	10.0	159
XELKO-18L M	707.3671.180.20	315	26x1.5	31.0	23.5	35.5	59.0	32	24	15.0	13.0	221
XELKO-22L M	707.3671.220.20	160	30x2.0	35.0	27.5	38.5	66.0	36	27	19.0	17.0	310
XELKO-28L M	707.3671.280.20	160	36x2.0	38.0	30.5	41.5	72.0	41	36	24.0	22.0	469
XELKO-35L M	707.3671.350.20	160	45x2.0	45.0	34.5	51.0	85.5	50	41	30.0	28.0	700
XELKO-42L M	707.3671.420.20	160	52x2.0	51.0	40.0	56.0	96.0	60	50	36.0	34.0	1047
XELKO-06S M	707.3671.060.30	630	14x1.5	23.0	16.0	27.0	43.0	17	12	4.0	3.0	67
XELKO-08S M	707.3671.080.30	630	16x1.5	24.0	17.0	27.5	44.5	19	14	5.0	4.0	87
XELKO-10S M	707.3671.100.30	630	18x1.5	25.0	17.5	30.0	47.5	22	17	7.0	6.0	116
XELKO-12S M	707.3671.120.30	630	20x1.5	29.0	21.5	31.0	52.5	24	17	8.0	8.0	150
XELKO-14S M	707.3671.140.30	630	22x1.5	30.0	22.0	35.0	57.0	27	19	10.0	9.0	194
XELKO-16S M	707.3671.160.30	400	24x1.5	33.0	24.5	36.5	61.0	30	24	12.0	11.0	251
XELKO-20S M	707.3671.200.30	400	30x2.0	37.0	26.5	44.5	71.0	36	27	16.0	14.0	396
XELKO-25S M	707.3671.250.30	400	36x2.0	42.0	30.0	50.0	80.0	46	36	20.0	18.0	725
XELKO-30S M	707.3671.300.30	400	42x2.0	49.0	35.5	55.0	90.5	50	41	25.0	23.0	974
XELKO-38S M	707.3671.380.30	315	52x2.0	57.0	41.0	63.0	104.0	60	50	32.0	30.0	1496

Dichtungsmaterial: FKM (andere Werkstoffe auf Anfrage)

Sealing material: FKM (other materials on request)

Material de junta tórica: FKM (otros materiales bajo demanda)

ISO 8434-1-SWORT

D1=Rohr außen-Ø
M1=metrisches Anschlußgewinde
e1/e2=kleinste Innen-Ø

D1=tube outside diameter
M1=metric connecting thread
e1/e2=minimum inside diameters

D1=Ø exterior del tubo
M1=rosca métrica conexión
e1/e2=Ø interiores mínimo

Einstellbare L-Verschraubungen mit Dichtkegel und O-Ring
Adjustable L fittings with taper and O-ring
Racores L ajustables con junta cónica y junta tórica

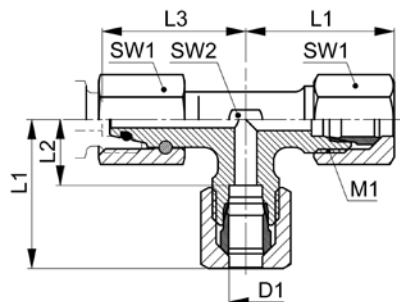

10

ELKO-..L/S

Type -D1	Mat.-Nr.	PN	M1	L1	L2	L3	SW1	SW2	g/Stk
ELKO-06L	708.3671.060.20	315	12x1.5	27.0	12.0	26.0	14	12	53
ELKO-08L	708.3671.080.20	315	14x1.5	29.0	14.0	27.5	17	12	80
ELKO-10L	708.3671.100.20	315	16x1.5	30.0	15.0	29.0	19	14	109
ELKO-12L	708.3671.120.20	315	18x1.5	32.0	17.0	29.5	22	17	132
ELKO-15L	708.3671.150.20	315	22x1.5	36.0	21.0	32.5	27	19	223
ELKO-18L	708.3671.180.20	315	26x1.5	40.0	23.5	35.5	32	24	337
ELKO-22L	708.3671.220.20	160	30x2.0	44.0	27.5	38.5	36	27	439
ELKO-28L	708.3671.280.20	160	36x2.0	47.0	30.5	41.5	41	36	667
ELKO-35L	708.3671.350.20	160	45x2.0	56.0	34.5	51.0	50	41	1004
ELKO-42L	708.3671.420.20	160	52x2.0	63.0	40.0	56.0	60	50	1344
ELKO-06S	708.3671.060.30	630	14x1.5	31.0	16.0	27.0	17	12	89
ELKO-08S	708.3671.080.30	630	16x1.5	32.0	17.0	27.5	19	14	109
ELKO-10S	708.3671.100.30	630	18x1.5	34.0	17.5	30.0	22	17	170
ELKO-12S	708.3671.120.30	630	20x1.5	38.0	21.5	31.0	24	17	212
ELKO-14S	708.3671.140.30	630	22x1.5	40.0	22.0	35.0	27	19	277
ELKO-16S	708.3671.160.30	400	24x1.5	43.0	24.5	36.5	30	24	345
ELKO-20S	708.3671.200.30	400	30x2.0	48.0	26.5	44.5	36	27	548
ELKO-25S	708.3671.250.30	400	36x2.0	54.0	30.0	50.0	46	36	1036
ELKO-30S	708.3671.300.30	400	42x2.0	62.0	35.5	55.0	50	41	1341
ELKO-38S	708.3671.380.30	315	52x2.0	72.0	41.0	63.0	60	50	1964

Baumaße sind Ungefährmaße bei angezogener Überwurfmutter.

Sizes are approximate dimensions at tightened nut.

Las medidas son aproximadas con la tuerca de unión apretada.

Dichtungsmaterial: FKM (andere Werkstoffe auf Anfrage)

Sealing material: FKM (other materials on request)

Material de junta tórica: FKM (otros materiales bajo demanda)

ISO 8434-1-SWORTC

D1=Rohr außen-Ø
M1=metrisches Anschlußgewinde

D1=tube outside diameter
M1=metric connecting thread

D1=Ø exterior del tubo
M1=rosca métrica conexión

Einstellbare L-Stutzen mit Schaft

schaftseitig vormontiert

Adjustable standpipe L connectors

pre-assembled on standpipe side

Cuerpos L ajustables con vástago

premontado en lado de vástago

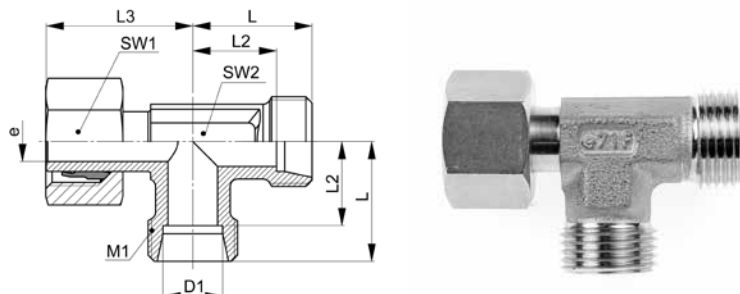

XELV-..L/S M

Type-D1	Mat.-Nr.	PN	M1	L	L2	L3	SW1	SW2	e	g/Stk
XELV-06L M	707.3633.060.20	500	12x1.5	19.0	12.0	26.0	14	12	3.2	40
XELV-08L M	707.3633.080.20	500	14x1.5	21.0	14.0	27.5	17	12	5.0	51
XELV-10L M	707.3633.100.20	500	16x1.5	22.0	15.0	29.0	19	14	6.5	67
XELV-12L M	707.3633.120.20	400	18x1.5	24.0	17.0	29.5	22	17	8.0	87
XELV-15L M	707.3633.150.20	400	22x1.5	28.0	21.0	32.5	27	19	10.0	152
XELV-18L M	707.3633.180.20	400	26x1.5	31.0	23.5	35.5	32	24	13.0	214
XELV-22L M	707.3633.220.20	250	30x2.0	35.0	27.5	38.5	36	27	16.0	307
XELV-28L M	707.3633.280.20	250	36x2.0	38.0	30.5	41.5	41	36	22.0	435
XELV-35L M	707.3633.350.20	250	45x2.0	45.0	34.5	51.0	50	41	28.0	671
XELV-42L M	707.3633.420.20	250	52x2.0	51.0	40.0	56.0	60	50	34.0	1025
XELV-06S M	707.3633.060.30	800	14x1.5	23.0	16.0	27.0	17	12	3.2	62
XELV-08S M	707.3633.080.30	800	16x1.5	24.0	17.0	27.5	19	14	4.3	80
XELV-10S M	707.3633.100.30	800	18x1.5	25.0	17.5	30.0	22	17	6.0	108
XELV-12S M	707.3633.120.30	630	20x1.5	29.0	21.5	31.0	24	17	7.0	143
XELV-14S M	707.3633.140.30	630	22x1.5	30.0	22.0	35.0	27	19	9.0	182
XELV-16S M	707.3633.160.30	630	24x1.5	33.0	24.5	36.5	30	24	10.5	240
XELV-20S M	707.3633.200.30	420	30x2.0	37.0	26.5	44.5	36	27	14.0	377
XELV-25S M	707.3633.250.30	420	36x2.0	42.0	30.0	50.0	46	36	17.0	699
XELV-30S M	707.3633.300.30	420	42x2.0	49.0	35.5	55.0	50	41	22.0	936
XELV-38S M	707.3633.380.30	420	52x2.0	57.0	41.0	63.0	60	50	28.0	1462

Achtung: Für Endmontage des vormontierten Schaftes Überwurfmutter mit 1/4 Umdrehung über den Punkt des deutlich fühlbaren Kraftanstiegs anziehen.

For final assembly of the pre-assembled standpipe, tighten the union nut by 1/4 turn beyond the point of the clearly perceptible increase in force.

Atención: Para el ensamblaje final del vástago premontado, apriete la tuerca de unión 1/4 de vuelta más allá del punto del aumento claramente perceptible de la resistencia.

D1=Rohr außen-Ø
M1=metrisches Anschlußgewinde
e=kleinster Innen-Ø

D1=tube outside diameter
M1=metric connecting thread
e=minimum inside diameter

D1=Ø exterior del tubo
M1=rosca métrica conexión
e=Ø interior mínimo

Einstellbare L-Verschraubungen mit Schaft
Adjustable standpipe L fittings
Racores L ajustables con vástago

10

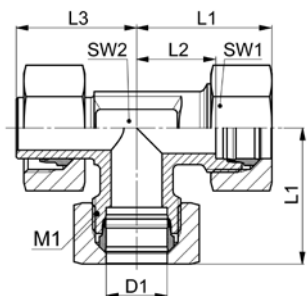

ELV-..L/S

Type -D1	Mat.-Nr.	PN	M1	L1	L2	L3	SW1	SW2	g/Stk
ELV-06L	708.3630.060.20	500	12x1.5	27.0	12.0	26.0	14	12	60
ELV-08L	708.3630.080.20	500	14x1.5	29.0	14.0	27.5	17	12	85
ELV-10L	708.3630.100.20	500	16x1.5	30.0	15.0	29.0	19	14	115
ELV-12L	708.3630.120.20	400	18x1.5	32.0	17.0	29.5	22	17	135
ELV-15L	708.3630.150.20	400	22x1.5	36.0	21.0	32.5	27	19	240
ELV-18L	708.3630.180.20	400	26x1.5	40.0	23.5	35.5	32	24	340
ELV-22L	708.3630.220.20	250	30x2.0	44.0	27.5	38.5	36	27	464
ELV-28L	708.3630.280.20	250	36x2.0	47.0	30.5	41.5	41	36	604
ELV-35L	708.3630.350.20	250	45x2.0	56.0	34.5	51.0	50	41	941
ELV-42L	708.3630.420.20	250	52x2.0	63.0	40.0	56.0	60	50	1433
ELV-06S	708.3630.060.30	800	14x1.5	31.0	16.0	27.0	17	12	100
ELV-08S	708.3630.080.30	800	16x1.5	32.0	17.0	27.5	19	14	125
ELV-10S	708.3630.100.30	800	18x1.5	34.0	17.5	30.0	22	17	175
ELV-12S	708.3630.120.30	630	20x1.5	38.0	21.5	31.0	24	17	205
ELV-14S	708.3630.140.30	630	22x1.5	40.0	22.0	35.0	27	19	285
ELV-16S	708.3630.160.30	630	24x1.5	43.0	24.5	36.5	30	24	375
ELV-20S	708.3630.200.30	420	30x2.0	48.0	26.5	44.5	36	27	590
ELV-25S	708.3630.250.30	420	36x2.0	54.0	30.0	50.0	46	36	1130
ELV-30S	708.3630.300.30	420	42x2.0	62.0	35.5	55.0	50	41	1373
ELV-38S	708.3630.380.30	420	52x2.0	72.0	41.0	63.0	60	50	2070

Baumaße sind Ungefährmaße bei angezogener Überwurfmutter.

Sizes are approximate dimensions at tightened nut.

Las medidas son aproximadas con la tuerca de unión apretada.

Achtung: Für Endmontage des vormontierten Schaftes Überwurfmutter mit 1/4 Umdrehung über den Punkt des deutlich fühlbaren Kraftanstiegs anziehen.

Attention: For final assembly of the pre-assembled standpipe, tighten the union nut by 1/4 turn beyond the point of the clearly perceptible increase in force.

Atención: Para el ensamblaje final del vástago premontado, apriete la tuerca de unión 1/4 de vuelta más allá del punto del aumento claramente perceptible de la resistencia.

D1=Rohr außen-Ø
M1=metrisches Anschlußgewinde

D1=tube outside diameter
M1=metric connecting thread

D1=Ø exterior del tubo
M1=rosca métrica conexión

Einstellbare L-Einschraubverschraubungen mit Schaft

mit Einschraubstutzen, Abdichtung durch Dichtkante Form B nach DIN 3852-2

Adjustable male adaptor standpipe L fittings

with male adaptor connector, sealing edge form B acc. DIN 3852-2

Racores L para roscar ajustables con vástago

con racor para roscar, cierre hermético mediante borde de obturación forma B según DIN 3852-2

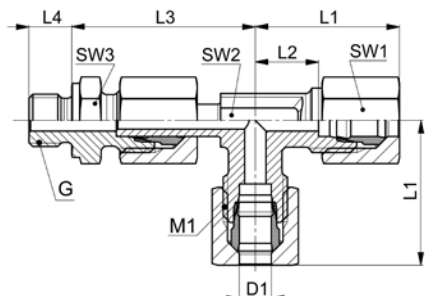

ELV-..LR/SR

Type-D1 G	Mat.-Nr.	PN	G	M1	L1	L2	L3	L4	SW1	SW2	SW3	g/Stk
G=Rohrgewinde (zylindrisch)		G=BSP thread (parallel)			G=rosca de conexión (cilíndrica)							
ELV-06LR 1.8	708.3652.100.20	500	1/8	12x1.5	27.0	12.0	34.5	10.0	14	12	14	77
ELV-08LR 1.4	708.3652.170.20	500	1/4	14x1.5	29.0	14.0	37.5	10.0	17	12	17	108
ELV-10LR 1.4	708.3652.270.20	500	1/4	16x1.5	30.5	15.0	40.0	11.0	19	14	19	129
ELV-12LR 3.8	708.3652.390.20	400	3/8	18x1.5	32.0	17.0	42.0	11.0	22	17	22	174
ELV-15LR 1.2	708.3652.534.20	400	1/2	22x1.5	36.5	21.0	46.5	12.0	27	19	27	296
ELV-18LR 1.2	708.3652.646.20	400	1/2	26x1.5	40.0	23.5	50.0	12.0	32	24	32	402
ELV-22LR 3.4	708.3652.768.20	250	3/4	30x2.0	44.5	27.5	55.0	14.0	36	27	36	582
ELV-28LR 1.1	708.3652.850.20	250	1	36x2.0	48.0	30.5	59.0	14.0	41	36	41	770
ELV-35LR 5.4	708.3652.944.20	250	1 1/4	45x2.0	57.0	34.5	68.5	16.0	50	41	50	1193
ELV-42LR 3.2	708.3652.992.20	250	1 1/2	52x2.0	63.5	40.0	75.5	16.0	60	50	60	1524
ELV-06SR 1.4	708.3652.111.30	800	1/4	14x1.5	31.0	16.0	40.0	12.0	17	12	17	127
ELV-08SR 1.4	708.3652.170.30	800	1/4	16x1.5	32.5	17.0	42.5	12.0	19	14	19	160
ELV-10SR 3.8	708.3652.280.30	800	3/8	18x1.5	35.0	17.5	45.0	12.0	22	17	22	223
ELV-12SR 3.8	708.3652.390.30	630	3/8	20x1.5	38.0	21.5	48.0	12.0	24	17	22	265
ELV-14SR 1.2	708.3652.504.30	630	1/2	22x1.5	41.0	22.0	54.0	14.0	27	19	27	377
ELV-16SR 1.2	708.3652.566.30	630	1/2	24x1.5	43.0	24.5	55.0	14.0	30	24	30	461
ELV-20SR 3.4	708.3652.704.30	420	3/4	30x2.0	50.0	26.5	67.0	14.0	36	27	36	788
ELV-25SR 1.1	708.3652.810.30	420	1	36x2.0	56.0	30.0	73.0	18.0	46	36	46	1477
ELV-30SR 5.4	708.3652.902.30	420	1 1/4	42x2.0	64.0	35.5	78.5	20.0	50	41	50	1796
ELV-38SR 3.2	708.3652.953.30	420	1 1/2	52x2.0	74.0	41.0	89.0	22.0	60	50	60	2189

Baumaße sind Ungefährmaße bei angezogener Überwurfmutter.

Sizes are approximate dimensions at tightened nut.

Las medidas son aproximadas con la tuerca de unión apretada.

Achtung: Für Endmontage des vormontierten Schaftes Überwurfmutter mit 1/4 Umdrehung über den Punkt des deutlich fühlbaren Kraftanstiegs anziehen.

Attention: For final assembly of the pre-assembled standpipe, tighten the union nut by 1/4 turn beyond the point of the clearly perceptible increase in force.

Atención: Para el ensamblaje final del vástago premontado, apriete la tuerca de unión 1/4 de vuelta más allá del punto del aumento claramente perceptible de la resistencia.

D1=Rohr außen-Ø
M1=metrisches Anschlußgewinde

D1=tube outside diameter
M1=metric connecting thread

D1=Ø exterior del tubo
M1=rosca métrica conexión

Einstellbare L-Einschraubverschraubungen

Für eine einstellbare L-Einschraubverschraubung kombinieren wir die einstellbare L-Verschraubung mit Schaft ELV-..L/S bzw. die einstellbare L-Verschraubung mit Dichtkegel ELKO-..L/S mit einem geraden Einschraubstutzen.

ELKO-..L/S + XGEV-..LR/SR = ELKO-..LR/SR
 ELV-..L/S + XGEV-..LR/SR = ELV-..LR/SR

Weitere Kombinationen sind möglich:

Adjustable male adaptor L fittings

For an adjustable male adaptor L fitting we combine the adjustable standpipe L fitting ELV-..L/S resp. the adjustable L fitting with taper ELKO-..L/S with a straight male adaptor union.

ELKO-..L/S + XGEV-..LR/SR = ELKO-..LR/SR
 ELV-..L/S + XGEV-..LR/SR = ELV-..LR/SR

Other combinations are possible:

Racores para roscar L ajustables

Para obtener un racor para roscar L ajustable combinamos el racor L ajustable con vástago ELV-..L/S o el racor L ajustable con junta cónica ELKO-..L/S con un racor para roscar recto.

ELKO-..L/S + XGEV-..LR/SR = ELKO-..LR/SR
 ELV-..L/S + XGEV-..LR/SR = ELV-..LR/SR

Son posibles otras combinaciones:

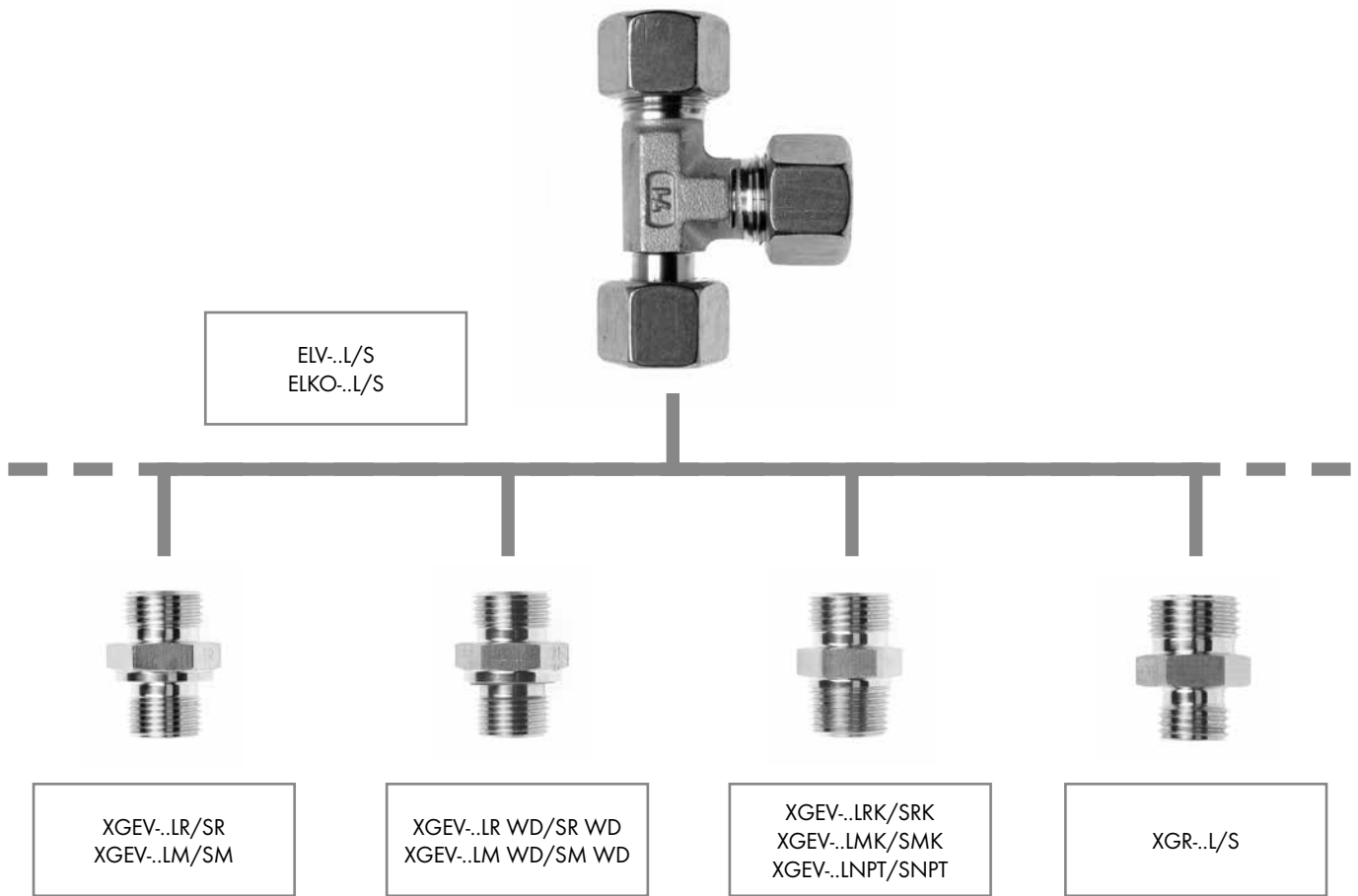

Kombination mit

- XGEV-..LR/SR, XGEV-..LM/SM für zylindrische Einschraubgewinde (zöllig bzw. metrisch) mit Abdichtung durch Dichtkante Form B nach DIN 3852-2
- XGEV-..LR WD/SR WD, XGEV-..LM WD/SM WD für zylindrische Einschraubgewinde (zöllig bzw. metrisch) mit Abdichtung durch Profildichtring Form E nach DIN 3852-11
- XGEV-..LRK/SRK, XGEV-..LMK/SMK, XGEV-..LNPT/SNPT für konische Einschraubgewinde (zöllig bzw. metrisch) mit Abdichtung im Kegelfgewinde Form C nach DIN 3852-2
- XGR-..L/S für den Übergang auf andere Anschlussgrößen

Das EXMAR Team steht Ihnen für Ihre Fragen gern zur Verfügung.

Combination with

- XGEV-..LR/SR, XGEV-..LM/SM for parallel male adaptor threads (English or metric) with sealing through seal edge form B acc. to DIN 3852-2
- XGEV-..LR WD/SR WD, XGEV-..LM WD/SM WD for parallel male adaptor threads (English or metric) with sealing through profile seal ring form E acc. to DIN 3852-11
- XGEV-..LRK/SRK, XGEV-..LMK/SMK, XGEV-..LNPT/SNPT for tapered male adaptor threads (English or metric) with taper thread sealing form C acc. to DIN 3852-2
- XGR-..L/S for transitioning to other connection sizes

The EXMAR Team would be glad to assist you with your questions.

Combinación con

- XGEV-..LR/SR, XGEV-..LM/SM para rosca de conexión cilíndrica (inglesa o métrica) con cierre hermético mediante junta de obturación según DIN 3852-2
- XGEV-..LR WD/SR WD, XGEV-..LM WD/SM WD para rosca de conexión cilíndrica (inglesa o métrica) con cierre hermético mediante junta anular de perfil, forma E según DIN 3852-11
- XGEV-..LRK/SRK, XGEV-..LMK/SMK, XGEV-..LNPT/SNPT para rosca de conexión cónica (inglesa o métrica) con cierre hermético mediante rosca cónica, forma C según DIN 3852-2
- XGR-..L/S para la transición a otros tamaños de conexión

El equipo de EXMAR está a su disposición para responder a sus consultas.

Winkel-Schwenkstutzen

Abdichtung mit metallischem Dichtkantenring

Banjo elbow connectors

sealing with metal seal-edge ring

Cuerpos orientables angulares

junta con anillo con borde de obturación metálico

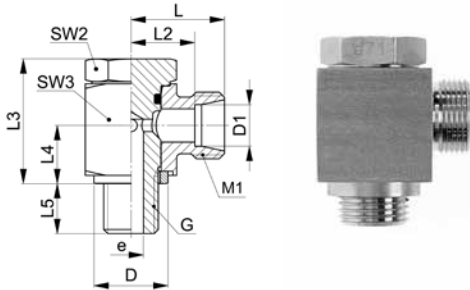

XESWV-..LR/SR

Type-D1 G	Mat.-Nr.	PN	G	M1	D	L	L2	L3	L4	L5	SW2	SW3	e	g/Stk	
G=Rohrgewinde (zylindrisch)		G=BSP thread (parallel)					G=rosca de conexión (cilíndrica)								
XESWV-06LLR 1.8	707.2850.100.10	100	1/8	10x1.0	14.0	15.5	10.0	21.0	10.0	8.0	14	15	4.5	36	
XESWV-08LLR 1.8	707.2850.160.10	100	1/8	12x1.0	14.0	16.5	11.0	21.0	10.0	8.0	14	15	4.5	44	
XESWV-06LR 1.8	707.2850.100.20	500	1/8	12x1.5	14.0	19.0	12.0	21.0	10.5	8.0	14	17	4.5	48	
XESWV-06LR 1.4	707.2850.110.20	500	1/4	12x1.5	18.0	19.0	12.0	30.0	14.0	12.0	19	19	6.0	48	
XESWV-08LR 1.4	707.2850.170.20	500	1/4	14x1.5	18.0	21.5	14.5	30.0	14.0	12.0	19	22	6.0	76	
XESWV-10LR 1.4	707.2850.270.20	500	1/4	16x1.5	18.0	22.5	15.5	30.0	14.0	12.0	19	22	6.0	81	
XESWV-12LR 1.4	707.2850.380.20	500	1/4	18x1.5	18.0	25.0	18.0	30.0	14.0	12.0	19	22	6.0	129	
XESWV-12LR 3.8	707.2850.390.20	500	3/8	18x1.5	21.0	25.0	18.0	34.5	16.5	12.0	22	27	7.5	130	
XESWV-15LR 1.2	707.2850.534.20	500	1/2	22x1.5	27.0	28.5	21.5	44.0	21.5	14.0	27	32	10.5	237	
XESWV-18LR 1.2	707.2850.646.20	400	1/2	26x1.5	27.0	28.5	21.5	44.0	21.5	14.0	27	32	10.5	251	
XESWV-22LR 3.4	707.2850.768.20	250	3/4	30x2.0	32.0	35.0	27.5	49.0	24.0	16.0	32	41	16.0	395	
XESWV-28LR 1.1	707.2850.850.20	250	1	36x2.0	39.0	39.5	32.0	60.0	30.5	18.0	41	46	20.0	776	
XESWV-35LR 5.4	707.2850.944.20	250	1 1/4	45x2.0	49.0	46.5	36.0	74.0	35.5	20.0	50	55	26.0	1345	
XESWV-42LR 3.2	707.2850.992.20	250	1 1/2	52x2.0	55.0	51.5	40.5	84.0	40.5	22.0	55	65	32.0	2088	
XESWV-06SR 1.4	707.2850.110.30	800	1/4	14x1.5	18.0	23.5	16.5	30.0	14.0	12.0	19	22	6.0	68	
XESWV-08SR 1.4	707.2850.170.30	800	1/4	16x1.5	18.0	23.5	16.5	30.0	14.0	12.0	19	22	6.0	81	
XESWV-10SR 3.8	707.2850.280.30	800	3/8	18x1.5	21.0	26.0	18.5	34.5	16.5	12.0	22	27	7.5	136	
XESWV-12SR 3.8	707.2850.390.30	630	3/8	20x1.5	21.0	26.0	18.5	34.5	16.5	12.0	22	27	7.5	142	
XESWV-14SR 1.2	707.2850.504.30	630	1/2	22x1.5	27.0	30.5	22.5	44.0	21.5	14.0	27	32	10.5	246	
XESWV-16SR 1.2	707.2850.566.30	630	1/2	24x1.5	27.0	30.5	22.0	44.0	21.5	14.0	27	32	10.5	245	
XESWV-20SR 3.4	707.2850.704.30	420	3/4	30x2.0	32.0	37.0	26.5	49.0	24.0	16.0	32	41	16.0	405	
XESWV-25SR 1.1	707.2850.810.30	420	1	36x2.0	39.0	43.5	31.5	60.0	30.5	18.0	41	46	20.0	805	
XESWV-30SR 5.4	707.2850.902.30	420	1 1/4	42x2.0	49.0	50.5	37.0	74.0	35.5	20.0	50	55	26.0	1389	
XESWV-38SR 3.2	707.2850.953.30	420	1 1/2	52x2.0	55.0	57.5	41.5	84.0	40.5	22.0	55	65	32.0	2264	

Dichtungsmaterial: FKM (andere Werkstoffe auf Anfrage). Vor Montage Dichtkante und Einschraubgewinde der Hohlverschraubung schmieren. Optional auch in rein metallischer Ausführung ohne O-Ring erhältlich.

Sealing material: FKM (other materials on request). Lubricate sealing edge and male thread of hollow bolt before assembly. Optionally available as pure metallic version without O-ring.

Material de junta tórica: FKM (otros materiales bajo demanda). Lubrique el borde de obturación y la rosca del tornillo hueco antes del montaje. Opcionalmente disponible como versión metálica sin junta tórica.

G	1/8	1/4	3/8	1/2	3/4	1	1 1/4	1 1/2
[Nm]	15	40	70	110	160	210	360	540

Anzugsdrehmoment für Hohlverschraubung in Nm

Tightening torque for hollow bolt in Nm

Pares de apriete para tornillo hueco en Nm

D1=Rohr außen-Ø
M1=metrisches Anschlußgewinde
e=kleinster Innen-Ø

D1=tube outside diameter
M1=metric connecting thread
e=minimum inside diameter

D1=Ø exterior del tubo
M1=rosca métrica conexión
e=Ø interior mínimo

Winkel-Schwenkverschraubungen

Abdichtung mit metallischem Dichtkantenring

Banjo elbow fittings

sealing with metal seal-edge ring

Racores orientables angulares

junta con anillo con borde de obturación metálico

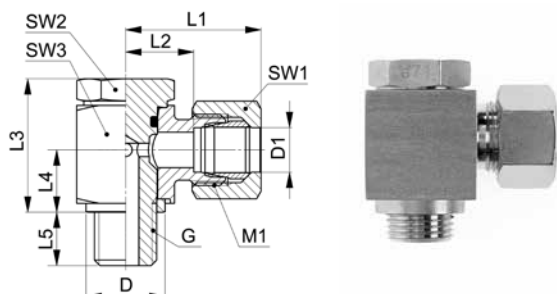

ESWV-..LR/SR

Type-D1 G	Mat.-Nr.	PN	G	M1	D	L1	L2	L3	L4	L5	SW1	SW2	SW3	g/Stk	
G=Rohrgewinde (zylindrisch)		G=BSP thread (parallel)					G=rosca de conexión (cilíndrica)								
ESWV-06LLR 1.8	708.2850.100.10	100	1/8	10x1.0	14.0	21.5	10.0	21.0	10.0	8.0	12	14	15	42	
ESWV-08LLR 1.8	708.2850.160.10	100	1/8	12x1.0	14.0	22.5	11.0	21.0	10.0	8.0	14	14	15	52	
ESWV-06LR 1.8	708.2850.100.20	500	1/8	12x1.5	14.0	27.0	12.0	21.0	10.5	8.0	14	14	17	59	
ESWV-08LR 1.4	708.2850.110.20	500	1/4	12x1.5	18.0	27.0	12.0	30.0	14.0	12.0	14	19	19	59	
ESWV-08LR 1.4	708.2850.170.20	500	1/4	14x1.5	18.0	29.5	14.5	30.0	14.0	12.0	17	19	22	93	
ESWV-10LR 1.4	708.2850.270.20	500	1/4	16x1.5	18.0	30.5	15.5	30.0	14.0	12.0	19	19	22	102	
ESWV-12LR 1.4	708.2850.380.20	500	1/4	18x1.5	18.0	33.0	18.0	30.0	14.0	12.0	22	19	22	158	
ESWV-12LR 3.8	708.2850.390.20	500	3/8	18x1.5	21.0	33.0	18.0	34.5	16.5	12.0	22	22	27	159	
ESWV-15LR 1.2	708.2850.534.20	500	1/2	22x1.5	27.0	36.5	21.5	44.0	21.5	14.0	27	27	32	284	
ESWV-18LR 1.2	708.2850.646.20	400	1/2	26x1.5	27.0	37.5	21.5	44.0	21.5	14.0	32	27	32	320	
ESWV-22LR 3.4	708.2850.768.20	250	3/4	30x2.0	32.0	44.0	27.5	49.0	24.0	16.0	36	32	41	485	
ESWV-28LR 1.1	708.2850.850.20	250	1	36x2.0	39.0	48.5	32.0	60.0	30.5	18.0	41	41	46	882	
ESWV-35LR 5.4	708.2850.944.20	250	1 1/4	45x2.0	49.0	57.5	36.0	74.0	35.5	20.0	50	50	55	1508	
ESWV-42LR 3.2	708.2850.992.20	250	1 1/2	52x2.0	55.0	63.5	40.5	84.0	40.5	22.0	60	55	65	2341	
ESWV-06SR 1.4	708.2850.110.30	800	1/4	14x1.5	18.0	31.5	16.5	30.0	14.0	12.0	17	19	22	87	
ESWV-08SR 1.4	708.2850.170.30	800	1/4	16x1.5	18.0	31.5	16.5	30.0	14.0	12.0	19	19	22	103	
ESWV-10SR 3.8	708.2850.280.30	800	3/8	18x1.5	21.0	35.0	18.5	34.5	16.5	12.0	22	22	27	170	
ESWV-12SR 3.8	708.2850.390.30	630	3/8	20x1.5	21.0	35.0	18.5	34.5	16.5	12.0	24	22	27	179	
ESWV-14SR 1.2	708.2850.504.30	630	1/2	22x1.5	27.0	40.5	22.5	44.0	21.5	14.0	27	27	32	303	
ESWV-16SR 1.2	708.2850.566.30	630	1/2	24x1.5	27.0	40.5	22.0	44.0	21.5	14.0	30	27	32	316	
ESWV-20SR 3.4	708.2850.704.30	420	3/4	30x2.0	32.0	48.0	26.5	49.0	24.0	16.0	36	32	41	518	
ESWV-25SR 1.1	708.2850.810.30	420	1	36x2.0	39.0	55.5	31.5	60.0	30.5	18.0	46	41	46	1030	
ESWV-30SR 5.4	708.2850.902.30	420	1 1/4	42x2.0	49.0	63.5	37.0	74.0	35.5	20.0	50	50	55	1637	
ESWV-38SR 3.2	708.2850.953.30	420	1 1/2	52x2.0	55.0	72.5	41.5	84.0	40.5	22.0	60	55	65	2627	

Baumaße sind Ungefährmaße bei angezogener Überwurfmutter.

Dichtungsmaterial: FKM (andere Werkstoffe auf Anfrage)

Vor Montage Dichtkante und Einschraubgewinde der Hohlverschraubung schmieren. Optional auch in rein metallischer Ausführung ohne O-Ring erhältlich.

Sizes are approximate dimensions at tightened nut.

Sealing material: FKM (other materials on request)

Lubricate sealing edge and male thread of hollow bolt before assembly. Optionally available as pure metallic version without O-ring.

Las medidas son aproximadas con la tuerca de unión apretada.

Material de junta tórica: FKM (otros materiales bajo demanda)

Lubrique el borde de obturación y la rosca del tornillo hueco antes del montaje. Opcionalmente disponible como versión metálica sin junta tórica.

G	1/8	1/4	3/8	1/2	3/4	1	1 1/4	1 1/2
[Nm]	15	40	70	110	160	210	360	540

Anzugsdrehmoment für Hohlverschraubung in Nm

Tightening torque for hollow bolt in Nm

Pares de apriete para tornillo hueco en Nm

D1=Rohr außen-Ø
M1=metrisches Anschlußgewinde

D1=tube outside diameter
M1=metric connecting thread

D1=Ø exterior del tubo
M1=rosca métrica conexión

Winkel-Schwenkstutzen

Abdichtung mit gekammertem FKM Weichdichtring

Banjo elbow connectors

sealing with restraining FKM seal ring

Cuerpos orientables angulares

junta con junta anular FKM blanda protegida

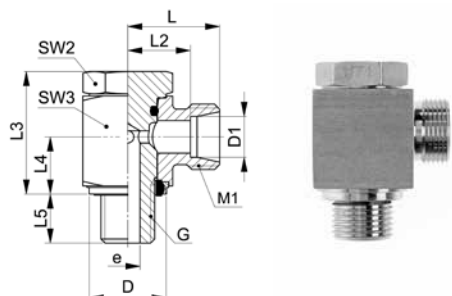

XESWV-..LR WD/SR WD

Type-D1 G	Mat.-Nr.	PN	G	M1	D	L	L2	L3	L4	L5	SW2	SW3	e	g/Stk	
G=Rohrgewinde (zylindrisch)		G=BSP thread (parallel)					G=rosca de conexión (cilíndrica)								
XESWV-06LLR 1.8 WD	707.2851.100.10	100	1/8	10x1.0	15.0	15.5	10.0	21.0	10.0	8.0	14	15	4.5	36	
XESWV-08LLR 1.8 WD	707.2851.160.10	100	1/8	12x1.0	15.0	16.5	11.0	21.0	10.0	8.0	14	15	4.5	44	
XESWV-06LR 1.8 WD	707.2851.100.20	500	1/8	12x1.5	15.0	19.0	12.0	21.0	10.5	8.0	14	17	4.5	48	
XESWV-06LR 1.4 WD	707.2851.110.20	500	1/4	12x1.5	19.0	19.0	12.0	30.0	14.0	12.0	19	19	6.0	48	
XESWV-08LR 1.4 WD	707.2851.170.20	500	1/4	14x1.5	19.0	21.5	14.5	30.0	14.0	12.0	19	22	6.0	76	
XESWV-10LR 1.4 WD	707.2851.270.20	500	1/4	16x1.5	19.0	22.5	15.5	30.0	14.0	12.0	19	22	6.0	81	
XESWV-12LR 1.4 WD	707.2851.380.20	500	1/4	18x1.5	19.0	25.0	18.0	30.0	14.0	12.0	19	22	6.0	129	
XESWV-12LR 3.8 WD	707.2851.390.20	500	3/8	18x1.5	22.0	25.0	18.0	34.5	16.5	12.0	22	27	7.5	130	
XESWV-15LR 1.2 WD	707.2851.534.20	500	1/2	22x1.5	27.0	28.5	21.5	44.0	21.5	14.0	27	32	10.5	237	
XESWV-18LR 1.2 WD	707.2851.646.20	400	1/2	26x1.5	27.0	28.5	21.5	44.0	21.5	14.0	27	32	10.5	251	
XESWV-22LR 3.4 WD	707.2851.768.20	250	3/4	30x2.0	33.0	35.0	27.5	49.0	24.0	16.0	32	41	16.0	395	
XESWV-28LR 1.1 WD	707.2851.850.20	250	1	36x2.0	40.0	39.5	32.0	60.0	30.5	18.0	41	46	20.0	776	
XESWV-35LR 5.4 WD	707.2851.944.20	250	1 1/4	45x2.0	50.0	46.5	36.0	74.0	35.5	20.0	50	55	26.0	1345	
XESWV-42LR 3.2 WD	707.2851.992.20	250	1 1/2	52x2.0	56.0	51.5	40.5	84.0	40.5	22.0	55	65	32.0	2088	
XESWV-06SR 1.4 WD	707.2851.110.30	800	1/4	14x1.5	19.0	23.5	16.5	30.0	14.0	12.0	19	22	6.0	68	
XESWV-08SR 1.4 WD	707.2851.170.30	800	1/4	16x1.5	19.0	23.5	16.5	30.0	14.0	12.0	19	22	6.0	81	
XESWV-10SR 3.8 WD	707.2851.280.30	800	3/8	18x1.5	22.0	26.0	18.5	34.5	16.5	12.0	22	27	7.5	136	
XESWV-12SR 3.8 WD	707.2851.390.30	630	3/8	20x1.5	22.0	26.0	18.5	34.5	16.5	12.0	22	27	7.5	142	
XESWV-14SR 1.2 WD	707.2851.504.30	630	1/2	22x1.5	27.0	30.5	22.5	44.0	21.5	14.0	27	32	10.5	246	
XESWV-16SR 1.2 WD	707.2851.566.30	630	1/2	24x1.5	27.0	30.5	22.0	44.0	21.5	14.0	27	32	10.5	245	
XESWV-20SR 3.4 WD	707.2851.704.30	420	3/4	30x2.0	33.0	37.0	26.5	49.0	24.0	16.0	32	41	16.0	405	
XESWV-25SR 1.1 WD	707.2851.810.30	420	1	36x2.0	40.0	43.5	31.5	60.0	30.5	18.0	41	46	20.0	805	
XESWV-30SR 5.4 WD	707.2851.902.30	420	1 1/4	42x2.0	50.0	50.5	37.0	74.0	35.5	20.0	50	55	26.0	1389	
XESWV-38SR 3.2 WD	707.2851.953.30	420	1 1/2	52x2.0	55.0	57.5	41.5	84.0	40.5	22.0	55	65	32.0	2264	

Dichtungsmaterial: FKM (andere Werkstoffe auf Anfrage)

Vor Montage Dichtkante und Einschraubgewinde der Hohlverschraubung schmieren.

Sealing material: FKM (other materials on request)

Lubricate sealing edge and male thread of hollow bolt before assembly.

Material de junta tórica: FKM (otros materiales bajo demanda)

Lubrique el borde de obturación y la rosca del tornillo hueco antes del montaje.

G	1/8	1/4	3/8	1/2	3/4	1	1 1/4	1 1/2
[Nm]	15	40	70	110	160	210	360	540

Anzugsdrehmoment für Hohlverschraubung in Nm

Tightening torque for hollow bolt in Nm

Pares de apriete para tornillo hueco en Nm

D1=Rohr außen-Ø
M1=metrisches Anschlußgewinde
e=kleinster Innen-Ø

D1=tube outside diameter
M1=metric connecting thread
e=minimum inside diameter

D1=Ø exterior del tubo
M1=rosca métrica conexión
e=Ø interior mínimo

Winkel-Schwenkverschraubungen

Abdichtung mit gekammertem FKM Weichdichtring

Banjo elbow fittings

sealing with restraining seal ring FKM

Racores orientables angulares

junta con anillo retentivo FKM blanda

10

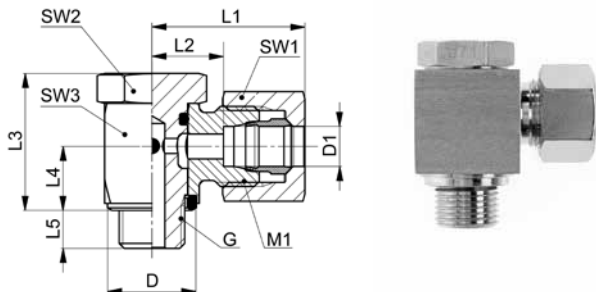

ESWV-..LR WD/SR WD

Type-D1 G	Mat.-Nr.	PN	G	M1	D	L1	L2	L3	L4	L5	SW1	SW2	SW3	g/Stk	
G=Rohrgewinde (zylindrisch)		G=BSP thread (parallel)					G=rosca de conexión (cilíndrica)								
ESWV-06LLR 1.8 WD	708.2851.100.10	100	1/8	10x1.0	15.0	21.5	10.0	21.0	10.0	8.0	12	14	15	42	
ESWV-08LLR 1.8 WD	708.2851.160.10	100	1/8	12x1.0	15.0	22.5	11.0	21.0	10.0	8.0	14	14	15	52	
ESWV-06LR 1.8 WD	708.2851.100.20	500	1/8	12x1.5	15.0	27.0	12.0	21.0	10.5	8.0	14	14	17	59	
ESWV-06LR 1.4 WD	708.2851.110.20	500	1/4	12x1.5	19.0	27.0	12.0	30.0	14.0	12.0	14	19	19	59	
ESWV-08LR 1.4 WD	708.2851.170.20	500	1/4	14x1.5	19.0	29.5	14.5	30.0	14.0	12.0	17	19	22	93	
ESWV-10LR 1.4 WD	708.2851.270.20	500	1/4	16x1.5	19.0	30.5	15.5	30.0	14.0	12.0	19	19	22	102	
ESWV-12LR 1.4 WD	708.2851.380.20	500	1/4	18x1.5	19.0	33.0	18.0	30.0	14.0	12.0	22	19	22	158	
ESWV-12LR 3.8 WD	708.2851.390.20	500	3/8	18x1.5	22.0	33.0	18.0	34.5	16.5	12.0	22	22	27	159	
ESWV-15LR 1.2 WD	708.2851.534.20	500	1/2	22x1.5	27.0	36.5	21.5	44.0	21.5	14.0	27	27	32	284	
ESWV-18LR 1.2 WD	708.2851.646.20	400	1/2	26x1.5	27.0	37.5	21.5	44.0	21.5	14.0	32	27	32	320	
ESWV-22LR 3.4 WD	708.2851.768.20	250	3/4	30x2.0	33.0	44.0	27.5	49.0	24.0	16.0	36	32	41	485	
ESWV-28LR 1.1 WD	708.2851.850.20	250	1	36x2.0	40.0	48.5	32.0	60.0	30.5	18.0	41	41	46	882	
ESWV-35LR 5.4 WD	708.2851.944.20	250	1 1/4	45x2.0	50.0	57.5	36.0	74.0	35.5	20.0	50	50	55	1508	
ESWV-42LR 3.2 WD	708.2851.992.20	250	1 1/2	52x2.0	56.0	63.5	40.5	84.0	40.5	22.0	60	55	65	2341	
ESWV-06SR 1.4 WD	708.2851.110.30	800	1/4	14x1.5	19.0	31.5	16.5	30.0	14.0	12.0	17	19	22	87	
ESWV-08SR 1.4 WD	708.2851.170.30	800	1/4	16x1.5	19.0	31.5	16.5	30.0	14.0	12.0	19	19	22	103	
ESWV-10SR 3.8 WD	708.2851.280.30	800	3/8	18x1.5	22.0	35.0	18.5	34.5	16.5	12.0	22	22	27	170	
ESWV-12SR 3.8 WD	708.2851.390.30	630	3/8	20x1.5	22.0	35.0	18.5	34.5	16.5	12.0	24	22	27	179	
ESWV-14SR 1.2 WD	708.2851.504.30	630	1/2	22x1.5	27.0	40.5	22.5	44.0	21.5	14.0	27	27	32	303	
ESWV-16SR 1.2 WD	708.2851.566.30	630	1/2	24x1.5	27.0	40.5	22.0	44.0	21.5	14.0	30	27	32	316	
ESWV-20SR 3.4 WD	708.2851.704.30	420	3/4	30x2.0	33.0	48.0	26.5	49.0	24.0	16.0	36	32	41	518	
ESWV-25SR 1.1 WD	708.2851.810.30	420	1	36x2.0	40.0	55.5	31.5	60.0	30.5	18.0	46	41	46	1030	
ESWV-30SR 5.4 WD	708.2851.902.30	420	1 1/4	42x2.0	50.0	63.5	37.0	74.0	35.5	20.0	50	50	55	1637	
ESWV-38SR 3.2 WD	708.2851.953.30	420	1 1/2	52x2.0	56.0	72.5	41.5	84.0	40.5	22.0	60	55	65	2627	

Baumaße sind Ungefährmaße bei angezogener Überwurfmutter.
Dichtungsmaterial: FKM (andere Werkstoffe auf Anfrage). Vor Montage Dichtkante und Einschraubgewinde der Hohlverschraubung schmieren.

Sizes are approximate dimensions at tightened nut.
Sealing material: FKM (other materials on request). Lubricate sealing edge and male thread of hollow bolt before assembly.

Las medidas son aproximadas con la tuerca de unión apretada.
Material de junta tórica: FKM (otros materiales bajo demanda). Lubrique el borde de obturación y la rosca del tornillo hueco antes del montaje.

G	1/8	1/4	3/8	1/2	3/4	1	1 1/4	1 1/2
[Nm]	15	40	70	110	160	210	360	540

Anzugsdrehmoment für Hohlverschraubung in Nm

Tightening torque for hollow bolt in Nm

Pares de apriete para tornillo hueco en Nm

Winkel-Schwenkstutzen

Abdichtung mit metallischem Dichtkantenring

Banjo elbow connectors

sealing with metal seal-edge ring

Cuerpos orientables angulares

junta con anillo con borde de obturación metálico

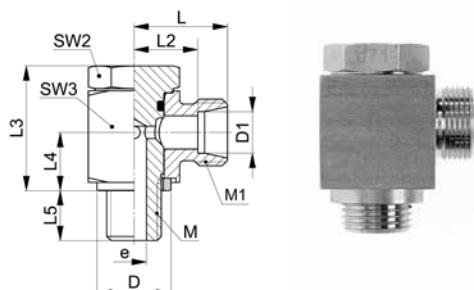

XESWV-..LM/SM

Type-D1 M	Mat.-Nr.	PN	M	M1	D	L	L2	L3	L4	L5	SW2	SW3	e	g/Stk
M=metrisches Gewinde (zylindrisch)	M=metric thread (parallel)	M=rosca métrica (cilíndrica)												
XESWV-06LLM 10x1,0	707.2853.180.10	100	10x1.0	10x1.0	14.0	15.5	10.0	21.0	10.0	8.0	14	15	4.5	36
XESWV-08LLM 10x1,0	707.2853.230.10	100	10x1.0	12x1.0	14.0	16.5	11.0	21.0	10.0	8.0	14	15	4.5	37
XESWV-06LM 10x1,0	707.2853.180.20	500	10x1.0	12x1.5	14.0	19.0	12.0	21.0	10.5	8.0	14	17	4.5	48
XESWV-08LM 12x1,5	707.2853.240.20	500	12x1.5	14x1.5	18.0	21.5	14.5	30.0	14.0	12.0	19	22	6.0	73
XESWV-10LM 14x1,5	707.2853.280.20	500	14x1.5	16x1.5	18.0	22.5	15.5	30.0	14.0	12.0	19	22	6.0	82
XESWV-12LM 16x1,5	707.2853.330.20	500	16x1.5	18x1.5	21.0	25.0	18.0	34.5	16.5	12.0	22	27	7.5	129
XESWV-15LM 18x1,5	707.2853.390.20	500	18x1.5	22x1.5	23.0	28.5	21.5	38.5	18.5	12.0	24	27	9.0	162
XESWV-18LM 22x1,5	707.2853.460.20	500	22x1.5	26x1.5	27.0	28.5	21.0	44.0	21.5	14.0	27	32	10.5	251
XESWV-22LM 26x1,5	707.2853.535.20	250	26x1.5	30x2.0	32.0	35.0	27.5	49.0	24.0	16.0	32	41	16.0	395
XESWV-28LM 33x2,0	707.2853.570.20	250	33x2.0	36x2.0	39.0	39.5	32.0	60.0	30.5	18.0	41	46	20.0	776
XESWV-35LM 42x2,0	707.2853.600.20	250	42x2.0	45x2.0	49.0	46.5	36.0	74.0	35.5	20.0	50	55	26.0	1345
XESWV-42LM 48x2,0	707.2853.992.20	250	48x2.0	52x2.0	55.0	51.5	40.5	84.0	40.5	22.0	55	65	32.0	2088
XESWV-06SM 12x1,5	707.2853.195.30	800	12x1.5	14x1.5	18.0	23.5	16.5	30.0	14.0	12.0	19	22	6.0	66
XESWV-08SM 14x1,5	707.2853.245.30	800	14x1.5	16x1.5	18.0	23.5	16.5	30.0	14.0	12.0	19	22	6.0	81
XESWV-10SM 16x1,5	707.2853.285.30	800	16x1.5	18x1.5	21.0	26.0	18.5	34.5	16.5	12.0	22	27	7.5	136
XESWV-12SM 18x1,5	707.2853.333.30	630	18x1.5	20x1.5	23.0	27.5	20.0	38.5	18.5	12.0	24	27	9.0	183
XESWV-14SM 20x1,5	707.2853.382.30	630	20x1.5	22x1.5	26.0	30.5	22.5	44.0	21.5	14.0	27	32	10.5	223
XESWV-16SM 22x1,5	707.2853.410.30	630	22x1.5	24x1.5	27.0	30.5	22.0	44.0	21.5	14.0	27	32	10.5	249
XESWV-20SM 27x2,0	707.2853.506.30	420	27x2.0	30x2.0	32.0	37.0	26.5	49.0	24.0	16.0	32	41	16.0	405
XESWV-25SM 33x2,0	707.2853.550.30	420	30x2.0	36x2.0	39.0	43.5	31.5	60.0	30.5	18.0	41	46	20.0	805
XESWV-30SM 42x2,0	707.2853.600.30	420	42x2.0	42x2.0	49.0	50.5	37.0	74.0	35.5	20.0	50	55	26.0	1392
XESWV-38SM 48x2,0	707.2853.954.30	420	48x2.0	52x2.0	55.0	57.5	41.5	84.0	40.5	22.0	55	65	32.0	2167

Dichtungsmaterial: FKM (andere Werkstoffe auf Anfrage)

Vor Montage Dichtkante und Einschraubgewinde der Hohlverschraubung schmieren.

Optional auch in rein metallischer Ausführung ohne O-Ring erhältlich.

Sealing material: FKM (other materials on request)

Lubricate sealing edge and male thread of hollow bolt before assembly.

Optionally available as pure metallic version without O-ring.

Material de junta tórica: FKM (otros materiales bajo demanda)

Lubrique el borde de obturación y la rosca del tornillo hueco antes del montaje.

Opcionalmente disponible como versión metálica sin junta tórica.

M	10x1.0	12/14x1.5	16x1.5	18x1.5	20x1.5	22x1.5	26x1.5	27x2.0	33x2.0	42x2.0	48x2.0
[Nm]	15	25	45	60	110	80	150	160	210	360	540

Anzugsdrehmoment für Hohlverschraubung in Nm

Tightening torque for hollow bolt in Nm

Pares de apriete para tornillo hueco en Nm

D1=Rohr außen-Ø
M1=metrisches Anschlußgewinde
e=kleinster Innen-Ø

D1=tube outside diameter
M1=metric connecting thread
e=minimum inside diameter

D1=Ø exterior del tubo
M1=rosca métrica conexión
e=Ø interior mínimo

Winkel-Schwenkverschraubungen

Abdichtung mit metallischem Dichtkantenring

Banjo elbow fittings

sealing with metal seal-edge ring

Racores orientables angulares

junta con anillo con borde de obturación metálico

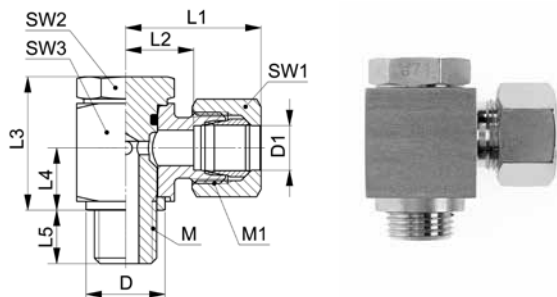

ESWV-..LM/SM

Type-D1 M	Mat.-Nr.	PN	M	M1	D	L1	L2	L3	L4	L5	SW1	SW2	SW3	g/Stk
M=metrisches Gewinde (zylindrisch)	M=metric thread (parallel)	M=rosca métrica (cilíndrica)												
ESWV-06LLM 10x1,0	708.2853.180.10	100	10x1.0	10x1.0	14.0	21.5	10.0	21.0	10.0	8.0	12	14	15	42
ESWV-08LLM 10x1,0	708.2853.230.10	100	10x1.0	12x1.0	14.0	22.5	11.0	21.0	10.0	8.0	14	14	15	45
ESWV-06LM 10x1,0	708.2853.180.20	500	10x1.0	12x1.5	14.0	27.0	12.0	21.0	10.5	8.0	14	14	17	59
ESWV-08LM 12x1,5	708.2853.240.20	500	12x1.5	14x1.5	18.0	29.5	14.5	30.0	14.0	12.0	17	19	22	90
ESWV-10LM 14x1,5	708.2853.280.20	500	14x1.5	16x1.5	18.0	30.5	15.5	30.0	14.0	12.0	19	19	22	103
ESWV-12LM 16x1,5	708.2853.330.20	500	16x1.5	18x1.5	21.0	33.0	18.0	34.5	16.5	12.0	22	22	27	158
ESWV-15LM 18x1,5	708.2853.390.20	500	18x1.5	26x1.5	23.0	36.5	21.5	38.5	18.5	12.0	27	24	27	209
ESWV-18LM 22x1,5	708.2853.460.20	500	22x1.5	26x1.5	27.0	37.5	21.0	44.0	21.5	14.0	32	27	32	320
ESWV-22LM 26x1,5	708.2853.535.20	250	26x1.5	30x2.0	32.0	44.0	27.5	49.0	24.0	16.0	36	32	41	485
ESWV-28LM 33x2,0	708.2853.570.20	250	33x2.0	36x2.0	39.0	48.5	32.0	60.0	30.5	18.0	41	41	46	882
ESWV-35LM 42x2,0	708.2853.600.20	250	42x2.0	45x2.0	49.0	57.5	36.0	74.0	35.5	20.0	50	50	55	1508
ESWV-42LM 48x2,0	708.2853.992.20	250	48x2.0	52x2.0	55.0	63.5	40.5	84.0	40.5	22.0	60	55	65	2341
ESWV-06SM 12x1,5	708.2853.195.30	800	12x1.5	14x1.5	18.0	31.5	16.5	30.0	14.0	12.0	17	19	22	85
ESWV-08SM 14x1,5	708.2853.245.30	800	14x1.5	16x1.5	18.0	31.5	16.5	30.0	14.0	12.0	19	19	22	103
ESWV-10SM 16x1,5	708.2853.285.30	800	16x1.5	18x1.5	21.0	35.0	18.5	34.5	16.5	12.0	22	22	27	170
ESWV-12SM 18x1,5	708.2853.333.30	630	18x1.5	20x1.5	23.0	36.5	20.0	38.5	18.5	12.0	24	24	27	220
ESWV-14SM 20x1,5	708.2853.382.30	630	20x1.5	22x1.5	27.0	40.5	22.5	44.0	21.5	14.0	27	27	32	280
ESWV-16SM 22x1,5	708.2853.410.30	630	22x1.5	24x1.5	27.0	40.5	22.0	44.0	21.5	14.0	30	27	32	320
ESWV-20SM 27x2,0	708.2853.506.30	420	27x2.0	30x2.0	32.0	48.0	26.5	49.0	24.0	16.0	36	32	41	518
ESWV-25SM 33x2,0	708.2853.550.30	420	33x2.0	36x2.0	39.0	55.5	31.5	60.0	30.5	18.0	46	41	46	1030
ESWV-30SM 42x2,0	708.2853.600.30	420	42x2.0	42x2.0	49.0	63.5	37.0	74.0	35.5	20.0	50	50	55	1640
ESWV-38SM 48x2,0	708.2853.954.30	420	48x2.0	52x2.0	55.0	72.5	41.5	84.0	40.5	22.0	60	55	65	2530

Baumaße sind Ungefährmaße bei angezogener Überwurfmutter.

Sizes are approximate dimensions at tightened nut.

Las medidas son aproximadas con la tuerca de unión apretada.

Dichtungsmaterial: FKM (andere Werkstoffe auf Anfrage)

Sealing material: FKM (other materials on request)

Material de junta tórica: FKM (otros materiales bajo demanda)

Vor Montage Dichtkante und Einschraubgewinde der Hohlverschraubung schmieren. Optional auch in rein metallischer Ausführung ohne O-Ring erhältlich.

Lubricate sealing edge and male thread of hollow bolt before assembly. Optionally available as pure metallic version without O-ring.

Lubrique el borde de obturación y la rosca del tornillo hueco antes del montaje. Opcionalmente disponible como versión metálica sin junta tórica.

M	10x1.0	12/14x1.5	16x1.5	18x1.5	20x1.5	22x1.5	26x1.5	27x2.0	33x2.0	42x2.0	48x2.0
[Nm]	15	25	45	60	110	80	150	160	210	360	540

Anzugsdrehmoment für Hohlverschraubung in Nm

Tightening torque for hollow bolt in Nm

Pares de apriete para tornillo hueco en Nm

D1=Rohr außen-Ø
M1=metrisches Anschlußgewinde

D1=tube outside diameter
M1=metric connecting thread

D1=Ø exterior del tubo
M1=rosca métrica conexión

Winkel-Schwenkstutzen

Abdichtung mit gekammertem FKM Weichdichtring

Banjo elbow connectors

sealing with restraining FKM seal ring

Cuerpos orientables angulares

junta con junta anular FKM blanda protegida

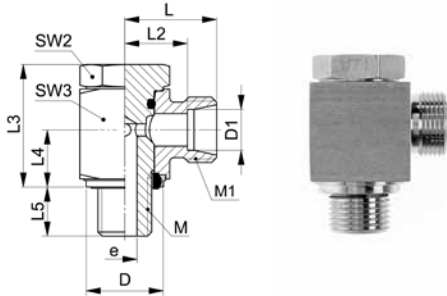

XESWV-..LM WD/SM WD

Type-D1 M	Mat.-Nr.	PN	M	M1	D	L	L2	L3	L4	L5	SW2	SW3	e	g/Stk
M=metrisches Gewinde (zylindrisch)	M=metric thread (parallel)	M=rosca métrica (cilindrica)												
XESWV-06LLM 10x1,0 WD	707.2852.180.10	100	10x1.0	10x1.0	15.0	15.5	10.0	21.0	10.0	8.0	14	15	4.5	36
XESWV-08LLM 10x1,0 WD	707.2852.230.10	100	10x1.0	12x1.0	15.0	16.5	11.0	21.0	10.0	8.0	14	15	4.5	37
XESWV-06LM 10x1,0 WD	707.2852.180.20	500	10x1.0	12x1.5	15.0	19.0	12.0	21.0	10.5	8.0	14	17	4.5	48
XESWV-08LM 12x1,5 WD	707.2852.240.20	500	12x1.5	14x1.5	19.0	21.5	14.5	30.0	14.0	12.0	19	22	6.0	73
XESWV-10LM 14x1,5 WD	707.2852.280.20	500	14x1.0	16x1.5	19.0	22.5	15.5	30.0	14.0	12.0	19	22	6.0	82
XESWV-12LM 16x1,5 WD	707.2852.330.20	500	16x1.5	18x1.5	22.0	25.0	18.0	34.5	16.5	12.0	22	27	7.5	129
XESWV-15LM 18x1,5 WD	707.2852.390.20	500	18x1.5	22x1.5	24.0	28.5	21.5	38.5	18.5	12.0	24	27	9.0	162
XESWV-18LM 22x1,5 WD	707.2852.460.20	500	22x1.5	26x1.5	27.0	28.5	21.0	44.0	21.5	14.0	27	32	10.5	251
XESWV-22LM 26x1,5 WD	707.2852.535.20	250	26x1.5	30x2.0	33.0	35.0	27.5	49.0	24.0	16.0	32	41	16.0	395
XESWV-28LM 33x2,0 WD	707.2852.570.20	250	33x2.0	36x2.0	40.0	39.5	32.0	60.0	30.5	18.0	41	46	20.0	776
XESWV-35LM 42x2,0 WD	707.2852.600.20	250	42x2.0	45x2.0	50.0	46.5	36.0	74.0	35.5	20.0	50	55	26.0	1345
XESWV-42LM 48x2,0 WD	707.2852.992.20	250	48x2.0	52x2.0	56.0	51.5	40.5	84.0	40.5	22.0	55	65	32.0	2088
XESWV-06SM 12x1,5 WD	707.2852.195.30	800	12x1.5	14x1.5	19.0	23.5	16.5	30.0	14.0	12.0	19	22	6.0	66
XESWV-08SM 14x1,5 WD	707.2852.245.30	800	14x1.5	16x1.5	19.0	23.5	16.5	30.0	14.0	12.0	19	22	6.0	81
XESWV-10SM 16x1,5 WD	707.2852.285.30	800	16x1.5	18x1.5	22.0	26.0	18.5	34.5	16.5	12.0	22	27	7.5	136
XESWV-12SM 18x1,5 WD	707.2852.333.30	630	18x1.5	20x1.5	24.0	27.5	20.0	38.5	18.5	12.0	24	27	9.0	183
XESWV-14SM 20x1,5 WD	707.2852.382.30	630	20x1.5	22x1.5	27.0	30.5	22.5	44.0	21.5	14.0	27	32	10.5	223
XESWV-16SM 22x1,5 WD	707.2852.410.30	630	22x1.5	24x1.5	27.0	30.5	22.0	44.0	21.5	14.0	27	32	10.5	249
XESWV-20SM 27x2,0 WD	707.2852.506.30	420	27x2.0	30x2.0	33.0	37.0	26.5	49.0	24.0	16.0	32	41	16.0	405
XESWV-25SM 33x2,0 WD	707.2852.550.30	420	33x2.0	36x2.0	40.0	43.5	31.5	60.0	30.5	18.0	41	46	20.0	805
XESWV-30SM 42x2,0 WD	707.2852.600.30	420	42x2.0	42x2.0	50.0	50.5	37.0	74.0	35.5	20.0	50	55	26.0	1392
XESWV-38SM 48x2,0 WD	707.2852.954.30	420	48x2.0	52x2.0	56.0	57.5	41.5	84.0	40.5	22.0	55	65	32.0	2167

Dichtungsmaterial: FKM (andere Werkstoffe auf Anfrage)

Vor Montage Dichtkante und Einschraubgewinde der Hohlverschraubung schmieren.

Sealing material: FKM (other materials on request)

Lubricate sealing edge and male thread of hollow bolt before assembly.

Material de junta tórica: FKM (otros materiales bajo demanda)

Lubrique el borde de obturación y la rosca del tornillo hueco antes del montaje.

M	10x1.0	12/14x1.5	16x1.5	18x1.5	20x1.5	22x1.5	26x1.5	27x2.0	33x2.0	42x2.0	48x2.0
[Nm]	15	25	45	60	110	80	150	160	210	360	540

Anzugsdrehmoment für Hohlverschraubung in Nm

Tightening torque for hollow bolt in Nm

Pares de apriete para tornillo hueco en Nm

D1=Rohr außen-Ø
M1=metrisches Anschlußgewinde
e=kleinster Innen-Ø

D1=tube outside diameter
M1=metric connecting thread
e=minimum inside diameter

D1=Ø exterior del tubo
M1=rosca métrica conexión
e=Ø interior mínimo

Winkel-Schwenkverschraubungen

Abdichtung mit gekammertem FKM Weichdichtring

Banjo elbow fittings

sealing with restraining seal ring FKM

Racores orientables angulares

junta con anillo retentivo FKM blanda

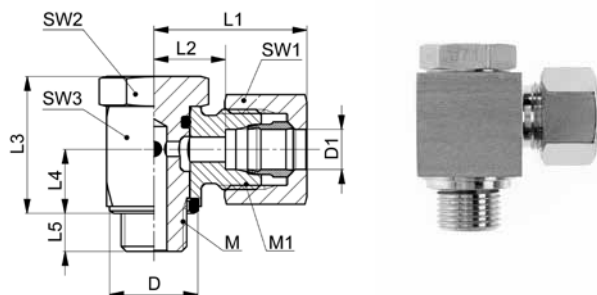

ESWV-..LM WD / SM WD

Type-D1 M	Mat.-Nr.	PN	M	M1	D	L1	L2	L3	L4	L5	SW1	SW2	SW3	g/Stk
M=metrisches Gewinde (zylindrisch)	M=metric thread (parallel)	M=rosca métrica (cilíndrica)												
ESWV-06LLM 10x1,0 WD	708.2852.180.10	100	10x1.0	10x1.0	15.0	21.5	10.0	21.0	10.0	8.0	12	14	15	42
ESWV-08LLM 10x1,0 WD	708.2852.230.10	100	10x1.0	12x1.0	15.0	22.5	11.0	21.0	10.0	8.0	14	14	15	45
ESWV-06LM 10x1,0 WD	708.2852.180.20	500	10x1.0	12x1.5	15.0	27.0	12.0	21.0	10.5	8.0	14	14	17	59
ESWV-08LM 12x1,5 WD	708.2852.240.20	500	12x1.5	14x1.5	19.0	29.5	14.5	30.0	14.0	12.0	17	19	22	90
ESWV-10LM 14x1,5 WD	708.2852.280.20	500	14x1.5	16x1.5	19.0	30.5	15.5	30.0	14.0	12.0	19	19	22	103
ESWV-12LM 16x1,5 WD	708.2852.330.20	500	16x1.5	18x1.5	22.0	33.0	18.0	34.5	16.5	12.0	22	22	27	158
ESWV-15LM 18x1,5 WD	708.2852.390.20	500	18x1.5	22x1.5	24.0	36.5	21.5	38.5	18.5	12.0	27	24	27	209
ESWV-18LM 22x1,5 WD	708.2852.460.20	500	22x1.5	26x1.5	27.0	37.5	21.0	44.0	21.5	14.0	32	27	32	320
ESWV-22LM 26x1,5 WD	708.2852.535.20	250	26x1.5	30x2.0	33.0	44.0	27.5	49.0	24.0	16.0	36	32	41	485
ESWV-28LM 33x2,0 WD	708.2852.570.20	250	33x2.0	36x2.0	40.0	48.5	32.0	60.0	30.5	18.0	41	41	46	882
ESWV-35LM 42x2,0 WD	708.2852.600.20	250	42x2.0	45x2.0	50.0	57.5	36.0	74.0	35.5	20.0	50	50	55	1508
ESWV-42LM 48x2,0 WD	708.2852.992.20	250	48x2.0	52x2.0	56.0	63.5	40.5	84.0	40.5	22.0	60	55	65	2341
ESWV-06SM 12x1,5 WD	708.2852.195.30	800	12x1.5	14x1.5	19.0	31.5	16.5	30.0	14.0	12.0	17	19	22	85
ESWV-08SM 14x1,5 WD	708.2852.245.30	800	14x1.5	16x1.5	19.0	31.5	16.5	30.0	14.0	12.0	19	19	22	103
ESWV-10SM 16x1,5 WD	708.2852.285.30	800	16x1.5	18x1.5	22.0	35.0	18.5	34.5	16.5	12.0	22	22	27	170
ESWV-12SM 18x1,5 WD	708.2852.333.30	800	18x1.5	20x1.5	24.0	36.5	20.0	38.5	18.5	12.0	24	24	27	220
ESWV-14SM 20x1,5 WD	708.2852.382.30	800	20x1.5	22x1.5	27.0	40.5	22.5	44.0	21.5	14.0	27	27	32	280
ESWV-16SM 22x1,5 WD	708.2852.410.30	630	22x1.5	24x1.5	27.0	40.5	22.0	44.0	21.5	14.0	30	27	32	320
ESWV-20SM 27x2,0 WD	708.2852.506.30	420	27x2.0	30x2.0	33.0	48.0	26.5	49.0	24.0	16.0	36	32	41	518
ESWV-25SM 33x2,0 WD	708.2852.550.30	420	33x2.0	36x2.0	40.0	55.5	31.5	60.0	30.5	18.0	46	41	46	1030
ESWV-30SM 42x2,0 WD	708.2852.600.30	420	42x2.0	42x2.0	50.0	63.5	37.0	74.0	35.5	20.0	50	50	55	1640
ESWV-38SM 48x2,0 WD	708.2852.954.30	420	48x2.0	52x2.0	56.0	72.5	41.5	84.0	40.5	22.0	60	55	65	2530

Baumäße sind Ungefährmaße bei angezogener Überwurfmutter.
Dichtungsmaterial: FKM (andere Werkstoffe auf Anfrage). Vor Montage Dichtkante und Einschraubgewinde der Hohlverschraubung schmieren.

Sizes are approximate dimensions at tightened nut.
Sealing material: FKM (other materials on request). Lubricate sealing edge and male thread of hollow bolt before assembly.

Las medidas son aproximadas con la tuerca de unión apretada.
Material de junta tórica: FKM (otros materiales bajo demanda). Lubrique el borde de obturación y la rosca del tornillo hueco antes del montaje.

M	10x1.0	12/14x1.5	16x1.5	18x1.5	20x1.5	22x1.5	26x1.5	27x2.0	33x2.0	42x2.0	48x2.0
[Nm]	15	25	45	60	110	80	150	160	210	360	540

Anzugsdrehmoment für Hohlverschraubung in Nm

Tightening torque for hollow bolt in Nm

Pares de apriete para tornillo hueco en Nm

D1=Rohr außen-Ø
M1=metrisches Anschlußgewinde

D1=tube outside diameter
M1=metric connecting thread

D1=Ø exterior del tubo
M1=rosca métrica conexión

Gerade Aufschraubstutzen
Straight female adaptor connectors
Cuerpos atornillables rectos

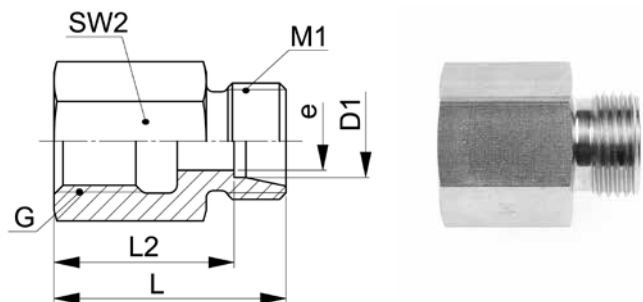

XGAV-..LR

Type-D1 G	Mat.-Nr.	PN	G	M1	L	L2	SW2	e	g/Stk
G=Rohrgewinde (zylindrisch)		G=BSP thread (parallel)			G=rosca de conexión (cilíndrica)				
XGAV-06LR 1.8	706.1201.100.20	500	1/8	12x1.5	26.0	19.0	14	4.0	18
XGAV-06LR 1.4	706.1201.110.20	500	1/4	12x1.5	31.0	24.0	19	4.0	38
XGAV-08LR 1.4	706.1201.170.20	500	1/4	14x1.5	31.0	24.0	19	6.0	36
XGAV-08LR 3.8	706.1201.180.20	500	3/8	14x1.5	32.0	25.0	24	6.0	62
XGAV-08LR 1.2	706.1201.185.20	500	1/2	14x1.5	36.0	29.0	27	6.0	54
XGAV-10LR 1.4	706.1201.270.20	500	1/4	16x1.5	32.0	25.0	19	8.0	40
XGAV-10LR 3.8	706.1201.280.20	500	3/8	16x1.5	33.0	26.0	24	8.0	48
XGAV-10LR 1.2	706.1201.285.20	500	1/2	16x1.5	37.0	30.0	27	8.0	80
XGAV-12LR 1.4	706.1201.380.20	400	1/4	18x1.5	32.0	25.0	19	10.0	40
XGAV-12LR 3.8	706.1201.390.20	400	3/8	18x1.5	33.0	26.0	24	10.0	62
XGAV-12LR 1.2	706.1201.400.20	400	1/2	18x1.5	37.0	30.0	27	10.0	78
XGAV-15LR 3.8	706.1201.532.20	400	3/8	22x1.5	34.0	27.0	24	12.0	68
XGAV-15LR 1.2	706.1201.534.20	400	1/2	22x1.5	38.0	31.0	27	12.0	86
XGAV-18LR 3.8	706.1201.644.20	400	3/8	26x1.5	34.0	26.5	27	14.0	100
XGAV-18LR 1.2	706.1201.646.20	400	1/2	26x1.5	38.0	30.5	27	15.0	88
XGAV-22LR 3.4	706.1201.768.20	250	3/4	30x2.0	43.0	35.5	36	19.0	178
XGAV-28LR 1.1	706.1201.850.20	250	1	36x2.0	45.5	38.0	41	24.0	214
XGAV-35LR 5.4	706.1201.944.20	250	1 1/4	45x2.0	51.5	41.0	55	30.0	472
XGAV-42LR 3.2	706.1201.992.20	250	1 1/2	52x2.0	53.5	42.5	60	36.0	540

D1=Rohr außen-Ø
M1=metrisches Anschlußgewinde
e=kleinster Innen-Ø

D1=tube outside diameter
M1=metric connecting thread
e=minimum inside diameter

D1=Ø exterior del tubo
M1=rosca métrica conexión
e=Ø interior mínimo

Gerade Aufschraubverschraubungen
Straight female adaptor fittings
Racores atornillables rectos

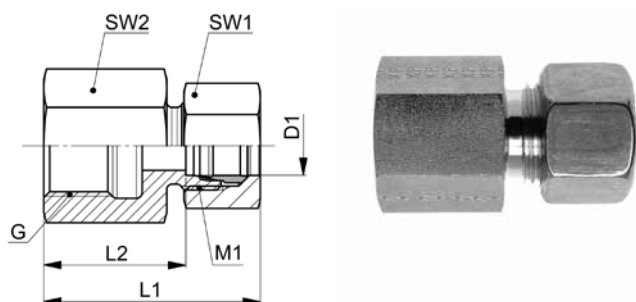

10

GAV-..LR

Type-D1 G	Mat.-Nr.	PN	G	M1	L1	L2	SW1	SW2	g/Stk
G=Rohrgewinde (zylindrisch)			G=BSP thread (parallel)						
						G=rosca de conexión (cilíndrica)			
GAV-06LR 1.8	708.1201.100.20	500	1/8	12x1.5	34.0	19.0	14	14	27
GAV-06LR 1.4	708.1201.110.20	500	1/4	12x1.5	39.0	24.0	14	19	48
GAV-08LR 1.4	708.1201.170.20	500	1/4	14x1.5	39.0	24.0	17	19	50
GAV-08LR 3.8	708.1201.180.20	500	3/8	14x1.5	40.0	25.0	17	24	78
GAV-08LR 1.2	708.1201.185.20	500	1/2	14x1.5	44.0	29.0	17	27	84
GAV-10LR 1.4	708.1201.270.20	500	1/4	16x1.5	40.0	25.0	19	19	60
GAV-10LR 3.8	708.1201.280.20	500	3/8	16x1.5	41.0	26.0	19	24	68
GAV-10LR 1.2	708.1201.285.20	500	1/2	16x1.5	45.0	30.0	19	27	102
GAV-12LR 1.4	708.1201.380.20	400	1/4	18x1.5	40.0	25.0	22	19	68
GAV-12LR 3.8	708.1201.390.20	400	3/8	18x1.5	41.0	26.0	22	24	88
GAV-12LR 1.2	708.1201.400.20	400	1/2	18x1.5	45.0	30.0	22	27	106
GAV-15LR 3.8	708.1201.532.20	400	3/8	22x1.5	42.0	27.0	27	24	114
GAV-15LR 1.2	708.1201.534.20	400	1/2	22x1.5	46.0	31.0	27	27	113
GAV-18LR 3.8	708.1201.644.20	400	3/8	26x1.5	43.0	26.5	32	27	168
GAV-18LR 1.2	708.1201.646.20	400	1/2	26x1.5	47.0	30.5	32	27	151
GAV-22LR 3.4	708.1201.768.20	250	3/4	30x2.0	52.0	35.5	36	36	270
GAV-28LR 1.1	708.1201.850.20	250	1	36x2.0	55.0	38.0	41	41	311
GAV-35LR 5.4	708.1201.944.20	250	1 1/4	45x2.0	63.0	41.0	50	55	588
GAV-42LR 3.2	708.1201.992.20	250	1 1/2	52x2.0	66.0	42.5	60	60	760

Baumaße sind Ungefährmaße bei angezogener Überwurfmutter.

Sizes are approximate dimensions at tightened nut.

Las medidas son aproximadas con la tuerca de unión apretada.

D1=Rohr außen-Ø
M1=metrisches Anschlußgewinde

D1=tube outside diameter
M1=metric connecting thread

D1=Ø exterior del tubo
M1=rosca métrica conexión

Gerade Aufschraubstutzen
Straight female adaptor connectors
Cuerpos atornillables rectos

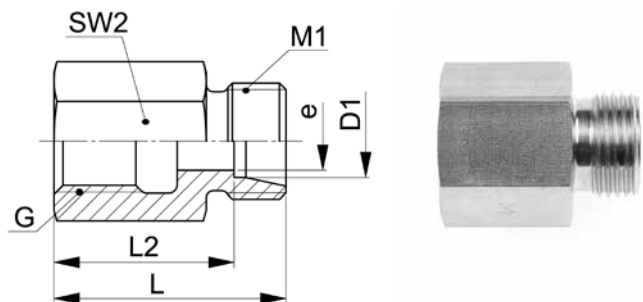

XGAV-..SR

Type-D1 G	Mat.-Nr.	PN	G	M1	L	L2	SW2	e	g/Stk
G=Rohrgewinde (zylindrisch)		G=BSP thread (parallel)			G=rosca de conexión (cilíndrica)				
XGAV-06SR 1.8	706.1201.100.30	800	1/8	14x1.5	28.0	21.0	17	4.0	32
XGAV-06SR 1.4	706.1201.110.30	800	1/4	14x1.5	33.0	26.0	19	4.0	42
XGAV-08SR 1.4	706.1201.170.30	800	1/4	16x1.5	33.0	26.0	19	5.0	44
XGAV-10SR 1.4	706.1201.270.30	800	1/4	18x1.5	34.0	26.5	22	7.0	80
XGAV-10SR 3.8	706.1201.280.30	800	3/8	18x1.5	34.0	26.5	24	7.0	70
XGAV-12SR 1.4	706.1201.380.30	630	1/4	20x1.5	34.5	27.0	22	8.0	70
XGAV-12SR 3.8	706.1201.390.30	630	3/8	20x1.5	34.0	26.5	24	8.0	72
XGAV-12SR 1.2	706.1201.400.30	630	1/2	20x1.5	38.0	30.5	27	8.0	84
XGAV-14SR 1.2	706.1201.504.30	630	1/2	22x1.5	40.0	32.0	27	10.0	94
XGAV-16SR 1.2	706.1201.566.30	630	1/2	24x1.5	40.0	31.5	27	12.0	96
XGAV-20SR 3.8	706.1201.703.30	420	3/8	30x2.0	38.0	27.5	32	14.0	134
XGAV-20SR 1.2	706.1201.706.30	420	1/2	30x2.0	45.0	34.5	32	16.0	154
XGAV-20SR 3.4	706.1201.708.30	420	3/4	30x2.0	45.0	34.5	36	16.0	194
XGAV-25SR 1.1	706.1201.810.30	420	1	36x2.0	49.5	37.5	41	20.0	245
XGAV-30SR 5.4	706.1201.902.30	420	1 1/4	42x2.0	55.5	42.0	55	25.0	514
XGAV-38SR 3.2	706.1201.953.30	420	1 1/2	52x2.0	59.5	43.5	60	32.0	617

D1=Rohr außen-Ø
M1=metrisches Anschlußgewinde
e=kleinster Innen-Ø

D1=tube outside diameter
M1=metric connecting thread
e=minimum inside diameter

D1=Ø exterior del tubo
M1=rosca métrica conexión
e=Ø interior mínimo

Gerade Aufschraubverschraubungen

Straight female adaptor fittings

Racores atornillables rectos

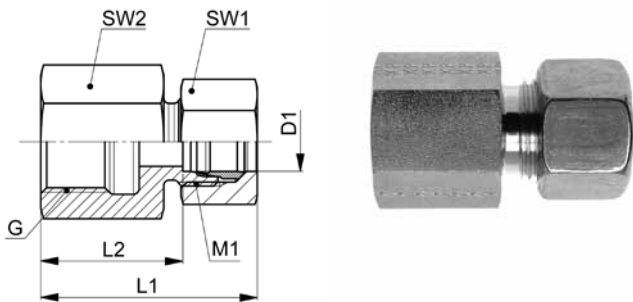

GAV-..SR

Type-D1 G	Mat.-Nr.	PN	G	M1	L1	L2	SW1	SW2	g/Stk
G=Rohrgewinde (zylindrisch)	G=BSP thread (parallel)			G=rosca de conexión (cilíndrica)					
GAV-06SR 1.8	708.1201.100.30	800	1/8	14x1.5	36.0	21.0	17	17	50
GAV-06SR 1.4	708.1201.110.30	800	1/4	14x1.5	41.0	26.0	17	19	49
GAV-08SR 1.4	708.1201.170.30	800	1/4	16x1.5	41.0	26.0	19	19	59
GAV-10SR 1.4	708.1201.270.30	800	1/4	18x1.5	43.0	26.5	22	22	114
GAV-10SR 3.8	708.1201.280.30	800	3/8	18x1.5	43.0	26.5	22	24	100
GAV-12SR 1.4	708.1201.380.30	630	1/4	20x1.5	44.0	27.0	24	22	106
GAV-12SR 3.8	708.1201.390.30	630	3/8	20x1.5	43.0	26.5	24	24	112
GAV-12SR 1.2	708.1201.400.30	630	1/2	20x1.5	47.0	30.5	24	27	122
GAV-14SR 1.2	708.1201.504.30	630	1/2	22x1.5	50.0	32.0	27	27	148
GAV-16SR 1.2	708.1201.566.30	630	1/2	24x1.5	50.0	31.5	30	27	175
GAV-20SR 3.8	708.1201.703.30	420	3/8	30x2.0	51.0	27.5	36	32	245
GAV-20SR 1.2	708.1201.706.30	420	1/2	30x2.0	56.0	34.5	36	32	248
GAV-20SR 3.4	708.1201.708.30	420	3/4	30x2.0	56.0	34.5	36	36	300
GAV-25SR 1.1	708.1201.810.30	420	1	36x2.0	62.0	37.5	46	41	466
GAV-30SR 5.4	708.1201.902.30	420	1 1/4	42x2.0	69.0	42.0	50	55	719
GAV-38SR 3.2	708.1201.953.30	420	1 1/2	52x2.0	75.0	43.5	60	60	980

Baumaße sind Ungefährmaße bei angezogener Überwurfmutter.

Sizes are approximate dimensions at tightened nut.

Las medidas son aproximadas con la tuerca de unión apretada.

D1=Rohr außen-Ø
M1=metrisches Anschlußgewinde

D1=tube outside diameter
M1=metric connecting thread

D1=Ø exterior del tubo
M1=rosca métrica conexión

Gerade Aufschraubstutzen
Straight female adaptor connectors
Cuerpos atornillables rectos

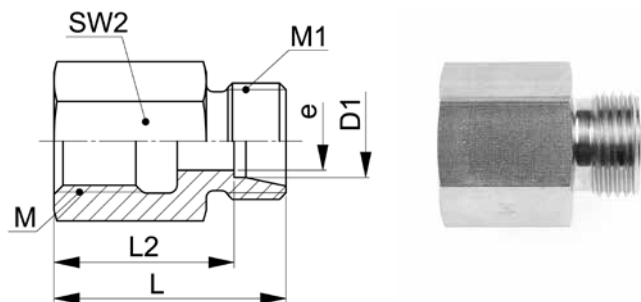

XGAV-..LM/SM

Type -D1 M	Mat.-Nr.	PN	M	M1	L	L2	SW2	e	g/Stk
M=metrisches Gewinde (zylindrisch)		M=metric thread (parallel)			M=rosca métrica (cilíndrica)				
XGAV-06LM 10x1,0	706.1204.180.20	500	10x1.0	12x1.5	26.5	19.5	14	4.0	18
XGAV-08LM 12x1,5	706.1204.240.20	500	12x1.5	14x1.5	31.0	24.0	17	6.0	30
XGAV-10LM 14x1,5	706.1204.280.20	500	14x1.5	16x1.5	32.0	25.0	19	8.0	36
XGAV-12LM 16x1,5	706.1204.330.20	400	16x1.5	18x1.5	33.0	26.0	22	10.0	52
XGAV-12LM 18x1,5	706.1204.333.20	400	18x1.5	18x1.5	35.0	28.0	24	10.0	64
XGAV-12LM 20x1,5	706.1204.335.20	400	20x1.5	18x1.5	35.0	28.0	27	10.0	78
XGAV-15LM 18x1,5	706.1204.390.20	400	18x1.5	26x1.5	35.0	28.0	24	12.0	66
XGAV-18LM 22x1,5	706.1204.460.20	400	22x1.5	26x1.5	37.0	29.5	30	15.0	108
XGAV-22LM 26x1,5	706.1204.535.20	250	26x1.5	30x2.0	42.0	34.5	32	19.0	126
XGAV-28LM 33x2,0	706.1204.570.20	250	33x2.0	36x2.0	45.0	37.5	41	24.0	221
XGAV-35LM 42x2,0	706.1204.600.20	250	42x2.0	45x2.0	51.0	40.5	55	30.0	461
XGAV-42LM 48x2,0	706.1204.992.20	250	48x2.0	52x2.0	53.0	42.0	60	36.0	539
XGAV-06SM 12x1,5	706.1204.190.30	800	12x1.5	14x1.5	33.0	26.0	17	4.0	34
XGAV-08SM 14x1,5	706.1204.198.30	800	14x1.5	16x1.5	33.0	26.0	19	5.0	42
XGAV-10SM 16x1,5	706.1204.285.30	800	16x1.5	18x1.5	34.0	26.5	22	7.0	56
XGAV-12SM 18x1,5	706.1204.333.30	630	18x1.5	20x1.5	35.0	27.5	24	8.0	70
XGAV-12SM 20x1,5	706.1204.335.30	630	20x1.5	20x1.5	37.0	29.5	27	8.0	90
XGAV-14SM 20x1,5	706.1204.382.30	630	20x1.5	22x1.5	39.0	41.0	27	10.0	94
XGAV-16SM 22x1,5	706.1204.410.30	630	22x1.5	24x1.5	39.0	30.5	30	12.0	116
XGAV-20SM 27x2,0	706.1204.506.30	420	27x2.0	30x2.0	45.0	34.5	36	16.0	196
XGAV-25SM 33x2,0	706.1204.550.30	420	33x2.0	36x2.0	49.0	37.0	41	20.0	248

D1=Rohr außen-Ø
M1=metrisches Anschlußgewinde
e=kleinster Innen-Ø

D1=tube outside diameter
M1=metric connecting thread
e=minimum inside diameter

D1=Ø exterior del tubo
M1=rosca métrica conexión
e=Ø interior mínimo

Gerade Aufschraubverschraubungen
Straight female adaptor fittings
Racores atornillables rectos

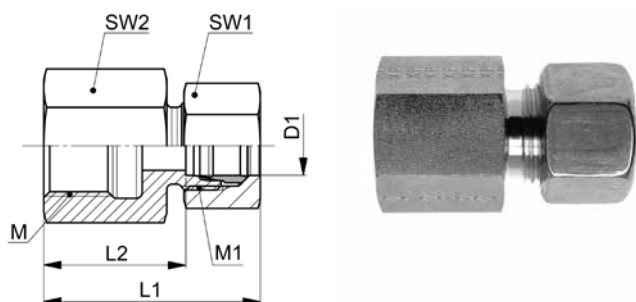

GAV-..LM/SM

Type-D1 M	Mat.-Nr.	PN	M	M1	L1	L2	SW1	SW2	g/Stk
M=metrisches Gewinde (zylindrisch)		M=metric thread (parallel)				M=rosca métrica (cilindrica)			
GAV-06LM 10x1,0	708.1204.180.20	500	10x1.0	12x1.5	34.5	19.5	14	14	26
GAV-08LM 12x1,5	708.1204.240.20	500	12x1.5	14x1.5	39.0	24.0	17	17	50
GAV-10LM 14x1,5	708.1204.280.20	500	14x1.5	16x1.5	40.0	25.0	19	19	50
GAV-12LM 16x1,5	708.1204.330.20	400	16x1.5	18x1.5	41.0	26.0	22	22	90
GAV-12LM 18x1,5	708.1204.333.20	400	18x1.5	18x1.5	43.0	28.0	22	24	95
GAV-12LM 20x1,5	708.1204.335.20	400	20x1.5	18x1.5	43.0	28.0	22	27	110
GAV-15LM 18x1,5	708.1204.390.20	400	18x1.5	22x1.5	43.0	28.0	27	24	115
GAV-18LM 22x1,5	708.1204.460.20	400	22x1.5	26x1.5	46.0	29.5	32	30	157
GAV-22LM 26x1,5	708.1204.535.20	250	26x1.5	30x2.0	51.0	34.5	36	32	215
GAV-28LM 33x2,0	708.1204.570.20	250	33x2.0	36x2.0	54.0	37.5	41	41	320
GAV-35LM 42x2,0	708.1204.600.20	250	42x2.0	45x2.0	62.0	40.5	50	55	620
GAV-42LM 48x2,0	708.1204.992.20	250	48x2.0	52x2.0	65.0	42.0	60	60	780
GAV-06SM 12x1,5	708.1204.190.30	800	12x1.5	14x1.5	41.0	26.0	17	17	54
GAV-08SM 14x1,5	708.1204.198.30	800	14x1.5	16x1.5	41.0	26.0	19	19	69
GAV-10SM 16x1,5	708.1204.285.30	800	16x1.5	18x1.5	43.0	26.5	22	22	102
GAV-12SM 18x1,5	708.1204.333.30	630	18x1.5	20x1.5	44.0	27.5	24	24	110
GAV-12SM 20x1,5	708.1204.335.30	630	20x1.5	20x1.5	46.0	29.5	24	27	125
GAV-14SM 20x1,5	708.1204.382.30	630	20x1.5	22x1.5	49.0	31.0	27	27	148
GAV-16SM 22x1,5	708.1204.410.30	630	22x1.5	24x1.5	49.0	30.5	30	30	175
GAV-20SM 27x2,0	708.1204.506.30	420	27x2.0	30x2.0	56.0	34.5	36	36	307
GAV-25SM 33x2,0	708.1204.550.30	420	33x2.0	36x2.0	61.0	37.0	46	41	466

Baumaße sind Ungefährmaße bei angezogener Überwurfmutter.

Sizes are approximate dimensions at tightened nut.

Las medidas son aproximadas con la tuerca de unión apretada.

D1=Rohr außen-Ø
M1=metrisches Anschlußgewinde

D1=tube outside diameter
M1=metric connecting thread

D1=Ø exterior del tubo
M1=rosca métrica conexión

Manometer-Anschlussstutzen

Abdichtung mit metallischem Dichtkantenring

Manometer connectors

sealing with metal seal-edge ring

Cuerpos para manómetro

junta con anillo con borde de obturación metálico

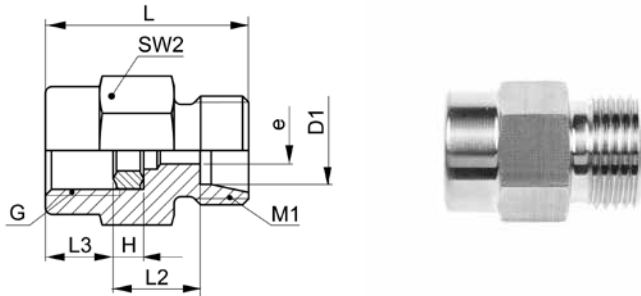

XMAV-..LR/SR DKR

Type-D1 G	Mat.-Nr.	PN	G	M1	H	L	L2	L3	SW2	e	g/Stk	
G=Rohrgewinde (zylindrisch)		G=BSP thread (parallel)				G=rosca de conexión (cilíndrica)						
XMAV-06LR 1.4 DKR	707.0230.110.20	500	1/4	12x1.5	4.5	29.0	12.0	10.0	19	4.0	37	
XMAV-08LR 1.4 DKR	707.0230.170.20	500	1/4	14x1.5	4.5	29.0	12.0	10.0	19	4.0	37	
XMAV-10LR 1.4 DKR	707.0230.270.20	500	1/4	16x1.5	4.5	30.0	13.0	10.0	19	4.0	41	
XMAV-12LR 1.4 DKR	707.0230.380.20	400	1/4	18x1.5	4.5	30.0	13.0	10.0	19	4.0	42	
XMAV-12LR 1.2 DKR	707.0230.400.20	400	1/2	18x1.5	5.0	37.0	15.0	15.0	27	7.0	90	
XMAV-06SR 1.4 DKR	707.0230.110.30	800	1/4	14x1.5	4.5	31.0	14.0	10.0	19	4.0	44	
XMAV-06SR 1.2 DKR	707.0230.125.30	800	1/2	14x1.5	5.0	38.0	16.0	15.0	27	4.0	89	
XMAV-08SR 1.4 DKR	707.0230.170.30	800	1/4	16x1.5	4.5	31.0	14.0	10.0	19	4.0	47	
XMAV-08SR 1.2 DKR	707.0230.185.30	800	1/2	16x1.5	5.0	38.0	16.0	15.0	27	5.0	92	
XMAV-10SR 1.2 DKR	707.0230.285.30	800	1/2	18x1.5	5.0	38.0	15.5	15.0	27	7.0	96	
XMAV-12SR 1.2 DKR	707.0230.400.30	630	1/2	20x1.5	5.0	38.0	15.5	15.0	27	7.0	98	
XMAV-14SR 1.2 DKR	707.0230.504.30	630	1/2	22x1.5	5.0	40.0	17.0	15.0	27	7.0	104	

D1=Rohr außen-Ø
M1=metrisches Anschlußgewinde
e=kleinster Innen-Ø

D1=tube outside diameter
M1=metric connecting thread
e=minimum inside diameter

D1=Ø exterior del tubo
M1=rosca métrica conexión
e=Ø interior mínimo

Manometer-Anschlussverschraubungen

Abdichtung mit metallischem Dichtkantenring

Manometer fittings

sealing with metal seal-edge ring

Racores para manómetro

junta con anillo con borde de obturación metálico

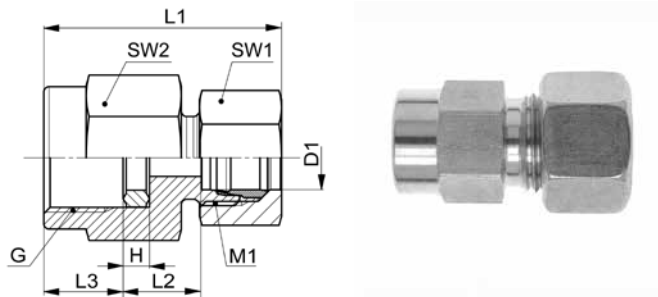

MAV-..LR/SR

Type-D1 G	Mat.-Nr.	PN	G	M1	H	L1	L2	L3	SW1	SW2	g/Stk
G=Rohrgewinde (zylindrisch)		G=BSP thread (parallel)				G=rosca de conexión (cilíndrica)					
MAV-06LR 1.4	708.0230.110.20	500	1/4	12x1.5	4.5	37.0	12.0	10.0	14	19	46
MAV-08LR 1.4	708.0230.170.20	500	1/4	14x1.5	4.5	37.0	12.0	10.0	17	19	53
MAV-10LR 1.4	708.0230.270.20	500	1/4	16x1.5	4.5	38.0	13.0	10.0	19	19	62
MAV-12LR 1.4	708.0230.380.20	400	1/4	18x1.5	4.5	38.0	13.0	10.0	22	19	65
MAV-12LR 1.2	708.0230.400.20	400	1/2	18x1.5	5.0	45.0	15.0	15.0	22	27	105
MAV-06SR 1.4	708.0230.110.30	800	1/4	14x1.5	4.5	39.0	14.0	10.0	17	19	62
MAV-06SR 1.2	708.0230.125.30	800	1/2	14x1.5	5.0	46.0	16.0	15.0	17	27	110
MAV-08SR 1.4	708.0230.170.30	800	1/2	16x1.5	5.0	46.0	16.0	15.0	19	27	115
MAV-08SR 1.2	708.0230.185.30	800	1/4	16x1.5	4.5	39.0	14.0	10.0	19	19	68
MAV-10SR 1.2	708.0230.285.30	800	1/2	18x1.5	5.0	47.0	15.5	15.0	22	27	120
MAV-12SR 1.2	708.0230.400.30	630	1/2	20x1.5	5.0	47.0	15.5	15.0	24	27	136
MAV-14SR 1.2	708.0230.504.30	630	1/2	22x1.5	5.0	50.0	17.0	15.0	27	27	158

Baumaße sind Ungefährmaße bei angezogener Überwurfmutter.

Sizes are approximate dimensions at tightened nut.

Las medidas son aproximadas con la tuerca de unión apretada.

D1=Rohr außen-Ø
M1=metrisches Anschlußgewinde

D1=tube outside diameter
M1=metric connecting thread

D1=Ø exterior del tubo
M1=rosca métrica conexión

Manometer-Anschlussstutzen NPT

Manometer connectors NPT

Cuerpos para manómetro NPT

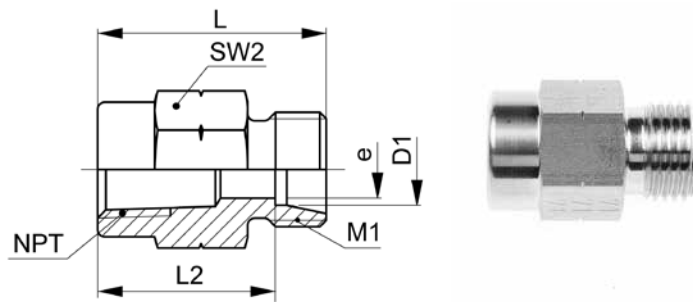

XMAV-..LNPT/SNPT

Type -D1 NPT	Mat.-Nr.	PN	NPT	M1	L	L2	SW2	e	g/Stk
NPT=Einschraubgewinde NPT		NPT=tapered male adaptor thread NPT			NPT=rosca de conexión cónica NPT				
XMAV-06LNPT 1.4	706.0231.110.20	500	1/4	12x1.5	30.0	23.0	19	4.0	39
XMAV-06LNPT 1.2	706.0231.125.20	500	1/2	12x1.5	38.0	31.0	27	4.0	93
XMAV-08LNPT 1.4	706.0231.170.20	500	1/4	14x1.5	30.0	23.0	19	6.0	40
XMAV-08LNPT 1.2	706.0231.185.20	500	1/2	14x1.5	38.0	31.0	27	6.0	94
XMAV-10LNPT 1.4	706.0231.270.20	500	1/4	16x1.5	32.0	25.0	19	8.0	44
XMAV-10LNPT 1.2	706.0231.285.20	500	1/2	16x1.5	39.0	32.0	27	8.0	96
XMAV-12LNPT 1.4	706.0231.380.20	400	1/4	18x1.5	32.0	25.0	19	10.0	45
XMAV-12LNPT 1.2	706.0231.400.20	400	1/2	18x1.5	39.0	32.0	27	10.0	97
XMAV-06SNPT 1.2	706.0231.125.30	800	1/2	14x1.5	40.0	33.0	27	4.0	98
XMAV-08SNPT 1.2	706.0231.185.30	800	1/2	16x1.5	40.0	33.0	27	5.0	100
XMAV-12SNPT 1.2	706.0231.400.30	630	1/2	20x1.5	40.0	32.5	27	8.0	105

D1=Rohr außen-Ø
M1=metrisches Anschlußgewinde
e=kleinster Innen-Ø

D1=tube outside diameter
M1=metric connecting thread
e=minimum inside diameter

D1=Ø exterior del tubo
M1=rosca métrica conexión
e=Ø interior mínimo

Manometer-Anschlussverschraubungen NPT
Manometer fittings NPT
Racores para manómetro NPT

10

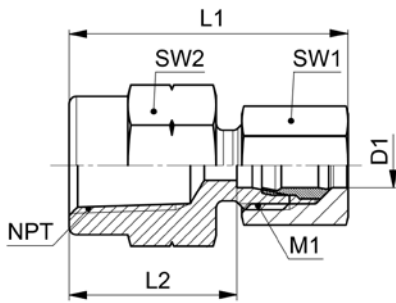

MAV-..LNPT/SNPT

Type-D1 NPT	Mat.-Nr.	PN	NPT	M1	L1	L2	SW1	SW2	g/Stk
NPT=Einschraubgewinde NPT		NPT=tapered male adaptor thread NPT			NPT=rosca de conexión cónica NPT				
MAV-06LNPT 1.4	708.0231.110.20	500	1/4	12x1.5	38.0	23.0	14	19	50
MAV-06LNPT 1.2	708.0231.125.20	500	1/2	12x1.5	46.0	31.0	14	27	104
MAV-08LNPT 1.4	708.0231.170.20	500	1/4	14x1.5	38.0	23.0	17	19	56
MAV-08LNPT 1.2	708.0231.185.20	500	1/2	14x1.5	46.0	31.0	17	27	110
MAV-10LNPT 1.4	708.0231.270.20	500	1/4	16x1.5	40.0	25.0	19	19	65
MAV-10LNPT 1.2	708.0231.285.20	500	1/2	16x1.5	47.0	32.0	19	27	117
MAV-12LNPT 1.4	708.0231.380.20	400	1/4	18x1.5	40.0	25.0	22	19	73
MAV-12LNPT 1.2	708.0231.400.20	400	1/2	18x1.5	47.0	32.0	22	27	125
MAV-06SNPT 1.2	708.0231.125.30	800	1/2	14x1.5	48.0	33.0	17	27	117
MAV-08SNPT 1.2	708.0231.185.30	800	1/2	16x1.5	48.0	33.0	19	27	122
MAV-12SNPT 1.2	708.0231.400.30	630	1/2	20x1.5	49.0	32.5	24	27	142

Baumaße sind Ungefährmaße bei angezogener Überwurfmutter.

Sizes are approximate dimensions at tightened nut.

Las medidas son aproximadas con la tuerca de unión apretada.

D1=Rohr außen-Ø
M1=metrisches Anschlußgewinde

D1=tube outside diameter
M1=metric connecting thread

D1=Ø exterior del tubo
M1=rosca métrica conexión

EXMAR CAD Bibliothek –

- technische Daten und Zeichnungen von Katalogartikel
- kostenfreie Downloads
- im benötigten CAD-Format

EXMAR CAD Library –

- technical data and drawings of catalog items
- free downloads
- in the desired CAD format

Biblioteca CAD de EXMAR –

- datos técnicos y planos de los artículos del catálogo
- descargas gratuitas
- en el formato CAD requerido

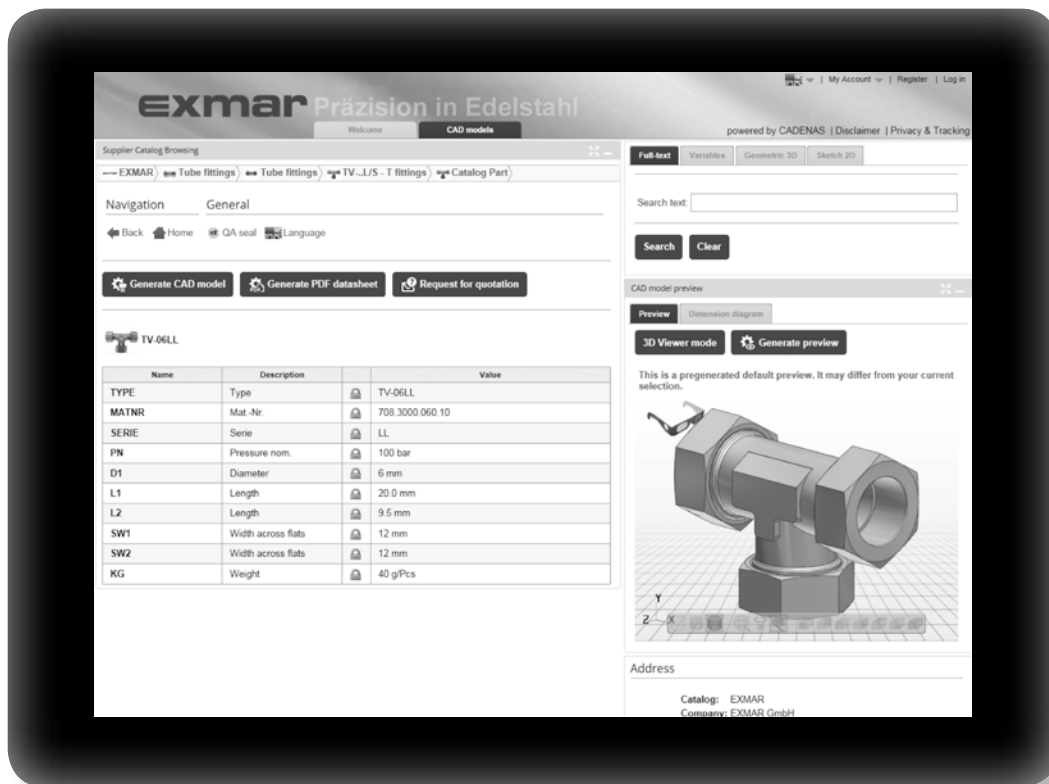

exmar.partcommunity.com

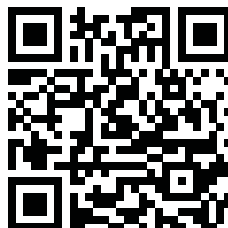

Einstellbare Manometerverschraubungen mit Dichtkegel und O-Ring

Abdichtung mit metallischem Dichtkantenring

Adjustable manometer fittings with taper and O-ring

sealing with metal seal-edge ring

Racores para manómetro ajustables con junta cónica y junta tórica

junta con anillo con borde de obturación metálico

10

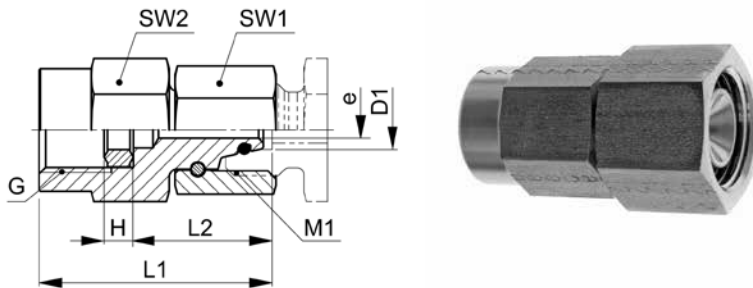

EMAKO-..LR/SR

Type-D1 G	Mat.-Nr.	PN	G	M1	H	L1	L2	SW1	SW2	e	g/Stk
G=Rohrgewinde (zylindrisch)		G=BSP thread (parallel)			G=rosca de conexión (cilíndrica)						
EMAKO-06LR 1.4	708.0245.110.20	315	1/4	12x1.5	4.5	35.5	21.5	14	19	2.5	45
EMAKO-08LR 1.4	708.0245.170.20	315	1/4	14x1.5	4.5	35.5	21.5	17	19	4.0	57
EMAKO-10LR 1.4	708.0245.270.20	315	1/4	16x1.5	4.5	36.0	21.5	19	19	5.5	63
EMAKO-12LR 1.4	708.0245.380.20	315	1/4	18x1.5	4.5	36.0	21.5	22	19	5.5	75
EMAKO-06SR 1.4	708.0245.110.30	630	1/4	14x1.5	4.5	36.0	21.5	17	19	2.5	54
EMAKO-06SR 1.2	708.0245.125.30	630	1/2	14x1.5	5.0	42.5	23.0	17	27	2.5	110
EMAKO-08SR 1.4	708.0245.170.30	630	1/4	16x1.5	4.5	37.5	23.0	19	19	4.0	62
EMAKO-08SR 1.2	708.0245.185.30	630	1/2	16x1.5	5.0	43.0	23.5	19	27	4.0	112
EMAKO-10SR 1.4	708.0245.270.30	630	1/4	18x1.5	4.5	37.5	27.5	22	19	7.0	76
EMAKO-10SR 1.2	708.0245.285.30	630	1/2	18x1.5	5.0	43.5	24.0	22	27	6.0	123
EMAKO-12SR 1.4	708.0245.380.30	630	1/4	20x1.5	4.5	39.5	25.0	24	19	7.0	120
EMAKO-12SR 1.2	708.0245.400.30	630	1/2	20x1.5	5.0	45.0	25.5	24	27	7.0	139

Baumaße sind Ungefährmaße bei angezogener Überwurfmutter.

Sizes are approximate dimensions at tightened nut.

Las medidas son aproximadas con la tuerca de unión apretada.

Dichtungsmaterial: FKM (andere Werkstoffe auf Anfrage)

Sealing material: FKM (other materials on request)

Material de junta tórica: FKM (otros materiales bajo demanda)

D1=Rohr außen-Ø
M1=metrisches Anschlußgewinde
e=kleinster Innen-Ø

D1=tube outside diameter
M1=metric connecting thread
e=minimum inside diameter

D1=Ø exterior del tubo
M1=rosca métrica conexión
e=Ø interior mínimo

Einstellbare Manometer-Anschlussstutzen

Abdichtung mit metallischem Dichtkantenring

Adjustable manometer connectors

sealing with metal seal-edge ring

Cuerpos para manómetro ajustables

junta con anillo con borde de obturación metálico

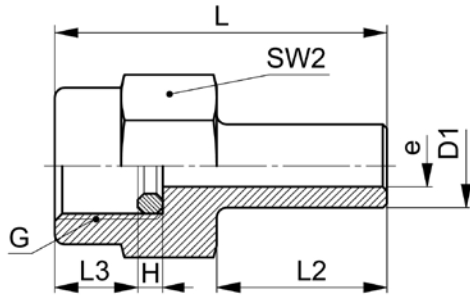

XEMAS-..LR/SR DKR

Type-D1 G	Mat.-Nr.	PN	G	H	L	L2	L3	SW2	e	g/Stk
G=Rohrgewinde (zylindrisch)		G=BSP thread (parallel)				G=rosca de conexión (cilíndrica)				
XEMAS-06LR / SR 1.4 DKR	707.0235.110.13	800	1/4	4.5	38.0	18.5	8.5	19	3.5	37
XEMAS-06LR / SR 1.2 DKR	707.0235.125.13	800	1/2	5.0	48.0	18.5	15.0	27	3.5	100
XEMAS-08LR / SR 1.4 DKR	707.0235.170.13	800	1/4	4.5	38.0	19.5	8.5	19	5.0	36
XEMAS-08LR / SR 1.2 DKR	707.0235.185.13	800	1/2	5.0	50.0	20.5	15.0	27	4.5	102
XEMAS-10LR / SR 1.4 DKR	707.0235.270.13	800	1/4	4.5	40.0	20.5	8.5	19	5.0	44
XEMAS-10LR / SR 1.2 DKR	707.0235.285.13	800	1/2	5.0	50.0	21.5	15.0	27	6.5	99
XEMAS-12LR / SR 1.4 DKR	707.0235.380.13	630	1/4	4.5	40.0	20.5	8.5	19	5.0	49
XEMAS-12LR / SR 1.2 DKR	707.0235.400.13	630	1/2	5.0	47.5	22.5	15.0	27	7.5	90

D1=Rohr außen-Ø
e=kleinster Innen-Ø

D1=tube outside diameter
e=minimum inside diameter

D1=Ø exterior del tubo
e=Ø interior mínimo

Einstellbare Manometer-Anschlussstutzen

schaftseitig vormontiert, Abdichtung mit metallischem Dichtkantenring

Adjustable manometer fittings

pre-assembled on standpipe side, sealing with metal seal-edge ring

Racores para manómetro ajustables

premontado en lado de vástago, junta con anillo con borde de obturación metálico

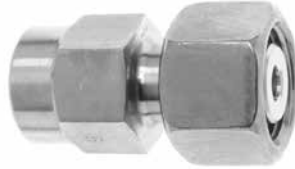
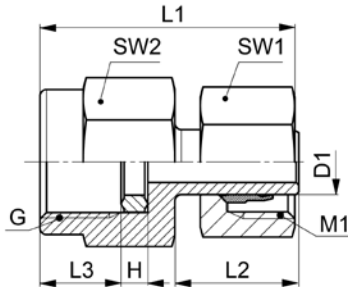

EMAS-..LR/SR

Type-D1 G	Mat.-Nr.	PN	G	M1	H	L1	L2	L3	SW1	SW2	g/Stk
G=Rohrgewinde (zylindrisch)		G=BSP thread (parallel)				G=rosca de conexión (cilíndrica)					
EMAS-06LR 1.4	708.0235.110.21	500	1/4	12x1.5	4.5	38.5	18.5	8.5	14	19	46
EMAS-06LR 1.2	708.0235.125.21	500	1/2	12x1.5	5.0	38.5	18.5	15.0	14	27	112
EMAS-08LR 1.4	708.0235.170.21	500	1/4	14x1.5	4.5	38.5	19.5	8.5	17	19	53
EMAS-08LR 1.2	708.0235.185.21	500	1/2	14x1.5	5.0	50.0	20.5	15.0	17	27	120
EMAS-10LR 1.4	708.0235.270.21	500	1/4	16x1.5	4.5	41.0	20.5	8.5	19	19	62
EMAS-10LR 1.2	708.0235.285.21	500	1/2	16x1.5	5.0	50.0	21.5	15.0	19	27	122
EMAS-12LR 1.4	708.0235.380.21	400	1/4	18x1.5	4.5	40.5	20.5	8.5	22	19	70
EMAS-12LR 1.2	708.0235.400.21	400	1/2	18x1.5	5.0	47.5	22.5	15.0	22	27	117
EMAS-06SR 1.4	708.0235.110.31	800	1/4	14x1.5	4.5	38.0	18.5	8.5	17	19	57
EMAS-06SR 1.2	708.0235.125.31	800	1/2	14x1.5	5.0	48.5	18.5	15.0	17	27	105
EMAS-08SR 1.4	708.0235.170.31	800	1/4	16x1.5	4.5	38.0	19.5	8.5	19	19	60
EMAS-08SR 1.2	708.0235.185.31	800	1/2	16x1.5	5.0	50.5	20.5	15.0	19	27	107
EMAS-10SR 1.4	708.0235.270.31	800	1/4	18x1.5	4.5	40.0	20.5	8.5	22	19	80
EMAS-10SR 1.2	708.0235.285.31	800	1/2	18x1.5	5.0	50.0	21.5	15.0	22	27	125
EMAS-12SR 1.4	708.0235.380.31	630	1/4	20x1.5	4.5	40.0	20.5	8.5	24	19	90
EMAS-12SR 1.2	708.0235.400.31	630	1/2	20x1.5	5.0	47.0	22.5	15.0	24	27	134

Baumaße sind Ungefährmaße bei angezogener Überwurfmutter.

Sizes are approximate dimensions at tightened nut.

Las medidas son aproximadas con la tuerca de unión apretada.

Achtung: Für Endmontage des vormontierten Schaftes Überwurfmutter mit 1/4 Umdrehung über den Punkt des deutlich fühlbaren Kraftanstiegs anziehen.

Attention: For final assembly of the pre-assembled standpipe, tighten the union nut by 1/4 turn beyond the point of the clearly perceptible increase in force.

Atención: Para el ensamblaje final del vástago premontado, apriete la tuerca de unión 1/4 de vuelta más allá del punto del aumento claramente perceptible de la resistencia.

D1=Rohr außen-Ø
M1=metrisches Anschlußgewinde

D1=tube outside diameter
M1=metric connecting thread

D1=Ø exterior del tubo
M1=rosca métrica conexión

Einstellbare Manometer-Anschlussstutzen NPT
Adjustable manometer connectors NPT
Cuerpos para manómetro ajustables NPT

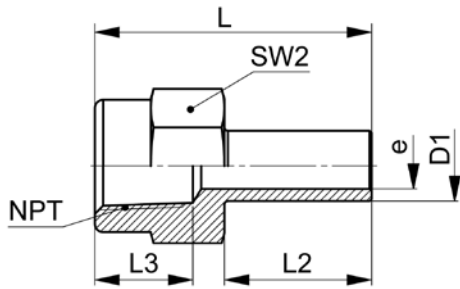

XEMAS-..LNPT/SNPT

Type -D1 NPT	Mat.-Nr.	PN	NPT	L	L2	L3	SW2	e	g/Stk
NPT=Einschraubgewinde NPT		NPT=tapered male adaptor thread NPT			NPT=rosca de conexión cónica NPT				
XEMAS-06LNPT 1.4	706.0236.110.20	500	1/4	38.0	19.5	14.0	19	3.2	35
XEMAS-08LNPT 1.4	706.0236.170.20	500	1/4	38.0	21.0	14.0	19	5.0	33
XEMAS-10LNPT 1.4	706.0236.270.20	500	1/4	39.5	21.0	14.0	19	6.5	39
XEMAS-12LNPT 1.4	706.0236.380.20	400	1/4	40.5	21.0	14.0	19	8.0	44
XEMAS-06SNPT 1.2	706.0236.125.30	800	1/2	45.0	20.0	18.0	27	3.2	85
XEMAS-08SNPT 1.2	706.0236.185.30	800	1/2	46.0	21.0	18.0	27	4.0	88
XEMAS-10SNPT 1.2	706.0236.285.30	800	1/2	47.0	22.0	18.0	27	6.0	90
XEMAS-12SNPT 1.2	706.0236.400.30	630	1/2	47.5	22.5	18.0	27	7.0	94

D1=Rohr außen-Ø
 e=kleinster Innen-Ø

D1=tube outside diameter
 e=minimum inside diameter

D1=Ø exterior del tubo
 e=Ø interior mínimo

Einstellbare Manometer-Anschlussstutzen NPT

schaftseitig vormontiert

Adjustable manometer fittings NPT

pre-assembled on standpipe side

Racores para manómetro ajustables NPT

premontado en lado de vástago

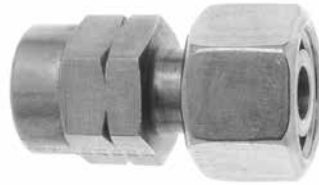
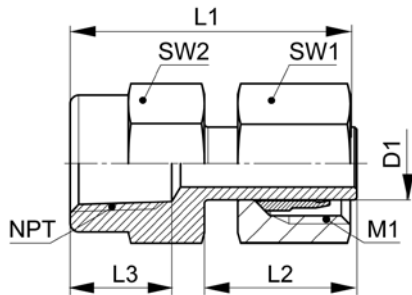

EMAS-..LNPT/SNPT

Type-D1 NPT	Mat.-Nr.	PN	NPT	M1	L1	L2	L3	SW1	SW2	g/Stk
NPT=Einschraubgewinde NPT		NPT=tapered male adaptor thread NPT			NPT=rosca de conexión cónica NPT					
EMAS-06LNPT 1.4	708.0236.110.21	500	1/4	12x1.5	38.0	19.5	14.0	14	19	48
EMAS-08LNPT 1.4	708.0236.170.21	500	1/4	14x1.5	38.0	21.0	14.0	17	19	54
EMAS-10LNPT 1.4	708.0236.270.21	500	1/4	16x1.5	39.5	21.0	14.0	19	19	62
EMAS-12LNPT 1.4	708.0236.380.21	400	1/4	18x1.5	40.5	21.0	14.0	22	19	76
EMAS-06SNPT 1.2	708.0236.125.31	800	1/2	14x1.5	45.0	20.0	18.0	17	27	104
EMAS-08SNPT 1.2	708.0236.185.31	800	1/2	16x1.5	46.0	21.0	18.0	19	27	110
EMAS-10SNPT 1.2	708.0236.285.31	800	1/2	18x1.5	47.0	22.0	18.0	22	27	123
EMAS-12SNPT 1.2	708.0236.400.31	630	1/2	20x1.5	47.5	22.5	18.0	24	27	132

Baumaße sind Ungefährmaße bei angezogener Überwurfmutter.

Achtung: Für Endmontage des vormontierten Schaftes Überwurfmutter mit 1/4 Umdrehung über den Punkt des deutlich fühlbaren Kraftanstiegs anziehen.

Sizes are approximate dimensions at tightened nut.

Attention: For final assembly of the pre-assembled standpipe, tighten the union nut by 1/4 turn beyond the point of the clearly perceptible increase in force.

Las medidas son aproximadas con la tuerca de unión apretada.

Atención: Para el ensamblaje final del vástago premontado, apriete la tuerca de unión 1/4 de vuelta más allá del punto del aumento claramente perceptible de la resistencia.

D1=Rohr außen-Ø
M1=metrisches Anschlußgewinde

D1=tube outside diameter
M1=metric connecting thread

D1=Ø exterior del tubo
M1=rosca métrica conexión

Gerade Messstutzen

mit Schraubkupplung M16x2 und O-Ring, Kegelausführung

Straight connectors with test gauge

with threaded connection M16x2 and O-ring, tapered version

Cuerpos de medición rectos

con acoplamiento roscado M16x2 y junta tórica, versión cónico

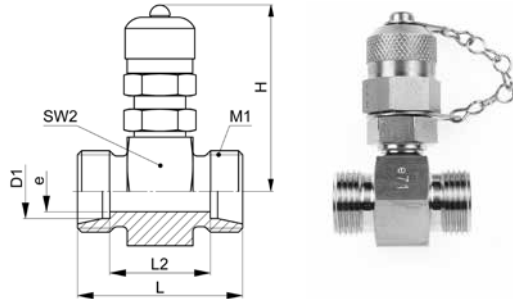

XEMV-GV-..L/S

Type-D1	Mat.-Nr.	PN	M1	H	L	L2	SW2	e	g/Stk
XEMV-GV06L	707.0240.060.20	315	12x1.5	49.0	34.5	20.0	24	4.0	125
XEMV-GV08L	707.0240.080.20	315	14x1.5	49.0	34.5	20.0	24	4.0	127
XEMV-GV10L	707.0240.100.20	315	16x1.5	49.0	36.5	22.0	24	7.0	131
XEMV-GV12L	707.0240.120.20	315	18x1.5	49.0	36.5	22.0	24	9.0	132
XEMV-GV15L	707.0240.150.20	315	22x1.5	52.0	38.5	24.0	30	12.0	171
XEMV-GV18L	707.0240.180.20	315	26x1.5	53.0	38.5	23.0	32	15.0	189
XEMV-GV22L	707.0240.220.20	160	30x2.0	55.0	42.5	27.0	36	19.0	222
XEMV-GV28L	707.0240.280.20	160	36x2.0	57.0	42.5	27.0	41	23.0	269
XEMV-GV35L	707.0240.350.20	160	45x2.0	57.0	46.5	25.0	50	30.0	377
XEMV-GV42L	707.0240.420.20	160	52x2.0	64.0	46.5	24.0	55	36.0	421
XEMV-GV06S	707.0240.060.30	630	14x1.5	49.0	38.5	24.0	24	4.0	136
XEMV-GV08S	707.0240.080.30	630	16x1.5	49.0	38.5	24.0	24	5.0	140
XEMV-GV10S	707.0240.100.30	630	18x1.5	49.0	38.5	23.0	24	7.0	143
XEMV-GV12S	707.0240.120.30	630	20x1.5	49.0	38.5	23.0	24	8.0	149
XEMV-GV14S	707.0240.140.30	630	22x1.5	50.0	42.5	26.0	27	9.0	176
XEMV-GV16S	707.0240.160.30	420	24x1.5	52.0	42.5	25.0	30	12.0	191
XEMV-GV20S	707.0240.200.30	420	30x2.0	55.0	46.5	25.0	36	16.0	256
XEMV-GV25S	707.0240.250.30	420	36x2.0	57.0	50.5	26.0	41	20.0	334
XEMV-GV30S	707.0240.300.30	420	42x2.0	60.0	54.5	27.0	46	25.0	421
XEMV-GV38S	707.0240.380.30	420	52x2.0	64.0	61.0	28.5	55	32.0	637

mit O-Ring-Dichtung am Einschraubgewinde
Dichtungsmaterial: FKM (andere Werkstoffe auf Anfrage)

with O-ring-seal on male adaptor thread
Sealing material: FKM (other materials on request)

con junta tórica en la rosca
Material de junta tórica: FKM (otros materiales bajo demanda).

D1=Rohr außen-Ø
M1=metrisches Anschlußgewinde
e=kleinster Innen-Ø

D1=tube outside diameter
M1=metric connecting thread
e=minimum inside diameter

D1=Ø exterior del tubo
M1=rosca métrica conexión
e=Ø interior mínimo

Gerade Messverschraubungen

mit Schraubkupplung M16x2 und O-Ring, Kegelausführung

Straight fittings with test gauge

with threaded connection M16x2 and O-ring, tapered version

Racores de medición rectos

con acoplamiento roscado M16x2 y junta tórica, versión cónico

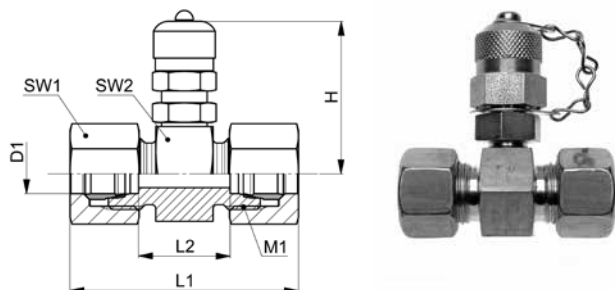

EMV-GV-..L/S

Type-D1	Mat.-Nr.	PN	M1	H	L1	L2	SW1	SW2	g/Stk
EMV-GV-06L	708.0240.060.20	315	12x1.5	49.0	50.5	20.0	14	24	149
EMV-GV-08L	708.0240.080.20	315	14x1.5	49.0	50.5	20.0	17	24	161
EMV-GV-10L	708.0240.100.20	315	16x1.5	49.0	52.5	22.0	19	24	175
EMV-GV-12L	708.0240.120.20	315	18x1.5	49.0	52.5	22.0	22	24	186
EMV-GV-15L	708.0240.150.20	315	22x1.5	52.0	54.5	24.0	27	30	261
EMV-GV-18L	708.0240.180.20	315	26x1.5	53.0	56.5	23.0	32	32	323
EMV-GV-22L	708.0240.220.20	160	30x2.0	55.0	60.5	27.0	36	36	396
EMV-GV-28L	708.0240.280.20	160	36x2.0	57.0	60.5	27.0	41	41	458
EMV-GV-35L	708.0240.350.20	160	45x2.0	60.0	63.5	25.0	50	50	695
EMV-GV-42L	708.0240.420.20	160	52x2.0	64.0	70.5	24.0	60	55	903
EMV-GV-06S	708.0240.060.30	630	14x1.5	49.0	54.5	24.0	17	24	172
EMV-GV-08S	708.0240.080.30	630	16x1.5	49.0	54.5	24.0	19	24	182
EMV-GV-10S	708.0240.100.30	630	18x1.5	49.0	56.5	23.0	22	24	207
EMV-GV-12S	708.0240.120.30	630	20x1.5	49.0	56.5	23.0	24	24	223
EMV-GV-14S	708.0240.140.30	630	22x1.5	50.0	62.5	26.0	27	27	284
EMV-GV-16S	708.0240.160.30	420	24x1.5	52.0	62.5	25.0	30	30	327
EMV-GV-20S	708.0240.200.30	420	30x2.0	55.0	68.5	25.0	36	36	478
EMV-GV-25S	708.0240.250.30	420	36x2.0	57.0	74.5	26.0	46	41	776
EMV-GV-30S	708.0240.300.30	420	42x2.0	60.0	80.5	27.0	50	46	907
EMV-GV-38S	708.0240.380.30	420	52x2.0	64.0	91.0	28.5	60	55	1347

Baumaße sind Ungefährmaße bei angezogener Überwurfmutter.

Sizes are approximate dimensions at tightened nut.

Las medidas son aproximadas con la tuerca de unión apretada.

mit O-Ring-Dichtung am Einschraubgewinde
Dichtungsmaterial: FKM (andere Werkstoffe auf Anfrage)

with O-ring-seal on male adaptor thread
Sealing material: FKM (other materials on request)

Junta tórica en la rosca
Material de junta tórica: FKM (otros materiales bajo demanda)

D1=Rohr außen-Ø
M1=metrisches Anschlußgewinde

D1=tube outside diameter
M1=metric connecting thread

D1=Ø exterior del tubo
M1=rosca métrica conexión

Messanschlüsse

mit Schraubkupplung M16x2, Kegelausführung

Test point gauges

with threaded connection M16x2, tapered version

Conexiones de medición

con acoplamiento roscado M16x2, versión cónico

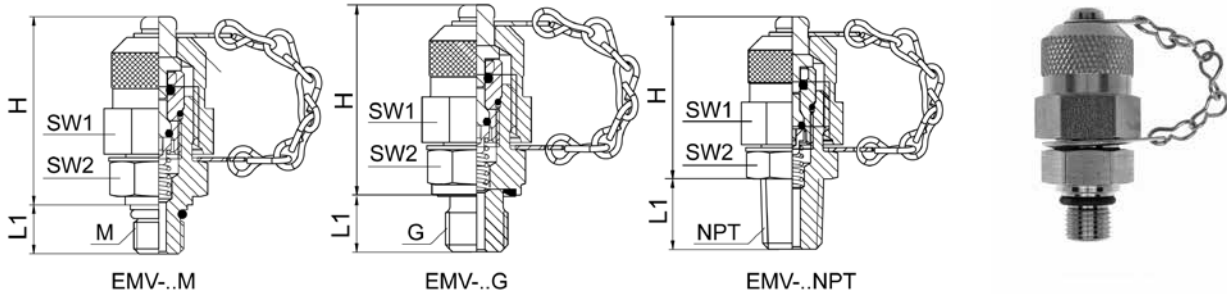

EMV-..

Type -M	Mat.-Nr.	PN	M	H	L1	SW1	SW2	g/Stk
M=metrisches Gewinde (zylindrisch)	M=metric thread (parallel)	M=rosca métrica (cilíndrica)						
EMV-M 10x1,0	706.0246.150.30	630	10x1.0	38.0	10.0	19	17	66

mit O-Ring-Dichtung am Einschraubgewinde
Dichtungsmaterial: FKM (andere Werkstoffe auf Anfrage)

with O-ring-seal on male adaptor thread
Sealing material: FKM (other materials on request)

con junta tórica en la rosca
Material de junta tórica: FKM (otros materiales bajo demanda).

Type -G	Mat.-Nr.	PN	G	H	L1	SW1	SW2	g/Stk
G=Rohrgewinde (zylindrisch)	G=BSP thread (parallel)	G=rosca de conexión (cilíndrica)						
EMV-G 1.4A WD	706.0249.040.30	630	1/4	37.0	12.0	19	17	70

Dichtungsmaterial: FKM (andere Werkstoffe auf Anfrage)

Sealing material: FKM (other materials on request)

Material de junta tórica: FKM (otros materiales bajo demanda).

Type -NPT	Mat.-Nr.	PN	NPT	H	L1	SW1	SW2	g/Stk
NPT=Einschraubgewinde NPT	NPT=tapered male adaptor thread NPT	NPT=rosca de conexión cónica NPT						
EMV-NPT 1.8	706.0247.020.30	400	1/8	36.0	9.5	19	17	70
EMV-NPT 1.4	706.0247.040.30	630	1/4	35.0	14.0	19	17	70

Messanschlüsse für 24° Konen

mit Schraubkupplung M16x2 und O-Ring, Kegelausführung

Test point gauges for 24° taper

with threaded connection M16x2 and O-ring, tapered version

Conexiones de medición para conos de 24°

con acoplamiento roscado M16x2 y junta tórica, versión cónico

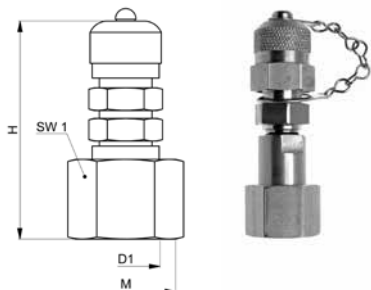

EMV-..L/S

Type-D1	Mat.-Nr.	PN	M	H	SW1	g/Stk
M=metrisches Gewinde (zylindrisch)	M=metric thread (parallel)	M=rosca métrica (cilindrica)				
Δ EMV-06L	708.0243.060.20	500	12x1.5	64.0	14	114
Δ EMV-08L	708.0243.080.20	500	14x1.5	64.0	17	116
Δ EMV-10L	708.0243.100.20	500	16x1.5	65.0	19	127
Δ EMV-12L	708.0243.120.20	400	18x1.5	65.0	22	144
EMV-15L	708.0243.150.20	400	22x1.5	52.0	27	130
EMV-18L	708.0243.180.20	400	26x1.5	55.0	32	161
EMV-22L	708.0243.220.20	250	30x2.0	55.0	36	202
EMV-28L	708.0243.280.20	250	36x2.0	55.0	41	261
EMV-35L	708.0243.350.20	250	45x2.0	57.0	50	394
EMV-42L	708.0243.420.20	250	52x2.0	57.0	60	570
Δ EMV-06S	708.0243.060.30	630	14x1.5	64.0	17	116
Δ EMV-08S	708.0243.080.30	630	16x1.5	65.0	19	128
Δ EMV-10S	708.0243.100.30	630	18x1.5	65.0	22	144
Δ EMV-12S	708.0243.120.30	630	20x1.5	68.0	24	162
Δ EMV-14S	708.0243.140.30	630	22x1.5	52.0	27	135
EMV-16S	708.0243.160.30	630	24x1.5	52.0	30	158
EMV-20S	708.0243.200.30	420	30x2.0	57.0	36	227
EMV-25S	708.0243.250.30	420	36x2.0	58.0	46	375
EMV-30S	708.0243.300.30	420	42x2.0	60.0	50	447
EMV-38S	708.0243.380.30	420	52x2.0	62.0	60	683

mit O-Ring-Dichtung am Einschraubgewinde
Dichtungsmaterial: FKM (andere Werkstoffe auf Anfrage)

with O-ring-seal on male adaptor thread
Sealing material: FKM (other materials on request)

con junta tórica en la rosca
Material de junta tórica: FKM (otros materiales bajo demanda).

D1=Rohr außen-Ø
Δ=Ausführung mit Dichtkegel

D1=tube outside diameter
Δ=Version with taper

D1=Ø exterior del tubo
Δ=Versión con junta cónica

EXMAR Online Shop

- tagesaktuelle Daten und Preise
- Bestellung per Klick rund um die Uhr
- Zugriff auf Bestellhistorie

EXMAR Online Shop

- daily updated data and prices
- just click to order, any time of the day
- access to order history

EXMAR Online Shop

- datos y precios más actualizados
- pedidos con un solo clic, cualquier hora del día
- acceso al historial de pedidos

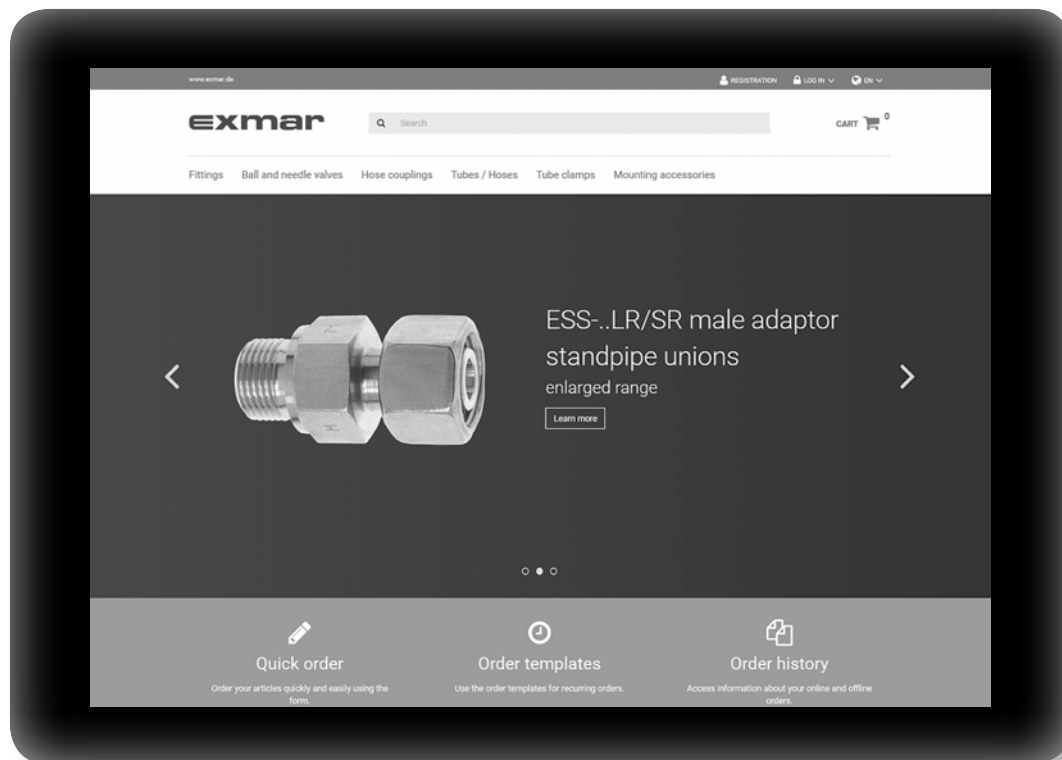

www.shop.exmar.de

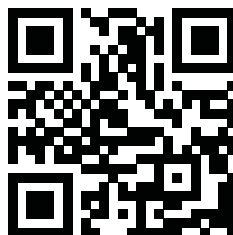

Gerade Zwischenreduzierstutzen mit Dichtkegel und O-Ring
Straight reducing unions with taper and O-ring
Racores de reducción rectos con junta cónica y junta tórica

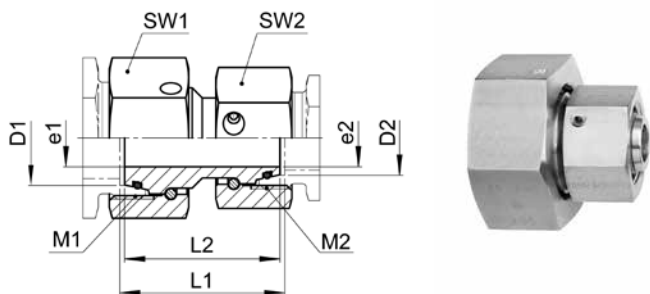

10

VKOR-..L

Type -D1 /D2	Mat.-Nr.	PN	M1	M2	L1	L2	SW1	SW2	e1	e2	g/Stk
VKOR-10/08L	708.1074.190.21	315	16x1.5	14x1.5	35.0	32.5	19	17	6.0	4.0	52
VKOR-12/06L	708.1074.215.21	315	18x1.5	12x1.5	34.0	33.0	22	17	3.0	3.0	56
VKOR-15/10L	708.1074.410.21	315	22x1.5	16x1.5	39.0	38.0	27	19	10.0	6.0	101
VKOR-18/10L	708.1074.575.21	315	26x1.5	16x1.5	37.5	36.0	32	19	6.0	6.0	125
VKOR-18/12L	708.1074.580.21	315	26x1.5	18x1.5	37.5	36.0	32	22	8.0	8.0	132
VKOR-18/15L	708.1074.610.21	315	26x1.5	22x1.5	39.5	37.5	32	27	10.0	10.0	175
VKOR-22/15L	708.1074.745.21	160	30x2.0	22x1.5	43.5	42.0	36	27	13.0	10.0	215
VKOR-22/18L	708.1074.755.21	160	30x2.0	26x1.5	44.0	42.0	36	32	13.0	13.0	228
VKOR-28/18L	708.1074.870.21	160	36x2.0	26x1.5	48.0	46.0	46	32	13.0	13.0	298
VKOR-28/22L	708.1074.900.21	160	36x2.0	30x2.0	48.0	46.0	46	36	17.0	17.0	309
VKOR-35/28L	708.1074.949.21	160	45x2.0	36x2.0	51.0	48.0	50	46	22.0	22.0	415

Baumaße sind Ungefährmaße bei angezogener Überwurfmutter.

Sizes are approximate dimensions at tightened nut.

Las medidas son aproximadas con la tuerca de unión apretada.

Dichtungsmaterial: FKM (andere Werkstoffe auf Anfrage)

Sealing material: FKM (other materials on request)

Material de junta tórica: FKM (otros materiales bajo demanda)

D1/D2=Rohr außen-Ø
 M1/M2=metrische Anschlußgewinde
 e1/e2=kleinste Innen-Ø

D1/D2=tube outside diameters
 M1/M2=metric connecting threads
 e1/e2=minimum inside diameters

D1/D2=Ø exteriores de los tubos
 M1/M2=rosca métrica conexión
 e1/e2=Ø interiores mínimos

Reduzierstutzen mit Dichtkegel und O-Ring

dichtkegelseitig vormontiert

Reducing connectors with taper and O-ring

pre-assembled on tapered nipple side

Cuerpos de reducción con junta cónica y junta tórica

premontado en lado de junta cónica

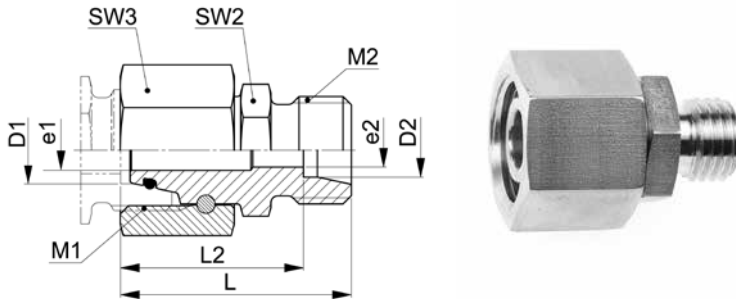

XGRKO-..L M

Type-D1 /D2	Mat.-Nr.	PN	M1	M2	L	L2	SW2	SW3	e1	e2	g/Stk
XGRKO-08/06L M	707.1871.140.20	315	14x1.5	12x1.5	30.5	23.5	12	17	4.0	4.0	30
XGRKO-10/06L M	707.1871.175.20	315	16x1.5	12x1.5	32.0	25.0	14	19	6.0	4.0	42
XGRKO-10/08L M	707.1871.190.20	315	16x1.5	14x1.5	32.0	25.0	14	19	6.0	6.0	40
XGRKO-12/06L M	707.1871.215.20	315	18x1.5	12x1.5	32.0	25.0	17	22	8.0	4.0	56
XGRKO-12/08L M	707.1871.225.20	315	18x1.5	14x1.5	32.0	25.0	17	22	8.0	6.0	56
XGRKO-12/10L M	707.1871.240.20	315	18x1.5	16x1.5	33.0	26.0	17	22	8.0	8.0	52
XGRKO-15/06L M	707.1871.391.20	315	22x1.5	12x1.5	35.5	28.5	22	27	10.0	4.0	88
XGRKO-15/08L M	707.1871.400.20	315	22x1.5	14x1.5	35.5	28.5	22	27	10.0	6.0	100
XGRKO-15/10L M	707.1871.410.20	315	22x1.5	16x1.5	36.0	29.0	22	27	10.0	8.0	96
XGRKO-15/12L M	707.1871.420.20	315	22x1.5	18x1.5	36.0	29.0	22	27	10.0	10.0	94
XGRKO-18/06L M	707.1871.563.20	315	26x1.5	12x1.5	35.0	28.0	24	32	13.0	4.0	112
XGRKO-18/08L M	707.1871.570.20	315	26x1.5	14x1.5	35.0	28.0	24	32	13.0	6.0	116
XGRKO-18/10L M	707.1871.575.20	315	26x1.5	16x1.5	36.0	29.0	24	32	13.0	8.0	128
XGRKO-18/12L M	707.1871.580.20	315	26x1.5	18x1.5	36.0	29.0	24	32	13.0	10.0	124
XGRKO-18/15L M	707.1871.610.20	315	26x1.5	22x1.5	37.0	30.0	24	32	13.0	12.0	126
XGRKO-22/06L M	707.1871.723.20	160	30x2.0	12x1.5	39.0	32.0	27	36	17.0	4.0	166
XGRKO-22/08L M	707.1871.724.20	160	30x2.0	14x1.5	39.0	32.0	27	36	17.0	6.0	164
XGRKO-22/10L M	707.1871.725.20	160	30x2.0	16x1.5	40.0	33.0	27	36	17.0	8.0	166
XGRKO-22/12L M	707.1871.730.20	160	30x2.0	18x1.5	40.0	33.0	27	36	17.0	10.0	166
XGRKO-22/15L M	707.1871.745.20	160	30x2.0	22x1.5	41.0	34.0	27	36	17.0	12.0	190
XGRKO-22/18L M	707.1871.755.20	160	30x2.0	26x1.5	41.0	33.5	27	36	17.0	15.0	180
XGRKO-28/06L M	707.1871.828.20	160	36x2.0	12x1.5	41.0	34.0	36	41	22.0	4.0	310
XGRKO-28/08L M	707.1871.829.20	160	36x2.0	14x1.5	41.0	34.0	36	41	22.0	6.0	306
XGRKO-28/10L M	707.1871.830.20	160	36x2.0	16x1.5	42.0	35.0	36	41	22.0	8.0	300
XGRKO-28/12L M	707.1871.835.20	160	36x2.0	18x1.5	42.0	35.0	36	41	22.0	10.0	300
XGRKO-28/15L M	707.1871.865.20	160	36x2.0	22x1.5	43.0	36.0	36	41	22.0	12.0	304
XGRKO-28/18L M	707.1871.870.20	160	36x2.0	26x1.5	43.0	35.5	36	41	22.0	15.0	247
XGRKO-28/22L M	707.1871.900.20	160	36x2.0	30x2.0	45.0	37.5	36	41	22.0	19.0	332

Fortsetzung auf nächster linker Seite

To be continued on next left page

Continuación próxima página izquierda

D1/D2=Rohr außen-Ø
M1/M2=metrische Anschlußgewinde
e1/e2=kleinste Innen-Ø

D1/D2=tube outside diameters
M1/M2=metric connecting threads
e1/e2=minimum inside diameters

D1/D2=Ø exteriores de los tubos
M1/M2=rosca métrica conexión
e1/e2=Ø interiores mínimo

Reduzierschraubungen mit Dichtkegel und O-Ring
Reducing fittings with taper and O-ring
Racores de reducción con junta cónica y junta tórica

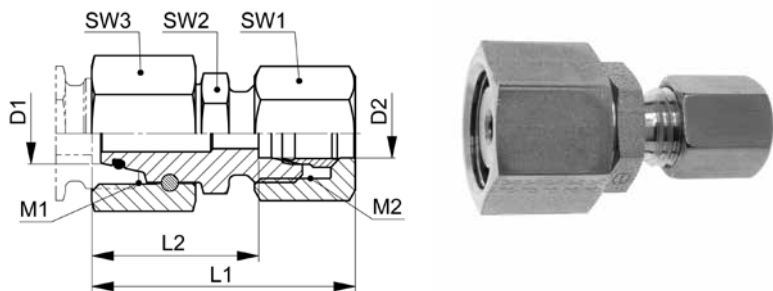

10

GRKO-..L

Type-D1 /D2	Mat.-Nr.	PN	M1	M2	L1	L2	SW1	SW2	SW3	g/Stk
GRKO-08/06L	708.1870.140.20	315	14x1.5	12x1.5	38.5	23.5	14	12	17	42
GRKO-10/06L	708.1870.175.20	315	16x1.5	12x1.5	40.0	25.0	14	14	19	54
GRKO-10/08L	708.1870.190.20	315	16x1.5	14x1.5	40.0	25.0	17	14	19	56
GRKO-12/06L	708.1870.215.20	315	18x1.5	12x1.5	40.0	25.0	14	17	22	68
GRKO-12/08L	708.1870.225.20	315	18x1.5	14x1.5	40.0	25.0	17	17	22	72
GRKO-12/10L	708.1870.240.20	315	18x1.5	16x1.5	41.0	26.0	19	17	22	74
GRKO-15/06L	708.1870.391.20	315	22x1.5	12x1.5	43.5	28.5	14	22	27	100
GRKO-15/08L	708.1870.400.20	315	22x1.5	14x1.5	43.5	28.5	17	22	27	118
GRKO-15/10L	708.1870.410.20	315	22x1.5	16x1.5	44.0	29.0	19	22	27	118
GRKO-15/12L	708.1870.420.20	315	22x1.5	18x1.5	44.0	29.0	22	22	27	122
GRKO-18/06L	708.1870.563.20	315	26x1.5	12x1.5	43.0	28.0	14	24	32	122
GRKO-18/08L	708.1870.570.20	315	26x1.5	14x1.5	43.0	28.0	17	24	32	132
GRKO-18/10L	708.1870.575.20	315	26x1.5	16x1.5	44.0	29.0	19	24	32	150
GRKO-18/12L	708.1870.580.20	315	26x1.5	18x1.5	44.0	29.0	22	24	32	152
GRKO-18/15L	708.1870.610.20	315	26x1.5	22x1.5	45.0	30.0	27	24	32	170
GRKO-22/06L	708.1870.723.20	160	30x2.0	12x1.5	47.0	32.0	14	27	36	178
GRKO-22/08L	708.1870.724.20	160	30x2.0	14x1.5	47.0	32.0	17	27	36	180
GRKO-22/10L	708.1870.725.20	160	30x2.0	16x1.5	48.0	33.0	19	27	36	186
GRKO-22/12L	708.1870.730.20	160	30x2.0	18x1.5	48.0	33.0	22	27	36	194
GRKO-22/15L	708.1870.745.20	160	30x2.0	22x1.5	49.0	34.0	27	27	36	236
GRKO-22/18L	708.1870.755.20	160	30x2.0	26x1.5	50.0	33.5	32	27	36	250
GRKO-28/06L	708.1870.828.20	160	36x2.0	12x1.5	49.0	34.0	14	36	41	322
GRKO-28/08L	708.1870.829.20	160	36x2.0	14x1.5	49.0	34.0	17	36	41	315
GRKO-28/10L	708.1870.830.20	160	36x2.0	16x1.5	50.0	35.0	19	36	41	320
GRKO-28/12L	708.1870.835.20	160	36x2.0	18x1.5	50.0	35.0	22	36	41	328
GRKO-28/15L	708.1870.865.20	160	36x2.0	22x1.5	51.0	36.0	27	36	41	350
GRKO-28/18L	708.1870.870.20	160	36x2.0	26x1.5	52.0	35.5	32	36	41	317
GRKO-28/22L	708.1870.900.20	160	36x2.0	30x2.0	54.0	37.5	36	36	41	420

Fortsetzung auf nächster rechter Seite

To be continued on next right page

Continuación próxima página derecha

D1/D2=Rohr außen-Ø
M1/M2=metrische Anschlußgewinde

D1/D2=tube outside diameters
M1/M2=metric connecting threads

D1/D2=Ø exteriores de los tubos
M1/M2=rosca métrica conexión

Reduzierstutzen mit Dichtkegel und O-Ring

dichtkegelseitig vormontiert

Reducing connectors with taper and O-ring

pre-assembled on tapered nipple side

Cuerpos de reducción con junta cónica y junta tórica

premontado en lado de junta cónica

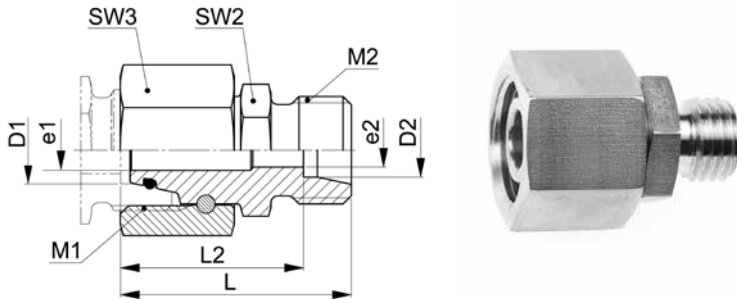

XGRKO-..L M

Type-D1 /D2	Mat.-Nr.	PN	M1	M2	L	L2	SW2	SW3	e1	e2	g/Stk
XGRKO-35/06L M	707.1871.951.20	160	45x2.0	12x1.5	44.0	37.0	46	50	28.0	4.0	349
XGRKO-35/08L M	707.1871.952.20	160	45x2.0	14x1.5	44.0	37.0	46	50	28.0	6.0	352
XGRKO-35/10L M	707.1871.953.20	160	45x2.0	16x1.5	45.0	38.0	46	50	28.0	8.0	355
XGRKO-35/12L M	707.1871.954.20	160	45x2.0	18x1.5	45.0	38.0	46	50	28.0	10.0	350
XGRKO-35/15L M	707.1871.946.20	160	45x2.0	22x1.5	46.0	39.0	46	50	28.0	12.0	358
XGRKO-35/18L M	707.1871.947.20	160	45x2.0	26x1.5	46.0	38.5	46	50	28.0	15.0	364
XGRKO-35/22L M	707.1871.948.20	160	45x2.0	30x2.0	48.0	40.5	46	50	28.0	19.0	362
XGRKO-35/28L M	707.1871.949.20	160	45x2.0	36x2.0	48.0	40.5	46	50	28.0	24.0	394
XGRKO-42/06L M	707.1871.986.20	160	52x2.0	12x1.5	47.5	40.5	50	60	34.0	4.0	536
XGRKO-42/08L M	707.1871.987.20	160	52x2.0	14x1.5	47.5	40.5	50	60	34.0	6.0	542
XGRKO-42/10L M	707.1871.988.20	160	52x2.0	16x1.5	48.5	41.5	50	60	34.0	8.0	548
XGRKO-42/12L M	707.1871.989.20	160	52x2.0	18x1.5	48.5	41.5	50	60	34.0	10.0	552
XGRKO-42/15L M	707.1871.991.20	160	52x2.0	22x1.5	49.5	42.5	50	60	34.0	12.0	554
XGRKO-42/18L M	707.1871.992.20	160	52x2.0	26x1.5	49.5	42.0	50	60	34.0	15.0	560
XGRKO-42/22L M	707.1871.993.20	160	52x2.0	30x2.0	51.5	44.0	50	60	34.0	19.0	528
XGRKO-42/28L M	707.1871.994.20	160	52x2.0	36x2.0	51.5	44.0	50	60	34.0	24.0	528
XGRKO-42/35L M	707.1871.996.20	160	52x2.0	45x2.0	53.5	43.0	50	60	34.0	30.0	592

Dichtungsmaterial: FKM (andere Werkstoffe auf Anfrage)

Sealing material: FKM (other materials on request)

Material de junta tórica: FKM (otros materiales bajo demanda)

ISO 8434-1-RDSW

D1/D2=Rohr außen-Ø
M1/M2=metrische Anschlußgewinde
e1/e2=kleinste Innen-Ø

D1/D2=tube outside diameters
M1/M2=metric connecting threads
e1/e2=minimum inside diameters

D1/D2=Ø exteriores de los tubos
M1/M2=rosca métrica conexión
e1/e2=Ø interiores mínimo

Reduzierschraubungen mit Dichtkegel und O-Ring
Reducing fittings with taper and O-ring
Racores de reducción con junta cónica y junta tórica

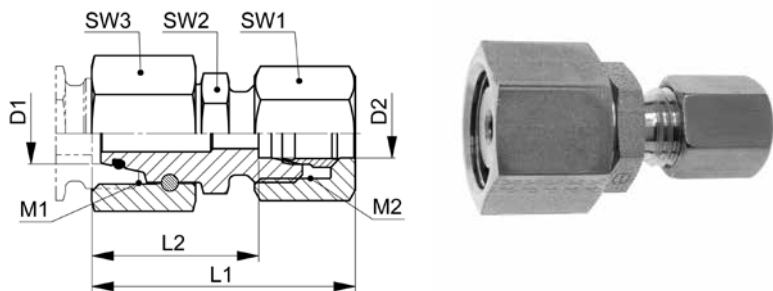

10

GRKO-..L

Type-D1 /D2	Mat.-Nr.	PN	M1	M2	L1	L2	SW1	SW2	SW3	g/Stk
GRKO-35/06L	708.1870.951.20	160	45x2.0	12x1.5	52.0	37.0	14	46	50	372
GRKO-35/08L	708.1870.952.20	160	45x2.0	14x1.5	52.0	37.0	17	46	50	388
GRKO-35/10L	708.1870.953.20	160	45x2.0	16x1.5	53.0	38.0	19	46	50	362
GRKO-35/12L	708.1870.954.20	160	45x2.0	18x1.5	53.0	38.0	22	46	50	378
GRKO-35/15L	708.1870.946.20	160	45x2.0	22x1.5	54.0	39.0	27	46	50	404
GRKO-35/18L	708.1870.947.20	160	45x2.0	26x1.5	55.0	38.5	32	46	50	432
GRKO-35/22L	708.1870.948.20	160	45x2.0	30x2.0	57.0	40.5	36	46	50	454
GRKO-35/28L	708.1870.949.20	160	45x2.0	36x2.0	57.0	40.5	41	46	50	504
GRKO-42/06L	708.1870.986.20	160	52x2.0	12x1.5	55.5	40.5	14	50	60	552
GRKO-42/08L	708.1870.987.20	160	52x2.0	14x1.5	55.5	40.5	17	50	60	558
GRKO-42/10L	708.1870.988.20	160	52x2.0	16x1.5	56.5	41.5	19	50	60	570
GRKO-42/12L	708.1870.989.20	160	52x2.0	18x1.5	56.5	41.5	22	50	60	582
GRKO-42/15L	708.1870.991.20	160	52x2.0	22x1.5	57.5	42.5	27	50	60	600
GRKO-42/18L	708.1870.992.20	160	52x2.0	26x1.5	58.5	42.0	32	50	60	628
GRKO-42/22L	708.1870.993.20	160	52x2.0	30x2.0	60.5	44.0	36	50	60	618
GRKO-42/28L	708.1870.994.20	160	52x2.0	36x2.0	60.5	44.0	41	50	60	636
GRKO-42/35L	708.1870.996.20	160	52x2.0	45x2.0	64.5	43.0	50	50	60	756

Baumaße sind Ungefährmaße bei angezogener Überwurfmutter.

Sizes are approximate dimensions at tightened nut.

Las medidas son aproximadas con la tuerca de unión apretada.

Dichtungsmaterial: FKM (andere Werkstoffe auf Anfrage)

Sealing material: FKM (other materials on request)

Material de junta tórica: FKM (otros materiales bajo demanda)

ISO 8434-1-RDSWC

Reduzierstutzen mit Dichtkegel und O-Ring

dichtkegelseitig vormontiert

Reducing connectors with taper and O-ring

pre-assembled on tapered nipple side

Cuerpos de reducción con junta cónica y junta tórica

premontado en lado de junta cónica

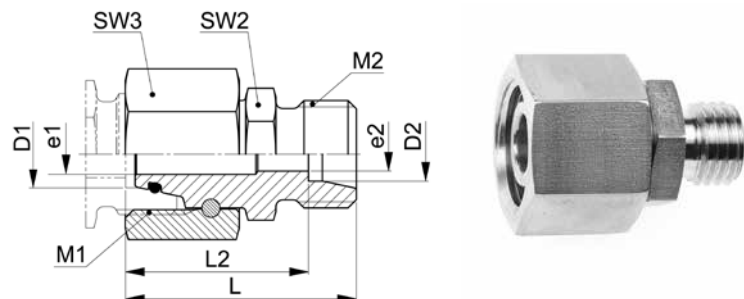

XGRKO-..S M

Type-D1 /D2	Mat.-Nr.	PN	M1	M2	L	L2	SW2	SW3	e1	e2	g/Stk
XGRKO-08/06S M	707.1871.140.30	630	16x1.5	14x1.5	34.0	27.0	14	19	4.0	4.0	46
XGRKO-10/06S M	707.1871.175.30	630	18x1.5	14x1.5	34.5	27.5	17	22	6.0	4.0	60
XGRKO-10/08S M	707.1871.190.30	630	18x1.5	16x1.5	34.5	27.5	17	22	6.0	5.0	62
XGRKO-12/06S M	707.1871.215.30	630	20x1.5	14x1.5	37.0	30.0	19	24	8.0	4.0	79
XGRKO-12/08S M	707.1871.225.30	630	20x1.5	16x1.5	37.0	30.0	19	24	8.0	5.0	80
XGRKO-12/10S M	707.1871.240.30	630	20x1.5	18x1.5	37.0	29.5	19	24	8.0	7.0	78
XGRKO-14/06S M	707.1871.296.30	630	22x1.5	14x1.5	38.5	31.5	22	27	9.0	4.0	114
XGRKO-14/08S M	707.1871.300.30	630	22x1.5	16x1.5	38.5	31.5	22	27	9.0	5.0	114
XGRKO-14/10S M	707.1871.320.30	630	22x1.5	18x1.5	38.5	31.0	22	27	9.0	7.0	110
XGRKO-14/12S M	707.1871.340.30	630	22x1.5	20x1.5	38.5	31.0	22	27	9.0	8.0	112
XGRKO-16/06S M	707.1871.466.30	400	24x1.5	14x1.5	39.0	32.0	22	30	11.0	4.0	110
XGRKO-16/08S M	707.1871.468.30	400	24x1.5	16x1.5	39.0	32.0	22	30	11.0	5.0	112
XGRKO-16/10S M	707.1871.470.30	400	24x1.5	18x1.5	39.0	31.5	22	30	11.0	7.0	121
XGRKO-16/12S M	707.1871.480.30	400	24x1.5	20x1.5	39.0	31.5	22	30	11.0	8.0	124
XGRKO-16/14S M	707.1871.500.30	400	24x1.5	22x1.5	41.0	33.0	22	30	11.0	10.0	128
XGRKO-20/06S M	707.1871.650.30	400	30x2.0	14x1.5	43.0	36.0	27	36	14.0	4.0	188
XGRKO-20/08S M	707.1871.655.30	400	30x2.0	16x1.5	43.0	36.0	27	36	14.0	5.0	176
XGRKO-20/10S M	707.1871.660.30	400	30x2.0	18x1.5	43.0	35.5	27	36	14.0	7.0	178
XGRKO-20/12S M	707.1871.665.30	400	30x2.0	20x1.5	43.0	35.5	27	36	14.0	8.0	200
XGRKO-20/14S M	707.1871.675.30	400	30x2.0	22x1.5	45.0	37.0	27	36	14.0	10.0	202
XGRKO-20/16S M	707.1871.685.30	400	30x2.0	24x1.5	45.0	36.5	27	36	14.0	12.0	294
XGRKO-25/06S M	707.1871.788.30	400	36x2.0	14x1.5	45.5	38.5	36	46	18.0	4.0	338
XGRKO-25/08S M	707.1871.787.30	400	36x2.0	16x1.5	45.5	38.5	36	46	18.0	5.0	340
XGRKO-25/10S M	707.1871.789.30	400	36x2.0	18x1.5	45.5	38.0	36	46	18.0	7.0	318
XGRKO-25/12S M	707.1871.791.30	400	36x2.0	20x1.5	45.5	38.0	36	46	18.0	10.0	320
XGRKO-25/14S M	707.1871.790.30	400	36x2.0	22x1.5	47.5	39.5	36	46	18.0	8.0	322
XGRKO-25/16S M	707.1871.800.30	400	36x2.0	24x1.5	47.5	39.0	36	46	18.0	12.0	324
XGRKO-25/20S M	707.1871.820.30	400	36x2.0	30x2.0	49.5	39.0	36	46	18.0	16.0	346

Fortsetzung auf nächster linker Seite

To be continued on next left page

Continuación próxima página izquierda

D1/D2=Rohr außen-Ø
M1/M2=metrische Anschlußgewinde
e1/e2=kleinste Innen-Ø

D1/D2=tube outside diameters
M1/M2=metric connecting threads
e1/e2=minimum inside diameters

D1/D2=Ø exteriores de los tubos
M1/M2=rosca métrica conexión
e1/e2=Ø interiores mínimo

Reduzierschraubungen mit Dichtkegel und O-Ring
Reducing fittings with taper and O-ring
Racores de reducción con junta cónica y junta tórica

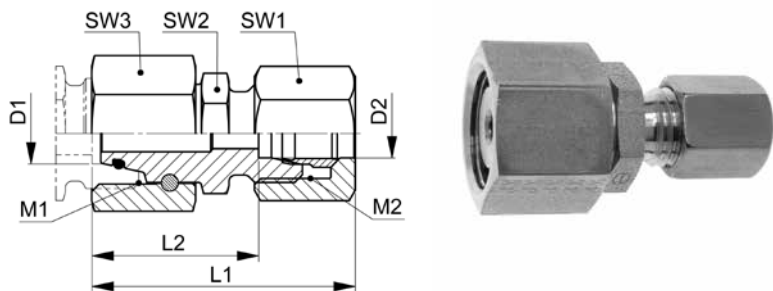

10

GRKO-..S

Type-D1 /D2	Mat.-Nr.	PN	M1	M2	L1	L2	SW1	SW2	SW3	g/Stk
GRKO-08/06S	708.1870.140.30	630	16x1.5	14x1.5	42.0	27.0	17	14	19	64
GRKO-10/06S	708.1870.175.30	630	18x1.5	14x1.5	43.5	27.5	17	17	22	78
GRKO-10/08S	708.1870.190.30	630	18x1.5	16x1.5	42.5	27.5	19	17	22	82
GRKO-12/06S	708.1870.215.30	630	20x1.5	14x1.5	45.0	30.0	17	19	24	98
GRKO-12/08S	708.1870.225.30	630	20x1.5	16x1.5	45.0	30.0	19	19	24	100
GRKO-12/10S	708.1870.240.30	630	20x1.5	18x1.5	46.0	29.5	22	19	24	112
GRKO-14/06S	708.1870.296.30	630	22x1.5	14x1.5	46.5	31.5	17	22	27	132
GRKO-14/08S	708.1870.300.30	630	22x1.5	16x1.5	46.5	31.5	19	22	27	136
GRKO-14/10S	708.1870.320.30	630	22x1.5	18x1.5	47.5	31.0	22	22	27	146
GRKO-14/12S	708.1870.340.30	630	22x1.5	20x1.5	47.5	31.0	24	22	27	148
GRKO-16/06S	708.1870.466.30	400	24x1.5	14x1.5	47.0	32.0	17	22	30	128
GRKO-16/08S	708.1870.468.30	400	24x1.5	16x1.5	47.0	32.0	19	22	30	134
GRKO-16/10S	708.1870.470.30	400	24x1.5	18x1.5	48.0	31.5	22	22	30	156
GRKO-16/12S	708.1870.480.30	400	24x1.5	20x1.5	48.0	31.5	24	22	30	160
GRKO-16/14S	708.1870.500.30	400	24x1.5	22x1.5	51.0	33.0	27	22	30	184
GRKO-20/06S	708.1870.650.30	400	30x2.0	14x1.5	51.0	36.0	17	27	36	206
GRKO-20/08S	708.1870.655.30	400	30x2.0	16x1.5	51.0	36.0	19	27	36	198
GRKO-20/10S	708.1870.660.30	400	30x2.0	18x1.5	52.0	35.5	22	27	36	210
GRKO-20/12S	708.1870.665.30	400	30x2.0	20x1.5	52.0	35.5	24	27	36	238
GRKO-20/14S	708.1870.675.30	400	30x2.0	22x1.5	55.0	37.0	27	27	36	258
GRKO-20/16S	708.1870.685.30	400	30x2.0	24x1.5	55.0	36.5	30	27	36	264
GRKO-25/06S	708.1870.788.30	400	36x2.0	14x1.5	53.5	38.5	17	36	46	356
GRKO-25/08S	708.1870.787.30	400	36x2.0	16x1.5	53.5	38.5	19	36	46	362
GRKO-25/10S	708.1870.789.30	400	36x2.0	18x1.5	54.5	38.0	22	36	46	352
GRKO-25/12S	708.1870.791.30	400	36x2.0	20x1.5	54.5	38.0	24	36	46	356
GRKO-25/14S	708.1870.790.30	400	36x2.0	22x1.5	57.5	39.5	27	36	46	374
GRKO-25/16S	708.1870.800.30	400	36x2.0	24x1.5	57.5	39.0	30	36	46	394
GRKO-25/20S	708.1870.820.30	400	36x2.0	30x2.0	60.5	39.0	36	36	46	458

Fortsetzung auf nächster rechter Seite

To be continued on next right page

Continuación próxima página derecha

D1/D2=Rohr außen-Ø
M1/M2=metrische Anschlußgewinde

D1/D2=tube outside diameters
M1/M2=metric connecting threads

D1/D2=Ø exteriores de los tubos
M1/M2=rosca métrica conexión

Reduzierstutzen mit Dichtkegel und O-Ring

dichtkegelseitig vormontiert

Reducing connectors with taper and O-ring

pre-assembled on tapered nipple side

Cuerpos de reducción con junta cónica y junta tórica

premontado en lado de junta cónica

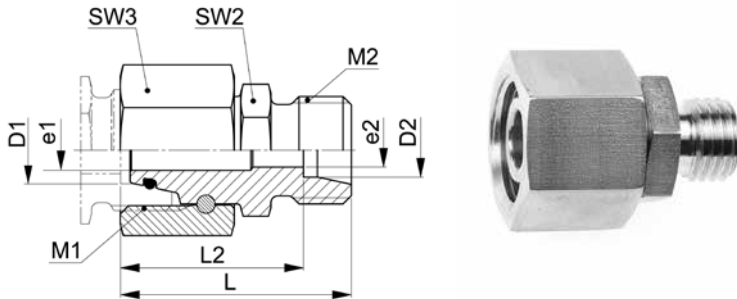

XGRKO-..S M

Type-D1 /D2	Mat.-Nr.	PN	M1	M2	L	L2	SW2	SW3	e1	e2	g/Stk
XGRKO-30/06S M	707.1871.937.30	400	42x2.0	14x1.5	51.0	44.0	41	50	23.0	5.0	378
XGRKO-30/08S M	707.1871.936.30	400	42x2.0	16x1.5	51.0	44.0	41	50	23.0	4.0	384
XGRKO-30/10S M	707.1871.939.30	400	42x2.0	18x1.5	51.0	43.5	41	50	23.0	7.0	390
XGRKO-30/12S M	707.1871.940.30	400	42x2.0	20x1.5	51.0	43.5	41	50	23.0	8.0	396
XGRKO-30/14S M	707.1871.941.30	400	42x2.0	22x1.5	53.0	45.0	41	50	23.0	10.0	424
XGRKO-30/16S M	707.1871.942.30	400	42x2.0	24x1.5	53.0	44.5	41	50	23.0	12.0	398
XGRKO-30/20S M	707.1871.943.30	400	42x2.0	30x2.0	55.0	44.5	41	50	23.0	16.0	418
XGRKO-30/25S M	707.1871.945.30	400	42x2.0	36x2.0	57.0	45.0	41	50	23.0	20.0	446
XGRKO-38/06S M	707.1871.965.30	315	52x2.0	14x1.5	54.5	47.5	50	60	30.0	4.0	550
XGRKO-38/08S M	707.1871.966.30	315	52x2.0	16x1.5	54.5	47.5	50	60	30.0	5.0	552
XGRKO-38/10S M	707.1871.967.30	315	52x2.0	18x1.5	54.5	47.0	50	60	30.0	7.0	555
XGRKO-38/12S M	707.1871.968.30	315	52x2.0	20x1.5	54.5	47.0	50	60	30.0	8.0	556
XGRKO-38/14S M	707.1871.969.30	315	52x2.0	22x1.5	56.5	48.5	50	60	30.0	10.0	600
XGRKO-38/16S M	707.1871.970.30	315	52x2.0	24x1.5	56.5	48.0	50	60	30.0	12.0	602
XGRKO-38/20S M	707.1871.971.30	315	52x2.0	30x2.0	58.5	48.0	50	60	30.0	16.0	570
XGRKO-38/25S M	707.1871.972.30	315	52x2.0	36x2.0	60.5	48.5	50	60	30.0	20.0	592
XGRKO-38/30S M	707.1871.975.30	315	52x2.0	42x2.0	62.5	49.0	50	60	30.0	25.0	662

Dichtungsmaterial: FKM (andere Werkstoffe auf Anfrage)

Sealing material: FKM (other materials on request)

Material de junta tórica: FKM (otros materiales bajo demanda)

ISO 8434-1-RDSW

D1/D2=Rohr außen-Ø
M1/M2=metrische Anschlußgewinde
e1/e2=kleinste Innen-Ø

D1/D2=tube outside diameters
M1/M2=metric connecting threads
e1/e2=minimum inside diameters

D1/D2=Ø exteriores de los tubos
M1/M2=rosca métrica conexión
e1/e2=Ø interiores mínimo

Reduzierschraubungen mit Dichtkegel und O-Ring
Reducing fittings with taper and O-ring
Racores de reducción con junta cónica y junta tórica

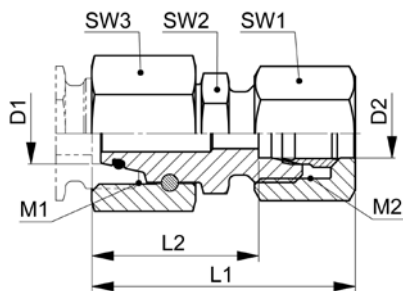

10

GRKO-..S

Type-D1 /D2	Mat.-Nr.	PN	M1	M2	L1	L2	SW1	SW2	SW3	g/Stk
GRKO-30/06S	708.1870.937.30	400	42x2.0	14x1.5	59.0	44.0	17	41	50	412
GRKO-30/08S	708.1870.936.30	400	42x2.0	16x1.5	59.0	44.0	19	41	50	416
GRKO-30/10S	708.1870.939.30	400	42x2.0	18x1.5	60.0	43.5	22	41	50	424
GRKO-30/12S	708.1870.940.30	400	42x2.0	20x1.5	60.0	43.5	24	41	50	432
GRKO-30/14S	708.1870.941.30	400	42x2.0	22x1.5	63.0	45.0	27	41	50	480
GRKO-30/16S	708.1870.942.30	400	42x2.0	24x1.5	63.0	44.5	30	41	50	468
GRKO-30/20S	708.1870.943.30	400	42x2.0	30x2.0	66.0	44.5	36	41	50	528
GRKO-30/25S	708.1870.945.30	400	42x2.0	36x2.0	69.0	45.0	46	41	50	672
GRKO-38/06S	708.1870.965.30	315	52x2.0	14x1.5	62.0	47.5	17	50	60	574
GRKO-38/08S	708.1870.966.30	315	52x2.0	16x1.5	62.0	47.5	19	50	60	578
GRKO-38/10S	708.1870.967.30	315	52x2.0	18x1.5	63.0	47.0	22	50	60	632
GRKO-38/12S	708.1870.968.30	315	52x2.0	20x1.5	63.0	47.0	24	50	60	638
GRKO-38/14S	708.1870.969.30	315	52x2.0	22x1.5	66.0	48.5	27	50	60	652
GRKO-38/16S	708.1870.970.30	315	52x2.0	24x1.5	66.0	48.0	30	50	60	672
GRKO-38/20S	708.1870.971.30	315	52x2.0	30x2.0	69.0	48.0	36	50	60	682
GRKO-38/25S	708.1870.972.30	315	52x2.0	36x2.0	72.0	48.5	46	50	60	818
GRKO-38/30S	708.1870.975.30	315	52x2.0	42x2.0	75.0	49.0	50	50	60	914

Baumaße sind Ungefährmaße bei angezogener Überwurfmutter.

Sizes are approximate dimensions at tightened nut.

Las medidas son aproximadas con la tuerca de unión apretada.

Dichtungsmaterial: FKM (andere Werkstoffe auf Anfrage)

Sealing material: FKM (other materials on request)

Material de junta tórica: FKM (otros materiales bajo demanda)

ISO 8434-1-RDSWC

Gerade Reduzierstutzen

Reducing connectors

Cuerpos de reducción rectos

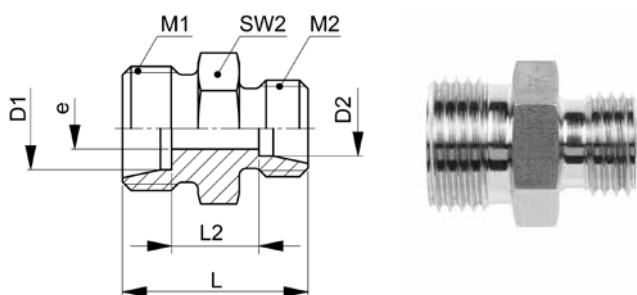

XGR-.L

Type-D1 / D2	Mat.-Nr.	PN	M1	M2	L	L2	SW2	e	g/Stk
XGR-06/04LL	706.1024.100.10	100	10x1.0	8x1.0	20.0	10.0	11	3.0	8
XGR-08/06LL	706.1024.140.10	100	12x1.0	10x1.0	22.0	11.0	12	4.0	12
XGR-08/06L	706.1024.140.20	500	14x1.5	12x1.5	25.0	11.0	14	4.0	19
XGR-10/06L	706.1024.175.20	500	16x1.5	12x1.5	26.0	12.0	17	4.0	25
XGR-10/08L	706.1024.190.20	500	16x1.5	14x1.5	26.0	12.0	17	6.0	25
XGR-12/06L	706.1024.215.20	400	18x1.5	12x1.5	27.0	13.0	19	4.0	32
XGR-12/08L	706.1024.225.20	400	18x1.5	14x1.5	27.0	13.0	19	6.0	32
XGR-12/10L	706.1024.240.20	400	18x1.5	16x1.5	28.0	14.0	19	8.0	33
XGR-15/06L	706.1024.391.20	400	22x1.5	12x1.5	28.0	14.0	24	4.0	51
XGR-15/08L	706.1024.400.20	400	22x1.5	14x1.5	28.0	14.0	24	6.0	51
XGR-15/10L	706.1024.410.20	400	22x1.5	16x1.5	29.0	15.0	24	8.0	51
XGR-15/12L	706.1024.420.20	400	22x1.5	18x1.5	29.0	15.0	24	10.0	50
XGR-18/08L	706.1024.570.20	400	26x1.5	14x1.5	29.0	14.0	27	6.0	70
XGR-18/10L	706.1024.575.20	400	26x1.5	16x1.5	30.0	15.0	27	8.0	70
XGR-18/12L	706.1024.580.20	400	26x1.5	18x1.5	30.0	15.0	27	10.0	70
XGR-18/15L	706.1024.610.20	400	26x1.5	22x1.5	31.0	16.0	27	12.0	74
XGR-22/08L	706.1024.724.20	250	30x2.0	14x1.5	31.0	16.5	32	6.0	100
XGR-22/10L	706.1024.725.20	250	30x2.0	16x1.5	32.0	17.0	32	8.0	101
XGR-22/12L	706.1024.730.20	250	30x2.0	18x1.5	32.0	17.0	32	10.0	100
XGR-22/15L	706.1024.745.20	250	30x2.0	22x1.5	33.0	18.0	32	12.0	104
XGR-22/18L	706.1024.755.20	250	30x2.0	26x1.5	33.0	18.0	32	15.0	104
XGR-28/10L	706.1024.830.20	250	36x2.0	16x1.5	33.0	18.0	41	8.0	163
XGR-28/12L	706.1024.835.20	250	36x2.0	18x1.5	33.0	18.0	41	10.0	161
XGR-28/15L	706.1024.865.20	250	36x2.0	22x1.5	34.0	19.0	41	12.0	165
XGR-28/18L	706.1024.870.20	250	36x2.0	26x1.5	34.0	19.0	41	15.0	164
XGR-28/22L	706.1024.900.20	250	36x2.0	30x2.0	36.0	21.0	41	19.0	161
XGR-35/15L	706.1024.946.20	250	45x2.0	22x1.5	37.0	19.0	46	12.0	243
XGR-35/18L	706.1024.947.20	250	45x2.0	26x1.5	37.0	19.0	46	15.0	242
XGR-35/22L	706.1024.948.20	250	45x2.0	30x2.0	39.0	21.0	46	19.0	239
XGR-35/28L	706.1024.949.20	250	45x2.0	36x2.0	39.0	21.0	46	24.0	230
XGR-42/15L	706.1024.991.20	250	52x2.0	22x1.5	39.0	21.0	55	12.0	363
XGR-42/18L	706.1024.992.20	250	52x2.0	26x1.5	39.0	20.0	55	15.0	362
XGR-42/22L	706.1024.993.20	250	52x2.0	30x2.0	41.0	22.0	55	19.0	358
XGR-42/28L	706.1024.994.20	250	52x2.0	36x2.0	41.0	22.0	55	24.0	346
XGR-42/35L	706.1024.996.20	250	52x2.0	45x2.0	43.0	21.0	55	30.0	347

D1/D2=Rohr außen-Ø
 M1/M2=metrische Anschlußgewinde
 e=kleinster Innen-Ø

D1/D2=tube outside diameter
 M1/M2=metric connecting threads
 e=minimum inside diameter

D1/D2=Ø exterior del tubo
 M1/M2=rosca métrica conexión
 e=Ø interior mínimo

Gerade Reduzierschraubungen

Straight reducing fittings

Racores de reducción rectos

10

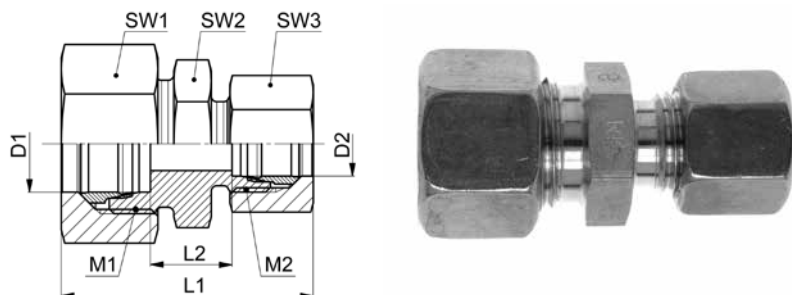

GR..L

Type-D1 /D2	Mat.-Nr.	PN	M1	M2	L1	L2	SW1	SW2	SW3	g/Stk
GR-06/04LL	708.1024.110.10	100	10x1.0	8x1.0	32.0	10.0	12	11	10	20
GR-08/06LL	708.1024.140.10	100	12x1.0	10x1.0	34.0	11.0	14	12	12	26
GR-08/06L	708.1024.140.20	500	14x1.5	12x1.5	41.0	11.0	17	14	14	51
GR-10/06L	708.1024.175.20	500	16x1.5	12x1.5	42.0	12.0	19	17	14	58
GR-10/08L	708.1024.190.20	500	16x1.5	14x1.5	42.0	12.0	19	17	17	58
GR-12/06L	708.1024.215.20	400	18x1.5	12x1.5	43.0	13.0	22	19	14	63
GR-12/08L	708.1024.225.20	400	18x1.5	14x1.5	43.0	13.0	22	19	17	70
GR-12/10L	708.1024.240.20	400	18x1.5	16x1.5	44.0	14.0	22	19	19	80
GR-15/06L	708.1024.391.20	400	22x1.5	12x1.5	44.0	14.0	27	24	14	100
GR-15/08L	708.1024.400.20	400	22x1.5	14x1.5	44.0	14.0	27	24	17	105
GR-15/10L	708.1024.410.20	400	22x1.5	16x1.5	45.0	15.0	27	24	19	110
GR-15/12L	708.1024.420.20	400	22x1.5	18x1.5	45.0	15.0	27	24	22	132
GR-18/08L	708.1024.570.20	400	26x1.5	14x1.5	46.0	14.0	32	27	17	115
GR-18/10L	708.1024.575.20	400	26x1.5	16x1.5	47.0	15.0	32	27	19	145
GR-18/12L	708.1024.580.20	400	26x1.5	18x1.5	47.0	15.0	32	27	22	175
GR-18/15L	708.1024.610.20	400	26x1.5	22x1.5	48.0	16.0	32	27	27	175
GR-22/08L	708.1024.724.20	250	30x2.0	14x1.5	48.0	16.5	36	32	17	207
GR-22/10L	708.1024.725.20	250	30x2.0	16x1.5	49.0	17.0	36	32	19	198
GR-22/12L	708.1024.730.20	250	30x2.0	18x1.5	49.0	17.0	36	32	22	200
GR-22/15L	708.1024.745.20	250	30x2.0	22x1.5	50.0	18.0	36	32	27	220
GR-22/18L	708.1024.755.20	250	30x2.0	26x1.5	51.0	18.0	36	32	32	274
GR-28/10L	708.1024.830.20	250	36x2.0	16x1.5	50.0	18.0	41	41	19	250
GR-28/12L	708.1024.835.20	250	36x2.0	18x1.5	50.0	18.0	41	41	22	270
GR-28/15L	708.1024.865.20	250	36x2.0	22x1.5	51.0	19.0	41	41	27	296
GR-28/18L	708.1024.870.20	250	36x2.0	26x1.5	52.0	19.0	41	41	32	307
GR-28/22L	708.1024.900.20	250	36x2.0	30x2.0	54.0	21.0	41	41	36	309
GR-35/15L	708.1024.946.20	250	45x2.0	22x1.5	56.0	19.0	50	46	27	390
GR-35/18L	708.1024.947.20	250	45x2.0	26x1.5	57.0	19.0	50	46	32	410
GR-35/22L	708.1024.948.20	250	45x2.0	30x2.0	59.0	21.0	50	46	36	434
GR-35/28L	708.1024.949.20	250	45x2.0	36x2.0	59.0	21.0	50	46	41	455
GR-42/15L	708.1024.991.20	250	52x2.0	22x1.5	59.0	21.0	60	55	27	550
GR-42/18L	708.1024.992.20	250	52x2.0	26x1.5	60.0	20.0	60	55	32	590
GR-42/22L	708.1024.993.20	250	52x2.0	30x2.0	62.0	22.0	60	55	36	610
GR-42/28L	708.1024.994.20	250	52x2.0	36x2.0	62.0	22.0	60	55	41	650
GR-42/35L	708.1024.996.20	250	52x2.0	45x2.0	66.0	21.0	60	55	50	786

Baumaße sind Ungefährmaße bei angezogener Überwurfmutter.

Sizes are approximate dimensions at tightened nut.

Las medidas son aproximadas con la tuerca de unión apretada.

D1/D2=Rohr außen-Ø
M1/M2=metrische Anschlußgewinde

D1/D2=tube outside diameter
M1/M2=metric connecting threads

D1/D2=Ø exterior del tubo
M1/M2=rosca métrica conexión

Gerade Reduzierstutzen

Reducing connectors

Cuerpos de reducción rectos

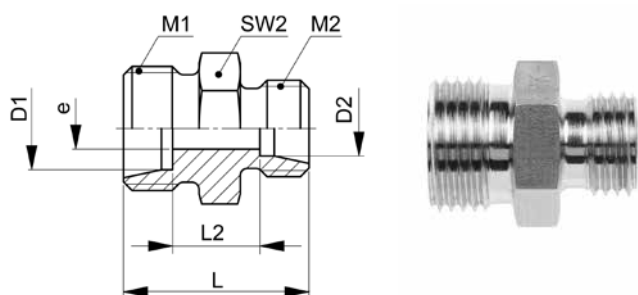

XGR-.S

Type-D1 / D2	Mat.-Nr.	PN	M1	M2	L	L2	SW2	e	g/Stk
XGR-08/06S	706.1024.140.30	800	16x1.5	14x1.5	32.0	18.0	17	4.0	39
XGR-10/06S	706.1024.175.30	800	18x1.5	14x1.5	32.0	17.5	19	4.0	46
XGR-10/08S	706.1024.190.30	800	18x1.5	16x1.5	32.0	17.5	19	5.0	48
XGR-12/06S	706.1024.215.30	630	20x1.5	14x1.5	34.0	19.5	22	4.0	62
XGR-12/08S	706.1024.225.30	630	20x1.5	16x1.5	34.0	19.5	22	5.0	64
XGR-12/10S	706.1024.240.30	630	20x1.5	18x1.5	34.0	19.0	22	7.0	64
XGR-14/06S	706.1024.296.30	630	22x1.5	14x1.5	36.0	20.5	24	4.0	77
XGR-14/08S	706.1024.300.30	630	22x1.5	16x1.5	36.0	20.5	24	5.0	79
XGR-14/10S	706.1024.320.30	630	22x1.5	18x1.5	36.0	20.0	24	7.0	79
XGR-14/12S	706.1024.340.30	630	22x1.5	20x1.5	36.0	20.0	24	8.0	80
XGR-16/06S	706.1024.466.30	630	24x1.5	14x1.5	36.0	20.0	27	4.0	92
XGR-16/08S	706.1024.468.30	630	24x1.5	16x1.5	36.0	20.0	27	5.0	94
XGR-16/10S	706.1024.470.30	630	24x1.5	18x1.5	36.0	19.5	27	7.0	93
XGR-16/12S	706.1024.480.30	630	24x1.5	20x1.5	36.0	19.5	27	8.0	95
XGR-16/14S	706.1024.500.30	630	24x1.5	22x1.5	38.0	21.0	27	10.0	98
XGR-20/06S	706.1024.650.30	420	30x2.0	14x1.5	40.0	22.0	32	4.0	149
XGR-20/08S	706.1024.655.30	420	30x2.0	16x1.5	40.0	22.0	32	5.0	150
XGR-20/10S	706.1024.660.30	420	30x2.0	18x1.5	40.0	21.5	32	7.0	148
XGR-20/12S	706.1024.665.30	420	30x2.0	20x1.5	40.0	21.5	32	8.0	149
XGR-20/14S	706.1024.675.30	420	30x2.0	22x1.5	42.0	23.0	32	10.0	154
XGR-20/16S	706.1024.685.30	420	30x2.0	24x1.5	42.0	22.5	32	12.0	152
XGR-25/06S	706.1024.788.30	420	36x2.0	14x1.5	44.0	24.5	41	5.0	248
XGR-25/08S	706.1024.787.30	420	36x2.0	16x1.5	44.0	24.5	41	4.0	249
XGR-25/10S	706.1024.789.30	420	36x2.0	18x1.5	44.0	24.0	41	7.0	259
XGR-25/12S	706.1024.791.30	420	36x2.0	20x1.5	46.0	25.5	41	10.0	263
XGR-25/14S	706.1024.790.30	420	36x2.0	22x1.5	44.0	24.0	41	8.0	260
XGR-25/16S	706.1024.800.30	420	36x2.0	24x1.5	46.0	25.0	41	12.0	260
XGR-25/20S	706.1024.820.30	420	36x2.0	30x2.0	48.0	25.0	41	16.0	265
XGR-30/10S	706.1024.939.30	420	42x2.0	18x1.5	46.0	24.5	46	7.0	344
XGR-30/12S	706.1024.940.30	420	42x2.0	20x1.5	46.0	24.5	46	8.0	345
XGR-30/14S	706.1024.941.30	420	42x2.0	22x1.5	46.0	24.0	46	10.0	343
XGR-30/16S	706.1024.942.30	420	42x2.0	24x1.5	48.0	25.5	46	12.0	345
XGR-30/20S	706.1024.943.30	420	42x2.0	30x2.0	50.0	25.5	46	16.0	349
XGR-30/25S	706.1024.945.30	420	42x2.0	36x2.0	52.0	26.0	46	20.0	358

Fortsetzung auf nächster linker Seite

To be continued on next left page

Continuación próxima página izquierda

D1/D2=Rohr außen-Ø
 M1/M2=metrische Anschlußgewinde
 e=kleinster Innen-Ø

D1/D2=tube outside diameter
 M1/M2=metric connecting threads
 e=minimum inside diameter

D1/D2=Ø exterior del tubo
 M1/M2=rosca métrica conexión
 e=Ø interior mínimo

Gerade Reduzierschraubungen

Straight reducing fittings

Racores de reducción rectos

10

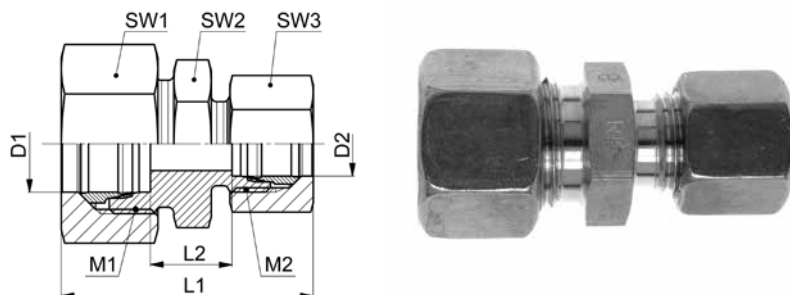

GR..S

Type-D1 /D2	Mat.-Nr.	PN	M1	M2	L1	L2	SW1	SW2	SW3	g/Stk
GR-08/06S	708.1024.140.30	800	16x1.5	14x1.5	48.0	18.0	19	17	17	85
GR-10/06S	708.1024.175.30	800	18x1.5	14x1.5	49.0	17.5	22	19	17	95
GR-10/08S	708.1024.190.30	800	18x1.5	16x1.5	49.0	17.5	22	19	19	100
GR-12/06S	708.1024.215.30	630	20x1.5	14x1.5	51.0	19.5	24	22	17	105
GR-12/08S	708.1024.225.30	630	20x1.5	16x1.5	51.0	19.5	24	22	19	115
GR-12/10S	708.1024.240.30	630	20x1.5	18x1.5	52.0	19.0	24	22	22	125
GR-14/06S	708.1024.296.30	630	22x1.5	14x1.5	54.0	21.0	27	24	17	125
GR-14/08S	708.1024.300.30	630	22x1.5	16x1.5	54.0	21.0	27	24	19	140
GR-14/10S	708.1024.320.30	630	22x1.5	18x1.5	55.0	20.5	27	24	22	125
GR-14/12S	708.1024.340.30	630	22x1.5	20x1.5	55.0	20.5	27	24	24	182
GR-16/06S	708.1024.466.30	630	24x1.5	14x1.5	54.0	20.5	30	27	17	170
GR-16/08S	708.1024.468.30	630	24x1.5	16x1.5	54.0	20.5	30	27	19	180
GR-16/10S	708.1024.470.30	630	24x1.5	18x1.5	55.0	20.0	30	27	22	185
GR-16/12S	708.1024.480.30	630	24x1.5	20x1.5	55.0	20.0	30	27	24	190
GR-16/14S	708.1024.500.30	630	24x1.5	22x1.5	58.0	21.5	30	27	27	215
GR-20/06S	708.1024.650.30	420	30x2.0	14x1.5	59.0	22.5	36	32	17	230
GR-20/08S	708.1024.655.30	420	30x2.0	16x1.5	59.0	22.5	36	32	19	250
GR-20/10S	708.1024.660.30	420	30x2.0	18x1.5	60.0	22.0	36	32	22	270
GR-20/12S	708.1024.665.30	420	30x2.0	20x1.5	60.0	22.0	36	32	24	312
GR-20/14S	708.1024.675.30	420	30x2.0	22x1.5	63.0	23.5	36	32	27	300
GR-20/16S	708.1024.685.30	420	30x2.0	24x1.5	63.0	23.0	36	32	30	315
GR-25/06S	708.1024.788.30	420	36x2.0	14x1.5	64.0	25.0	46	41	17	491
GR-25/08S	708.1024.787.30	420	36x2.0	16x1.5	64.0	25.0	46	41	19	495
GR-25/10S	708.1024.789.30	420	36x2.0	18x1.5	65.0	24.5	46	41	22	480
GR-25/12S	708.1024.791.30	420	36x2.0	20x1.5	65.0	26.0	46	41	24	500
GR-25/14S	708.1024.790.30	420	36x2.0	22x1.5	68.0	24.5	46	41	27	545
GR-25/16S	708.1024.800.30	420	36x2.0	24x1.5	68.0	25.5	46	41	30	552
GR-25/20S	708.1024.820.30	420	36x2.0	30x2.0	71.0	25.5	46	41	36	564
GR-30/10S	708.1024.939.30	420	42x2.0	18x1.5	68.0	25.0	50	46	22	548
GR-30/12S	708.1024.940.30	420	42x2.0	20x1.5	68.0	25.0	50	46	24	643
GR-30/14S	708.1024.941.30	420	42x2.0	22x1.5	69.0	24.5	50	46	27	580
GR-30/16S	708.1024.942.30	420	42x2.0	24x1.5	71.0	26.0	50	46	30	632
GR-30/20S	708.1024.943.30	420	42x2.0	30x2.0	74.0	26.0	50	46	36	778
GR-30/25S	708.1024.945.30	420	42x2.0	36x2.0	77.0	26.5	50	46	46	802

Fortsetzung auf nächster rechter Seite

To be continued on next right page

Continuación próxima página derecha

D1/D2=Rohr außen-Ø
M1/M2=metrische Anschlußgewinde

D1/D2=tube outside diameter
M1/M2=metric connecting threads

D1/D2=Ø exterior del tubo
M1/M2=rosca métrica conexión

Gerade Reduzierstutzen

Reducing connectors

Cuerpos de reducción rectos

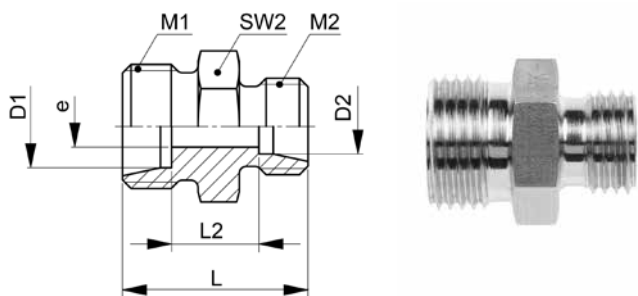

XGR-..S

Type -D1 /D2	Mat.-Nr.	PN	M1	M2	L	L2	SW2	e	g/Stk
XGR-38/10S	706.1024.967.30	420	52x2.0	18x1.5	51.0	27.0	55	7.0	571
XGR-38/12S	706.1024.968.30	420	52x2.0	20x1.5	51.0	27.0	55	8.0	571
XGR-38/14S	706.1024.969.30	420	52x2.0	22x1.5	53.0	28.5	55	10.0	573
XGR-38/16S	706.1024.970.30	420	52x2.0	24x1.5	53.0	28.0	55	12.0	570
XGR-38/20S	706.1024.971.30	420	52x2.0	30x2.0	55.0	28.0	55	16.0	573
XGR-38/25S	706.1024.972.30	420	52x2.0	36x2.0	57.0	28.5	55	20.0	579
XGR-38/30S	706.1024.975.30	420	52x2.0	42x2.0	59.0	29.0	55	25.0	580

D1/D2=Rohr außen-Ø
M1/M2=metrische Anschlußgewinde
e=kleinster Innen-Ø

D1/D2=tube outside diameter
M1/M2=metric connecting threads
e=minimum inside diameter

D1/D2=Ø exterior del tubo
M1/M2=rosca métrica conexión
e=Ø interior mínimo

Gerade Reduzierschraubungen
Straight reducing fittings
Racores de reducción rectos

10

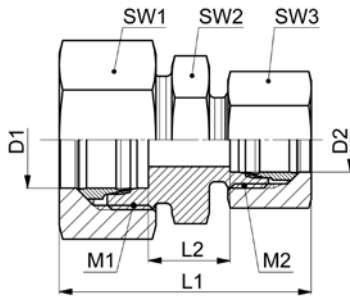

GR..S

Type-D1 /D2	Mat.-Nr.	PN	M1	M2	L1	L2	SW1	SW2	SW3	g/Stk
GR-38/10S	708.1024.967.30	420	52x2.0	18x1.5	75.0	27.5	60	55	22	870
GR-38/12S	708.1024.968.30	420	52x2.0	20x1.5	75.0	27.5	60	55	24	885
GR-38/14S	708.1024.969.30	420	52x2.0	22x1.5	78.0	29.0	60	55	27	910
GR-38/16S	708.1024.970.30	420	52x2.0	24x1.5	78.0	28.5	60	55	30	925
GR-38/20S	708.1024.971.30	420	52x2.0	30x2.0	81.0	28.5	60	55	36	975
GR-38/25S	708.1024.972.30	420	52x2.0	36x2.0	84.0	29.0	60	55	46	1090
GR-38/30S	708.1024.975.30	420	52x2.0	42x2.0	87.0	29.5	60	55	50	1216

Baumaße sind Ungefährmaße bei angezogener Überwurfmutter.

Sizes are approximate dimensions at tightened nut.

Las medidas son aproximadas con la tuerca de unión apretada.

D1/D2=Rohraußen-Ø
 M1/M2=metrische Anschlußgewinde

D1/D2=tube outside diameter
 M1/M2=metric connecting threads

D1/D2=Ø exterior del tubo
 M1/M2=rosca métrica conexión

Konus-Reduzieranschlussstutzen mit Schaft

schaftseitig vormontiert

Reducing taper standpipe connectors

pre-assembled on standpipe side

Cuerpos de reducción cónicas con vástago

premontado en lado de vástago

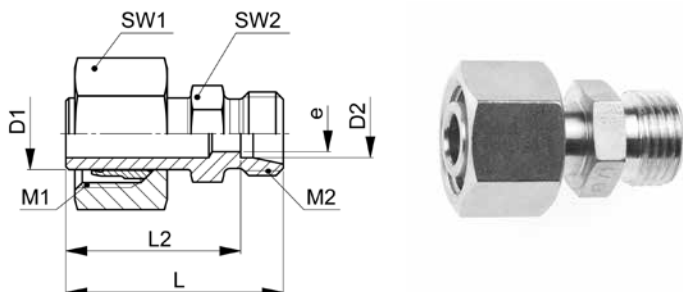

XKR-..L M

Type-D1 /D2	Mat.-Nr.	PN	M1	M2	L	L2	SW1	SW2	e	g/Stk
XKR-08/06L M	707.1821.140.20	500	14x1.5	12x1.5	35.0	28.0	17	12	4.0	30
XKR-10/06L M	707.1821.175.20	500	16x1.5	12x1.5	34.5	27.5	19	12	4.0	40
XKR-10/08L M	707.1821.190.20	500	16x1.5	14x1.5	35.5	28.5	19	14	6.5	38
XKR-12/06L M	707.1821.215.20	400	18x1.5	12x1.5	36.5	29.5	22	14	4.0	52
XKR-12/08L M	707.1821.225.20	400	18x1.5	14x1.5	36.5	29.5	22	14	6.0	52
XKR-12/10L M	707.1821.240.20	400	18x1.5	16x1.5	37.5	30.5	22	17	8.0	54
XKR-15/06L M	707.1821.391.20	400	22x1.5	12x1.5	37.0	30.0	27	17	4.0	70
XKR-15/08L M	707.1821.400.20	400	22x1.5	14x1.5	37.0	30.0	27	17	6.0	82
XKR-15/10L M	707.1821.410.20	400	22x1.5	16x1.5	38.0	31.0	27	17	8.0	80
XKR-15/12L M	707.1821.420.20	400	22x1.5	18x1.5	39.0	32.0	27	19	10.0	74
XKR-18/06L M	707.1821.563.20	400	26x1.5	12x1.5	38.5	31.5	32	19	4.0	96
XKR-18/08L M	707.1821.570.20	400	26x1.5	14x1.5	38.5	31.5	32	19	6.0	106
XKR-18/10L M	707.1821.575.20	400	26x1.5	16x1.5	38.5	31.5	32	19	8.0	122
XKR-18/12L M	707.1821.580.20	400	26x1.5	18x1.5	38.5	31.5	32	19	10.0	120
XKR-18/15L M	707.1821.610.20	400	26x1.5	22x1.5	39.5	32.5	32	24	12.0	128
XKR-22/06L M	707.1821.723.20	250	30x2.0	12x1.5	38.5	31.5	36	24	4.0	122
XKR-22/08L M	707.1821.724.20	250	30x2.0	14x1.5	38.5	31.5	36	24	6.0	129
XKR-22/10L M	707.1821.725.20	250	30x2.0	16x1.5	39.5	32.5	36	24	8.0	138
XKR-22/12L M	707.1821.730.20	250	30x2.0	18x1.5	39.5	32.5	36	24	10.0	150
XKR-22/15L M	707.1821.745.20	250	30x2.0	22x1.5	40.5	33.5	36	24	12.0	176
XKR-22/18L M	707.1821.755.20	250	30x2.0	26x1.5	41.5	34.0	36	27	15.0	178
XKR-28/06L M	707.1821.828.20	250	36x2.0	12x1.5	41.0	34.0	41	30	4.0	130
XKR-28/08L M	707.1821.829.20	250	36x2.0	14x1.5	41.0	34.0	41	30	6.0	140
XKR-28/10L M	707.1821.830.20	250	36x2.0	16x1.5	42.0	35.0	41	30	8.0	150
XKR-28/12L M	707.1821.835.20	250	36x2.0	18x1.5	42.0	35.0	41	30	10.0	170
XKR-28/15L M	707.1821.865.20	250	36x2.0	22x1.5	43.0	36.0	41	30	12.0	190
XKR-28/18L M	707.1821.870.20	250	36x2.0	26x1.5	43.0	35.5	41	30	15.0	210
XKR-28/22L M	707.1821.900.20	250	36x2.0	30x2.0	45.0	37.5	41	32	19.0	240

Fortsetzung auf nächster linker Seite

To be continued on next left page

Continuación próxima página izquierda

D1/D2=Rohr außen-Ø
M1/M2=metrische Anschlußgewinde
e=kleinster Innen-Ø

D1/D2=tube outside diameters
M1/M2=metric connecting threads
e=minimum inside diameter

D1/D2=Ø exteriores de los tubos
M1/M2=rosca métrica conexión
e=Ø interior mínimo

Konus-Reduzieranschlüsse mit Schaft

Reducing taper standpipe fittings

Conexiones de reducción cónicas con vástago

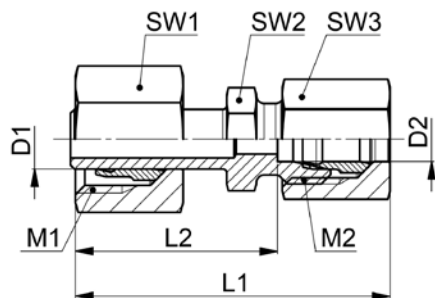

KR-..L

Type-D1 /D2	Mat.-Nr.	PN	M1	M2	L1	L2	SW1	SW2	SW3	g/Stk
KR-08/06L	708.1820.140.20	500	14x1.5	12x1.5	43.0	28.0	17	12	14	42
KR-10/06L	708.1820.175.20	500	16x1.5	12x1.5	42.5	27.5	19	12	14	55
KR-10/08L	708.1820.190.20	500	16x1.5	14x1.5	43.5	28.5	19	14	17	58
KR-12/06L	708.1820.215.20	400	18x1.5	12x1.5	44.5	29.5	22	14	14	63
KR-12/08L	708.1820.225.20	400	18x1.5	14x1.5	44.5	29.5	22	14	17	70
KR-12/10L	708.1820.240.20	400	18x1.5	16x1.5	45.5	30.5	22	17	19	72
KR-15/06L	708.1820.391.20	400	22x1.5	12x1.5	45.0	30.0	27	17	14	95
KR-15/08L	708.1820.400.20	400	22x1.5	14x1.5	45.0	30.0	27	17	17	98
KR-15/10L	708.1820.410.20	400	22x1.5	16x1.5	46.0	31.0	27	17	19	100
KR-15/12L	708.1820.420.20	400	22x1.5	18x1.5	47.0	32.0	27	19	22	104
KR-18/06L	708.1820.563.20	400	26x1.5	12x1.5	46.5	31.5	32	19	14	133
KR-18/08L	708.1820.570.20	400	26x1.5	14x1.5	46.5	31.5	32	19	17	135
KR-18/10L	708.1820.575.20	400	26x1.5	16x1.5	46.5	31.5	32	19	19	140
KR-18/12L	708.1820.580.20	400	26x1.5	18x1.5	46.5	31.5	32	19	22	145
KR-18/15L	708.1820.610.20	400	26x1.5	22x1.5	47.5	32.5	32	24	27	165
KR-22/06L	708.1820.723.20	250	30x2.0	12x1.5	46.5	31.5	36	24	14	152
KR-22/08L	708.1820.724.20	250	30x2.0	14x1.5	46.5	31.5	36	24	17	157
KR-22/10L	708.1820.725.20	250	30x2.0	16x1.5	47.5	32.5	36	24	19	170
KR-22/12L	708.1820.730.20	250	30x2.0	18x1.5	47.5	32.5	36	24	22	186
KR-22/15L	708.1820.745.20	250	30x2.0	22x1.5	48.5	33.5	36	24	27	214
KR-22/18L	708.1820.755.20	250	30x2.0	26x1.5	50.5	34.0	36	27	32	245
KR-28/06L	708.1820.828.20	250	36x2.0	12x1.5	49.0	34.0	41	30	14	185
KR-28/08L	708.1820.829.20	250	36x2.0	14x1.5	49.0	34.0	41	30	17	190
KR-28/10L	708.1820.830.20	250	36x2.0	16x1.5	50.0	35.0	41	30	19	215
KR-28/12L	708.1820.835.20	250	36x2.0	18x1.5	50.0	35.0	41	30	22	214
KR-28/15L	708.1820.865.20	250	36x2.0	22x1.5	51.0	36.0	41	30	27	245
KR-28/18L	708.1820.870.20	250	36x2.0	26x1.5	52.0	35.5	41	30	32	257
KR-28/22L	708.1820.900.20	250	36x2.0	30x2.0	54.5	37.5	41	32	36	310

Fortsetzung auf nächster rechter Seite

To be continued on next right page

Continuación próxima página derecha

Konus-Reduzieranschlussstutzen mit Schaft

schaftseitig vormontiert

Reducing taper standpipe connectors

pre-assembled on standpipe side

Cuerpos de reducción cónicas con vástago

premontado en lado de vástago

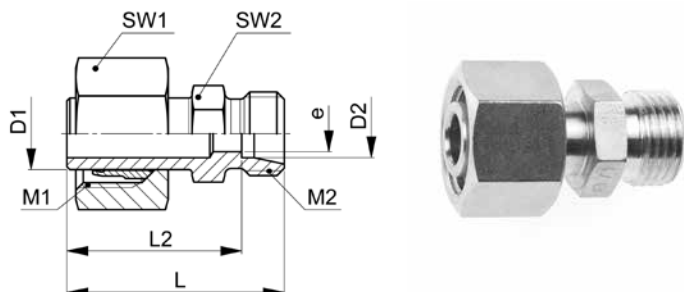

XKR-..L M

Type-D1 /D2	Mat.-Nr.	PN	M1	M2	L	L2	SW1	SW2	e	g/Stk
XKR-35/06L M	707.1821.951.20	250	45x2.0	12x1.5	50.5	43.5	50	36	4.0	318
XKR-35/08L M	707.1821.952.20	250	45x2.0	14x1.5	50.5	43.0	50	36	6.0	324
XKR-35/10L M	707.1821.953.20	250	45x2.0	16x1.5	52.5	45.0	50	36	8.0	328
XKR-35/12L M	707.1821.954.20	250	45x2.0	18x1.5	52.5	45.0	50	41	8.0	404
XKR-35/15L M	707.1821.946.20	250	45x2.0	22x1.5	48.5	41.5	50	36	12.0	272
XKR-35/18L M	707.1821.947.20	250	45x2.0	26x1.5	48.5	41.5	50	36	15.0	282
XKR-35/22L M	707.1821.948.20	250	45x2.0	30x2.0	49.5	42.5	50	36	15.0	292
XKR-35/28L M	707.1821.949.20	250	45x2.0	36x2.0	49.5	42.5	50	36	24.0	312
XKR-42/10L M	707.1821.988.20	250	52x2.0	16x1.5	52.5	45.5	60	46	8.0	482
XKR-42/12L M	707.1821.989.20	250	52x2.0	18x1.5	52.5	45.5	60	46	10.0	488
XKR-42/15L M	707.1821.991.20	250	52x2.0	22x1.5	53.5	46.5	60	46	12.0	490
XKR-42/18L M	707.1821.992.20	250	52x2.0	26x1.5	53.5	46.0	60	46	15.0	500
XKR-42/22L M	707.1821.993.20	250	52x2.0	30x2.0	55.5	48.0	60	46	19.0	512
XKR-42/28L M	707.1821.994.20	250	52x2.0	36x2.0	55.5	48.0	60	46	24.0	518
XKR-42/35L M	707.1821.996.20	250	52x2.0	45x2.0	57.5	47.0	60	46	30.0	588

Achtung: Für Endmontage des vormontierten Schaftes Überwurfmutter mit 1/4 Umdrehung über den Punkt des deutlich fühlbaren Kraftanstiegs anziehen.

For final assembly of the pre-assembled standpipe, tighten the union nut by 1/4 turn beyond the point of the clearly perceptible increase in force.

Atención: Para el ensamblaje final del vástago premontado, apriete la tuerca de unión 1/4 de vuelta más allá del punto del aumento claramente perceptible de la resistencia.

D1/D2=Rohr außen-Ø
M1/M2=metrische Anschlußgewinde
e=kleinster Innen-Ø

D1/D2=tube outside diameters
M1/M2=metric connecting threads
e=minimum inside diameter

D1/D2=Ø exteriores de los tubos
M1/M2=rosca métrica conexión
e=Ø interior mínimo

Konus-Reduzieranschlüsse mit Schaft

Reducing taper standpipe fittings

Conexiones de reducción cónicas con vástago

10

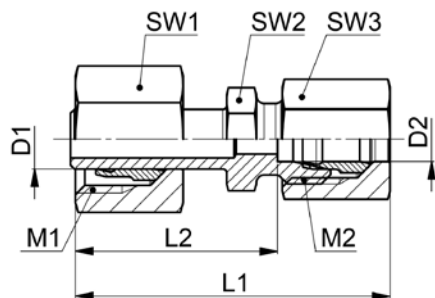

KR-..L

Type-D1 /D2	Mat.-Nr.	PN	M1	M2	L1	L2	SW1	SW2	SW3	g/Stk
KR-35/06L	708.1820.951.20	250	45x2.0	12x1.5	56.5	41.5	50	36	14	314
KR-35/08L	708.1820.952.20	250	45x2.0	14x1.5	56.5	41.5	50	36	17	318
KR-35/10L	708.1820.953.20	250	45x2.0	16x1.5	57.5	42.5	50	36	19	325
KR-35/12L	708.1820.954.20	250	45x2.0	18x1.5	57.5	45.0	50	36	22	345
KR-35/15L	708.1820.946.20	250	45x2.0	22x1.5	58.5	43.5	50	36	27	368
KR-35/18L	708.1820.947.20	250	45x2.0	26x1.5	59.5	43.0	50	36	32	392
KR-35/22L	708.1820.948.20	250	45x2.0	30x2.0	61.5	45.0	50	36	36	480
KR-35/28L	708.1820.949.20	250	45x2.0	36x2.0	61.5	45.0	50	41	41	426
KR-42/10L	708.1820.988.20	250	52x2.0	16x1.5	60.5	45.5	60	46	19	515
KR-42/12L	708.1820.989.20	250	52x2.0	18x1.5	60.5	45.5	60	46	22	524
KR-42/15L	708.1820.991.20	250	52x2.0	22x1.5	61.5	46.5	60	46	27	530
KR-42/18L	708.1820.992.20	250	52x2.0	26x1.5	62.5	46.0	60	46	32	530
KR-42/22L	708.1820.993.20	250	52x2.0	30x2.0	64.5	48.0	60	46	36	540
KR-42/28L	708.1820.994.20	250	52x2.0	36x2.0	64.5	48.0	60	46	41	576
KR-42/35L	708.1820.996.20	250	52x2.0	45x2.0	68.5	47.0	60	46	50	640

Baumaße sind Ungefährmaße bei angezogener Überwurfmutter.

Sizes are approximate dimensions at tightened nut.

Las medidas son aproximadas con la tuerca de unión apretada.

Achtung: Für Endmontage des vormontierten Schaftes Überwurfmutter mit 1/4 Umdrehung über den Punkt des deutlich fühlbaren Kraftanstiegs anziehen.

Attention: For final assembly of the pre-assembled standpipe, tighten the union nut by 1/4 turn beyond the point of the clearly perceptible increase in force.

Atención: Para el ensamblaje final del vástago premontado, apriete la tuerca de unión 1/4 de vuelta más allá del punto del aumento claramente perceptible de la resistencia.

Konus-Reduzieranschlussstutzen mit Schaft

schaftseitig vormontiert

Reducing taper standpipe connectors

pre-assembled on standpipe side

Cuerpos de reducción cónicas con vástago

premontado en lado de vástago

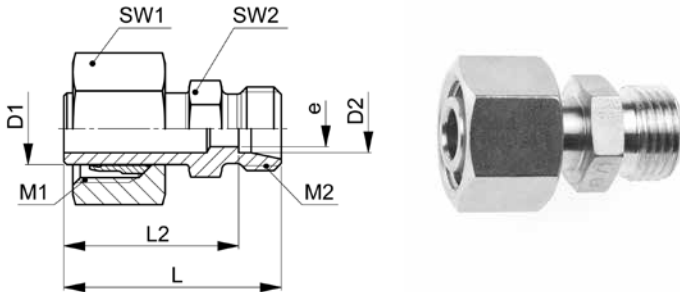

XKR-..S M

Type-D1 /D2	Mat.-Nr.	PN	M1	M2	L	L2	SW1	SW2	e	g/Stk
XKR-08/06S M	707.1821.140.30	800	16x1.5	14x1.5	38.5	31.5	19	14	4.3	48
XKR-10/06S M	707.1821.175.30	800	18x1.5	14x1.5	40.5	33.5	22	14	4.0	60
XKR-10/08S M	707.1821.190.30	800	18x1.5	16x1.5	41.0	34.0	22	17	6.0	68
XKR-12/06S M	707.1821.215.30	630	20x1.5	14x1.5	40.0	33.0	24	14	4.0	68
XKR-12/08S M	707.1821.225.30	630	20x1.5	16x1.5	40.5	33.0	24	17	5.0	74
XKR-12/10S M	707.1821.240.30	630	20x1.5	18x1.5	40.5	33.0	24	19	7.0	76
XKR-14/06S M	707.1821.296.30	630	22x1.5	14x1.5	42.0	35.0	27	17	4.0	102
XKR-14/08S M	707.1821.300.30	630	22x1.5	16x1.5	42.0	35.0	27	17	5.0	108
XKR-14/10S M	707.1821.320.30	630	22x1.5	18x1.5	42.0	34.5	27	19	7.0	112
XKR-14/12S M	707.1821.340.30	630	22x1.5	20x1.5	43.0	35.5	27	22	9.0	118
XKR-16/06S M	707.1821.466.30	630	24x1.5	14x1.5	43.0	36.0	30	17	4.0	110
XKR-16/08S M	707.1821.468.30	630	24x1.5	16x1.5	43.0	36.0	30	17	5.0	116
XKR-16/10S M	707.1821.470.30	630	24x1.5	18x1.5	43.0	35.5	30	19	7.0	130
XKR-16/12S M	707.1821.480.30	630	24x1.5	20x1.5	44.0	36.5	30	22	8.0	142
XKR-16/14S M	707.1821.500.30	630	24x1.5	22x1.5	47.0	39.0	30	24	10.5	152
XKR-20/06S M	707.1821.650.30	420	30x2.0	14x1.5	49.0	42.0	36	22	4.0	176
XKR-20/08S M	707.1821.655.30	420	30x2.0	16x1.5	49.0	42.0	36	22	5.0	182
XKR-20/10S M	707.1821.660.30	420	30x2.0	18x1.5	49.0	41.5	36	22	7.0	186
XKR-20/12S M	707.1821.665.30	420	30x2.0	20x1.5	49.0	41.5	36	22	8.0	192
XKR-20/14S M	707.1821.675.30	420	30x2.0	22x1.5	52.0	44.0	36	24	10.0	220
XKR-20/16S M	707.1821.685.30	420	30x2.0	24x1.5	52.0	43.5	36	27	12.0	224
XKR-25/06S M	707.1821.788.30	420	36x2.0	14x1.5	53.0	46.0	46	27	5.0	332
XKR-25/08S M	707.1821.787.30	420	36x2.0	16x1.5	53.0	46.0	46	27	4.0	330
XKR-25/10S M	707.1821.789.30	420	36x2.0	18x1.5	53.0	45.5	46	27	7.0	334
XKR-25/12S M	707.1821.791.30	420	36x2.0	20x1.5	55.0	47.0	46	27	10.0	365
XKR-25/14S M	707.1821.790.30	420	36x2.0	22x1.5	53.0	45.5	46	27	8.0	344
XKR-25/16S M	707.1821.795.30	420	36x2.0	24x1.5	55.0	46.5	46	27	12.0	380
XKR-25/20S M	707.1821.820.30	420	36x2.0	30x2.0	58.0	47.5	46	32	17.0	400

Fortsetzung auf nächster linker Seite

To be continued on next left page

Continuación próxima página izquierda

D1/D2=Rohr außen-Ø
M1/M2=metrische Anschlußgewinde
e=kleinster Innen-Ø

D1/D2=tube outside diameters
M1/M2=metric connecting threads
e=minimum inside diameter

D1/D2=Ø exteriores de los tubos
M1/M2=rosca métrica conexión
e=Ø interior mínimo

Konus-Reduzieranschlüsse mit Schaft

Reducing taper standpipe fittings

Conexiones de reducción cónicas con vástago

10

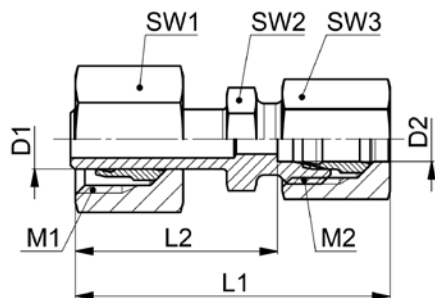

KR-..S

Type-D1 /D2	Mat.-Nr.	PN	M1	M2	L1	L2	SW1	SW2	SW3	g/Stk
KR-08/06S	708.1820.140.30	800	16x1.5	14x1.5	46.5	31.5	19	14	17	68
KR-10/06S	708.1820.175.30	800	18x1.5	14x1.5	48.5	33.5	22	14	17	80
KR-10/08S	708.1820.190.30	800	18x1.5	16x1.5	49.0	34.0	22	17	19	85
KR-12/06S	708.1820.215.30	630	20x1.5	14x1.5	48.0	33.0	24	14	17	90
KR-12/08S	708.1820.225.30	630	20x1.5	16x1.5	48.5	33.5	24	17	19	98
KR-12/10S	708.1820.240.30	630	20x1.5	18x1.5	49.5	33.0	24	19	22	100
KR-14/06S	708.1820.296.30	630	22x1.5	14x1.5	50.0	35.0	27	17	17	105
KR-14/08S	708.1820.300.30	630	22x1.5	16x1.5	50.0	35.0	27	17	19	110
KR-14/10S	708.1820.320.30	630	22x1.5	18x1.5	51.0	34.5	27	19	22	125
KR-14/12S	708.1820.340.30	630	22x1.5	20x1.5	52.0	35.5	27	22	24	130
KR-16/06S	708.1820.466.30	630	24x1.5	14x1.5	51.0	36.0	30	17	17	135
KR-16/08S	708.1820.468.30	630	24x1.5	16x1.5	51.0	36.0	30	17	19	140
KR-16/10S	708.1820.470.30	630	24x1.5	18x1.5	52.0	35.5	30	19	22	145
KR-16/12S	708.1820.480.30	630	24x1.5	20x1.5	53.0	36.5	30	22	24	150
KR-16/14S	708.1820.500.30	630	24x1.5	22x1.5	57.0	39.0	30	24	27	169
KR-20/06S	708.1820.650.30	420	30x2.0	14x1.5	57.0	42.0	36	22	17	195
KR-20/08S	708.1820.655.30	420	30x2.0	16x1.5	57.0	42.0	36	22	19	203
KR-20/10S	708.1820.660.30	420	30x2.0	18x1.5	58.0	41.5	36	22	22	220
KR-20/12S	708.1820.665.30	420	30x2.0	20x1.5	58.0	41.5	36	22	24	240
KR-20/14S	708.1820.675.30	420	30x2.0	22x1.5	62.0	44.0	36	24	27	250
KR-20/16S	708.1820.685.30	420	30x2.0	24x1.5	62.0	43.5	36	27	30	265
KR-25/06S	708.1820.788.30	420	36x2.0	14x1.5	61.0	46.0	46	27	17	350
KR-25/08S	708.1820.787.30	420	36x2.0	16x1.5	61.0	46.0	46	27	19	360
KR-25/10S	708.1820.789.30	420	36x2.0	18x1.5	62.0	45.5	46	27	22	430
KR-25/12S	708.1820.791.30	420	36x2.0	20x1.5	62.0	45.5	46	27	24	384
KR-25/14S	708.1820.790.30	420	36x2.0	22x1.5	65.0	47.0	46	27	27	381
KR-25/16S	708.1820.795.30	420	36x2.0	24x1.5	65.0	46.5	46	27	30	405
KR-25/20S	708.1820.820.30	420	36x2.0	30x2.0	69.0	47.5	46	32	36	415

Fortsetzung auf nächster rechter Seite

To be continued on next right page

Continuación próxima página derecha

D1/D2=Rohr außen-Ø
M1/M2=metrische Anschlußgewinde

D1/D2=tube outside diameters
M1/M2=metric connecting threads

D1/D2=Ø exteriores de los tubos
M1/M2=rosca métrica conexión

Konus-Reduzieranschlussstutzen mit Schaft

schaftseitig vormontiert

Reducing taper standpipe connectors

pre-assembled on standpipe side

Cuerpos de reducción cónicas con vástago

premontado en lado de vástago

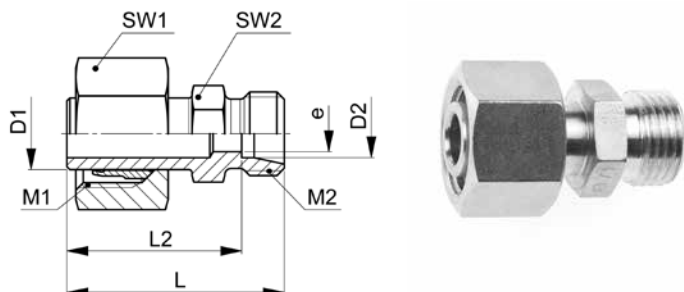

XKR-..S M

Type-D1 /D2	Mat.-Nr.	PN	M1	M2	L	L2	SW1	SW2	e	g/Stk
XKR-30/06S M	707.1821.937.30	420	42x2.0	14x1.5	56.5	49.5	50	32	5.0	418
XKR-30/08S M	707.1821.936.30	420	42x2.0	16x1.5	56.5	49.5	50	32	4.0	408
XKR-30/10S M	707.1821.939.30	420	42x2.0	18x1.5	56.5	49.0	50	32	7.0	428
XKR-30/12S M	707.1821.940.30	420	42x2.0	20x1.5	56.5	49.0	50	32	8.0	430
XKR-30/14S M	707.1821.941.30	420	42x2.0	22x1.5	58.5	50.5	50	32	10.0	502
XKR-30/16S M	707.1821.942.30	420	42x2.0	24x1.5	58.5	50.0	50	32	12.0	518
XKR-30/20S M	707.1821.943.30	420	42x2.0	30x2.0	60.5	50.0	50	32	16.0	532
XKR-30/25S M	707.1821.945.30	420	42x2.0	36x2.0	63.5	51.5	50	41	20.0	582
XKR-38/06S M	707.1821.965.30	420	52x2.0	14x1.5	62.0	55.0	60	41	4.0	605
XKR-38/08S M	707.1821.966.30	420	52x2.0	16x1.5	62.0	55.0	60	41	5.0	612
XKR-38/10S M	707.1821.967.30	420	52x2.0	18x1.5	62.0	54.5	60	41	7.0	622
XKR-38/12S M	707.1821.968.30	420	52x2.0	20x1.5	62.0	54.5	60	41	8.0	634
XKR-38/14S M	707.1821.969.30	420	52x2.0	22x1.5	64.0	56.0	60	41	10.0	645
XKR-38/16S M	707.1821.970.30	420	52x2.0	24x1.5	64.0	55.5	60	41	12.0	656
XKR-38/20S M	707.1821.971.30	420	52x2.0	30x2.0	66.0	55.5	60	41	16.0	674
XKR-38/25S M	707.1821.972.30	420	52x2.0	36x2.0	68.0	56.0	60	41	20.0	708
XKR-38/30S M	707.1821.975.30	420	52x2.0	42x2.0	72.0	58.5	60	46	25.0	818

Achtung: Für Endmontage des vormontierten Schaftes Überwurfmutter mit 1/4 Umdrehung über den Punkt des deutlich fühlbaren Kraftanstiegs anziehen.

For final assembly of the pre-assembled standpipe, tighten the union nut by 1/4 turn beyond the point of the clearly perceptible increase in force.

Atención: Para el ensamblaje final del vástago premontado, apriete la tuerca de unión 1/4 de vuelta más allá del punto del aumento claramente perceptible de la resistencia.

D1/D2=Rohr außen-Ø
M1/M2=metrische Anschlußgewinde
e=kleinster Innen-Ø

D1/D2=tube outside diameters
M1/M2=metric connecting threads
e=minimum inside diameter

D1/D2=Ø exteriores de los tubos
M1/M2=rosca métrica conexión
e=Ø interior mínimo

Konus-Reduzieranschlüsse mit Schaft

Reducing taper standpipe fittings

Conexiones de reducción cónicas con vástago

10

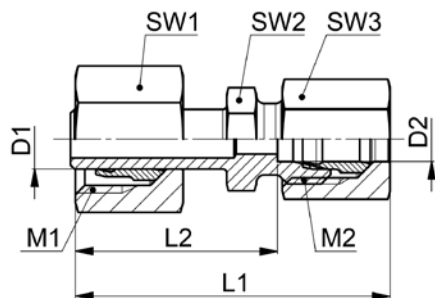

KR-..S

Type-D1 /D2	Mat.-Nr.	PN	M1	M2	L1	L2	SW1	SW2	SW3	g/Stk
KR-30/06S	708.1820.937.30	420	42x2.0	14x1.5	64.5	49.5	50	32	17	390
KR-30/08S	708.1820.936.30	420	42x2.0	16x1.5	64.5	49.5	50	32	19	405
KR-30/10S	708.1820.939.30	420	42x2.0	18x1.5	65.5	49.0	50	32	22	410
KR-30/12S	708.1820.940.30	420	42x2.0	20x1.5	65.5	49.0	50	32	24	414
KR-30/14S	708.1820.941.30	420	42x2.0	22x1.5	68.5	50.5	50	32	27	465
KR-30/16S	708.1820.942.30	420	42x2.0	24x1.5	68.5	50.0	50	32	30	467
KR-30/20S	708.1820.943.30	420	42x2.0	30x2.0	71.5	50.0	50	32	36	510
KR-30/25S	708.1820.945.30	420	42x2.0	36x2.0	75.5	51.5	50	41	46	632
KR-38/06S	708.1820.965.30	420	52x2.0	14x1.5	70.0	55.0	60	41	17	545
KR-38/08S	708.1820.966.30	420	52x2.0	16x1.5	70.0	55.0	60	41	19	555
KR-38/10S	708.1820.967.30	420	52x2.0	18x1.5	71.0	54.5	60	41	22	575
KR-38/12S	708.1820.968.30	420	52x2.0	20x1.5	71.0	54.5	60	41	24	580
KR-38/14S	708.1820.969.30	420	52x2.0	22x1.5	74.0	56.0	60	41	27	617
KR-38/16S	708.1820.970.30	420	52x2.0	24x1.5	74.0	55.5	60	41	30	620
KR-38/20S	708.1820.971.30	420	52x2.0	30x2.0	77.0	55.5	60	41	36	820
KR-38/25S	708.1820.972.30	420	52x2.0	36x2.0	80.0	56.0	60	41	46	880
KR-38/30S	708.1820.975.30	420	52x2.0	42x2.0	85.0	58.5	60	46	50	910

Baumaße sind Ungefährmaße bei angezogener Überwurfmutter.

Sizes are approximate dimensions at tightened nut.

Las medidas son aproximadas con la tuerca de unión apretada.

Achtung: Für Endmontage des vormontierten Schaftes Überwurfmutter mit 1/4 Umdrehung über den Punkt des deutlich fühlbaren Kraftanstiegs anziehen.

Attention: For final assembly of the pre-assembled standpipe, tighten the union nut by 1/4 turn beyond the point of the clearly perceptible increase in force.

Atención: Para el ensamblaje final del vástago premontado, apriete la tuerca de unión 1/4 de vuelta más allá del punto del aumento claramente perceptible de la resistencia.

T-Reduzierstutzen

Reducing T connectors

Cuerpos de reducción T

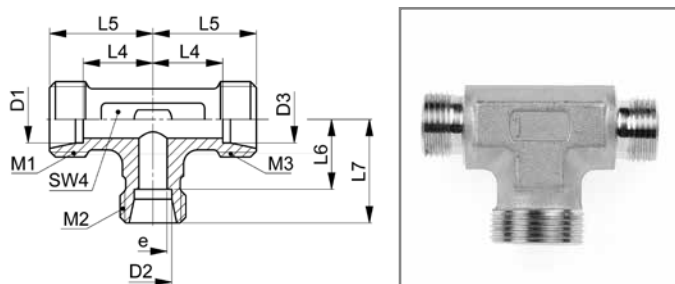

XTR-..L/S

Type -D1 /D2 /D3	Mat.-Nr.	PN	M1	M2	M3	L4	L5	L6	L7	SW4	e	g/Stk
XTR-06/08/06L	706.3004.058.20	500	12x1.5	14x1.5	12x1.5	14.0	21.0	14.0	21.0	12	4.0	37
XTR-06/10/06L	706.3004.061.20	500	12x1.5	16x1.5	16x1.5	15.0	22.0	15.0	22.0	14	4.0	48
XTR-08/06/08L	706.3004.093.20	500	14x1.5	12x1.5	14x1.5	14.0	21.0	14.0	21.0	12	4.0	30
XTR-08/10/08L	706.3004.104.20	500	14x1.5	16x1.5	14x1.5	15.0	22.0	15.0	22.0	14	6.0	48
XTR-10/06/10L	706.3004.147.20	500	12x1.5	12x1.5	12x1.5	15.0	22.0	15.0	22.0	14	4.0	40
XTR-10/08/10L	706.3004.153.20	500	16x1.5	14x1.5	16x1.5	15.0	22.0	15.0	22.0	14	6.0	47
XTR-10/10/08L	706.3004.160.20	500	16x1.5	16x1.5	14x1.5	15.0	22.0	15.0	22.0	14	6.0	47
XTR-10/15/10L	706.3004.175.20	500	16x1.5	22x1.5	16x1.5	21.0	28.0	21.0	28.0	19	8.0	111
XTR-12/08/12L	706.3004.210.20	400	18x1.5	14x1.5	18x1.5	17.0	24.0	17.0	24.0	17	6.0	64
XTR-12/10/12L	706.3004.222.20	400	18x1.5	16x1.5	18x1.5	17.0	24.0	17.0	24.0	17	8.0	63
XTR-12/12/10L	706.3004.232.20	400	18x1.5	18x1.5	16x1.5	17.0	24.0	17.0	24.0	17	8.0	64
XTR-12/18/12L	706.3004.258.20	400	18x1.5	26x1.5	18x1.5	24.0	31.0	23.5	31.0	24	10.0	140
XTR-15/10/15L	706.3004.410.20	400	22x1.5	16x1.5	22x1.5	21.0	28.0	21.0	28.0	19	8.0	110
XTR-15/12/12L	706.3004.417.20	400	22x1.5	18x1.5	18x1.5	21.0	28.0	21.0	28.0	19	10.0	109
XTR-15/12/15L	706.3004.422.20	400	22x1.5	18x1.5	22x1.5	21.0	28.0	21.0	28.0	19	10.0	109
XTR-15/15/12L	706.3004.435.20	400	22x1.5	22x1.5	18x1.5	21.0	28.0	21.0	28.0	19	10.0	109
XTR-18/10/10L	706.3004.575.20	400	26x1.5	16x1.5	16x1.5	23.5	31.0	24.0	31.0	24	8.0	190
XTR-18/10/18L	706.3004.584.20	400	26x1.5	16x1.5	26x1.5	23.5	31.0	24.0	31.0	24	8.0	180
XTR-18/12/18L	706.3004.599.20	400	26x1.5	18x1.5	26x1.5	23.5	31.0	23.5	31.0	24	10.0	150
XTR-18/15/18L	706.3004.628.20	400	26x1.5	22x1.5	26x1.5	23.5	31.0	24.0	31.0	24	12.0	162
XTR-18/18/10L	706.3004.637.20	400	26x1.5	26x1.5	16x1.5	23.5	31.0	23.5	31.0	24	9.0	162
XTR-22/10/22L	706.3004.738.20	250	30x2.0	16x1.5	30x2.0	27.5	35.0	28.0	35.0	27	8.0	270
XTR-22/12/22L	706.3004.740.20	250	30x2.0	18x1.5	30x2.0	27.5	35.0	28.0	35.0	27	10.0	270
XTR-22/15/22L	706.3004.800.20	250	30x2.0	22x1.5	30x2.0	27.5	35.0	28.0	35.0	27	12.0	270
XTR-22/18/18L	706.3004.854.20	250	30x2.0	26x1.5	26x1.5	27.5	35.0	27.5	35.0	27	15.0	257
XTR-22/18/22L	706.3004.862.20	250	30x2.0	26x1.5	30x2.0	27.5	35.0	28.0	35.0	27	15.0	239
XTR-28/10/28L	706.3004.906.20	250	16x1.5	16x1.5	36x2.0	30.5	38.0	31.0	38.0	36	8.0	370
XTR-28/12/28L	706.3004.916.20	250	36x2.0	18x1.5	36x2.0	30.5	38.0	31.0	38.0	36	10.0	380
XTR-28/15/28L	706.3004.920.20	250	36x2.0	22x1.5	36x2.0	30.5	38.0	31.0	38.0	36	12.0	381
XTR-28/18/28L	706.3004.928.20	250	36x2.0	26x1.5	36x2.0	30.5	38.0	30.5	38.0	36	15.0	382
XTR-28/22/22L	706.3004.946.20	250	36x2.0	30x2.0	30x2.0	30.5	38.0	30.5	38.0	36	19.0	383
XTR-28/22/28L	706.3004.948.20	250	36x2.0	30x2.0	36x2.0	30.5	38.0	30.5	38.0	36	19.0	361
XTR-12/16/12S	706.3004.256.30	630	20x1.5	24x1.5	20x1.5	25.5	33.0	24.5	33.0	24	8.0	170
XTR-16/10/16S	706.3004.454.30	630	24x1.5	18x1.5	18x1.5	24.5	33.0	25.5	33.0	24	8.0	198
XTR-16/12/16S	706.3004.455.30	630	24x1.5	20x1.5	24x1.5	24.5	33.0	25.5	33.0	24	9.0	198
XTR-20/10/20S	706.3004.675.30	420	30x2.0	16x1.5	30x2.0	26.5	37.0	29.5	37.0	27	8.0	292
XTR-20/12/20S	706.3004.680.30	420	30x2.0	20x1.5	30x2.0	26.5	37.0	25.5	33.0	27	9.0	278
XTR-25/16/25S	706.3004.900.30	420	36x2.0	24x1.5	36x2.0	30.0	42.0	33.5	42.0	36	12.0	489
XTR-30/16/30S	706.3004.970.30	420	42x2.0	24x1.5	42x2.0	35.5	49.0	40.5	49.0	41	14.0	750

D1/D2/D3=Rohr außen-Ø
M1/M2/M3=metrische Anschlußgewinde
e=kleinster Innen-Ø

D1/D2/D3=tube outside diameter
M1/M2/M3=metric connecting threads
e=minimum inside diameter

D1/D2/D3=Ø exterior del tubo
M1/M2/M3=rosca métrica conexión
e=Ø interior mínimo

T-Reduzierschraubungen
Reducing T fittings
Racores de reducción T

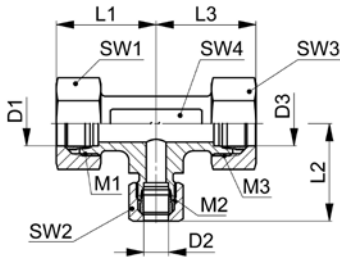

10

TR-..L/S

Type -D1 /D2 /D3	Mat.-Nr.	PN	M1	M2	M3	L1	L2	L3	SW1	SW2	SW3	SW4	g/Stk
TR-06/08/06L	708.3004.058.20	500	12x1.5	14x1.5	12x1.5	29.0	29.0	29.0	14	17	14	12	82
TR-06/10/06L	708.3004.061.20	500	12x1.5	16x1.5	12x1.5	30.0	30.5	30.0	14	19	14	14	97
TR-08/06/08L	708.3004.093.20	500	14x1.5	12x1.5	14x1.5	29.0	29.0	29.0	17	14	17	12	80
TR-08/10/08L	708.3004.104.20	500	14x1.5	16x1.5	14x1.5	30.0	30.5	30.0	17	19	17	14	109
TR-10/06/10L	708.3004.147.20	500	16x1.5	12x1.5	16x1.5	30.5	30.0	30.5	19	14	19	14	100
TR-10/08/10L	708.3004.153.20	500	16x1.5	14x1.5	16x1.5	30.5	30.0	30.5	19	17	19	14	113
TR-10/10/08L	708.3004.160.20	500	16x1.5	16x1.5	14x1.5	30.5	30.0	30.5	19	19	17	14	113
TR-10/15/10L	708.3004.175.20	400	16x1.5	22x1.5	16x1.5	36.5	37.0	36.5	19	27	19	19	208
TR-12/08/12L	708.3004.210.20	400	18x1.5	14x1.5	18x1.5	32.5	32.0	32.5	22	17	22	17	145
TR-12/10/12L	708.3004.222.20	400	18x1.5	16x1.5	18x1.5	32.5	32.5	32.5	22	19	22	17	150
TR-12/12/10L	708.3004.232.20	400	18x1.5	18x1.5	16x1.5	32.5	32.5	32.5	22	22	19	17	150
TR-12/18/12L	708.3004.258.20	400	18x1.5	26x1.5	18x1.5	39.5	40.5	39.5	22	32	22	24	276
TR-15/10/15L	708.3004.410.20	400	22x1.5	16x1.5	22x1.5	36.0	36.0	36.0	27	19	27	19	222
TR-15/12/12L	708.3004.417.20	400	22x1.5	18x1.5	18x1.5	37.0	36.5	36.5	27	22	22	19	227
TR-15/12/15L	708.3004.422.20	400	22x1.5	18x1.5	22x1.5	37.0	36.5	37.0	27	22	27	19	240
TR-15/15/12L	708.3004.435.20	400	22x1.5	22x1.5	18x1.5	36.0	36.0	36.0	27	27	22	19	227
TR-18/10/10L	708.3004.575.20	400	26x1.5	16x1.5	16x1.5	40.5	39.0	39.5	32	19	19	24	310
TR-18/10/18L	708.3004.584.20	400	26x1.5	16x1.5	26x1.5	40.5	39.5	40.5	32	19	32	24	370
TR-18/12/18L	708.3004.599.20	400	26x1.5	18x1.5	26x1.5	40.5	39.5	40.5	32	22	32	24	341
TR-18/15/18L	708.3004.628.20	400	26x1.5	22x1.5	26x1.5	40.0	39.0	40.0	32	27	32	24	343
TR-18/18/10L	708.3004.637.20	400	26x1.5	26x1.5	16x1.5	40.5	40.5	39.5	32	32	19	24	351
TR-22/10/22L	708.3004.738.20	250	30x2.0	16x1.5	30x2.0	44.5	43.5	44.5	36	19	36	27	486
TR-22/12/22L	708.3004.740.20	250	30x2.0	18x1.5	30x2.0	44.5	43.5	44.5	36	22	36	27	494
TR-22/15/22L	708.3004.800.20	250	30x2.0	22x1.5	30x2.0	44.5	44.0	44.5	36	27	36	27	513
TR-22/18/18L	708.3004.854.20	250	30x2.0	26x1.5	26x1.5	44.0	43.0	43.5	36	32	32	27	480
TR-22/18/22L	708.3004.862.20	250	30x2.0	26x1.5	30x2.0	44.5	44.5	44.5	36	32	36	27	506
TR-28/10/28L	708.3004.906.20	250	36x2.0	16x1.5	26x1.5	47.5	46.5	47.5	41	19	41	36	624
TR-28/12/28L	708.3004.916.20	250	36x2.0	18x1.5	36x2.0	47.5	46.5	47.5	41	22	41	36	643
TR-28/15/28L	708.3004.920.20	250	36x2.0	22x1.5	36x2.0	47.0	46.0	47.0	41	27	41	36	993
TR-28/18/28L	708.3004.928.20	250	36x2.0	26x1.5	36x2.0	47.5	47.5	47.5	41	32	41	36	685
TR-28/22/22L	708.3004.946.20	250	36x2.0	30x2.0	30x2.0	49.0	49.0	49.0	41	36	36	36	688
TR-28/22/28L	708.3004.948.20	250	36x2.0	30x2.0	36x2.0	47.5	47.5	47.5	41	36	41	36	688
TR-12/16/12S	708.3004.256.30	630	20x1.5	24x1.5	20x1.5	42.5	44.0	42.5	24	30	24	24	313
TR-16/10/16S	708.3004.454.30	630	24x1.5	18x1.5	24x1.5	44.0	42.5	44.0	30	22	30	24	419
TR-16/12/16S	708.3004.455.30	630	24x1.5	20x1.5	24x1.5	44.0	42.5	44.0	30	24	30	24	376
TR-20/10/20S	708.3004.675.30	420	30x2.0	16x1.5	30x2.0	48.0	46.0	48.0	36	22	36	27	548
TR-20/12/20S	708.3004.680.30	420	30x2.0	20x1.5	30x2.0	49.5	42.5	49.5	36	24	36	27	580
TR-25/16/25S	708.3004.900.30	420	36x2.0	24x1.5	36x2.0	55.5	53.0	55.5	46	30	46	36	1050
TR-30/16/30S	708.3004.970.30	420	42x2.0	24x1.5	42x2.0	63.5	60.0	63.5	50	30	50	41	1320

Baumaße sind Ungefährmaße bei angezogener Überwurfmutter.

Sizes are approximate dimensions at tightened nut.

Las medidas son aproximadas con la tuerca de unión apretada.

D1/D2/D3=Rohr außen-Ø
M1/M2/M3=metrische Anschlußgewinde

D1/D2/D3=tube outside diameter
M1/M2/M3=metric connecting threads

D1/D2/D3=Ø exterior del tubo
M1/M2/M3=rosca métrica conexión

Gerade Anschweißstutzen
Straight weld-on connectors
Cuerpos para soldar rectos

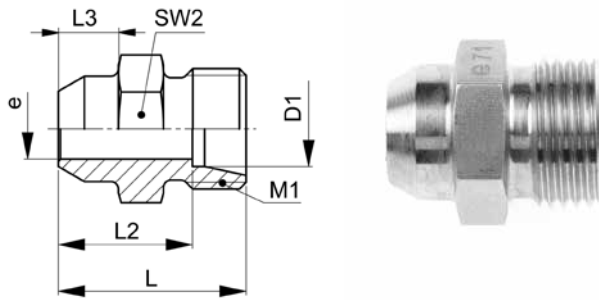

XGAS-..L/S

Type -D1	Mat.-Nr.	PN	M1	L	L2	L3	SW2	e	g/Stk
XGAS-06L	706.1400.060.20	500	12x1.5	21.0	14.0	7.0	12	4.0	10
XGAS-08L	706.1400.080.20	500	14x1.5	23.0	16.0	8.0	14	6.0	14
XGAS-10L	706.1400.100.20	500	16x1.5	25.0	18.0	8.0	17	8.0	22
XGAS-12L	706.1400.120.20	400	18x1.5	25.0	18.0	8.0	19	10.0	26
XGAS-15L	706.1400.150.20	400	22x1.5	29.0	22.0	10.0	22	12.0	48
XGAS-18L	706.1400.180.20	400	26x1.5	31.0	23.5	10.0	27	15.0	68
XGAS-22L	706.1400.220.20	250	30x2.0	36.0	28.5	12.0	32	19.0	98
XGAS-28L	706.1400.280.20	250	36x2.0	38.0	30.5	12.0	41	24.0	162
XGAS-35L	706.1400.350.20	250	45x2.0	43.0	32.5	14.0	46	30.0	238
XGAS-42L	706.1400.420.20	250	52x2.0	46.0	35.0	16.0	55	36.0	336
XGAS-06S	706.1400.060.30	800	14x1.5	26.0	19.0	7.0	14	4.0	18
XGAS-08S	706.1400.080.30	800	16x1.5	28.0	21.0	8.0	17	5.0	30
XGAS-10S	706.1400.100.30	800	18x1.5	30.0	22.5	8.0	19	7.0	40
XGAS-12S	706.1400.120.30	630	20x1.5	32.0	24.5	10.0	22	8.0	56
XGAS-14S	706.1400.140.30	630	22x1.5	35.0	27.0	10.0	24	10.0	70
XGAS-16S	706.1400.160.30	630	24x1.5	35.0	26.5	10.0	27	12.0	84
XGAS-20S	706.1400.200.30	420	30x2.0	40.0	29.5	12.0	32	16.0	130
XGAS-25S	706.1400.250.30	420	36x2.0	44.0	32.0	12.0	41	20.0	224
XGAS-30S	706.1400.300.30	420	42x2.0	49.0	35.5	14.0	46	25.0	302
XGAS-38S	706.1400.380.30	420	52x2.0	54.0	38.0	16.0	55	32.0	462

ISO 8434-1-WDS

D1=Rohr außen-Ø
M1=metrisches Anschlußgewinde
e=kleinster Innen-Ø

D1=tube outside diameter
M1=metric connecting thread
e=minimum inside diameter

D1=Ø exterior del tubo
M1=rosca métrica conexión
e=Ø interior mínimo

Gerade Anschweißverschraubungen
Straight weld-on fittings
Racores para soldar rectos

10

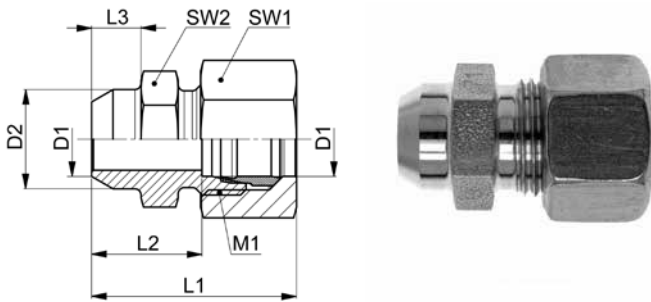

GAS-..L/S

Type -D1	Mat.-Nr.	PN	M1	D2	L1	L2	L3	SW1	SW2	g/Stk
GAS-06L	708.1400.060.20	500	12x1.5	10.0	29.0	14.0	7.0	14	12	25
GAS-08L	708.1400.080.20	500	14x1.5	12.0	31.0	16.0	8.0	17	14	36
GAS-10L	708.1400.100.20	500	16x1.5	14.0	33.0	18.0	8.0	19	17	47
GAS-12L	708.1400.120.20	400	18x1.5	16.0	33.0	18.0	8.0	22	19	55
GAS-15L	708.1400.150.20	400	22x1.5	19.0	37.0	22.0	10.0	27	22	90
GAS-18L	708.1400.180.20	400	26x1.5	22.0	40.0	23.5	10.0	32	27	130
GAS-22L	708.1400.220.20	250	30x2.0	27.0	45.0	28.5	12.0	36	32	190
GAS-28L	708.1400.280.20	250	36x2.0	32.0	47.0	30.5	12.0	41	41	270
GAS-35L	708.1400.350.20	250	45x2.0	40.0	54.0	32.5	14.0	50	46	395
GAS-42L	708.1400.420.20	250	52x2.0	46.0	58.0	35.0	16.0	60	55	585
GAS-06S	708.1400.060.30	800	14x1.5	11.0	34.0	19.0	7.0	17	14	38
GAS-08S	708.1400.080.30	800	16x1.5	13.0	36.0	21.0	8.0	19	17	54
GAS-10S	708.1400.100.30	800	18x1.5	15.0	39.0	22.5	8.0	22	19	70
GAS-12S	708.1400.120.30	630	20x1.5	17.0	41.0	24.5	10.0	24	22	125
GAS-14S	708.1400.140.30	630	22x1.5	19.0	45.0	27.0	10.0	27	24	140
GAS-16S	708.1400.160.30	630	24x1.5	21.0	45.0	26.5	10.0	30	27	156
GAS-20S	708.1400.200.30	420	30x2.0	26.0	51.0	29.5	12.0	36	32	240
GAS-25S	708.1400.250.30	420	36x2.0	31.0	56.0	32.0	12.0	46	41	460
GAS-30S	708.1400.300.30	420	42x2.0	36.0	62.0	35.5	14.0	50	46	555
GAS-38S	708.1400.380.30	420	52x2.0	44.0	69.0	38.0	16.0	60	55	786

Baumaße sind Ungefährmaße bei angezogener Überwurfmutter.

Sizes are approximate dimensions at tightened nut.

Las medidas son aproximadas con la tuerca de unión apretada.

Nach dem Anschweißen die in der Montageanleitung angegebenen Stellen nochmals mit der ASW Fettpaste schmieren (Schneidring, Gewinde der Mutter).

After welding, coat the parts indicated in the assembly instructions with ASW grease (cutting ring, thread of nut).

Luego de soldar, aplique nuevamente la grasa ASW en las partes indicadas en las instrucciones de montaje (anillo cortante, roscas de tuercas).

ISO 8434-1-WDSC

D1=Rohr außen-Ø
M1=metrisches Anschlußgewinde

D1=tube outside diameter
M1=metric connecting thread

D1=Ø exterior del tubo
M1=rosca métrica conexión

Gerade Anschweißstutzen
Straight weld-on connectors
Cuerpos para soldar rectos

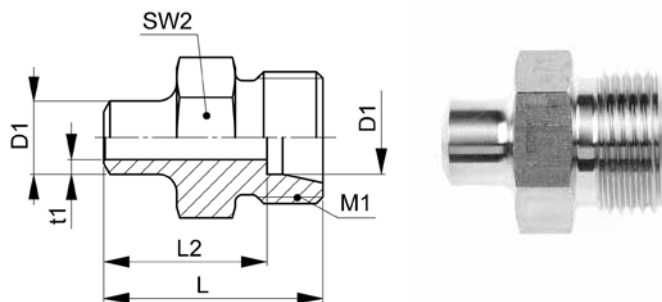

XGASK-..

Type-D1 x t1	Mat.-Nr.	PN	M1	L	L2	SW2	g/Stk
XGASK-10x2,0	706.1451.108.30	800	18x1.5	30.0	22.4	19	34
XGASK-12x2,5	706.1451.123.30	630	20x1.5	30.0	22.4	22	52
XGASK-16x3,0	706.1451.163.30	630	24x1.5	41.0	32.4	27	88
XGASK-20x4,0	706.1451.203.30	420	30x2.0	47.0	36.4	32	144
XGASK-25x5,0	706.1451.256.30	420	36x2.0	52.0	39.9	41	260
XGASK-30x6,0	706.1451.306.30	420	42x2.0	60.0	46.4	46	382
XGASK-38x7,0	706.1451.383.30	420	52x2.0	60.0	43.9	55	562

D1=Rohr außen-Ø
M1=metrisches Anschlußgewinde

D1=tube outside diameter
M1=metric connecting thread

D1=Ø exterior del tubo
M1=rosca métrica conexión

Gerade Anschweißverschraubungen

mit Schweißkegel und O-Ring

Straight weld-on fittings

with weldable cone and O-ring

Racores para soldar rectos

con cono para soldar y junta tórica

10

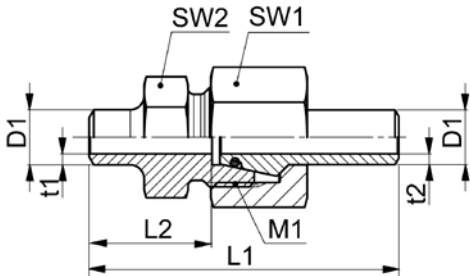

GASK-..

Type-D1 x t1	Mat.-Nr.	PN	M1	L1	L2	t2	SW1	SW2	g/Stk
GASK-10x2,0	708.1451.108.30	800	18x1.5	56.0	22.4	2.0	22	19	77
GASK-12x2,5	708.1451.123.30	630	20x1.5	56.0	22.4	2.5	24	22	108
GASK-16x3,0	708.1451.163.30	630	24x1.5	74.0	32.4	3.0	30	27	193
GASK-20x4,0	708.1451.203.30	420	30x2.0	84.0	36.4	4.0	36	32	322
GASK-25x5,0	708.1451.256.30	420	36x2.0	94.0	39.9	5.0	46	41	600
GASK-30x6,0	708.1451.306.30	420	42x2.0	104.0	46.4	6.0	50	46	802
GASK-38x7,0	708.1451.383.30	420	52x2.0	108.5	43.9	7.0	60	55	1214

Baumaße sind Ungefährmaße bei angezogener Überwurfmutter.

Nach dem Anschweißen die in der Montageanleitung angegebenen Stellen nochmals mit der ASW Fettpaste schmieren (Schneidring, Gewinde der Mutter).

O-Ringe aus FKM werden separat mitgeliefert, erst nach dem Schweißvorgang aufziehen.

Sizes are approximate dimensions at tightened nut.

After welding, coat the parts indicated in the assembly instructions with ASW grease (cutting ring, thread of nut).

FKM O-rings supplied separately, to be fitted after welding.

Las medidas son aproximadas con la tuerca de unión apretada.

Luego de soldar, aplique nuevamente la grasa ASW en las partes indicadas en las instrucciones de montaje (anillo cortante, roscas de tuercas).

Las juntas tóricas de FKM se suministran por separado; montarlas después de soldar.

D1=Rohr außen-Ø
M1=metrisches Anschlußgewinde

D1=tube outside diameter
M1=metric connecting thread

D1=Ø exterior del tubo
M1=rosca métrica conexión

Winkelanschweißstutzen
Elbow weld-on connectors
Cuerpos para soldar angulares

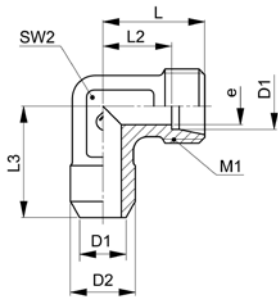

XWAS..L/S

Type -D1	Mat.-Nr.	PN	M1	D2	L	L2	L3	SW2	e	g/Stk
XWAS-06L	706.2400.060.20	500	12x1.5	10.0	19.0	12.0	19.0	12	4.0	22
XWAS-08L	706.2400.080.20	500	14x1.5	12.0	21.0	14.0	23.0	12	6.0	27
XWAS-10L	706.2400.100.20	500	16x1.5	14.0	22.0	15.0	24.0	14	8.0	36
XWAS-12L	706.2400.120.20	400	18x1.5	16.0	24.0	17.0	25.0	17	10.0	48
XWAS-15L	706.2400.150.20	400	22x1.5	19.0	28.0	21.0	30.0	19	12.0	83
XWAS-18L	706.2400.180.20	400	26x1.5	22.0	31.0	23.5	33.0	24	15.0	121
XWAS-22L	706.2400.220.20	250	30x2.0	27.0	35.0	27.5	37.0	27	19.0	164
XWAS-28L	706.2400.280.20	250	36x2.0	32.0	38.0	30.5	42.0	36	24.0	274
XWAS-06S	706.2400.060.30	800	14x1.5	11.0	23.0	16.0	23.0	12	4.0	37
XWAS-08S	706.2400.080.30	800	16x1.5	13.0	24.0	17.0	24.0	14	5.0	51
XWAS-10S	706.2400.100.30	800	18x1.5	15.0	25.0	17.5	25.0	17	7.0	62
XWAS-12S	706.2400.120.30	630	20x1.5	17.0	29.0	21.5	29.0	17	8.0	86
XWAS-14S	706.2400.140.30	630	22x1.5	19.0	30.0	22.0	30.0	19	10.0	103
XWAS-16S	706.2400.160.30	630	24x1.5	21.0	33.0	24.5	33.0	24	12.0	146
XWAS-20S	706.2400.200.30	420	30x2.0	26.0	37.0	26.5	37.0	27	16.0	206
XWAS-25S	706.2400.250.30	420	36x2.0	31.0	42.0	30.0	42.0	36	20.0	369

D1=Rohr außen-Ø
M1=metrisches Anschlußgewinde
e=kleinster Innen-Ø

D1=tube outside diameter
M1=metric connecting thread
e=minimum inside diameter

D1=Ø exterior del tubo
M1=rosca métrica conexión
e=Ø interior mínimo

Winkelanschweißverschraubungen

Elbow weld-on fittings

Racores para soldar angulares

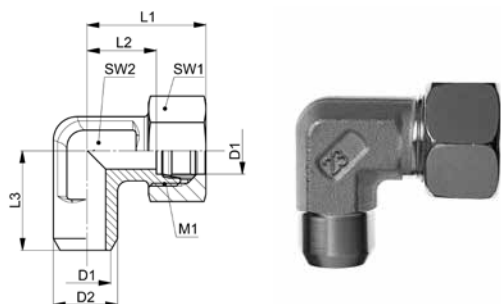

WAS-..L/S

Type -D1	Mat.-Nr.	PN	M1	D2	L1	L2	L3	SW1	SW2	g/Stk
WAS-06L	708.2400.060.20	500	12x1.5	10.0	27.0	12.0	19.0	14	12	34
WAS-08L	708.2400.080.20	500	14x1.5	12.0	29.0	14.0	23.0	17	12	47
WAS-10L	708.2400.100.20	500	16x1.5	14.0	30.5	15.0	24.0	19	14	61
WAS-12L	708.2400.120.20	400	18x1.5	16.0	32.5	17.0	25.0	22	17	78
WAS-15L	708.2400.150.20	400	22x1.5	19.0	37.0	21.0	30.0	27	19	127
WAS-18L	708.2400.180.20	400	26x1.5	22.0	40.5	23.5	33.0	32	24	204
WAS-22L	708.2400.220.20	250	30x2.0	27.0	44.5	27.5	37.0	36	27	261
WAS-28L	708.2400.280.20	250	36x2.0	32.0	47.5	30.5	42.0	41	36	382
WAS-06S	708.2400.060.30	800	14x1.5	11.0	31.0	16.0	23.0	17	12	54
WAS-08S	708.2400.080.30	800	16x1.5	13.0	32.0	17.0	24.0	19	14	71
WAS-10S	708.2400.100.30	800	18x1.5	15.0	34.5	17.5	25.0	22	17	96
WAS-12S	708.2400.120.30	630	20x1.5	17.0	38.5	21.5	29.0	24	17	123
WAS-14S	708.2400.140.30	630	22x1.5	19.0	40.5	22.0	30.0	27	19	154
WAS-16S	708.2400.160.30	630	24x1.5	21.0	44.0	24.5	33.0	30	24	230
WAS-20S	708.2400.200.30	420	30x2.0	26.0	49.5	26.5	37.0	36	27	327
WAS-25S	708.2400.250.30	420	36x2.0	31.0	55.5	30.0	42.0	46	36	589

Baumaße sind Ungefährmaße bei angezogener Überwurfmutter.

Sizes are approximate dimensions at tightened nut.

Las medidas son aproximadas con la tuerca de unión apretada.

Nach dem Anschweißen die in der Montageanleitung angegebenen Stellen nochmals mit der ASW Fettpaste schmieren (Schneidring, Gewinde der Mutter).

After welding, coat the parts indicated in the assembly instructions with ASW grease (cutting ring, thread of nut).

Luego de soldar, aplique nuevamente la grasa ASW en las partes indicadas en las instrucciones de montaje (anillo cortante, roscas de tuercas).

D1=Rohr außen-Ø
M1=metrisches Anschlußgewinde

D1=tube outside diameter
M1=metric connecting thread

D1=Ø exterior del tubo
M1=rosca métrica conexión

Einschweiß-Schottstutzen

Weld-in bulkhead connectors

Cuerpos de paso de mamparo para soldar

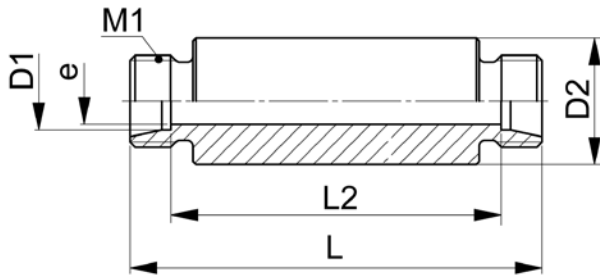

XESV-..L/S

Type -D1	Mat.-Nr.	PN	M1	D2	L	L2	e	g/Stk
XESV-06L	706.1452.060.20	500	12x1.5	18.0	70.0	56.0	4.0	105
XESV-08L	706.1452.080.20	500	14x1.5	20.0	70.0	56.0	6.0	125
XESV-10L	706.1452.100.20	500	16x1.5	22.0	72.0	58.0	8.0	146
XESV-12L	706.1452.120.20	400	18x1.5	25.0	72.0	58.0	10.0	182
XESV-15L	706.1452.150.20	400	22x1.5	28.0	84.0	70.0	12.0	271
XESV-18L	706.1452.180.20	400	26x1.5	32.0	84.0	69.0	15.0	342
XESV-22L	706.1452.220.20	250	30x2.0	36.0	88.0	73.0	19.0	411
XESV-28L	706.1452.280.20	250	36x2.0	40.0	88.0	73.0	24.0	463
XESV-35L	706.1452.350.20	250	45x2.0	50.0	92.0	71.0	30.0	740
XESV-42L	706.1452.420.20	250	52x2.0	60.0	92.0	70.0	36.0	1028
XESV-06S	706.1452.060.30	800	14x1.5	20.0	74.0	60.0	4.0	139
XESV-08S	706.1452.080.30	800	16x1.5	22.0	74.0	60.0	5.0	167
XESV-10S	706.1452.100.30	800	18x1.5	25.0	74.0	59.0	7.0	207
XESV-12S	706.1452.120.30	630	20x1.5	28.0	74.0	59.0	8.0	256
XESV-14S	706.1452.140.30	630	22x1.5	30.0	88.0	72.0	10.0	344
XESV-16S	706.1452.160.30	630	24x1.5	35.0	88.0	71.0	12.0	452
XESV-20S	706.1452.200.30	420	30x2.0	38.0	92.0	71.0	16.0	528
XESV-25S	706.1452.250.30	420	36x2.0	45.0	96.0	72.0	20.0	742
XESV-30S	706.1452.300.30	420	42x2.0	50.0	100.0	73.0	25.0	899
XESV-38S	706.1452.380.30	420	52x2.0	60.0	104.0	72.0	32.0	1285

ISO 8434-1-WDBHS

D1=Rohr außen-Ø
M1=metrisches Anschlußgewinde
e=kleinster Innen-Ø

D1=tube outside diameter
M1=metric connecting thread
e=minimum inside diameter

D1=Ø exterior del tubo
M1=rosca métrica conexión
e=Ø interior mínimo

Einschweiß-Schottverschraubungen

Weld-in bulkhead fittings

Racores de paso de mamparo para soldar

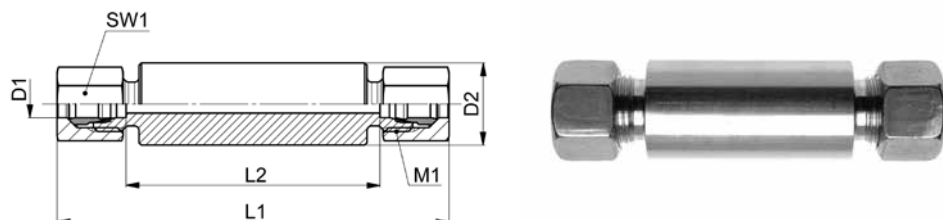

ESV-..L/S

Type -D1	Mat.-Nr.	PN	M1	D2	L1	L2	SW1	g/Stk
ESV-06L	708.1452.060.20	500	12x1.5	18.0	86.0	56.0	14	127
ESV-08L	708.1452.080.20	500	14x1.5	20.0	86.0	56.0	17	155
ESV-10L	708.1452.100.20	500	16x1.5	22.0	88.0	58.0	19	184
ESV-12L	708.1452.120.20	400	18x1.5	25.0	88.0	58.0	22	236
ESV-15L	708.1452.150.20	400	22x1.5	28.0	100.0	70.0	27	360
ESV-18L	708.1452.180.20	400	26x1.5	32.0	102.0	69.0	32	480
ESV-22L	708.1452.220.20	250	30x2.0	36.0	106.0	73.0	36	590
ESV-28L	708.1452.280.20	250	36x2.0	40.0	106.0	73.0	41	668
ESV-35L	708.1452.350.20	250	45x2.0	50.0	114.0	71.0	50	1065
ESV-42L	708.1452.420.20	250	52x2.0	60.0	116.0	70.0	60	1530
ESV-06S	708.1452.060.30	800	14x1.5	20.0	90.0	60.0	17	177
ESV-08S	708.1452.080.30	800	16x1.5	22.0	90.0	60.0	19	210
ESV-10S	708.1452.100.30	800	18x1.5	25.0	92.0	59.0	22	272
ESV-12S	708.1452.120.30	630	20x1.5	28.0	92.0	59.0	24	333
ESV-14S	708.1452.140.30	630	22x1.5	30.0	108.0	72.0	27	454
ESV-16S	708.1452.160.30	630	24x1.5	35.0	108.0	71.0	30	590
ESV-20S	708.1452.200.30	420	30x2.0	38.0	114.0	71.0	36	748
ESV-25S	708.1452.250.30	420	36x2.0	45.0	120.0	72.0	46	1180
ESV-30S	708.1452.300.30	420	42x2.0	50.0	126.0	73.0	50	1390
ESV-38S	708.1452.380.30	420	52x2.0	60.0	134.0	72.0	60	2011

Baumaße sind Ungefährmaße bei angezogener Überwurfmutter.

Sizes are approximate dimensions at tightened nut.

Las medidas son aproximadas con la tuerca de unión apretada.

Nach dem Anschweißen die in der Montageanleitung angegebenen Stellen nochmals mit der ASW Fettpaste schmieren (Schneidring, Gewinde der Mutter).

After welding, coat the parts indicated in the assembly instructions with ASW grease (cutting ring, thread of nut).

Luego de soldar, aplique nuevamente la grasa ASW en las partes indicadas en las instrucciones de montaje (anillo cortante, roscas de tuercas).

ISO 8434-1-WDBHSC

D1=Rohr außen-Ø
M1=metrisches Anschlußgewinde

D1=tube outside diameter
M1=metric connecting thread

D1=Ø exterior del tubo
M1=rosca métrica conexión

Schweißkegel

mit O-Ring

Weldable cones

with O-ring

Conos para soldar

con junta tórica

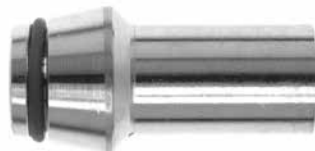
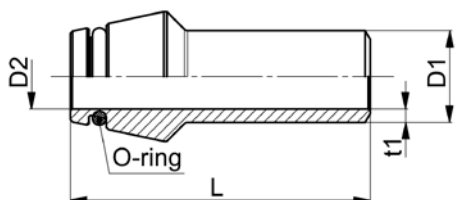

SKO

Type-D1 x t1	Mat.-Nr.	D2	L	O-Ring	g/Stk
◇ SKO-06x1,5	708.1453.061.30	3.0	31.0	4.0x1.5	6
◇ SKO-08x1,5	708.1453.081.30	5.0	31.0	6.0x1.5	6
◇ SKO-08x2,0	708.1453.082.30	4.0	31.0	6.0x1.5	10
◇ SKO-10x1,5	708.1453.105.30	7.0	32.5	7.5x1.5	12
◇ SKO-10x2,0	708.1453.108.30	6.0	32.5	7.5x1.5	14
◇ SKO-12x1,5	708.1453.122.30	9.0	32.5	9.0x1.5	16
◇ SKO-12x2,0	708.1453.125.30	8.0	32.5	9.0x1.5	18
◇ SKO-12x2,5	708.1453.123.30	7.0	32.5	9.0x1.5	22
◇ SKO-12x3,0	708.1453.124.30	6.0	32.5	9.0x1.5	24
◇ SKO-14x2,0	708.1453.141.30	10.0	40.0	10.0x2.0	24
◇ SKO-14x3,0	708.1453.142.30	8.0	40.0	10.0x2.0	34
◇ SKO-15x2,0	708.1453.151.30	11.0	36.0	12.0x2.0	24
◇ SKO-15x2,5	708.1453.152.30	10.0	36.0	12.0x2.0	30
◇ SKO-16x2,0	708.1453.161.30	12.0	39.0	12.0x2.0	30
◇ SKO-16x2,5	708.1453.162.30	11.0	39.0	12.0x2.0	36
◇ SKO-16x3,0	708.1453.163.30	10.0	39.0	12.0x2.0	40
• SKO-18x1,5	708.1453.181.30	15.0	36.0	15.0x2.0	24
• SKO-18x2,0	708.1453.182.30	14.0	36.0	15.0x2.0	31
◇ SKO-18x2,5	708.1453.183.30	13.0	36.0	15.0x2.0	38
◇ SKO-20x2,0	708.1453.204.30	16.0	44.5	16.3x2.4	44
◇ SKO-20x2,5	708.1453.201.30	15.0	44.5	16.3x2.4	54
◇ SKO-20x3,0	708.1453.202.30	14.0	44.5	16.3x2.4	62
◇ SKO-20x3,5	708.1453.205.30	13.0	44.5	16.3x2.4	70
◇ SKO-20x4,0	708.1453.203.30	12.0	44.5	16.3x2.4	76
◇ SKO-22x2,0	708.1453.221.30	18.0	38.5	20.0x2.0	40
◇ SKO-22x2,5	708.1453.223.30	17.0	38.5	20.0x2.0	62
◇ SKO-25x3,0	708.1453.253.30	19.0	49.5	20.3x2.4	88
◇ SKO-25x3,5	708.1453.258.30	18.0	49.5	20.3x2.4	99
◇ SKO-25x4,0	708.1453.255.30	18.0	49.5	20.3x2.4	110
◇ SKO-25x5,0	708.1453.256.30	15.0	49.5	20.3x2.4	130
◇ SKO-28x2,5	708.1453.281.30	23.0	41.5	26.0x2.0	70
◇ SKO-28x3,0	708.1453.282.30	22.0	41.5	26.0x2.0	80

Fortsetzung nächste Seite

Continued on next page

Continuación página próxima

D1=Rohr außen-Ø
 •=abweichende Form
 ◇=entspricht Reihe nach ISO 8434-1

D1=tube outside diameter
 •=different form
 ◇=according to series ISO 8434-1

D1=Ø exterior del tubo
 •=forma diferente
 ◇=según serie ISO 8434-1

Schweißkegel

mit O-Ring

Weldable cones

with O-ring

Conos para soldar

con junta tórica

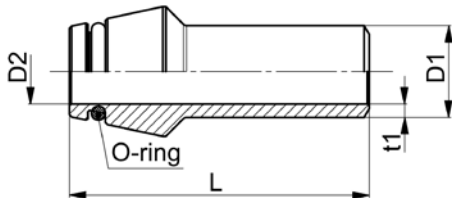

SKO

Type-D1 x t1	Mat.-Nr.	D2	L	O-Ring	g/Stk
◇ SKO-30x3,0	708.1453.301.30	24.0	52.0	25.3x2.4	114
SKO-30x4,0	708.1453.302.30	22.0	52.0	25.3x2.4	142
SKO-30x5,0	708.1453.304.30	20.0	52.0	25.3x2.4	168
SKO-30x6,0	708.1453.306.30	18.0	52.0	25.3x2.4	192
◇ SKO-35x3,0	708.1453.351.30	29.0	47.0	32.0x2.5	123
SKO-35x3,5	708.1453.352.30	28.0	47.0	32.0x2.5	138
SKO-35x4,0	708.1453.353.30	27.0	47.0	32.0x2.5	152
◇ SKO-38x3,0	708.1453.384.30	32.0	56.5	33.3x2.4	160
SKO-38x4,0	708.1453.381.30	30.0	56.5	33.3x2.4	200
SKO-38x5,0	708.1453.385.30	28.0	56.5	33.3x2.4	242
SKO-38x6,0	708.1453.382.30	26.0	56.5	33.3x2.4	276
◇ SKO-42x3,0	708.1453.993.30	36.0	47.0	38.0x2.5	150
SKO-42x4,0	708.1453.994.30	34.0	47.0	38.0x2.5	188

O-Ringe aus FKM werden separat mitgeliefert, erst nach dem Schweißvorgang aufziehen.

FKM O-rings supplied seperately, to be fitted after welding.

Las juntas tóricas de FKM se suministran por separado; montarlas después de soldar.

passend in 24°-Innenkonus (Bohrungsform W DIN 3861)

fitting type 24° inside tapers (bore type W DIN 3861)

encaja en cono interior de 24° (forma de taladro W DIN 3861)

ISO 8434-1-WDNP

D1=Rohr außen-Ø
 •=abweichende Form
 ◇=entspricht Reihe nach ISO 8434-1

D1=tube outside diameter
 •=different form
 ◇=according to series ISO 8434-1

D1=Ø exterior del tubo
 •=forma diferente
 ◇=según serie ISO 8434-1

Reduzierschweißkegel

mit O-Ring

Weldable reducing cones

with O-ring

Conos de reducción para soldar

con junta tórica

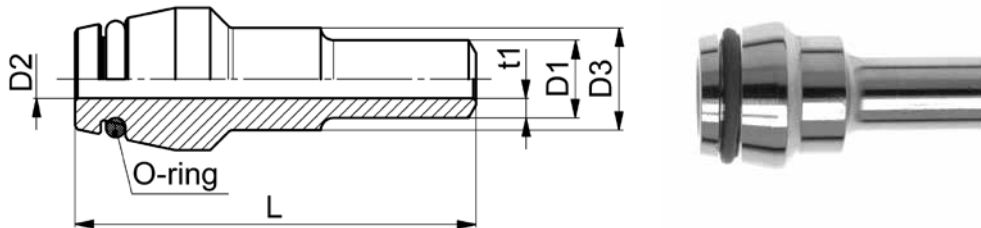

SKR

Type-D3 / D1 x t1	Mat.-Nr.	D2	L	O-Ring	g/Stk
SKR-16/10x1,5	708.1454.471.31	7.0	38.5	12.0x2.0	38
SKR-16/10x2,0	708.1454.472.31	6.0	38.5	12.0x2.0	34
SKR-16/12x2,5	708.1454.483.31	7.0	38.5	12.0x2.0	42
SKR-20/16x2,0	708.1454.686.31	12.0	44.0	16.3x2.4	74
SKR-20/16x2,5	708.1454.687.31	11.0	44.0	16.3x2.4	76
SKR-20/16x3,0	708.1454.688.31	10.0	44.0	16.3x2.4	78
SKR-25/16x2,5	708.1454.802.31	11.0	49.0	20.3x2.4	100
SKR-25/20x2,5	708.1454.822.31	15.0	49.0	20.3x2.4	104
SKR-25/20x3,0	708.1454.823.31	14.0	49.0	20.3x2.4	108
SKR-30/20x3,0	708.1454.930.31	14.0	51.5	25.3x2.4	169
SKR-30/25x3,0	708.1454.931.31	19.0	51.5	25.3x2.4	136
SKR-30/25x4,0	708.1454.932.31	17.0	51.5	25.3x2.4	166
SKR-38/16x2,0	708.1454.958.31	12.0	56.0	33.3x2.4	279
SKR-38/30x4,0	708.1454.974.31	22.0	56.0	33.3x2.4	286

O-Ringe aus FKM werden separat mitgeliefert, erst nach Schweißvorgang aufziehen.

FKM O-rings supplied separately, to be fitted after welding.

Las juntas tóricas de FKM se suministran por separado; montarlas después del proceso de soldado.

passend in 24°-Innenkonus (Bohrungsform W DIN 3861)

fitting type 24° inside tapers (bore type W DIN 3861)

encaja en cono interior de 24° (forma de taladro W DIN 3861)

ISO 8434-1-WDRDNP

Verstärkungshülsen

für dünnwandige Rohre

Reinforcing sleeves

for thin-walled tubes

Manguitos de refuerzo

para tubos de pared delgada

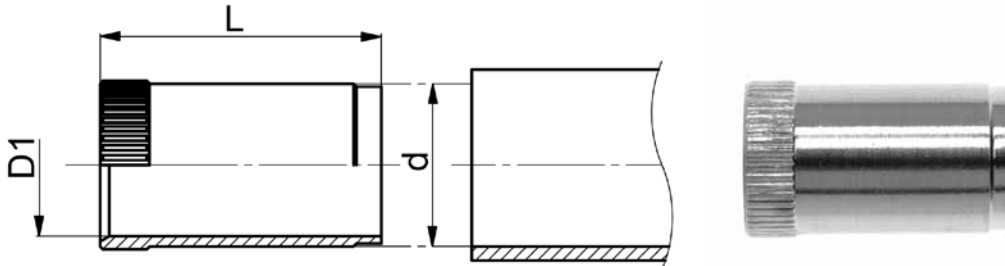

VHS

Type -d	Mat.-Nr.	D1	L	g/Stk
VHS-04	706.0030.059	2.5	15.5	1
VHS-05	706.0030.056	3.5	15.5	1
VHS-06	706.0030.080	4.5	15.5	1
VHS-07	706.0030.105	5.5	17.0	2
VHS-08	706.0030.103	6.5	17.0	2
VHS-09	706.0030.122	7.5	17.0	2
VHS-10	706.0030.121	8.5	17.0	2
VHS-11	706.0030.144	9.5	18.0	3
VHS-12	706.0030.154	10.0	18.0	4
VHS-13	706.0030.153	11.5	18.0	4
VHS-14	706.0030.165	12.0	18.0	5
VHS-15	706.0030.181	13.0	18.0	5
VHS-16	706.0030.185	14.0	22.0	6
VHS-17	706.0030.207	15.0	22.0	7
VHS-18	706.0030.206	16.0	22.0	8
VHS-19	706.0030.225	17.0	18.0	8
VHS-20	706.0030.224	18.0	18.0	8
VHS-21	706.0030.210	19.0	21.5	9
VHS-22	706.0030.252	20.0	24.0	10
VHS-24	706.0030.285	22.0	18.0	11
VHS-25	706.0030.284	23.0	18.0	11
VHS-31	706.0030.355	28.5	18.0	18
VHS-32	706.0030.320	29.5	23.0	18
VHS-33	706.0030.354	30.0	23.0	21
VHS-38	706.0030.996	35.5	24.0	25

Montage:

Hülse bis zum Rändelrand in das Rohr einstecken. Mit einem Hammer (Kunststoff oder Hartgummi) die Hülse ganz einschlagen. Hierbei wird der Rändelhals in die Innenwand des Rohres gepresst und sichert die Hülse gegen Verschieben oder Herausfallen.

Hinweise, für welche Rohre der Einsatz von Verstärkungshülsen empfohlen wird, finden Sie in Kapitel i unter "Empfehlungen für Edelstahlrohre".

Assembly:

Insert sleeve into tube up to the knurled edge. Use a hammer (plastic or hard rubber) to drive in the sleeve all the way. This will cause the knurled neck to be pressed into the inner wall of the tube and will secure the neck against being dislocated or falling out.

Information on which tube is recommended for use with reinforcing sleeves can be found in Section i under "Recommendations for stainless steel tubes".

Montaje:

Introducir el casquillo en el tubo hasta el borde moleteado. Golpear completamente el casquillo utilizando un martillo (de plástico o goma dura). De este modo se presionará el cuello moleteado en la pared interior del tubo y se asegurará el casquillo contra el movimiento o la caída.

Encontrará indicaciones sobre los tubos recomendados para el uso de casquillos reforzados en el Capítulo i, bajo "Recomendación para tubos en acero inoxidable".

Gewinde-Reduzierstutzen

Abdichtung durch Dichtkante Form B nach DIN 3852-2

Reducing adaptors

sealing edge form B acc. DIN 3852-2

Racores de reducción roscados

cierre hermético mediante borde de obturación forma B según DIN 3852-2

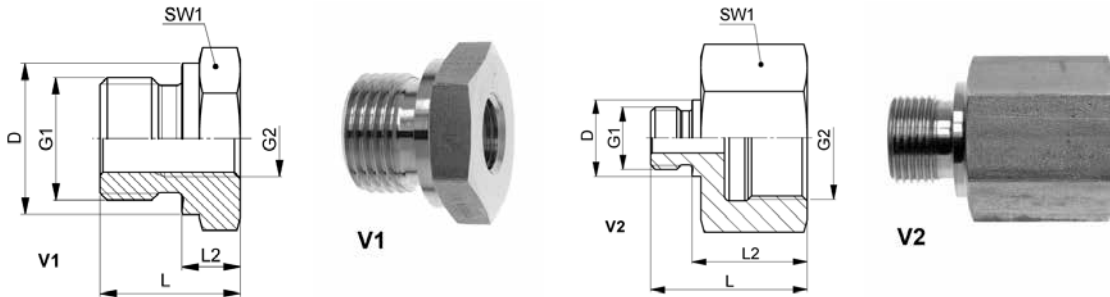

RS-..

Type-G1 /G2	Mat.-Nr.	PN	D	G1	G2	L	L2	SW1	Vers.	g/Stk
G1=Rohrgewinde (zylindrisch)		G1=BSP thread (parallel)		G1=Rosca de conexión (cilíndrica)						
G2=Rohrgewinde (zylindrisch)		G2=BSP thread (parallel)		G2=Rosca de conexión (cilíndrica)						
RS-1.8/1.4	706.0411.044	800	14.0	1/8	1/4	31.0	23.0	19	V2	30
RS-1.8/3.8	706.0411.046	800	14.0	1/8	3/8	32.0	24.0	24	V2	65
RS-1.4/1.8	706.0411.102	800	18.0	1/4	1/8	29.0	17.0	19	V2	38
RS-1.4/3.8	706.0411.106	800	18.0	1/4	3/8	36.0	24.0	24	V2	68
RS-1.4/1.2	706.0411.108	800	18.0	1/4	1/2	40.0	28.0	27	V2	80
RS-1.4/3.4	706.0411.110	800	18.0	1/4	3/4	43.0	31.0	36	V2	175
RS-3.8/1.8	706.0411.162	800	22.0	3/8	1/8	22.5	10.5	22	V1	40
RS-3.8/1.4	706.0411.164	800	22.0	3/8	1/4	36.0	24.0	22	V2	70
RS-3.8/1.2	706.0411.168	800	22.0	3/8	1/2	41.0	29.0	27	V2	95
RS-3.8/3.4	706.0411.170	800	22.0	3/8	3/4	44.0	32.0	36	V2	185
RS-1.2/1.8	706.0411.221	800	26.0	1/2	1/8	24.0	10.0	27	V1	65
RS-1.2/1.4	706.0411.224	800	26.0	1/2	1/4	24.0	10.0	27	V1	57
RS-1.2/3.8	706.0411.226	800	26.0	1/2	3/8	37.0	23.0	27	V2	100
RS-1.2/3.4	706.0411.232	800	26.0	1/2	3/4	46.0	32.0	36	V2	186
RS-1.2/1.1	706.0411.236	630	26.0	1/2	1	49.0	35.0	41	V2	220
RS-1.2/5.4	706.0411.237	420	26.0	1/2	1 1/4	53.0	39.0	55	V2	487
RS-3.4/1.4	706.0411.284	800	32.0	3/4	1/4	26.0	10.0	32	V1	105
RS-3.4/3.8	706.0411.286	800	32.0	3/4	3/8	26.0	10.0	32	V1	94
RS-3.4/1.2	706.0411.288	800	32.0	3/4	1/2	43.0	27.0	32	V2	145
RS-3.4/1.1	706.0411.296	630	32.0	3/4	1	51.0	35.0	41	V2	240
RS-3.4/5.4	706.0411.297	420	32.0	3/4	1 1/4	55.0	39.0	55	V2	525
RS-3.4/3.2	706.0411.298	420	32.0	3/4	1 1/2	57.0	41.0	60	V2	620
RS-1.1/1.4	706.0411.406	630	39.0	1	1/4	29.0	11.0	41	V1	195
RS-1.1/3.8	706.0411.407	630	39.0	1	3/8	29.0	11.0	41	V1	177
RS-1.1/1.2	706.0411.408	630	39.0	1	1/2	29.0	11.0	41	V1	155
RS-1.1/3.4	706.0411.412	630	39.0	1	3/4	49.0	31.0	41	V2	275
RS-1.1/5.4	706.0411.416	420	39.0	1	1 1/4	57.0	39.0	55	V2	520
RS-1.1/3.2	706.0411.417	420	39.0	1	1 1/2	59.0	41.0	60	V2	600

Fortsetzung auf nächster Seite

To be continued on next page

Continuación próxima página

Gewinde-Reduzierstutzen

Abdichtung durch Dichtkante Form B nach DIN 3852-2

Reducing adaptors

sealing edge form B acc. DIN 3852-2

Racores de reducción roscados

cierre hermético mediante borde de obturación forma B según DIN 3852-2

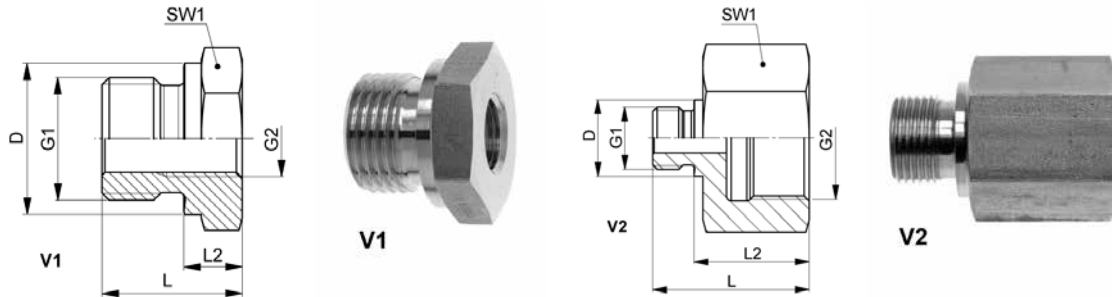

RS..

Type-G1 /G2	Mat.-Nr.	PN	D	G1	G2	L	L2	SW1	Vers.	g/Stk
G1=Rohrgewinde (zylindrisch)		G1=BSP thread (parallel)				G1=Rosca de conexión (cilíndrica)				
G2=Rohrgewinde (zylindrisch)		G2=BSP thread (parallel)				G2=Rosca de conexión (cilíndrica)				
RS-5.4/1.2	706.0411.488	420	49.0	1 1/4	1/2	32.0	12.0	50	V1	320
RS-5.4/3.4	706.0411.490	420	49.0	1 1/4	3/4	32.0	12.0	50	V1	264
RS-5.4/1.1	706.0411.487	420	49.0	1 1/4	1	52.0	32.0	50	V2	467
RS-5.4/3.2	706.0411.489	420	49.0	1 1/4	1 1/2	60.0	40.0	60	V2	640
RS-3.2/1.2	706.0411.511	420	55.0	1 1/2	1/2	36.0	14.0	55	V1	486
RS-3.2/3.4	706.0411.513	420	55.0	1 1/2	3/4	36.0	14.0	55	V1	430
RS-3.2/1.1	706.0411.512	420	55.0	1 1/2	1	36.0	14.0	55	V1	346
RS-3.2/5.4	706.0411.514	420	55.0	1 1/2	1 1/4	58.0	36.0	55	V2	535
RS-4.2/1.1	706.0411.602	420	68.0	2	1	43.0	19.0	70	V1	881
RS-4.2/3.2	706.0411.617	420	68.0	2	1 1/2	43.0	19.0	70	V1	547

Gewinde-Reduzierstutzen

Abdichtung durch Profildichtring Form E nach ISO 1179-2

Reducing adaptors

profile sealing ring form E acc. ISO 1179-2

Racores de reducción roscados

cierre hermético mediante junta con perfil forma E según ISO 1179-2

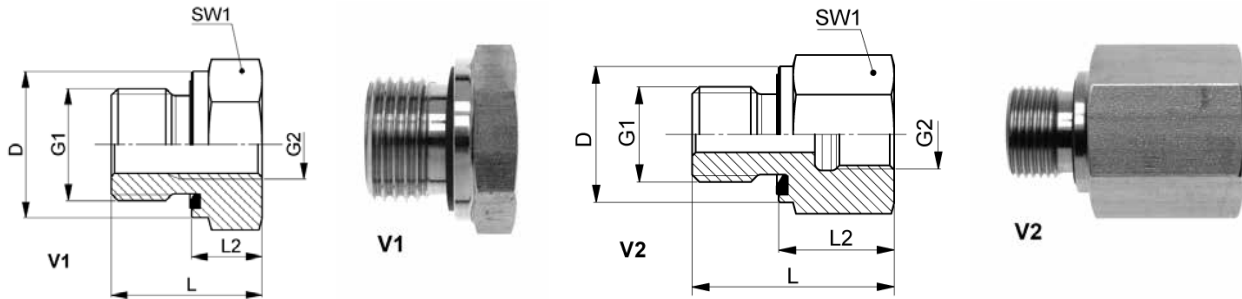

RS..WD

Type-G1 /G2	Mat.-Nr.	PN	D	G1	G2	L	L2	SW1	Vers.	g/Stk
G1=Rohrgewinde (zylindrisch)		G1=BSP thread (parallel)								
G2=Rohrgewinde (zylindrisch)		G2=BSP thread (parallel)								
									G1=Rosca de conexión (cilíndrica)	
									G2=Rosca de conexión (cilíndrica)	
RS-1.8/1.4 WD	708.0416.044	800	14.0	1/8	1/4	31.0	23.0	19	V2	30
RS-1.8/3.8 WD	708.0416.046	800	14.0	1/8	3/8	32.0	24.0	24	V2	65
RS-1.4/1.8 WD	708.0416.102	800	19.0	1/4	1/8	29.0	17.0	19	V2	38
RS-1.4/3.8 WD	708.0416.106	800	19.0	1/4	3/8	36.0	24.0	24	V2	68
RS-1.4/1.2 WD	708.0416.108	800	19.0	1/4	1/2	40.0	28.0	27	V2	80
RS-1.4/3.4 WD	708.0416.110	800	19.0	1/4	3/4	43.0	31.0	36	V2	175
RS-3.8/1.8 WD	708.0416.162	800	22.0	3/8	1/8	22.5	10.5	22	V1	40
RS-3.8/1.4 WD	708.0416.164	800	22.0	3/8	1/4	36.0	24.0	22	V2	70
RS-3.8/1.2 WD	708.0416.168	800	22.0	3/8	1/2	41.0	29.0	27	V2	95
RS-3.8/3.4 WD	708.0416.170	800	22.0	3/8	3/4	44.0	32.0	36	V2	185
RS-1.2/1.8 WD	708.0416.221	800	27.0	1/2	1/8	24.0	10.0	27	V1	65
RS-1.2/1.4 WD	708.0416.224	800	27.0	1/2	1/4	24.0	10.0	27	V1	57
RS-1.2/3.8 WD	708.0416.226	800	27.0	1/2	3/8	37.0	23.0	27	V2	100
RS-1.2/3.4 WD	708.0416.232	800	27.0	1/2	3/4	46.0	32.0	36	V2	186
RS-1.2/1.1 WD	708.0416.236	630	27.0	1/2	1	49.0	35.0	41	V2	220
RS-1.2/5.4 WD	708.0416.237	420	27.0	1/2	1 1/4	53.0	39.0	55	V2	487
RS-3.4/1.4 WD	708.0416.284	800	32.0	3/4	1/4	26.0	10.0	32	V1	105
RS-3.4/3.8 WD	708.0416.286	800	32.0	3/4	3/8	26.0	10.0	32	V1	94
RS-3.4/1.2 WD	708.0416.288	800	32.0	3/4	1/2	43.0	27.0	32	V2	145
RS-3.4/1.1 WD	708.0416.296	630	32.0	3/4	1	51.0	35.0	41	V2	240
RS-3.4/5.4 WD	708.0416.297	420	32.0	3/4	1 1/4	55.0	39.0	55	V2	525
RS-3.4/3.2 WD	708.0416.298	420	32.0	3/4	1 1/2	57.0	41.0	60	V2	620
RS-1.1/1.4 WD	708.0416.406	630	40.0	1	1/4	29.0	11.0	41	V1	195
RS-1.1/3.8 WD	708.0416.407	630	40.0	1	3/8	29.0	11.0	41	V1	177
RS-1.1/1.2 WD	708.0416.408	630	40.0	1	1/2	29.0	11.0	41	V1	155
RS-1.1/3.4 WD	708.0416.412	630	40.0	1	3/4	49.0	31.0	41	V2	275
RS-1.1/5.4 WD	708.0416.416	420	40.0	1	1 1/4	57.0	39.0	55	V2	520
RS-1.1/3.2 WD	708.0416.417	420	40.0	1	1 1/2	59.0	41.0	60	V2	600

Fortsetzung auf nächster Seite

To be continued on next page

Continuación próxima página

Gewinde-Reduzierstutzen

Abdichtung durch Profildichtring Form E nach ISO 1179-2

Reducing adaptors

profile sealing ring form E acc. ISO 1179-2

Racores de reducción roscados

cierre hermético mediante junta con perfil forma E según ISO 1179-2

10

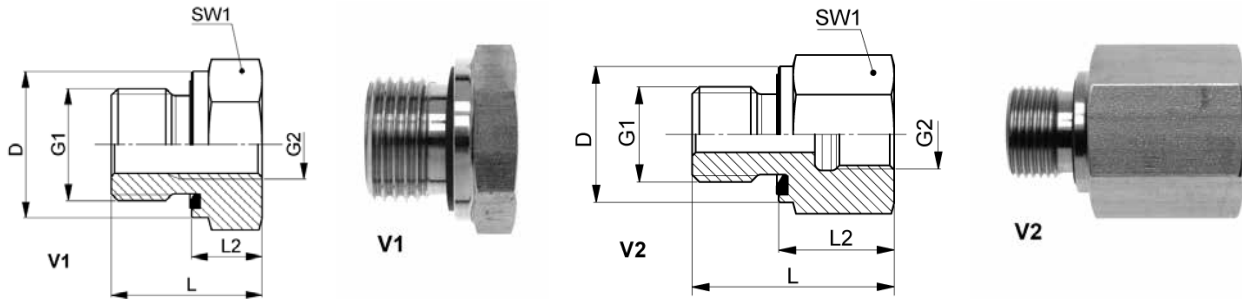

RS..WD

Type-G1 /G2	Mat.-Nr.	PN	D	G1	G2	L	L2	SW1	Vers.	g/Stk
G1=Rohrgewinde (zylindrisch)		G1=BSP thread (parallel)						G1=Rosca de conexión (cilíndrica)		
G2=Rohrgewinde (zylindrisch)		G2=BSP thread (parallel)						G2=Rosca de conexión (cilíndrica)		
RS-5.4/1.2 WD	708.0416.488	420	50.0	1 1/4	1/2	32.0	12.0	50	V1	310
RS-5.4/3.4 WD	708.0416.490	420	50.0	1 1/4	3/4	32.0	12.0	50	V1	264
RS-5.4/1.1 WD	708.0416.487	420	50.0	1 1/4	1	52.0	32.0	50	V2	458
RS-5.4/3.2 WD	708.0416.489	420	50.0	1 1/4	1 1/2	60.0	40.0	60	V2	640
RS-3.2/1.2 WD	708.0416.511	420	55.0	1 1/2	1/2	36.0	14.0	55	V1	480
RS-3.2/3.4 WD	708.0416.513	420	55.0	1 1/2	3/4	36.0	14.0	55	V1	425
RS-3.2/1.1 WD	708.0416.512	420	55.0	1 1/2	1	36.0	14.0	55	V1	344
RS-3.2/5.4 WD	708.0416.514	420	55.0	1 1/2	1 1/4	58.0	36.0	55	V2	535

Dichtungsmaterial: FKM (andere Werkstoffe auf Anfrage)

Sealing material: FKM (other materials on request)

Material de junta tórica: FKM (otros materiales bajo demanda).

Verschlusschrauben

mit Innensechskant, DIN 908, Abdichtung durch Dichtkante Form B nach DIN 3852-2

Locking screws

with internal hexagon, DIN 908, sealing edge form B acc. DIN 3852-2

Tornillos de cierre

con hexágono interior, DIN 908, cierre hermético mediante borde de obturación forma B según DIN 3852-2

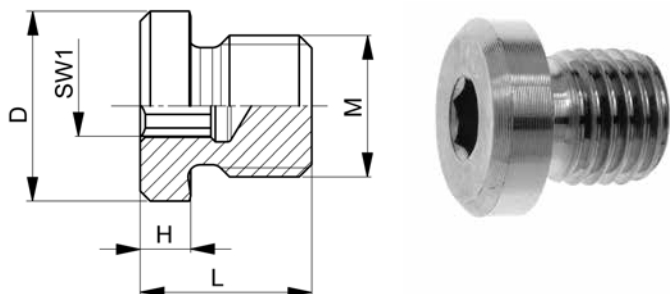

VSI..M

Type -M	Mat.-Nr.	PN	D	M	H	L	SW1	g/Stk
M=metrisches Gewinde (zylindrisch)		M=metric thread (parallel)				M=rosca métrica (cilíndrica)		
VSI-M 10x1,0	706.0723.150	800	14.0	10x1.0	4.0	12.0	5	6
VSI-M 12x1,5	706.0723.195	800	17.0	12x1.5	5.0	17.0	6	12
VSI-M 14x1,5	706.0723.225	800	19.0	14x1.5	5.0	17.0	6	20
VSI-M 16x1,5	706.0723.265	800	21.0	16x1.5	5.0	17.0	8	22
VSI-M 18x1,5	706.0723.305	800	23.0	18x1.5	5.0	17.0	8	32
VSI-M 20x1,5	706.0723.345	800	25.0	20x1.5	5.0	19.0	10	44
VSI-M 22x1,5	706.0723.375	800	27.0	22x1.5	5.0	19.0	10	50
VSI-M 26x1,5	706.0723.435	800	31.0	26x1.5	5.0	21.0	12	80
VSI-M 27x2,0	706.0723.400	800	32.0	27x2.0	5.0	21.0	12	80
VSI-M 33x2,0	706.0723.510	630	39.0	33x2.0	6.5	22.5	17	138
VSI-M 48x2,0	706.0723.748	420	55.0	48x2.0	6.5	22.5	24	210

Verschlusschrauben

mit Innensechskant, DIN 908, Abdichtung durch Profildichtring Form E nach ISO 1179-2

Locking screws

with internal hexagon, DIN 908, profile sealing ring form E acc. ISO 1179-2

Tornillos de cierre

con hexágono interior, DIN 908, cierre hermético mediante junta con perfil forma E según ISO 1179-2

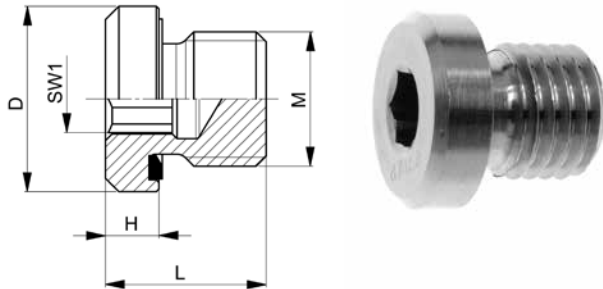

VSI-..M WD

Type-M	Mat.-Nr.	PN	D	M	H	L	SW1	g/Stk
M=metrisches Gewinde (zylindrisch)	M=metric thread (parallel)	M=rosca métrica (cilíndrica)						
VSI-M 10x1,0 WD	708.0724.150	800	14.0	10x1.0	4.0	12.0	5	6
VSI-M 12x1,5 WD	708.0724.195	800	17.0	12x1.5	5.0	17.0	6	12
VSI-M 14x1,5 WD	708.0724.225	800	19.0	14x1.5	5.0	17.0	6	20
VSI-M 16x1,5 WD	708.0724.265	800	22.0	16x1.5	5.0	17.0	8	22
VSI-M 18x1,5 WD	708.0724.305	800	24.0	18x1.5	5.0	17.0	8	32
VSI-M 20x1,5 WD	708.0724.345	800	26.0	20x1.5	5.0	19.0	10	44
VSI-M 22x1,5 WD	708.0724.375	800	27.0	22x1.5	5.0	19.0	10	50
VSI-M 26x1,5 WD	708.0724.435	800	32.0	26x1.5	5.0	21.0	12	80
VSI-M 27x2,0 WD	708.0724.400	630	32.0	27x2.0	5.0	21.0	12	80
VSI-M 33x2,0 WD	708.0724.510	630	40.0	33x2.0	6.5	22.5	17	138
VSI-M 42x2,0 WD	708.0724.642	420	50.0	42x2.0	6.5	22.5	22	208
VSI-M 48x2,0 WD	708.0724.748	420	55.0	48x2.0	6.5	22.5	24	210

Dichtungsmaterial: FKM (andere Werkstoffe auf Anfrage)

Sealing material: FKM (other materials on request)

Material de junta tórica: FKM (otros materiales bajo demanda).

Verschlusschrauben

mit Innensechskant, DIN 908, Abdichtung durch Dichtkante Form B nach DIN 3852-2

Locking screws

with internal hexagon, DIN 908, sealing edge form B acc. DIN 3852-2

Tornillos de cierre

con hexágono interior, DIN 908, cierre hermético mediante borde de obturación forma B según DIN 3852-2

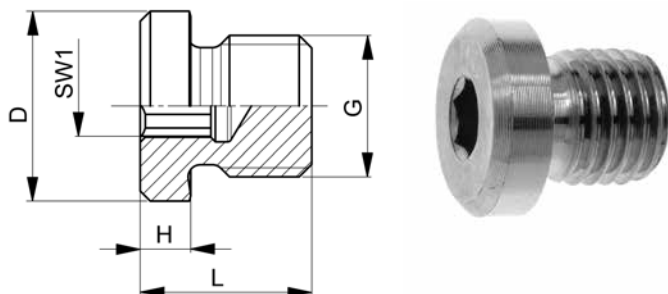

VSI..R

Type-G	Mat.-Nr.	PN	D	G	H	L	SW1	g/Stk
G=Rohrgewinde (zylindrisch)		G=BSP thread (parallel)				G=rosca de conexión (cilíndrica)		
VSI-R 1.8	706.0721.020	800	14.0	1/8	4.0	12.0	5	6
VSI-R 1.4	706.0721.040	800	18.0	1/4	5.0	17.0	6	18
VSI-R 3.8	706.0721.060	800	22.0	3/8	5.0	17.0	8	26
VSI-R 1.2	706.0721.080	800	26.0	1/2	5.0	19.0	10	44
VSI-R 3.4	706.0721.120	800	32.0	3/4	5.0	21.0	12	76
VSI-R 1.1	706.0721.160	630	39.0	1	6.5	22.5	17	126
VSI-R 5.4	706.0721.180	420	49.0	1 1/4	6.5	22.5	22	192
VSI-R 3.2	706.0721.200	420	55.0	1 1/2	6.5	22.5	24	268

Verschlusschrauben

mit Innensechskant, DIN 908, Abdichtung durch Profildichtring Form E nach ISO 1179-2

Locking screws

with internal hexagon, DIN 908, profile sealing ring form E acc. ISO 1179-2

Tornillos de cierre

con hexágono interior, DIN 908, cierre hermético mediante junta con perfil forma E según ISO 1179-2

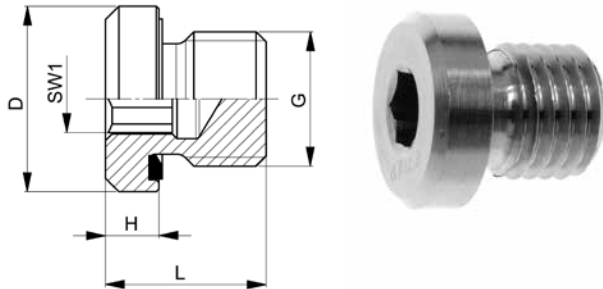

10

VSI..R WD

Type-G	Mat.-Nr.	PN	D	G	H	L	SW1	g/Stk
G=Rohrgewinde (zylindrisch)		G=BSP thread (parallel)				G=rosca de conexión (cilíndrica)		
VSI-R1.8 WD	708.0722.020	800	14.0	1/8	4.0	12.0	5	6
VSI-R1.4 WD	708.0722.040	800	19.0	1/4	5.0	17.0	6	16
VSI-R3.8 WD	708.0722.060	800	22.0	3/8	5.0	17.0	8	29
VSI-R1.2 WD	708.0722.080	800	27.0	1/2	5.0	19.0	10	42
VSI-R3.4 WD	708.0722.120	800	32.0	3/4	5.0	21.0	12	76
VSI-R1.1 WD	708.0722.160	630	40.0	1	6.5	22.5	17	130
VSI-R5.4 WD	708.0722.180	420	50.0	1 1/4	6.5	22.5	22	186
VSI-R3.2 WD	708.0722.200	420	55.0	1 1/2	6.5	22.5	24	256

Dichtungsmaterial: FKM (andere Werkstoffe auf Anfrage)

Sealing material: FKM (other materials on request)

Material de junta tórica: FKM (otros materiales bajo demanda).

Verschlussstopfen

metallisch dichtend

Blanking plugs

metal-metal sealing

Tapónes

cierre metal/metal

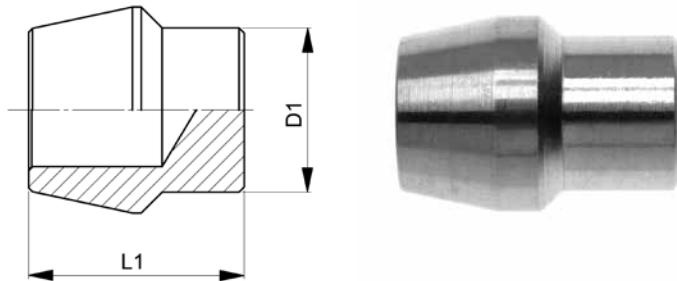

VOE-..L/S

Type-D1	Mat.-Nr.	PN	L	g/Stk
VOE-06L/S	706.0033.060.13	630	17.5	4
VOE-08L/S	706.0033.080.13	630	18.5	8
VOE-10L/S	706.0033.100.13	630	19.5	17
VOE-12L/S	706.0033.120.13	630	19.5	22
VOE-15L	706.0033.150.20	400	19.5	24
VOE-18L	706.0033.180.20	400	20.0	31
VOE-22L	706.0033.220.20	250	20.5	52
VOE-28L	706.0033.280.20	250	21.5	97
VOE-35L	706.0033.350.20	250	24.0	176
VOE-42L	706.0033.420.20	250	25.0	234
VOE-14S	706.0033.140.30	630	20.0	24
VOE-16S	706.0033.160.30	630	21.0	34
VOE-20S	706.0033.200.30	630	24.0	57
VOE-25S	706.0033.250.30	630	25.0	104
VOE-30S	706.0033.300.30	630	26.5	151
VOE-38S	706.0033.380.30	630	30.0	213

passend in 24°-Innenkonus
(Bohrungsform W DIN 3861)

fitting type 24° inside tapers
(bore type W DIN 3861)

encaja en cono interior de 24°
(forma de taladro W DIN 3861)

Verschlussstopfen

mit O-Ring

Blanking plugs

with O-ring

Tapón

con junta tórica

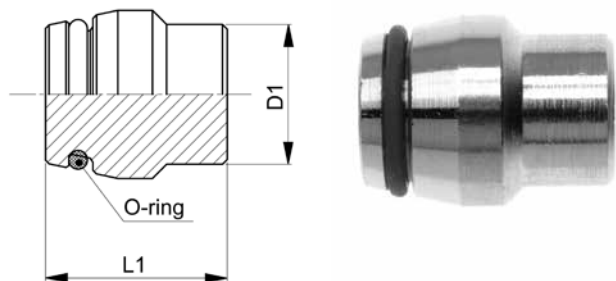

VME-..L/S

Type-D1	Mat.-Nr.	PN	L	O-Ring	g/Stk
VME-06L/S	708.0020.060.13	800	17.5	4.0x1.5	14
VME-08L/S	708.0020.080.13	800	18.5	6.0x1.5	17
VME-10L/S	708.0020.100.13	800	19.5	7.5x1.5	21
VME-12L/S	708.0020.120.13	630	19.5	9.0x1.5	25
VME-15L	708.0020.150.20	400	19.5	12.0x2.0	35
VME-18L	708.0020.180.20	400	20.0	15.0x2.0	45
VME-22L	708.0020.220.20	250	20.5	20.0x2.0	67
VME-28L	708.0020.280.20	250	21.5	26.0x2.0	100
VME-35L	708.0020.350.20	250	23.5	32.0x2.5	196
VME-42L	708.0020.420.20	250	25.0	38.0x2.5	257
VME-14S	708.0020.140.30	630	20.0	12.0x2.0	27
VME-16S	708.0020.160.30	630	21.0	12.0x2.0	37
VME-20S	708.0020.200.30	630	24.0	16.3x2.4	62
VME-25S	708.0020.250.30	420	25.0	20.3x2.4	108
VME-30S	708.0020.300.30	420	26.5	25.3x2.4	160
VME-38S	708.0020.380.30	420	30.0	33.3x2.4	231

passend in 24°-Innenkonus
(Bohrungsform W DIN 3861)

fitting type 24° inside tapers
(bore type W DIN 3861)

encaja en cono interior de 24°
(forma de taladro W DIN 3861)

Dichtungsmaterial: FKM (andere Werkstoffe auf
Anfrage)

Sealing material: FKM (other materials on
request)

Material de junta tórica: FKM (otros materiales
bajo demanda).

ISO 8434-1-PL

Überwurfmuttern

Nuts

Tuercas de unión

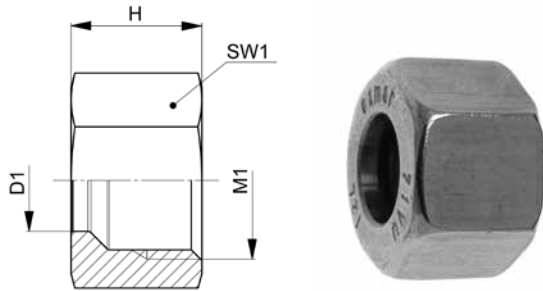

UEM-..L/S

Type -D1	Mat.-Nr.	PN	M1	H	SW1	g/Stk
M1=metrisches Gewinde (zylindrisch)	M1=metric thread (parallel)	M1=rosca métrica (cilindrica)				
UEM-04LL	706.0200.040.10	100	8x1.0	11.0	10	4
UEM-06LL	706.0200.060.10	100	10x1.0	11.5	12	5
UEM-08LL	706.0200.080.10	100	12x1.0	12.0	14	7
UEM-10LL	706.0200.100.10	100	14x1.0	12.5	17	11
UEM-12LL	706.0200.120.10	100	16x1.0	13.0	19	13
UEM-06L	706.0200.060.20	500	12x1.5	14.5	14	10
UEM-08L	706.0200.080.20	500	14x1.5	14.5	17	15
UEM-10L	706.0200.100.20	500	16x1.5	15.5	19	18
UEM-12L	706.0200.120.20	400	18x1.5	15.5	22	25
UEM-15L	706.0200.150.20	400	22x1.5	17.0	27	41
UEM-18L	706.0200.180.20	400	26x1.5	18.0	32	63
UEM-22L	706.0200.220.20	250	30x2.0	20.0	36	83
UEM-28L	706.0200.280.20	250	36x2.0	21.0	41	91
UEM-35L	706.0200.350.20	250	45x2.0	24.0	50	147
UEM-42L	706.0200.420.20	250	52x2.0	24.0	60	231
UEM-06S	706.0200.060.30	800	14x1.5	16.5	17	16
UEM-08S	706.0200.080.30	800	16x1.5	16.5	19	19
UEM-10S	706.0200.100.30	800	18x1.5	17.5	22	29
UEM-12S	706.0200.120.30	630	20x1.5	17.5	24	34
UEM-14S	706.0200.140.30	630	22x1.5	20.5	27	50
UEM-16S	706.0200.160.30	630	24x1.5	20.5	30	64
UEM-20S	706.0200.200.30	420	30x2.0	24.0	36	103
UEM-25S	706.0200.250.30	420	36x2.0	27.0	46	212
UEM-30S	706.0200.300.30	420	42x2.0	29.0	50	233
UEM-38S	706.0200.380.30	420	52x2.0	32.5	60	341

Überwurfmuttern auch innen versilbert erhältlich
Art. NC-UEM, siehe Kapitel 20.

Nuts also available inside silver-plated:
Art. NC-UEM, see chapter 20.

Tuercas de unión disponibles también con interior plateado:
Art. NC-UEM, véase capítulo 20.

ISO 8434-1-N

Schneidringe

nach DIN 3861

Cutting rings

according to DIN 3861

Anillos cortantes

según DIN 3861

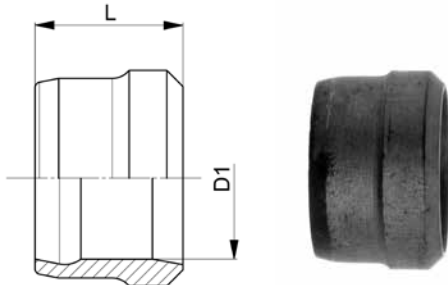

SR-..L/S

Type-D1	Mat.-Nr.	PN	L	g/Stk
SR-06L/S	706.0021.060.13	800	9.0	2
SR-08L/S	706.0021.080.13	800	9.0	2
SR-10L/S	706.0021.100.13	800	10.0	3
SR-12L/S	706.0021.120.13	630	10.0	3
SR-04LL	706.0021.040.10	100	6.0	1
SR-06LL	706.0021.060.10	100	7.0	1
SR-08LL	706.0021.080.10	100	7.0	1
SR-10LL	706.0021.100.10	100	7.0	1
SR-12LL	706.0021.120.10	100	7.5	2
SR-15L	706.0021.150.20	400	10.0	4
SR-18L	706.0021.180.20	400	10.0	5
SR-22L	706.0021.220.20	250	10.5	7
SR-28L	706.0021.280.20	250	10.5	8
SR-35L	706.0021.350.20	250	13.0	17
SR-42L	706.0021.420.20	250	13.5	22
SR-14S	706.0021.140.30	630	10.0	4
SR-16S	706.0021.160.30	630	10.5	5
SR-20S	706.0021.200.30	420	12.5	9
SR-25S	706.0021.250.30	420	12.5	12
SR-30S	706.0021.300.30	420	13.0	16
SR-38S	706.0021.380.30	420	13.5	23

ISO 8434-1-CR

D1=Rohr außen-Ø

D1=tube outside diameter

D1=Ø exterior del tubo

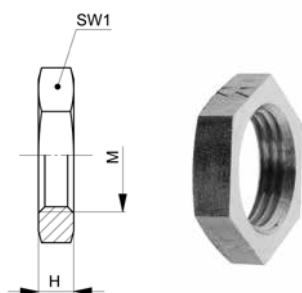
Kontermuttern
Counter nuts
Contratuercas

KM-..L/S

Type-D1	Mat.-Nr.	M	H	SW1	g/Stk
M=metrisches Gewinde (zylindrisch)	M=metric thread (parallel)	M=rosca métrica (cilindrica)			
KM-06S/08L	706.0063.225.13	14x1.5	6.0	19	7
KM-08S/10L	706.0063.265.13	16x1.5	6.0	22	10
KM-10S/12L	706.0063.305.13	18x1.5	6.0	24	12
KM-14S/15L	706.0063.375.13	22x1.5	7.0	30	24
KM-20S/22L	706.0063.470.13	30x2.0	8.0	41	52
KM-25S/28L	706.0063.560.13	36x2.0	9.0	46	64
KM-38S/42L	706.0063.652.13	52x2.0	10.0	65	130
KM-06L	706.0063.195.20	12x1.5	6.0	17	6
KM-18L	706.0063.435.20	26x1.5	8.0	36	36
KM-35L	706.0063.745.20	45x2.0	9.0	55	78
KM-12S	706.0063.345.30	20x1.5	7.0	27	21
KM-16S	706.0063.405.30	24x1.5	7.0	32	39
KM-30S	706.0063.642.30	42x2.0	9.0	50	78

ISO 8434-1-LN

Dichtringe

für Außengewinde von Schwenkverschraubungen

Seal rings

for external threads of banjo fittings

Anillos de obturación

para roscas exteriores de racores orientables

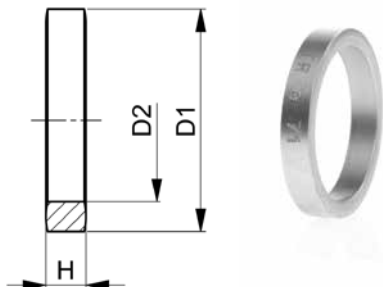

EDKR-..M/R

Type -M	Mat.-Nr.	D1	D2	H	g/Stk
M=metrisches Gewinde (zylindrisch)	M=metric thread (parallel)	M=rosca métrica (cilíndrica)			
EDKR-M 10x1,0/R 1.8	706.0126.150	14.0	10.0	2.5	1
EDKR-M 12x1,5/M 14x1,5/R 1.4	706.0126.225	18.0	14.0	3.0	2
EDKR-M 16x1,5/R 3.8	706.0126.265	21.0	17.0	3.0	2
EDKR-M 18x1,5	706.0126.305	23.0	18.0	3.0	3
EDKR-M 20x1,5/M 22x1,5/R 1.2	706.0126.375	27.0	22.0	4.5	5
EDKR-M 26x1,5/M 27x2,0/R 3.4	706.0126.440	32.0	27.0	3.5	4
EDKR-M 33x2,0/R 1.1	706.0126.510	39.0	33.5	3.5	5
EDKR-M 42x2,0/R 5.4	706.0126.642	49.0	42.0	3.5	9
EDKR-M 48x2,0/R 3.2	706.0126.748	55.0	48.0	3.5	11

Type -G	Mat.-Nr.	D1	D2	H	g/Stk
G=Rohrgewinde (zylindrisch)	G=BSP thread (parallel)	G=rosca de conexión (cilíndrica)			
EDKR-M 10x1,0/R 1.8	706.0126.150	14.0	10.0	2.5	1
EDKR-M 12x1,5/M 14x1,5/R 1.4	706.0126.225	18.0	14.0	3.0	2
EDKR-M 16x1,5/R 3.8	706.0126.265	21.0	17.0	3.0	2
EDKR-M 20x1,5/M 22x1,5/R 1.2	706.0126.375	27.0	22.0	4.5	5
EDKR-M 26x1,5/M 27x2,0/R 3.4	706.0126.440	32.0	27.0	3.5	4
EDKR-M 33x2,0/R 1.1	706.0126.510	39.0	33.5	3.5	5
EDKR-M 42x2,0/R 5.4	706.0126.642	49.0	42.0	3.5	9
EDKR-M 48x2,0/R 3.2	706.0126.748	55.0	48.0	3.5	11

M/G für Außengewinde nach ISO 228/1

M/G for male threads ISO 228/1

M/G para roscas exteriores ISO 228/1

Dichtkantenringe

für Innengewinde für Manometer-Verschraubungen

Seal edge rings

for internal threads for manometer fittings

Anillos con borde de obturación

para roscas interiores de racores manométricos

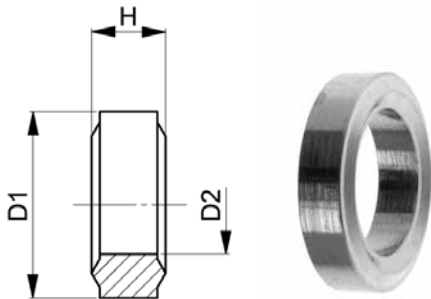

DKR-..R

Type -G	Mat.-Nr.	D1	D2	G	H	g/Stk
G=Rohrgewinde (zylindrisch)		G=BSP thread (parallel)		G=rosca de conexión (cilíndrica)		
DKR-R 1.4	706.0023.040	11.5	6.0	1/4	4.5	1
DKR-R 1.2	706.0023.080	18.5	12.0	1/2	5.0	4

für Innengewinde ISO 228/1

for internal threads ISO 228/1

para roscas interiores ISO 228/1

Profildichtringe FKM

für Einschraubgewinde, Abdichtung Form E nach ISO 1179-2

Profile sealing rings FKM

for male adaptor threads, sealing form E acc. ISO 1179-2

Juntas anulares con perfil FKM

para conexión de rosca, cierre forma E según ISO 1179-2

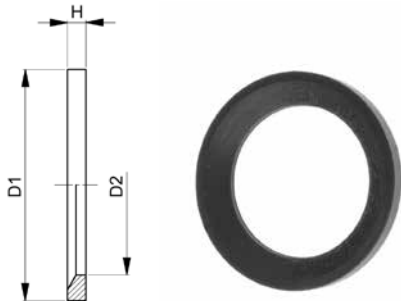

VDR-..M/R

Type-G / M	Mat.-Nr.	D1	D2	G	M	H	g/Stk
G=Rohrgewinde (zylindrisch)	G=BSP thread (parallel)				G=rosca de conexión (cilíndrica)		
VDR-R 3.8	XNN.62381.4715	19.0	14.5	3/8		1.5	1
VDR-R 1.2	XNN.62381.8515	24.0	18.5	1/2		1.5	1
VDR-M 12x1,5	XNN.62380.9815	14.5	10.0		12x1.5	1.5	1
VDR-M 16x1,5	XNN.62381.3815	19.0	14.0		16x1.5	1.5	1
VDR-M 18x1,5	XNN.62381.5715	21.0	15.5		18x1.5	1.5	1
VDR-M 20x1,5	XNN.62381.7815	23.0	18.0		20x1.5	1.5	1
VDR-M 22x1,5	XNN.62381.9615	24.5	19.5		22x1.5	1.5	1
VDR-R 1.8/M 10x1,0	XNN.62380.8410	12.0	8.5	1/8	10x1.0	1.0	1
VDR-R 1.4/M 14x1,5	XNN.62381.1615	16.5	11.5	1/4	14x1.5	1.5	1
VDR-R 3.4/M 26/27	XNN.62382.3915	29.0	24.0	3/4	27x2.0	1.5	1
VDR-R 1.1/M 33x2,0	XNN.62382.9720	35.5	29.5	1	33x2.0	2.0	1
VDR-R 5.4/M 42x2,0	XNN.62383.8820	46.0	39.0	1 1/4	42x2.0	2.0	1
VDR-R 3.2/M 48x2,0	XNN.62384.4720	50.5	44.5	1 1/2	48x2.0	2.0	1

M/G Außengewinde

M/G external threads

Rosca exterior M/G

**DIN 3869
ISO 1179**

O-Ringe FKM

für Dichtkegelanschluss

O-rings FKM

for taper connection

Juntas tóricas FKM

para conexión de junta cónica

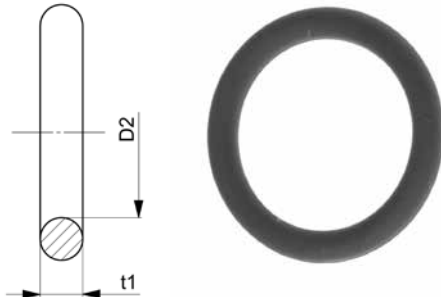

VOR

Type -D2 x t1	Mat.-Nr.	D1	g/Stk
O-RING FKM/80 4.00x1.50	XNN.61380.403	6.0	1
O-RING FKM/80 6.00x1.50	XNN.61380.603	8.0	1
O-RING FKM/80 7.50x1.50	XNN.61380.753	10.0	1
O-RING FKM/80 9.00x1.50	XNN.61380.903	12.0	1
O-RING FKM/80 12.00x2.00	XNN.61381.206	16.0	1
O-RING FKM/80 15.00x2.00	XNN.61381.506	18.0	1
O-RING FKM/80 16.30x2.40	XNN.61381.634	20.0	1
O-RING FKM/80 20.00x2.00	XNN.61382.004	22.0	1
O-RING FKM/80 20.36x2.40	XNN.61382.034	25.0	1
O-RING FKM/80 25.30x2.40	XNN.61382.534	30.0	1
O-RING FKM/80 26.00x2.00	XNN.61382.606	28.0	1
O-RING FKM/80 32.00x2.50	XNN.61383.205	35.0	1
O-RING FKM/80 33.30x2.40	XNN.61383.333	38.0	1
O-RING FKM/80 38.00x2.50	XNN.61383.803	42.0	1

O-RING FKM/80 12.00x2.00
(XNN.61381.206) passend für D1 = 14 mm,
15 mm und 16 mm

O-RING FKM/80 12.00x2.00
(XNN.61381.206) for D1 = 14 mm, 15 mm
and 16 mm

O-RING FKM/80 12.00x2.00
(XNN.61381.206) por D1 = 14 mm, 15 mm
y 16 mm

D1 = Größe des Dichtkegelanschlusses

D1 = dimension of the taper connection

D1 = medida de la conexión de junta cónica

NC-Klemmring-
verschraubungen

NC clamping ring
fittings

Racores de anillo
de apriete NC

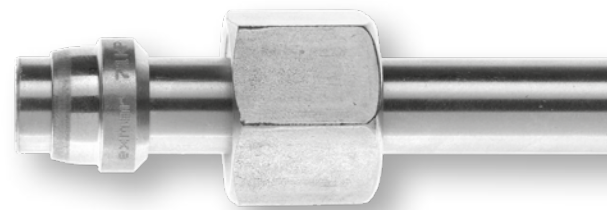
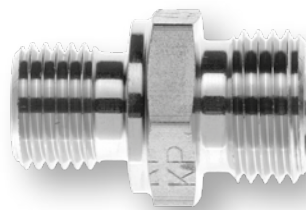

Seite/Page/Página	Seite/Page/Página	Seite/Page/Página
<p>NC-Rohrverschraubungen NC Tube fittings Racores de conexión NC</p>	<p>Winkel-Schottverschraubungen Bulkhead elbow fittings Racores pasatabiques a codo</p>	<p>Einstellbare Winkel-Einschraubversch. Adjustable male adaptor elbow fittings Racores para roscar en codo ajustables</p>
<p>Gerade Verschraubungen Straight fittings Racores rectos</p>	<p>NC-Einschraubverschraubungen NC Male adaptor fittings Racores para roscar NC</p>	<p>Einstellbare T-Versch. mit Dichtkegel Adjustable T fittings with taper Racores T ajustables c. junta cónica</p>
<p>Gerade Verschraubungen mit Dichtkegel Straight fittings with taper Racores rectos con junta cónica</p>	<p>Gerade Einschraubverschraubungen Straight male adaptor fittings Racores para roscar rectos</p>	<p>Einstellbare L-Versch. mit Dichtkegel Adjustable L fittings with taper Racores L ajustables con junta cónica</p>
<p>Winkelverschraubungen Elbow fittings Racores codo</p>	<p>Winkel-Einschraubverschraubungen Male adaptor elbow fittings Racores para roscar en codo</p>	<p>NC-Schwenkverschraubungen NC Banjo fittings Racores orientables NC</p>
<p>T-Verschraubungen T fittings Racores T</p>	<p>T-Einschraubverschraubungen Male adaptor T fittings Racores para roscar T</p>	<p>Winkel-Schwenkverschraubungen Banjo elbow fittings Racores orientables angulares</p>
<p>Kreuz-Verschraubungen Cross fittings Racores en cruz</p>	<p>L-Einschraubverschraubungen Male adaptor L fittings Racores para roscar L</p>	<p>NC-Aufschraub-/Manometerverschr. NC Female adaptor/Manometer fitt. Racores rectos/para manómetro NC</p>
<p>Verschlussverschraubungen Locking fittings Racores de cierre</p>	<p>NC-Einstellbare Verschraubungen NC Adjustable fittings Racores ajustables NC</p>	<p>Gerade Aufschraubverschraubungen Straight female adaptor fittings Racores atornillables rectos</p>
<p>Gerade Schottverschraubungen Bulkhead fittings Racores pasatabiques rectos</p>	<p>Einstellbare Winkelversch. mit Dichtkegel Adjustable elbow fittings with taper Racores ang. ajustables con junta cónica</p>	<p>Manometer-Anschlussverschraubungen Manometer fittings Racores para manómetro</p>

Seite/Page/Página

Seite/Page/Página

Gerade Messverschraubungen
Straight fittings with test gauge
Racores de medición rectos



NC-EMV-GV

Einschweiß-Schottverschraubungen
Weld-in bulkhead fittings
Racores de paso de mamparo para soldar



NC-ESV

NC-Reduzierschraubungen
NC Reducing fittings
Racores de reducción NC

NC-Einzelteile
NC Single parts
Componentes NC

Reduzierschr. mit Dichtkegel
Reducing fittings with taper
Racores de reducción c. junta cónica

20.58-20.61



NC-GRKO

NC-Überwurfmutter
NC nuts
Tuercas de unión

20.68



NC-UEM

Gerade Reduzierschraubungen
Straight reducing fittings
Racores de reducción rectos

20.62-20.63



NC-GR

NC-Klemmringe
NC clamping rings
Anillos de apriete NC

20.69



NC-R

T-Reduzierschraubungen
Reducing T fittings
Racores de reducción T

20.64



NC-TR

NC-Anschweißverschraubungen
NC Weldable fittings
Racores para soldar NC

Gerade Anschweißverschraubungen
Straight weld-on fittings
Racores para soldar rectos

20.65



NC-GAS

Winkelanschweißverschraubungen
Elbow weld-on fittings
Racores para soldar angulares

20.66



NC-WAS

Technische Information
NC-Klemmringverschraubungen

Technical information
NC Clamping ring fittings

Información técnica
Racores de anillo NC

Eigenschaften, Besonderheiten

- angelehnt an ISO 8434-1/DIN 2353
- Baureihen L und S
- korrosionsbeständig
- große Sortimentsvielfalt
- Überwurfmutter innen versilbert

Characteristics, specialities

- based on ISO 8434-1/DIN 2353
- series L and S
- corrosion resistant
- extensive product range
- nuts silver-plated inside

Características, particularidades

- similar a ISO 8434-1/DIN 2353
- series L y S
- resistencia a la corrosión
- amplio surtido
- tuercas de unión interior plateado

Funktionsprinzip

Die Abkürzung **NC** verweist auf die Eigenschaften der Verschraubung: **Non-Cutting**, **Non-Corrosive** = nicht schneidend, nicht rostend.

Operating principle

The abbreviation **NC** stands for the characteristics of the fittings: **Non-Cutting**, **Non-Corrosive**.

Principio de funcionamiento

La abreviatura **NC** se refiere a las características de la rosca: **Non-Cutting**, **Non-Corrosive** = no cortante, no oxidable.

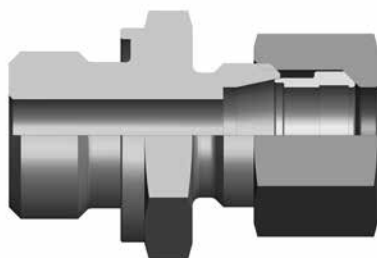

Vor der Montage
Before assembly
Antes del montaje

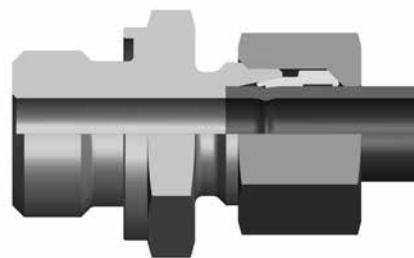

Nach der Montage
After assembly
Después del montaje

Werkstoff

Edelstahl 1.4571,
Legierung X 6 CrNiMoTi 17 12 2,
≈ AISI 316 Ti.
Andere hochwertige Werkstoffqualitäten
(Hastelloy®, Monel®, Titan, etc.) sind möglich.

Material

Stainless steel 1.4571,
alloy X 6 CrNiMoTi 17 12 2,
≈ AISI 316 Ti.
Other high quality materials (Hastelloy®,
Monel®, Titan, etc.) also available.

Materiales

Acero inoxidable 1.4571,
aleación X 6 CrNiMoTi 17 12 2,
≈ AISI 316 Ti.
Otras materiales de alta calidad (Hastelloy®,
Monel®, titanio, etc.) están disponibles.

Nenndruck PN

bis 500 bar

Pressure nominal PN

up to 500 bar

Presión nominal PN

hasta 500 bar

**Druckbereiche für
NC-Klemmringverschraubungen**

Baureihe	Rohr	Nenndruck
L: leicht	6 - 8 mm	PN 400 (bar)
	10 - 15 mm	PN 250 (bar)
	18 - 22 mm	PN 160 (bar)
S: schwer	6 - 8 mm	PN 500 (bar)
	10 - 12 mm	PN 400 (bar)
	14 mm	PN 300 (bar)
	16 - 20 mm	PN 200 (bar)
	25 mm	PN 100 (bar)

**Pressure range for
NC Clamping ring fittings**

Serie	Tube	Pressure nom.
L: light	6 - 8 mm	PN 400 (bar)
	10 - 15 mm	PN 250 (bar)
	18 - 22 mm	PN 160 (bar)
S: heavy	6 - 8 mm	PN 500 (bar)
	10 - 12 mm	PN 400 (bar)
	14 mm	PN 300 (bar)
	16 - 20 mm	PN 200 (bar)
	25 mm	PN 100 (bar)

**Rangos de presión para
Racores de anillo de apriete NC**

Serie	Tubo	Presión nom.
L: ligera	6 - 8 mm	PN 400 (bar)
	10 - 15 mm	PN 250 (bar)
	18 - 22 mm	PN 160 (bar)
S: pesada	6 - 8 mm	PN 500 (bar)
	10 - 12 mm	PN 400 (bar)
	14 mm	PN 300 (bar)
	16 - 20 mm	PN 200 (bar)
	25 mm	PN 100 (bar)

Technische Information

NC-Klemmringverschraubungen (Fort.)

Technical information

NC Clamping ring fittings (cont.)

Información técnica

Racores de anillo NC (cont.)

**Druckauswertungsgrad
in % des PN**

**Pressure coefficient
in % of PN**

**Grado de valoración de presión
en % de la PN**

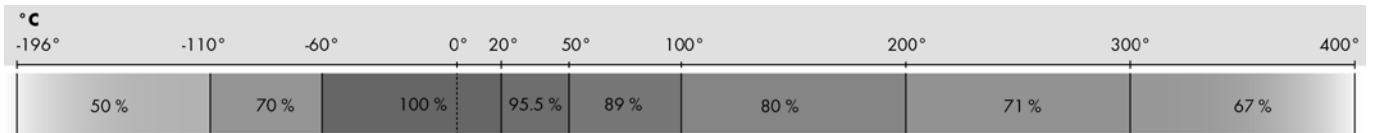

Temperaturbereich

-196°C bis +400°C

Achtung: Ausnahmen bilden weichgedichtete (Zusatz "WD") oder Dichtkegel-Verschraubungen (Zusatz "KO"), die nur in einem Bereich von -20°C bis +200°C eingesetzt werden können.

Temperature range

-196°C to +400°C

Attention: Excepted are FKM-sealed fittings (suppl. "WD") and fittings with taper (suppl. "KO"), which can be used from -20°C up to +200°C.

Rango de temperatura

-196°C hasta +400°C

Atención: La excepción son los racores con juntas blandas (código "WD") o de junta cónica (código "KO"), aptos solo para temperaturas de -20°C hasta +200°C.

Helium-Leckrate

mind. 10⁻⁸ mbar • l/s bei fachgerechter Montage; siehe Kapitel i für Montageanleitung.

Leak rate with helium

10⁻⁸ mbar • l/s min. when professionally assembled; see chapter i for installation instructions.

Tasa de fuga de helio

mín. 10⁻⁸ mbar • l/s con montaje correcto; para las instrucciones de montaje, consulte el capítulo i.

Vakuum

bis 10⁻⁴ mbar, höhere Werte möglich

Vacuum

up to 10⁻⁴ mbar, higher values are possible

Vacío

hasta 10⁻⁴ mbar; posibilidad de valores superiores

Anzuschließende Rohre

Nahtlose, gezogene Präzisionsrohre aus Edelstahl (DIN EN 10216-5/EN ISO 1127, Toleranzkl. D4/T3) mit sauberer, glatter Oberfläche oder Kunststoffrohre. Außendurchmesser innerhalb ± 0,1 mm; Ausnahme: Kunststoffrohre. Siehe auch Kapitel Rohre und Schläuche. Weitere Materialien auf Anfrage.

Tubes to use

Seamless, cold-drawn, high precision stainless steel tubes (according to DIN EN 10216-5/EN ISO 1127 tolerance class D4/T3) with clean, smooth surface or plastic tubes. Outer diameter within ± 0,1 mm; exception: plastic tubes. See also chapter tubes and hoses. Other materials on request.

Tubos para conectar

Tubos de precisión estirados sin costuras, de acero inoxidable (DIN EN 10216-5/EN ISO 1127, clase de tolerancia D4/T3) con superficie lisa limpia o tubos de plástico. Diámetro exterior con tolerancia de ± 0,1 mm; excepción: tubos de plástico. Véase también el capítulo Tubos y mangueras. Otros materiales bajo demanda.

Werkzeugnis

Werden Bescheinigungen über Materialprüfungen nach DIN EN 10 204 gewünscht, so ist dies bei Bestellung anzugeben (Abnahmeprüfzeugnis 3.1 gegen Berechnung).

Material certificates

Any request for documents on material tests according to DIN EN 10 204 should be made when placing the order (charges apply to inspection certificates 3.1).

Certificado de material

Si se necesitan certificados de ensayos de material según DIN EN 10 204, deberá especificarse al realizar el pedido (se facturará a partir del certificado de recepción 3.1).

Gerade Verschraubungen
Straight fittings
Racores rectos

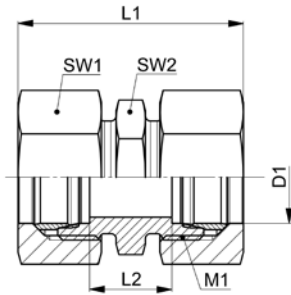

NC-GV-..L/S

Type -D1	Mat.-Nr.	PN	M1	L1	L2	SW1	SW2	g/Stk
NC-GV-06L	718.1020.060.20	400	12x1.5	42.0	10.0	14	12	35
NC-GV-08L	718.1020.080.20	400	14x1.5	43.0	11.0	17	14	50
NC-GV-10L	718.1020.100.20	250	16x1.5	48.0	13.0	19	17	65
NC-GV-12L	718.1020.120.20	250	18x1.5	48.0	14.0	22	19	85
NC-GV-15L	718.1020.150.20	250	22x1.5	52.0	16.0	27	24	140
NC-GV-18L	718.1020.180.20	160	26x1.5	51.0	16.0	32	27	201
NC-GV-22L	718.1020.220.20	160	30x2.0	60.0	20.0	36	32	274
NC-GV-06S	718.1020.060.30	500	14x1.5	48.0	16.0	17	14	65
NC-GV-08S	718.1020.080.30	500	16x1.5	50.0	18.0	19	17	83
NC-GV-10S	718.1020.100.30	400	18x1.5	55.0	17.0	22	19	110
NC-GV-12S	718.1020.120.30	400	20x1.5	58.0	19.0	24	22	135
NC-GV-14S	718.1020.140.30	300	22x1.5	64.0	22.0	27	24	187
NC-GV-16S	718.1020.160.30	200	24x1.5	66.0	21.0	30	27	229
NC-GV-20S	718.1020.200.30	200	30x2.0	76.0	23.0	36	32	350
NC-GV-25S	718.1020.250.30	100	36x2.0	83.0	26.0	46	41	672

Baumaße sind Ungefährmaße bei angezogener Überwurfmutter.

Sizes are approximate dimensions at tightened nut.

Las medidas son aproximadas con la tuerca de unión apretada.

Gerade Verschraubungen mit Dichtkegel und O-Ring
Straight fittings with taper and O-ring
Racores rectos con junta cónica y junta tórica

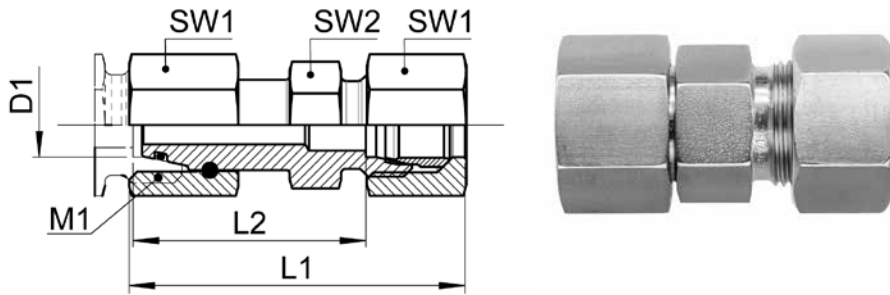

20

NC-GKO-..L

Type -D1	Mat.-Nr.	PN	M1	L1	L2	SW1	SW2	g/Stk
NC-GKO-06L	718.1050.060.20	315	12x1.5	52.5	36.0	14	12	44
NC-GKO-08L	718.1050.080.20	315	14x1.5	52.5	36.0	17	14	62
NC-GKO-10L	718.1050.100.20	250	16x1.5	53.0	36.0	19	17	79
NC-GKO-12L	718.1050.120.20	250	18x1.5	53.0	36.0	22	19	98
NC-GKO-15L	718.1050.150.20	250	22x1.5	53.0	36.0	27	24	170
NC-GKO-18L	718.1050.180.20	160	26x1.5	53.5	36.0	32	27	224
NC-GKO-22L	718.1050.220.20	160	30x2.0	59.5	40.0	36	32	317

Baumaße sind Ungefährmaße bei angezogener Überwurfmutter.

Sizes are approximate dimensions at tightened nut.

Las medidas son aproximadas con la tuerca de unión apretada.

Dichtungsmaterial: FKM (andere Werkstoffe auf Anfrage)

Sealing material: FKM (other materials on request)

Material de junta tórica: FKM (otros materiales bajo demanda)

D1=Rohr außen-Ø
 M1=metrisches Anschlußgewinde

D1=tube outside diameter
 M1=metric connecting thread

D1=Ø exterior del tubo
 M1=rosca métrica conexión

Winkelverschraubungen
Elbow fittings
Racores codo

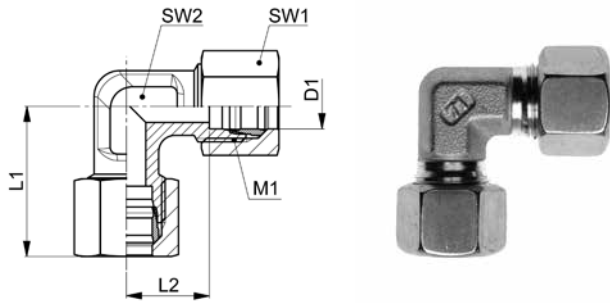

NC-WV-..L/S

Type -D1	Mat.-Nr.	PN	M1	L1	L2	SW1	SW2	g/Stk
NC-WV-06L	718.2000.060.20	400	12x1.5	28.0	12.0	14	12	42
NC-WV-08L	718.2000.080.20	400	14x1.5	30.0	14.0	17	12	59
NC-WV-10L	718.2000.100.20	250	16x1.5	32.5	15.0	19	14	74
NC-WV-12L	718.2000.120.20	250	18x1.5	34.0	17.0	22	17	103
NC-WV-15L	718.2000.150.20	250	22x1.5	39.0	21.0	27	19	169
NC-WV-18L	718.2000.180.20	160	26x1.5	41.0	23.5	32	24	248
NC-WV-22L	718.2000.220.20	160	30x2.0	47.5	27.5	36	27	320
NC-WV-06S	718.2000.060.30	500	14x1.5	32.0	16.0	17	12	74
NC-WV-08S	718.2000.080.30	500	16x1.5	33.0	17.0	19	14	95
NC-WV-10S	718.2000.100.30	400	18x1.5	36.5	17.5	22	17	128
NC-WV-12S	718.2000.120.30	400	20x1.5	41.0	21.5	24	17	159
NC-WV-14S	718.2000.140.30	300	22x1.5	43.0	22.0	27	19	210
NC-WV-16S	718.2000.160.30	200	24x1.5	47.0	24.5	30	24	260
NC-WV-20S	718.2000.200.30	200	30x2.0	53.0	26.5	36	27	410
NC-WV-25S	718.2000.250.30	100	36x2.0	58.5	30.0	46	36	776

Baumaße sind Ungefährmaße bei angezogener Überwurfmutter.

Sizes are approximate dimensions at tightened nut.

Las medidas son aproximadas con la tuerca de unión apretada.

T-Verschraubungen

T fittings

Racores T

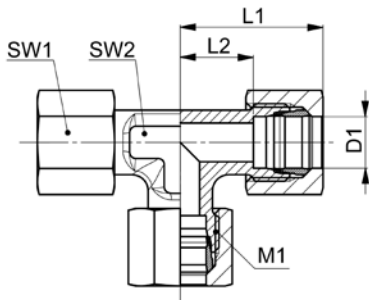

NC-TV-..L/S

Type -D1	Mat.-Nr.	PN	M1	L1	L2	SW1	SW2	g/Stk
NC-TV-06L	718.3000.060.20	400	12x1.5	28.0	12.0	14	12	51
NC-TV-08L	718.3000.080.20	400	14x1.5	30.0	14.0	17	12	85
NC-TV-10L	718.3000.100.20	250	16x1.5	32.5	15.0	19	14	106
NC-TV-12L	718.3000.120.20	250	18x1.5	34.0	17.0	22	17	140
NC-TV-15L	718.3000.150.20	250	22x1.5	39.0	21.0	27	19	240
NC-TV-18L	718.3000.180.20	160	26x1.5	41.0	23.5	32	24	348
NC-TV-22L	718.3000.220.20	160	30x2.0	47.5	27.5	36	27	468
NC-TV-06S	718.3000.060.30	500	14x1.5	32.0	16.0	17	12	110
NC-TV-08S	718.3000.080.30	500	16x1.5	33.0	17.0	19	14	134
NC-TV-10S	718.3000.100.30	400	18x1.5	36.5	17.5	22	17	190
NC-TV-12S	718.3000.120.30	400	20x1.5	41.0	21.5	24	17	227
NC-TV-14S	718.3000.140.30	300	22x1.5	43.0	22.0	27	19	300
NC-TV-16S	718.3000.160.30	200	24x1.5	47.0	24.5	30	24	390
NC-TV-20S	718.3000.200.30	200	30x2.0	53.0	26.5	36	27	590
NC-TV-25S	718.3000.250.30	100	36x2.0	58.5	30.0	46	36	1180

Baumaße sind Ungefährmaße bei angezogener Überwurfmutter.

Sizes are approximate dimensions at tightened nut.

Las medidas son aproximadas con la tuerca de unión apretada.

D1=Rohr außen-Ø
M1=metrisches Anschlußgewinde

D1=tube outside diameter
M1=metric connecting thread

D1=Ø exterior del tubo
M1=rosca métrica conexión

Kreuz-Verschraubungen

Cross fittings

Racores en cruz

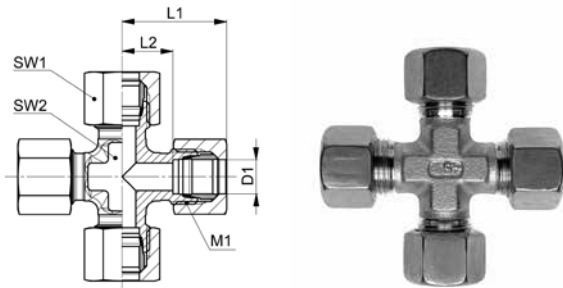

NC-KV-..L/S

Type -D1	Mat.-Nr.	PN	M1	L1	L2	SW1	SW2	g/Stk
NC-KV-06L	718.4000.060.20	400	12x1.5	28.0	12.0	14	12	80
NC-KV-08L	718.4000.080.20	400	14x1.5	30.0	14.0	17	12	109
NC-KV-10L	718.4000.100.20	250	16x1.5	32.0	15.0	19	14	158
NC-KV-12L	718.4000.120.20	250	18x1.5	33.5	17.0	22	17	185
NC-KV-15L	718.4000.150.20	250	22x1.5	38.0	21.0	27	19	338
NC-KV-18L	718.4000.180.20	160	26x1.5	40.5	23.5	32	24	445
NC-KV-22L	718.4000.220.20	160	30x2.0	47.0	27.5	36	27	600
NC-KV-06S	718.4000.060.30	500	14x1.5	32.0	16.0	17	12	140
NC-KV-08S	718.4000.080.30	500	16x1.5	33.0	17.0	19	14	175
NC-KV-10S	718.4000.100.30	400	18x1.5	36.0	17.5	22	17	235
NC-KV-12S	718.4000.120.30	400	20x1.5	40.5	21.5	24	17	315
NC-KV-14S	718.4000.140.30	300	22x1.5	42.5	22.0	27	19	385
NC-KV-16S	718.4000.160.30	200	24x1.5	46.0	24.5	30	24	500
NC-KV-20S	718.4000.200.30	200	30x2.0	51.5	26.5	36	27	857
NC-KV-25S	718.4000.250.30	100	36x2.0	57.0	30.0	46	36	1250

Baumaße sind Ungefährmaße bei angezogener Überwurfmutter.

Sizes are approximate dimensions at tightened nut.

Las medidas son aproximadas con la tuerca de unión apretada.

Verschlussverschraubungen
Locking fittings
Racores de cierre

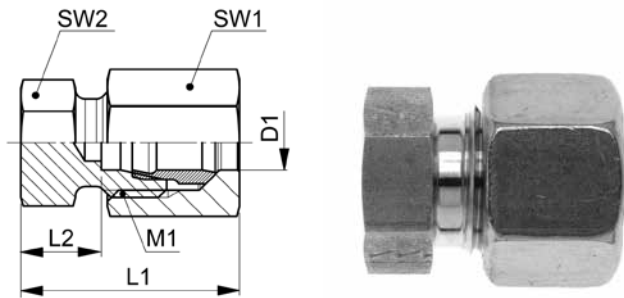

20

NC-VSA-..L/S

Type -D1	Mat.-Nr.	PN	M1	L1	L2	L3	SW1	SW2	g/Stk
NC-VSA-06L	718.1205.060.20	400	12x1.5	25.0	16.0	16.0	14	12	22
NC-VSA-08L	718.1205.080.20	400	14x1.5	27.0	16.0	16.0	17	14	30
NC-VSA-10L	718.1205.100.20	250	16x1.5	29.5	17.5	19.0	19	17	38
NC-VSA-12L	718.1205.120.20	250	18x1.5	29.0	17.0	19.0	22	19	50
NC-VSA-15L	718.1205.150.20	250	22x1.5	33.0	18.0	22.0	27	24	84
NC-VSA-18L	718.1205.180.20	160	26x1.5	32.0	17.5	22.0	32	27	124
NC-VSA-22L	718.1205.220.20	160	30x2.0	38.5	20.0	26.0	36	32	166
NC-VSA-06S	718.1205.060.30	500	14x1.5	27.0	16.0	18.0	17	14	36
NC-VSA-08S	718.1205.080.30	500	16x1.5	29.0	16.0	20.0	19	17	42
NC-VSA-10S	718.1205.100.30	400	18x1.5	31.5	19.0	20.0	22	19	64
NC-VSA-12S	718.1205.120.30	400	20x1.5	32.0	19.5	20.0	24	22	78
NC-VSA-14S	718.1205.140.30	300	22x1.5	37.0	21.0	24.0	27	24	118
NC-VSA-16S	718.1205.160.30	200	24x1.5	38.0	22.5	24.0	30	27	142
NC-VSA-20S	718.1205.200.30	200	30x2.0	44.0	26.5	28.0	36	32	236
NC-VSA-25S	718.1205.250.30	100	36x2.0	46.5	28.5	30.0	46	41	448

Baumaße sind Ungefährmaße bei angezogener Überwurfmutter.

Sizes are approximate dimensions at tightened nut.

Las medidas son aproximadas con la tuerca de unión apretada.

D1=Rohr außen-Ø
M1=metrisches Anschlußgewinde

D1=tube outside diameter
M1=metric connecting thread

D1=Ø exterior del tubo
M1=rosca métrica conexión

Gerade Schottverschraubungen
Bulkhead fittings
Racores pasatabiques rectos

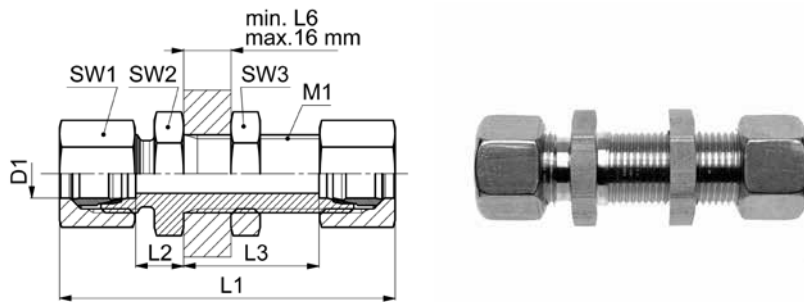

NC-GSV-..L/S

Type -D1	Mat.-Nr.	PN	M1	L1	L2	L3	SW1	SW2	SW3	g/Stk
NC-GSV-06L	718.1500.060.20	400	12x1.5	66.0	7.0	27.0	14	17	17	72
NC-GSV-08L	718.1500.080.20	400	14x1.5	67.0	8.0	27.0	17	19	19	83
NC-GSV-10L	718.1500.100.20	250	16x1.5	72.0	10.0	28.0	19	22	22	125
NC-GSV-12L	718.1500.120.20	250	18x1.5	72.0	10.0	29.0	22	24	24	135
NC-GSV-15L	718.1500.150.20	250	22x1.5	77.0	12.0	31.0	27	27	30	230
NC-GSV-18L	718.1500.180.20	160	26x1.5	80.0	13.5	32.5	32	32	36	345
NC-GSV-22L	718.1500.220.20	160	30x2.0	90.0	16.5	34.5	36	36	41	435
NC-GSV-06S	718.1500.060.30	500	14x1.5	73.0	12.0	29.0	17	19	19	112
NC-GSV-08S	718.1500.080.30	500	16x1.5	74.0	13.0	29.0	19	22	22	132
NC-GSV-10S	718.1500.100.30	400	18x1.5	81.0	14.5	29.5	22	24	24	170
NC-GSV-12S	718.1500.120.30	400	20x1.5	83.0	14.5	30.5	24	27	27	215
NC-GSV-14S	718.1500.140.30	300	22x1.5	90.0	17.0	32.0	27	30	30	322
NC-GSV-16S	718.1500.160.30	200	24x1.5	91.0	16.5	31.5	30	32	32	345
NC-GSV-20S	718.1500.200.30	200	30x2.0	104.0	17.5	33.5	36	41	41	575
NC-GSV-25S	718.1500.250.30	100	36x2.0	112.0	20.0	35.0	46	46	46	949

Baumaße sind Ungefährmaße bei angezogener Überwurfmutter.

Sizes are approximate dimensions at tightened nut.

Las medidas son aproximadas con la tuerca de unión apretada.

für D1 ≤ 18 mm L6 = 3 mm
 für D1 > 18 mm L6 = 4 mm

for D1 ≤ 18 mm L6 = 3 mm
 for D1 > 18 mm L6 = 4 mm

para D1 ≤ 18 mm L6 = 3 mm
 para D1 > 18 mm L6 = 4 mm

Winkel-Schottverschraubungen

Bulkhead elbow fittings

Racores pasatabiques a codo

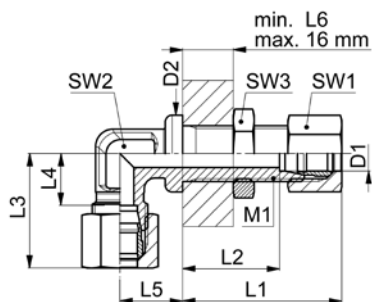

20

NC-WSV-..L/S

Type -D1	Mat.-Nr.	PN	D2	M1	L1	L2	L3	L4	L5	SW1	SW2	SW3	g/Stk
NC-WSV-06L	718.2700.060.20	400	17.0	12x1.5	43.0	28.0	27.0	12.0	14.0	14	12	17	73
NC-WSV-08L	718.2700.080.20	400	19.0	14x1.5	43.0	30.0	29.0	14.0	17.0	17	12	19	92
NC-WSV-10L	718.2700.100.20	250	22.0	16x1.5	45.5	32.5	30.5	15.0	18.0	19	14	22	172
NC-WSV-12L	718.2700.120.20	250	24.0	18x1.5	46.0	34.0	32.0	17.0	20.0	22	17	24	215
NC-WSV-15L	718.2700.150.20	250	27.0	22x1.5	49.0	39.0	36.5	21.0	23.0	27	19	30	262
NC-WSV-18L	718.2700.180.20	160	32.0	26x1.5	50.0	41.0	40.0	23.5	24.0	32	24	36	380
NC-WSV-22L	718.2700.220.20	160	36.0	30x2.0	54.5	47.5	44.0	27.5	30.0	36	27	41	490
NC-WSV-06S	718.2700.060.30	500	19.0	14x1.5	45.0	32.0	31.0	29.0	17.0	17	12	19	117
NC-WSV-08S	718.2700.080.30	500	22.0	16x1.5	45.0	33.5	32.5	29.0	18.0	19	14	22	185
NC-WSV-10S	718.2700.100.30	400	24.0	18x1.5	48.5	36.5	35.0	29.5	20.0	22	17	24	195
NC-WSV-12S	718.2700.120.30	400	27.0	20x1.5	50.0	41.0	38.0	30.5	21.0	24	17	27	245
NC-WSV-14S	718.2700.140.30	300	27.0	22x1.5	53.0	43.0	38.0	32.0	23.0	27	19	30	375
NC-WSV-16S	718.2700.160.30	200	30.0	24x1.5	54.0	47.0	43.0	31.5	24.0	30	24	32	395
NC-WSV-20S	718.2700.200.30	200	36.0	30x2.0	60.0	53.0	50.0	33.5	30.0	36	27	41	606
NC-WSV-25S	718.2700.250.30	100	42.0	36x2.0	63.5	58.5	56.0	35.0	34.0	46	36	46	1050

Baumaße sind Ungefährmaße bei angezogener Überwurfmutter.

Sizes are approximate dimensions at tightened nut.

Las medidas son aproximadas con la tuerca de unión apretada.

für D1 ≤ 18 mm L6 = 3 mm
für D1 > 18 mm L6 = 4 mm

for D1 ≤ 18 mm L6 = 3 mm
for D1 > 18 mm L6 = 4 mm

para D1 ≤ 18 mm L6 = 3 mm
para D1 > 18 mm L6 = 4 mm

D1=Rohr außen-Ø
M1=metrisches Anschlußgewinde

D1=tube outside diameter
M1=metric connecting thread

D1=Ø exterior del tubo
M1=rosca métrica conexión

Gerade Einschraubverschraubungen

Abdichtung durch Dichtkante Form B nach DIN 3852-2

Straight male adaptor fittings

sealing edge form B acc. DIN 3852-2

Racores para roscar rectos

cierre hermético mediante borde de obturación forma B según DIN 3852-2

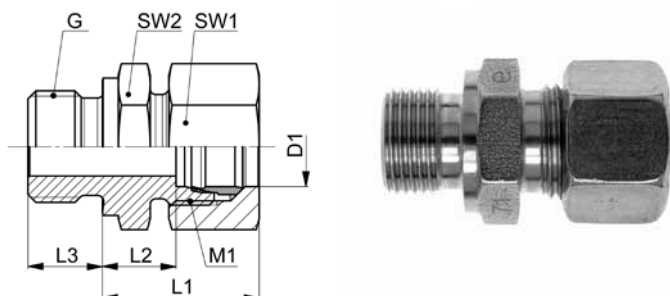

NC-GEV-..LR

Type-D1 G	Mat.-Nr.	PN	G	M1	L1	L2	L3	SW1	SW2	g/Stk
G=Rohrgewinde (zylindrisch)		G=BSP thread (parallel)				G=rosca de conexión (cilíndrica)				
NC-GEV-06LR 1.8	718.1141.100.20	400	1/8	12x1.5	24.5	8.5	8.0	14	14	25
NC-GEV-06LR 1.4	718.1141.110.20	400	1/4	12x1.5	26.0	10.0	12.0	14	19	40
NC-GEV-06LR 3.8	718.1141.120.20	400	3/8	12x1.5	27.5	11.5	12.0	14	22	58
NC-GEV-06LR 1.2	718.1141.125.20	400	1/2	12x1.5	29.0	13.0	14.0	14	27	100
NC-GEV-08LR 1.8	718.1141.160.20	400	1/8	14x1.5	24.5	8.5	8.0	17	14	32
NC-GEV-08LR 1.4	718.1141.170.20	400	1/4	14x1.5	26.0	10.0	12.0	17	19	43
NC-GEV-08LR 3.8	718.1141.180.20	400	3/8	14x1.5	28.5	12.5	12.0	17	19	59
NC-GEV-08LR 1.2	718.1141.185.20	400	1/2	14x1.5	29.0	13.0	14.0	17	27	99
NC-GEV-10LR 1.8	718.1141.265.20	250	1/8	16x1.5	27.5	10.5	8.0	19	17	43
NC-GEV-10LR 1.4	718.1141.270.20	250	1/4	16x1.5	28.0	11.0	12.0	19	19	50
NC-GEV-10LR 3.8	718.1141.280.20	250	3/8	16x1.5	29.5	12.5	12.0	19	22	64
NC-GEV-10LR 1.2	718.1141.285.20	250	1/2	16x1.5	31.0	14.0	14.0	19	27	102
NC-GEV-10LR 3.4	718.1141.290.20	250	3/4	16x1.5	31.0	14.0	16.0	19	32	124
NC-GEV-10LR 1.1	718.1141.295.20	250	1	16x1.5	34.0	17.0	18.0	19	41	194
NC-GEV-12LR 1.8	718.1141.375.20	250	1/8	18x1.5	28.0	11.5	8.0	22	19	58
NC-GEV-12LR 1.4	718.1141.380.20	250	1/4	18x1.5	28.5	12.0	12.0	22	19	62
NC-GEV-12LR 3.8	718.1141.390.20	250	3/8	18x1.5	29.0	12.5	12.0	22	22	70
NC-GEV-12LR 1.2	718.1141.400.20	250	1/2	18x1.5	29.5	13.0	14.0	22	27	101
NC-GEV-12LR 3.4	718.1141.405.20	250	3/4	18x1.5	30.5	14.0	16.0	22	32	153
NC-GEV-12LR 1.1	718.1141.408.20	250	1	18x1.5	33.5	17.0	18.0	22	41	208
NC-GEV-15LR 1.4	718.1141.528.20	250	1/4	22x1.5	30.0	13.0	12.0	27	24	98
NC-GEV-15LR 3.8	718.1141.532.20	250	3/8	22x1.5	30.5	13.5	12.0	27	24	102
NC-GEV-15LR 1.2	718.1141.534.20	250	1/2	22x1.5	31.0	14.0	14.0	27	27	114
NC-GEV-15LR 3.4	718.1141.536.20	250	3/4	22x1.5	32.0	15.0	16.0	27	32	172
NC-GEV-15LR 1.1	718.1141.541.20	250	1	22x1.5	35.0	18.0	18.0	27	41	228
NC-GEV-18LR 1.2	718.1141.646.20	160	1/2	26x1.5	31.5	14.5	14.0	32	27	142
NC-GEV-18LR 3.8	718.1141.644.20	160	3/8	26x1.5	31.5	14.5	12.0	32	27	136
NC-GEV-18LR 3.4	718.1141.648.20	160	3/4	26x1.5	31.5	14.5	16.0	32	32	185
NC-GEV-18LR 1.1	718.1141.652.20	160	1	26x1.5	35.0	17.5	18.0	32	41	254
NC-GEV-22LR 3.8	718.1141.763.20	160	3/8	30x2.0	35.5	16.0	12.0	36	32	180
NC-GEV-22LR 1.2	718.1141.764.20	160	1/2	30x2.0	36.0	16.5	14.0	36	32	200
NC-GEV-22LR 3.4	718.1141.768.20	160	3/4	30x2.0	36.0	16.5	16.0	36	32	196
NC-GEV-22LR 1.1	718.1141.770.20	160	1	30x2.0	37.0	17.5	18.0	36	41	289
NC-GEV-22LR 5.4	718.1141.771.20	160	1 1/4	30x2.0	38.0	18.5	20.0	36	50	368

Baumäße sind Ungefährmaße bei angezogener Überwurfmutter.

Sizes are approximate dimensions at tightened nut.

Las medidas son aproximadas con la tuerca de unión apretada.

D1=Rohr außen-Ø
M1=metrisches Anschlußgewinde

D1=tube outside diameter
M1=metric connecting thread

D1=Ø exterior del tubo
M1=rosca métrica conexión

Gerade Einschraubverschraubungen

Abdichtung durch Profildichtring Form E nach ISO 1179-2

Straight male adaptor fittings

profile sealing ring form E acc. ISO 1179-2

Racores para roscar rectos

cierre hermético mediante junta con perfil forma E según ISO 1179-2

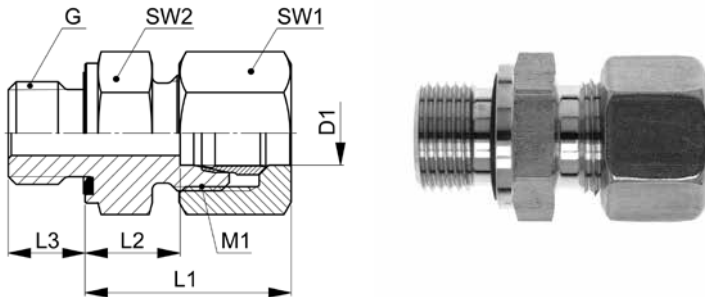

20

NC-GEV-..LR WD

Type-D1 G	Mat.-Nr.	PN	G	M1	L1	L2	L3	SW1	SW2	g/Stk
G=Rohrgewinde (zylindrisch)		G=BSP thread (parallel)				G=rosca de conexión (cilíndrica)				
NC-GEV-06LR 1.8 WD	718.1171.100.20	400	1/8	12x1.5	24.5	8.5	8.0	14	14	25
NC-GEV-06LR 1.4 WD	718.1171.110.20	400	1/4	12x1.5	26.0	10.0	12.0	14	19	40
NC-GEV-06LR 3.8 WD	718.1171.120.20	400	3/8	12x1.5	27.5	11.5	12.0	14	22	58
NC-GEV-06LR 1.2 WD	718.1171.125.20	400	1/2	12x1.5	29.0	13.0	14.0	14	27	100
NC-GEV-08LR 1.8 WD	718.1171.160.20	400	1/8	14x1.5	25.5	8.5	8.0	17	14	37
NC-GEV-08LR 1.4 WD	718.1171.170.20	400	1/4	14x1.5	26.0	10.0	12.0	17	19	63
NC-GEV-08LR 3.8 WD	718.1171.180.20	400	3/8	14x1.5	27.5	12.5	12.0	17	22	59
NC-GEV-08LR 1.2 WD	718.1171.185.20	400	1/2	14x1.5	29.0	13.0	14.0	17	27	99
NC-GEV-10LR 1.8 WD	718.1171.265.20	250	1/8	16x1.5	27.5	10.5	8.0	19	17	43
NC-GEV-10LR 1.4 WD	718.1171.270.20	250	1/4	16x1.5	28.0	11.0	12.0	19	19	50
NC-GEV-10LR 3.8 WD	718.1171.280.20	250	3/8	16x1.5	29.5	12.5	12.0	19	22	64
NC-GEV-10LR 1.2 WD	718.1171.285.20	250	1/2	16x1.5	31.0	14.0	14.0	19	27	102
NC-GEV-12LR 1.8 WD	718.1171.375.20	250	1/8	18x1.5	26.0	11.5	8.0	22	19	54
NC-GEV-12LR 1.4 WD	718.1171.380.20	250	1/4	18x1.5	28.5	12.0	12.0	22	19	62
NC-GEV-12LR 3.8 WD	718.1171.390.20	250	3/8	18x1.5	29.0	12.5	12.0	22	22	70
NC-GEV-12LR 1.2 WD	718.1171.400.20	250	1/2	18x1.5	29.5	13.0	14.0	22	27	101
NC-GEV-12LR 3.4 WD	718.1171.405.20	250	3/4	18x1.5	30.5	14.0	16.0	22	32	102
NC-GEV-15LR 1.4 WD	718.1171.528.20	250	1/4	22x1.5	30.0	13.0	12.0	27	24	98
NC-GEV-15LR 3.8 WD	718.1171.532.20	250	3/8	22x1.5	30.5	13.5	12.0	27	24	102
NC-GEV-15LR 1.2 WD	718.1171.534.20	250	1/2	22x1.5	31.0	14.0	14.0	27	27	114
NC-GEV-15LR 3.4 WD	718.1171.536.20	250	3/4	22x1.5	32.0	15.0	16.0	27	32	172
NC-GEV-18LR 3.8 WD	718.1171.644.20	160	3/8	26x1.5	31.5	14.5	12.0	32	27	136
NC-GEV-18LR 1.2 WD	718.1171.646.20	160	1/2	26x1.5	31.5	14.5	14.0	32	27	142
NC-GEV-18LR 3.4 WD	718.1171.648.20	160	3/4	26x1.5	31.5	14.5	16.0	32	32	185
NC-GEV-22LR 1.2 WD	718.1171.764.20	160	1/2	30x2.0	35.5	16.5	14.0	36	32	200
NC-GEV-22LR 3.4 WD	718.1171.768.20	160	3/4	30x2.0	36.0	16.5	16.0	36	32	196
NC-GEV-22LR 1.1 WD	718.1171.770.20	160	1	30x2.0	37.0	17.5	18.0	36	41	289
NC-GEV-22LR 5.4 WD	718.1171.771.20	160	1 1/4	30x2.0	38.0	18.5	20.0	36	50	382

Baumaße sind Ungefährmaße bei angezogener Überwurfmutter.

Sizes are approximate dimensions at tightened nut.

Las medidas son aproximadas con la tuerca de unión apretada.

Dichtungsmaterial: FKM (andere Werkstoffe auf Anfrage)

Sealing material: FKM (other materials on request)

Material de junta tórica: FKM (otros materiales bajo demanda)

D1=Rohr außen-Ø
M1=metrisches Anschlußgewinde

D1=tube outside diameter
M1=metric connecting thread

D1=Ø exterior del tubo
M1=rosca métrica conexión

Gerade Einschraubverschraubungen

Abdichtung durch Dichtkante Form B nach DIN 3852-2

Straight male adaptor fittings

sealing edge form B acc. DIN 3852-2

Racores para roscar rectos

cierre hermético mediante borde de obturación forma B según DIN 3852-2

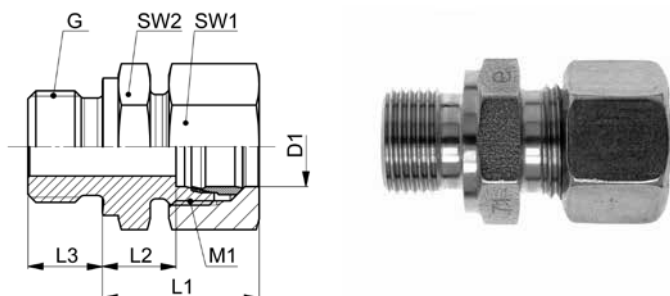

NC-GEV-..SR

Type-D1 G	Mat.-Nr.	PN	G	M1	L1	L2	L3	SW1	SW2	g/Stk
G=Rohrgewinde (zylindrisch)		G=BSP thread (parallel)				G=rosca de conexión (cilíndrica)				
NC-GEV-06SR 1.8	718.1141.100.30	500	1/8	14x1.5	28.5	12.5	8.0	17	14	40
NC-GEV-06SR 1.4	718.1141.110.30	500	1/4	14x1.5	29.0	13.0	12.0	17	19	54
NC-GEV-06SR 3.8	718.1141.120.30	500	3/8	14x1.5	31.5	15.5	12.0	17	22	63
NC-GEV-06SR 1.2	718.1141.125.30	500	1/2	14x1.5	34.0	18.0	12.0	17	27	107
NC-GEV-06SR 3.4	718.1141.126.30	500	3/4	14x1.5	36.0	20.0	12.0	17	32	152
NC-GEV-08SR 1.8	718.1141.160.30	500	1/8	16x1.5	30.5	14.5	12.0	19	17	58
NC-GEV-08SR 1.4	718.1141.170.30	500	1/4	16x1.5	31.0	15.0	12.0	19	19	63
NC-GEV-08SR 3.8	718.1141.180.30	500	3/8	16x1.5	31.5	15.5	12.0	19	22	82
NC-GEV-08SR 1.2	718.1141.185.30	500	1/2	16x1.5	34.0	18.0	14.0	19	27	108
NC-GEV-10SR 1.8	718.1141.265.30	400	1/8	18x1.5	32.5	14.0	8.0	22	19	77
NC-GEV-10SR 1.4	718.1141.270.30	400	1/4	18x1.5	33.0	14.5	12.0	22	19	73
NC-GEV-10SR 3.8	718.1141.280.30	400	3/8	18x1.5	33.5	15.0	12.0	22	22	89
NC-GEV-10SR 1.2	718.1141.285.30	400	1/2	18x1.5	36.0	17.5	14.0	22	27	125
NC-GEV-10SR 3.4	718.1141.290.30	400	3/4	18x1.5	38.0	19.5	16.0	22	32	208
NC-GEV-12SR 1.4	718.1141.380.30	400	1/4	20x1.5	35.5	16.5	12.0	24	22	91
NC-GEV-12SR 3.8	718.1141.390.30	400	3/8	20x1.5	36.0	17.0	12.0	24	22	100
NC-GEV-12SR 1.2	718.1141.400.30	400	1/2	20x1.5	36.5	17.5	14.0	24	27	135
NC-GEV-12SR 3.4	718.1141.405.30	400	3/4	20x1.5	36.5	17.5	16.0	24	32	192
NC-GEV-14SR 1.4	718.1141.500.30	300	1/4	22x1.5	36.5	16.0	12.0	27	24	118
NC-GEV-14SR 3.8	718.1141.502.30	300	3/8	22x1.5	39.0	18.5	12.0	27	24	130
NC-GEV-14SR 1.2	718.1141.504.30	300	1/2	22x1.5	39.5	19.0	14.0	27	27	154
NC-GEV-14SR 3.4	718.1141.506.30	300	3/4	22x1.5	41.5	21.0	16.0	27	32	195
NC-GEV-14SR 1.1	718.1141.510.30	300	1	22x1.5	43.5	23.0	18.0	27	41	350
NC-GEV-16SR 3.8	718.1141.564.30	200	3/8	24x1.5	39.5	18.0	12.0	30	27	156
NC-GEV-16SR 1.2	718.1141.566.30	200	1/2	24x1.5	40.0	18.5	14.0	30	27	161
NC-GEV-16SR 3.4	718.1141.568.30	200	3/4	24x1.5	42.0	20.5	16.0	30	32	240
NC-GEV-16SR 1.1	718.1141.570.30	200	1	24x1.5	44.0	22.5	18.0	30	41	359
NC-GEV-20SR 1.2	718.1141.706.30	200	1/2	30x2.0	45.5	20.5	14.0	36	32	245
NC-GEV-20SR 3.4	718.1141.708.30	200	3/4	30x2.0	45.5	20.5	16.0	36	32	277
NC-GEV-20SR 1.1	718.1141.712.30	200	1	30x2.0	47.5	22.5	18.0	36	41	387
NC-GEV-20SR 5.4	718.1141.715.30	200	1 1/4	30x2.0	47.5	22.5	20.0	36	50	574
NC-GEV-20SR 3.2	718.1141.717.30	200	1 1/2	30x2.0	50.5	25.5	22.0	36	55	778

Fortsetzung nächste Seite

Continued on next page

Continuación página próxima

D1=Rohr außen-Ø
M1=metrisches Anschlußgewinde

D1=tube outside diameter
M1=metric connecting thread

D1=Ø exterior del tubo
M1=rosca métrica conexión

Gerade Einschraubverschraubungen

Abdichtung durch Dichtkante Form B nach DIN 3852-2

Straight male adaptor fittings

sealing edge form B acc. DIN 3852-2

Racores para roscar rectos

cierre hermético mediante borde de obturación forma B según DIN 3852-2

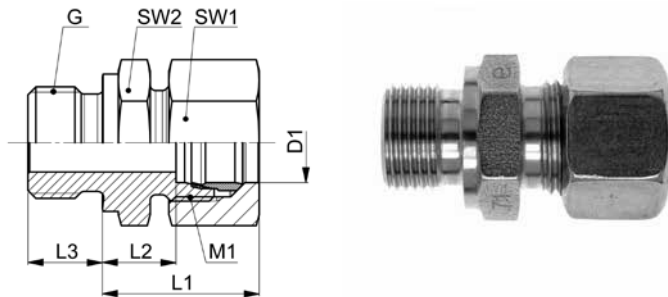

20

NC-GEV-..SR

Type-D1 G	Mat.-Nr.	PN	G	M1	L1	L2	L3	SW1	SW2	g/Stk
G=Rohrgewinde (zylindrisch)		G=BSP thread (parallel)				G=rosca de conexión (cilíndrica)				
NC-GEV-25SR 1.2	718.1141.800.30	100	1/2	36x2.0	47.0	20.0	14.0	46	41	444
NC-GEV-25SR 3.4	718.1141.805.30	100	3/4	36x2.0	50.0	23.0	16.0	46	41	455
NC-GEV-25SR 1.1	718.1141.810.30	100	1	36x2.0	50.0	23.0	18.0	46	41	494
NC-GEV-25SR 5.4	718.1141.815.30	100	1 1/4	36x2.0	50.0	23.0	20.0	46	50	674
NC-GEV-25SR 3.2	718.1141.820.30	100	1 1/2	36x2.0	53.0	26.0	22.0	46	55	582

Baumaße sind Ungefährmaße bei angezogener Überwurfmutter.

Sizes are approximate dimensions at tightened nut.

Las medidas son aproximadas con la tuerca de unión apretada.

D1=Rohr außen-Ø
M1=metrisches Anschlußgewinde

D1=tube outside diameter
M1=metric connecting thread

D1=Ø exterior del tubo
M1=rosca métrica conexión

Gerade Einschraubverschraubungen

Abdichtung durch Profildichtring Form E nach ISO 1179-2

Straight male adaptor fittings

profile sealing ring form E acc. ISO 1179-2

Racores para roscar rectos

cierre hermético mediante junta con perfil forma E según ISO 1179-2

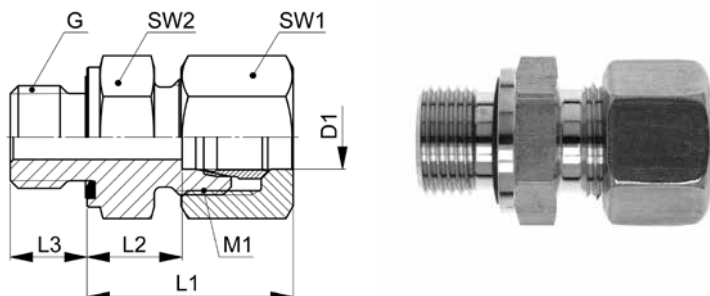

NC-GEV-..SR WD

Type-D1 G	Mat.-Nr.	PN	G	M1	L1	L2	L3	SW1	SW2	g/Stk
G=Rohrgewinde (zylindrisch)		G=BSP thread (parallel)				G=rosca de conexión (cilíndrica)				
NC-GEV-06SR 1.8 WD	718.1171.100.30	500	1/8	14x1.5	28.5	12.5	8.0	17	14	40
NC-GEV-06SR 1.4 WD	718.1171.110.30	500	1/4	14x1.5	29.0	13.0	12.0	17	19	54
NC-GEV-06SR 3.8 WD	718.1171.120.30	500	3/8	14x1.5	31.5	15.5	12.0	17	22	63
NC-GEV-06SR 1.2 WD	718.1171.125.30	500	1/2	14x1.5	34.0	18.0	14.0	17	27	107
NC-GEV-06SR 3.4 WD	718.1171.126.30	500	3/4	14x1.5	35.0	20.0	16.0	17	32	184
NC-GEV-08SR 1.8 WD	718.1171.160.30	500	1/8	16x1.5	30.5	14.5	8.0	19	17	57
NC-GEV-08SR 1.4 WD	718.1171.170.30	500	1/4	16x1.5	31.0	15.0	12.0	19	19	63
NC-GEV-08SR 3.8 WD	718.1171.180.30	500	3/8	16x1.5	31.5	15.5	12.0	19	22	82
NC-GEV-08SR 1.2 WD	718.1171.185.30	500	1/2	16x1.5	34.0	18.0	14.0	19	27	108
NC-GEV-10SR 1.8 WD	718.1171.265.30	400	1/8	18x1.5	32.5	14.0	8.0	22	19	48
NC-GEV-10SR 1.4 WD	718.1171.270.30	400	1/4	18x1.5	33.0	14.5	12.0	22	19	73
NC-GEV-10SR 3.8 WD	718.1171.280.30	400	3/8	18x1.5	34.5	15.0	12.0	22	22	89
NC-GEV-10SR 1.2 WD	718.1171.285.30	400	1/2	18x1.5	36.0	17.5	14.0	22	27	125
NC-GEV-10SR 3.4 WD	718.1171.290.30	400	3/4	18x1.5	38.0	19.5	16.0	22	32	166
NC-GEV-12SR 1.4 WD	718.1171.380.30	400	1/4	20x1.5	35.5	16.5	12.0	24	22	91
NC-GEV-12SR 3.8 WD	718.1171.390.30	400	3/8	20x1.5	36.0	17.0	12.0	24	22	100
NC-GEV-12SR 1.2 WD	718.1171.400.30	400	1/2	20x1.5	36.5	17.5	14.0	24	27	135
NC-GEV-12SR 3.4 WD	718.1171.405.30	400	3/4	20x1.5	36.5	17.5	16.0	24	32	192
NC-GEV-14SR 1.4 WD	718.1171.500.30	300	1/4	22x1.5	36.5	16.0	12.0	27	24	120
NC-GEV-14SR 3.8 WD	718.1171.502.30	300	3/8	22x1.5	39.0	18.5	12.0	27	24	130
NC-GEV-14SR 1.2 WD	718.1171.504.30	300	1/2	22x1.5	39.5	19.0	14.0	27	27	154
NC-GEV-14SR 3.4 WD	718.1171.506.30	300	3/4	22x1.5	41.5	21.0	16.0	27	32	195
NC-GEV-16SR 3.8 WD	718.1171.564.30	200	3/8	24x1.5	39.5	18.0	12.0	30	27	156
NC-GEV-16SR 1.2 WD	718.1171.566.30	200	1/2	24x1.5	40.0	18.5	14.0	30	27	161
NC-GEV-16SR 3.4 WD	718.1171.568.30	200	3/4	24x1.5	42.0	20.5	16.0	30	32	226
NC-GEV-16SR 1.1 WD	718.1171.570.30	200	1	24x1.5	44.0	22.5	18.0	30	41	348
NC-GEV-20SR 1.2 WD	718.1171.706.30	200	1/2	30x2.0	45.5	20.5	14.0	36	32	245
NC-GEV-20SR 3.4 WD	718.1171.708.30	200	3/4	30x2.0	45.5	20.5	16.0	36	32	277
NC-GEV-20SR 1.1 WD	718.1171.712.30	200	1	30x2.0	47.5	22.5	18.0	36	41	387
NC-GEV-20SR 5.4 WD	718.1171.715.30	200	1 1/4	30x2.0	47.5	22.5	20.0	36	50	574
NC-GEV-20SR 3.2 WD	718.1171.717.30	200	1 1/2	30x2.0	50.5	25.5	22.0	36	55	782

Fortsetzung nächste Seite

Continued on next page

Continuación página próxima

Gerade Einschraubverschraubungen

Abdichtung durch Profildichtring Form E nach ISO 1179-2

Straight male adaptor fittings

profile sealing ring form E acc. ISO 1179-2

Racores para roscar rectos

cierre hermético mediante junta con perfil forma E según ISO 1179-2

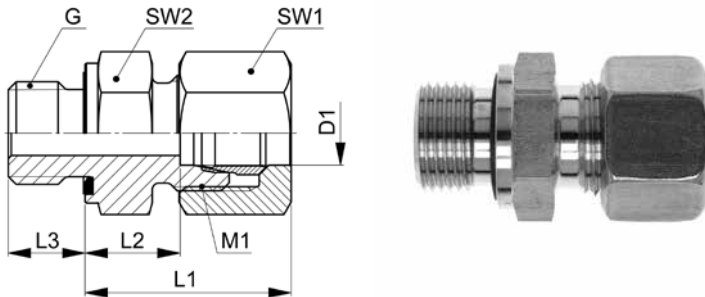

20

NC-GEV-..SR WD

Type-D1 G	Mat.-Nr.	PN	G	M1	L1	L2	L3	SW1	SW2	g/Stk
G=Rohrgewinde (zylindrisch)		G=BSP thread (parallel)				G=rosca de conexión (cilíndrica)				
NC-GEV-25SR 1.2 WD	718.1171.800.30	100	1/2	36x2.0	47.0	20.0	14.0	46	41	456
NC-GEV-25SR 3.4 WD	718.1171.805.30	100	3/4	36x2.0	50.0	23.0	16.0	46	41	455
NC-GEV-25SR 1.1 WD	718.1171.810.30	100	1	36x2.0	50.0	23.0	18.0	46	41	494
NC-GEV-25SR 5.4 WD	718.1171.815.30	100	1 1/4	36x2.0	50.0	23.0	20.0	46	50	674
NC-GEV-25SR 3.2 WD	718.1171.820.30	100	1 1/2	36x2.0	53.0	26.0	22.0	46	55	872

Baumaße sind Ungefährmaße bei angezogener Überwurfmutter.

Sizes are approximate dimensions at tightened nut.

Las medidas son aproximadas con la tuerca de unión apretada.

Dichtungsmaterial: FKM (andere Werkstoffe auf Anfrage)

Sealing material: FKM (other materials on request)

Material de junta tórica: FKM (otros materiales bajo demanda)

D1=Rohraußen-Ø
M1=metrisches Anschlußgewinde

D1=tube outside diameter
M1=metric connecting thread

D1=Ø exterior del tubo
M1=rosca métrica conexión

Gerade Einschraubverschraubungen

Abdichtung durch Dichtkante Form B nach DIN 3852-2

Straight male adaptor fittings

sealing edge form B acc. DIN 3852-2

Racores para roscar rectos

cierre hermético mediante borde de obturación forma B según DIN 3852-2

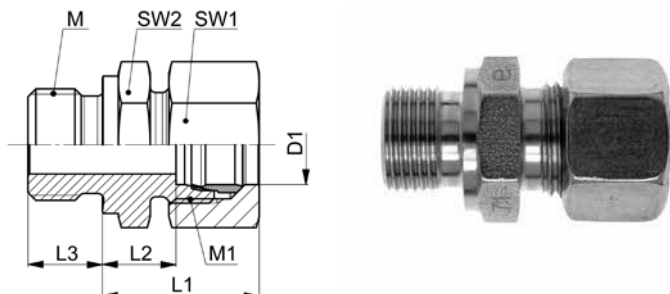

NC-GEV-..LM

Type-D1 M	Mat.-Nr.	PN	M	M1	L1	L2	L3	SW1	SW2	g/Stk
M=metrisches Gewinde (zylindrisch)	M=metric thread (parallel)	M=rosca métrica (cilíndrica)								
NC-GEV-06LM 10x1,0	718.1143.180.20	400	10x1.0	12x1.5	24.5	8.5	8.0	14	14	27
NC-GEV-06LM 12x1,5	718.1143.190.20	400	12x1.5	12x1.5	26.0	10.0	12.0	14	17	36
NC-GEV-08LM 12x1,5	718.1143.240.20	400	12x1.5	14x1.5	26.0	10.0	12.0	17	17	39
NC-GEV-08LM 14x1,5	718.1143.245.20	400	14x1.5	14x1.5	26.0	10.0	12.0	17	19	45
NC-GEV-08LM 18x1,5	718.1143.255.20	400	18x1.5	14x1.5	27.5	11.5	12.0	17	24	71
NC-GEV-10LM 10x1,0	718.1143.270.20	250	10x1.0	16x1.5	27.5	10.5	8.0	19	17	44
NC-GEV-10LM 12x1,5	718.1143.275.20	250	12x1.5	16x1.5	28.0	11.0	12.0	19	17	46
NC-GEV-10LM 14x1,5	718.1143.280.20	250	14x1.5	16x1.5	28.0	11.0	12.0	19	19	52
NC-GEV-10LM 16x1,5	718.1143.285.20	250	16x1.5	16x1.5	29.5	12.5	12.0	19	22	66
NC-GEV-10LM 18x1,5	718.1143.288.20	250	18x1.5	16x1.5	29.5	12.5	12.0	19	24	72
NC-GEV-10LM 22x1,5	718.1143.290.20	250	22x1.5	16x1.5	30.0	14.0	14.0	19	27	86
NC-GEV-12LM 14x1,5	718.1143.327.20	250	14x1.5	18x1.5	28.5	12.0	12.0	22	19	61
NC-GEV-12LM 16x1,5	718.1143.330.20	250	16x1.5	18x1.5	29.0	12.5	12.0	22	22	67
NC-GEV-12LM 18x1,5	718.1143.333.20	250	18x1.5	18x1.5	29.0	12.5	12.0	22	24	77
NC-GEV-12LM 22x1,5	718.1143.338.20	250	22x1.5	18x1.5	30.5	14.0	14.0	22	27	107
NC-GEV-15LM 18x1,5	718.1143.390.20	250	18x1.5	22x1.5	30.5	13.5	12.0	27	24	95
NC-GEV-15LM 22x1,5	718.1143.395.20	250	22x1.5	22x1.5	32.0	15.0	14.0	27	27	121
NC-GEV-18LM 18x1,5	718.1143.455.20	160	18x1.5	26x1.5	32.0	15.0	12.0	32	27	169
NC-GEV-18LM 22x1,5	718.1143.460.20	160	22x1.5	26x1.5	31.5	14.5	14.0	32	27	143
NC-GEV-18LM 26x1,5	718.1143.465.20	160	26x1.5	26x1.5	31.5	14.5	16.0	32	32	155
NC-GEV-22LM 22x1,5	718.1143.530.20	160	22x1.5	30x2.0	38.0	18.5	14.0	36	32	204
NC-GEV-22LM 18x1,5	718.1143.525.20	160	18x1.5	30x2.0	37.5	18.0	12.0	36	32	211
NC-GEV-22LM 26x1,5	718.1143.535.20	160	26x1.5	30x2.0	35.0	16.5	16.0	36	32	191

Baumaße sind Ungefährmaße bei angezogener Überwurfmutter.

Sizes are approximate dimensions at tightened nut.

Las medidas son aproximadas con la tuerca de unión apretada.

D1=Rohr außen-Ø
M1=metrisches Anschlußgewinde

D1=tube outside diameter
M1=metric connecting thread

D1=Ø exterior del tubo
M1=rosca métrica conexión

Gerade Einschraubverschraubungen

Abdichtung durch Profildichtring Form E nach ISO 1179-2

Straight male adaptor fittings

profile sealing ring form E acc. ISO 1179-2

Racores para roscar rectos

cierre hermético mediante junta con perfil forma E según ISO 1179-2

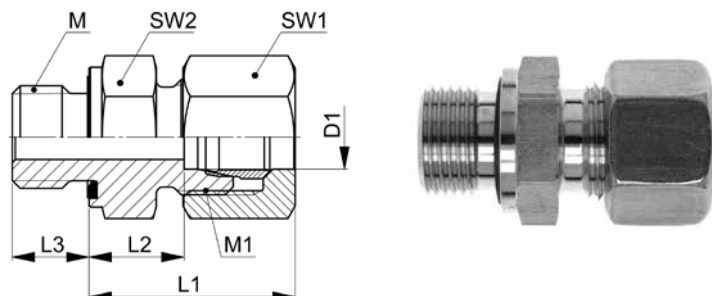

NC-GEV-..LM WD

Type-D1 M	Mat.-Nr.	PN	M	M1	L1	L2	L3	SW1	SW2	g/Stk
M=metrisches Gewinde (zylindrisch)		M=metric thread (parallel)				M=rosca métrica (cilíndrica)				
NC-GEV-06LM 10x1,0 WD	718.1173.180.20	400	10x1.0	12x1.5	24.5	8.5	8.0	14	14	24
NC-GEV-06LM 12x1,5 WD	718.1173.190.20	400	12x1.5	12x1.5	26.0	10.0	12.0	14	17	34
NC-GEV-08LM 12x1,5 WD	718.1173.240.20	400	12x1.5	14x1.5	26.0	10.0	12.0	17	17	37
NC-GEV-08LM 14x1,5 WD	718.1173.245.20	400	14x1.5	14x1.5	26.0	10.0	12.0	17	19	45
NC-GEV-08LM 18x1,5 WD	718.1173.255.20	400	18x1.5	14x1.5	27.5	11.5	12.0	17	24	79
NC-GEV-10LM 10x1,0 WD	718.1173.270.20	250	10x1.0	16x1.5	27.5	10.5	8.0	19	17	66
NC-GEV-10LM 12x1,5 WD	718.1173.275.20	250	12x1.5	16x1.5	28.0	11.0	12.0	19	17	46
NC-GEV-10LM 14x1,5 WD	718.1173.280.20	250	14x1.5	16x1.5	28.0	11.0	12.0	19	19	50
NC-GEV-10LM 16x1,5 WD	718.1173.285.20	250	16x1.5	16x1.5	29.5	12.5	12.0	19	22	64
NC-GEV-10LM 18x1,5 WD	718.1173.288.20	250	18x1.5	16x1.5	29.5	12.5	12.0	19	24	94
NC-GEV-10LM 22x1,5 WD	718.1173.290.20	250	22x1.5	16x1.5	32.0	14.0	14.0	19	27	86
NC-GEV-12LM 14x1,5 WD	718.1173.327.20	250	14x1.5	18x1.5	28.5	12.0	12.0	22	19	89
NC-GEV-12LM 16x1,5 WD	718.1173.330.20	250	16x1.5	18x1.5	29.0	12.5	12.0	22	22	67
NC-GEV-12LM 18x1,5 WD	718.1173.333.20	250	18x1.5	18x1.5	29.5	12.5	12.0	22	24	79
NC-GEV-12LM 22x1,5 WD	718.1173.338.20	250	22x1.5	18x1.5	30.5	14.0	14.0	22	27	117
NC-GEV-15LM 18x1,5 WD	718.1173.390.20	250	18x1.5	22x1.5	30.5	13.5	12.0	27	24	95
NC-GEV-15LM 22x1,5 WD	718.1173.395.20	250	22x1.5	22x1.5	32.0	15.0	14.0	27	27	121
NC-GEV-18LM 22x1,5 WD	718.1173.460.20	160	22x1.5	26x1.5	31.5	14.5	14.0	32	27	141
NC-GEV-18LM 26x1,5 WD	718.1173.465.20	160	26x1.5	26x1.5	31.5	14.5	14.0	32	32	169
NC-GEV-22LM 26x1,5 WD	718.1173.535.20	160	26x1.5	30x2.0	36.0	16.5	16.0	36	32	189

Baumaße sind Ungefährmaße bei angezogener Überwurfmutter.

Sizes are approximate dimensions at tightened nut.

Las medidas son aproximadas con la tuerca de unión apretada.

Dichtungsmaterial: FKM (andere Werkstoffe auf Anfrage)

Sealing material: FKM (other materials on request)

Material de junta tórica: FKM (otros materiales bajo demanda)

D1=Rohraußen-Ø
M1=metrisches Anschlußgewinde

D1=tube outside diameter
M1=metric connecting thread

D1=Ø exterior del tubo
M1=rosca métrica conexión

Gerade Einschraubverschraubungen

Abdichtung durch Dichtkante Form B nach DIN 3852-2

Straight male adaptor fittings

sealing edge form B acc. DIN 3852-2

Racores para roscar rectos

cierre hermético mediante borde de obturación forma B según DIN 3852-2

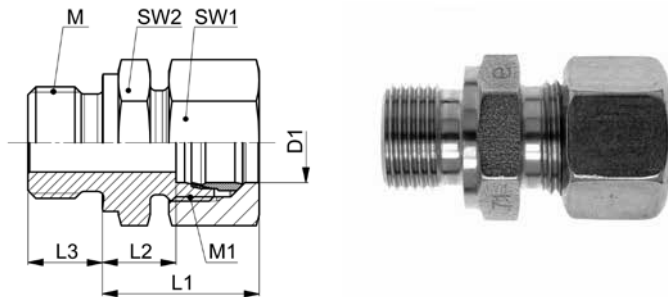

NC-GEV-..SM

Type-D1 M	Mat.-Nr.	PN	M	M1	L1	L2	L3	SW1	SW2	g/Stk
M=metrisches Gewinde (zylindrisch)		M=metric thread (parallel)				M=rosca métrica (cilíndrica)				
NC-GEV-06SM 12x1,5	718.1143.195.30	500	12x1.5	14x1.5	29.0	13.0	12.0	17	17	48
NC-GEV-06SM 14x1,5	718.1143.198.30	500	14x1.5	14x1.5	31.0	15.0	12.0	17	19	56
NC-GEV-08SM 14x1,5	718.1143.245.30	500	14x1.5	16x1.5	31.0	15.0	12.0	19	19	64
NC-GEV-10SM 16x1,5	718.1143.285.30	400	16x1.5	18x1.5	33.5	15.0	12.0	22	22	88
NC-GEV-12SM 14x1,5	718.1143.327.30	400	14x1.5	20x1.5	35.5	15.0	12.0	24	22	97
NC-GEV-12SM 18x1,5	718.1143.333.30	400	18x1.5	20x1.5	36.0	17.0	12.0	24	24	110
NC-GEV-14SM 20x1,5	718.1143.382.30	300	20x1.5	22x1.5	39.5	19.0	14.0	27	27	150
NC-GEV-16SM 22x1,5	718.1143.410.30	200	22x1.5	24x1.5	40.0	18.5	14.0	30	27	165
NC-GEV-20SM 27x2,0	718.1143.506.30	200	27x2.0	30x2.0	45.5	20.5	16.0	36	32	265
NC-GEV-25SM 33x2,0	718.1143.550.30	100	33x2.0	36x2.0	50.0	23.0	18.0	46	41	490

Baumaße sind Ungefährmaße bei angezogener Überwurfmutter.

Sizes are approximate dimensions at tightened nut.

Las medidas son aproximadas con la tuerca de unión apretada.

Gerade Einschraubverschraubungen

Abdichtung durch Profildichtring Form E nach ISO 1179-2

Straight male adaptor fittings

profile sealing ring form E acc. ISO 1179-2

Racores para roscar rectos

cierre hermético mediante junta con perfil forma E según ISO 1179-2

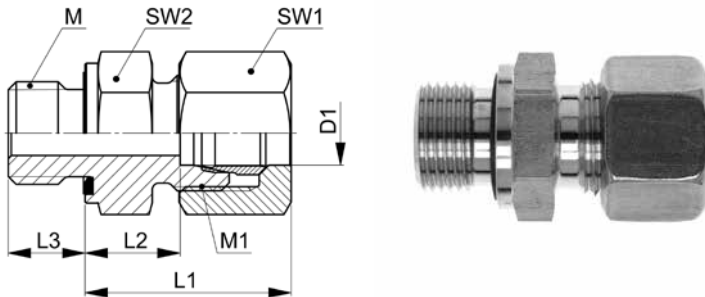

NC-GEV-..SM WD

Type-D1 M	Mat.-Nr.	PN	M	M1	L1	L2	L3	SW1	SW2	g/Stk
M=metrisches Gewinde (zylindrisch)		M=metric thread (parallel)				M=rosca métrica (cilíndrica)				
NC-GEV-06SM 12x1,5 WD	718.1173.195.30	500	12x1.5	14x1.5	29.0	13.0	12.0	17	17	48
NC-GEV-06SM 14x1,5 WD	718.1173.198.30	500	14x1.5	14x1.5	31.0	15.0	12.0	17	19	58
NC-GEV-08SM 14x1,5 WD	718.1173.245.30	500	14x1.5	16x1.5	31.0	15.0	12.0	19	19	62
NC-GEV-10SM 16x1,5 WD	718.1173.285.30	400	16x1.5	18x1.5	33.5	15.0	12.0	22	22	88
NC-GEV-12SM 14x1,5 WD	718.1173.327.30	400	14x1.5	20x1.5	35.5	16.5	12.0	24	22	90
NC-GEV-12SM 18x1,5 WD	718.1173.333.30	400	18x1.5	20x1.5	36.0	17.0	12.0	24	24	110
NC-GEV-14SM 20x1,5 WD	718.1173.382.30	300	20x1.5	22x1.5	39.5	19.0	14.0	27	27	150
NC-GEV-16SM 22x1,5 WD	718.1173.410.30	200	22x1.5	24x1.5	40.0	18.5	14.0	30	27	165
NC-GEV-20SM 27x2,0 WD	718.1173.506.30	200	27x2.0	30x2.0	45.5	20.5	16.0	36	32	265
NC-GEV-25SM 33x2,0 WD	718.1173.550.30	100	33x2.0	36x2.0	50.0	23.0	18.0	46	41	490

Baumaße sind Ungefährmaße bei angezogener Überwurfmutter.

Sizes are approximate dimensions at tightened nut.

Las medidas son aproximadas con la tuerca de unión apretada.

Dichtungsmaterial: FKM (andere Werkstoffe auf Anfrage)

Sealing material: FKM (other materials on request)

Material de junta tórica: FKM (otros materiales bajo demanda)

D1=Rohr außen-Ø
M1=metrisches Anschlußgewinde

D1=tube outside diameter
M1=metric connecting thread

D1=Ø exterior del tubo
M1=rosca métrica conexión

Gerade Einschraubverschraubungen

Abdichtung durch Kegeligwinde Form C nach DIN 3852-2

Straight male adaptor fittings

taper thread sealing form C acc. DIN 3852-2

Racores para roscar rectos

cierre hermético con rosca cónica forma C según DIN 3852-2

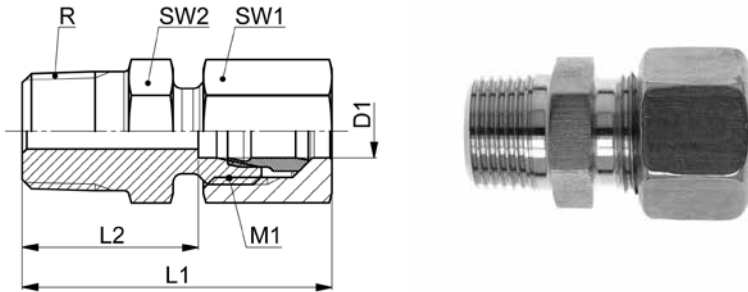

NC-GEV-..LRK

Type-D1 R	Mat.-Nr.	PN	R	M1	L1	L2	SW1	SW2	g/Stk
R=Rohrgewinde (kegelig)		R=BSP thread (tapered)				R=rosca para tubos (cónica)			
NC-GEV-06LRK 1.8	718.1101.100.20	315	1/8	12x1.5	32.0	16.0	14	12	28
NC-GEV-06LRK 1.4	718.1101.110.20	315	1/4	12x1.5	36.0	20.0	14	14	27
NC-GEV-06LRK 3.8	718.1101.120.20	315	3/8	12x1.5	35.0	19.0	14	19	34
NC-GEV-06LRK 1.2	718.1101.125.20	315	1/2	12x1.5	37.0	21.0	14	22	60
NC-GEV-08LRK 1.8	718.1101.160.20	315	1/8	14x1.5	32.0	16.0	17	14	32
NC-GEV-08LRK 1.4	718.1101.170.20	315	1/4	14x1.5	36.0	20.0	17	17	40
NC-GEV-08LRK 3.8	718.1101.180.20	315	3/8	14x1.5	36.0	20.0	17	19	46
NC-GEV-08LRK 1.2	718.1101.185.20	315	1/2	14x1.5	38.0	22.0	17	22	60
NC-GEV-10LRK 1.8	718.1101.265.20	250	1/8	16x1.5	34.5	17.0	19	17	38
NC-GEV-10LRK 1.4	718.1101.270.20	250	1/4	16x1.5	38.5	21.0	19	17	44
NC-GEV-10LRK 3.8	718.1101.280.20	250	3/8	16x1.5	38.5	21.0	19	17	57
NC-GEV-10LRK 1.2	718.1101.285.20	250	1/2	16x1.5	40.5	23.0	19	22	70
NC-GEV-12LRK 1.4	718.1101.380.20	250	1/4	18x1.5	39.0	22.0	27	19	58
NC-GEV-12LRK 3.8	718.1101.390.20	250	3/8	18x1.5	39.0	22.0	22	19	62
NC-GEV-12LRK 1.2	718.1101.400.20	250	1/2	18x1.5	41.5	24.5	22	22	80
NC-GEV-15LRK 3.8	718.1101.532.20	250	3/8	22x1.5	41.0	23.0	27	24	94
NC-GEV-15LRK 1.2	718.1101.534.20	250	1/2	22x1.5	43.0	25.0	27	24	105
NC-GEV-18LRK 1.2	718.1101.646.20	160	1/2	26x1.5	43.0	25.5	32	27	145
NC-GEV-18LRK 3.4	718.1101.648.20	160	3/4	26x1.5	45.0	27.5	32	27	162
NC-GEV-22LRK 1.2	718.1101.764.20	160	1/2	30x2.0	47.5	27.5	36	32	188
NC-GEV-22LRK 3.4	718.1101.768.20	160	3/4	30x2.0	49.5	29.5	36	32	192

Druckangaben gelten in Verbindung mit zylindrischem Innengewinde.

Pressure information applies in connection with parallel female thread.

Datos de presión válidos en combinación con roscas interiores cilíndricas.

Baumaße sind Ungefährmaße bei angezogener Überwurfmutter.

Sizes are approximate dimensions at tightened nut.

Las medidas son aproximadas con la tuerca de unión apretada.

D1=Rohr außen-Ø
M1=metrisches Anschlußgewinde

D1=tube outside diameter
M1=metric connecting thread

D1=Ø exterior del tubo
M1=rosca métrica conexión

Gerade Einschraubverschraubungen

Abdichtung durch Kegelfgewinde Form C nach DIN 3852-2

Straight male adaptor fittings

taper thread sealing form C acc. DIN 3852-2

Racores para roscar rectos

cierre hermético con rosca cónica forma C según DIN 3852-2

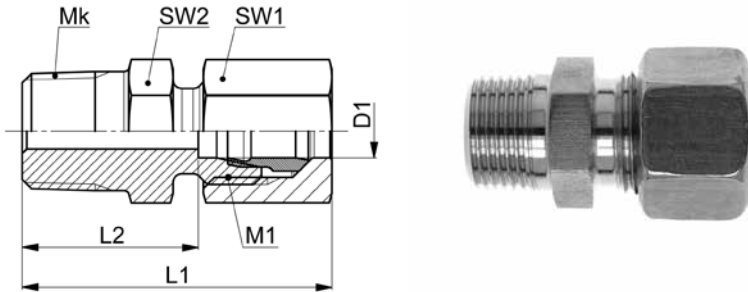

NC-GEV-..LMK

Type-D1 Mk	Mat.-Nr.	PN	Mk	M1	L1	L2	SW1	SW2	g/Stk
Mk=metrisches Gewinde (kegelig)		Mk=metric thread (tapered)				Mk=rosca métrica (cónica)			
NC-GEV-06LMK 08x1,0	718.1103.170.20	315	08x1.0	12x1.5	31.0	16.0	14	12	22
NC-GEV-06LMK 10x1,0	718.1103.180.20	315	10x1.0	12x1.5	32.0	16.0	14	14	26
NC-GEV-06LMK 12x1,5	718.1103.195.20	315	12x1.5	12x1.5	36.0	20.0	14	14	32
NC-GEV-08LMK 12x1,5	718.1103.240.20	315	12x1.5	14x1.5	36.0	20.0	17	14	35
NC-GEV-08LMK 14x1,5	718.1103.245.20	315	14x1.5	14x1.5	36.0	20.0	17	17	39
NC-GEV-10LMK 14x1,5	718.1103.280.20	250	14x1.5	16x1.5	38.0	21.0	19	17	46
NC-GEV-10LMK 16x1,5	718.1103.285.20	250	16x1.5	16x1.5	38.0	21.0	19	17	50
NC-GEV-12LMK 16x1,5	718.1103.330.20	250	16x1.5	18x1.5	38.5	22.0	22	19	59
NC-GEV-12LMK 18x1,5	718.1103.333.20	250	18x1.5	18x1.5	38.5	22.0	22	19	77
NC-GEV-15LMK 18x1,5	718.1103.390.20	250	18x1.5	22x1.5	40.0	23.0	27	24	91
NC-GEV-18LMK 22x1,5	718.1103.460.20	160	22x1.5	26x1.5	42.5	25.5	32	27	156

Druckangaben gelten in Verbindung mit zylindrischem Innengewinde.

Pressure information applies in connection with parallel female thread.

Datos de presión válidos en combinación con roscas interiores cilíndricas.

Baumaße sind Ungefährmaße bei angezogener Überwurfmutter.

Sizes are approximate dimensions at tightened nut.

Las medidas son aproximadas con la tuerca de unión apretada.

D1=Rohr außen-Ø
M1=metrisches Anschlußgewinde

D1=tube outside diameter
M1=metric connecting thread

D1=Ø exterior del tubo
M1=rosca métrica conexión

Gerade Einschraubverschraubungen NPT
Straight male adaptor fittings NPT
Racores para roscar rectos NPT

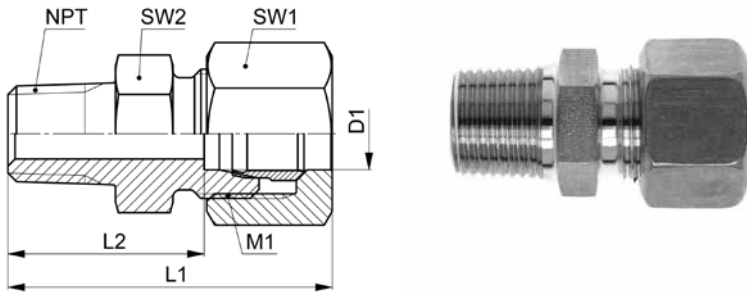

NC-GEV-..LNPT

Type-D1 NPT	Mat.-Nr.	PN	NPT	M1	L1	L2	SW1	SW2	g/Stk
NPT=Einschraubgewinde NPT NPT=tapered male adaptor thread NPT NPT=rosca de conexión cónica NPT									
NC-GEV-06LNPT 1.8	718.1102.100.20	400	1/8	12x1.5	33.0	17.0	14	12	25
NC-GEV-06LNPT 1.4	718.1102.110.20	400	1/4	12x1.5	39.0	23.0	14	17	42
NC-GEV-06LNPT 3.8	718.1102.120.20	400	3/8	12x1.5	40.0	24.0	14	19	51
NC-GEV-06LNPT 1.2	718.1102.125.20	400	1/2	12x1.5	45.0	29.0	14	22	82
NC-GEV-08LNPT 1.8	718.1102.160.20	400	1/8	14x1.5	34.0	18.0	17	14	37
NC-GEV-08LNPT 1.4	718.1102.170.20	400	1/4	14x1.5	39.0	23.0	17	17	43
NC-GEV-08LNPT 3.8	718.1102.180.20	400	3/8	14x1.5	40.0	24.0	17	19	60
NC-GEV-08LNPT 1.2	718.1102.185.20	400	1/2	14x1.5	45.0	29.0	17	22	85
NC-GEV-10LNPT 1.8	718.1102.265.20	250	1/8	16x1.5	36.0	19.0	19	17	40
NC-GEV-10LNPT 1.4	718.1102.270.20	250	1/4	16x1.5	41.0	24.0	19	17	55
NC-GEV-10LNPT 3.8	718.1102.280.20	250	3/8	16x1.5	42.0	25.0	19	19	65
NC-GEV-10LNPT 1.2	718.1102.285.20	250	1/2	16x1.5	47.0	30.0	19	22	85
NC-GEV-10LNPT 3.4	718.1102.290.20	250	3/4	16x1.5	48.0	31.0	19	27	120
NC-GEV-12LNPT 1.8	718.1102.375.20	250	1/8	18x1.5	36.5	20.0	22	19	56
NC-GEV-12LNPT 1.4	718.1102.380.20	250	1/4	18x1.5	41.5	25.0	22	19	59
NC-GEV-12LNPT 3.8	718.1102.390.20	250	3/8	18x1.5	41.5	25.0	22	19	66
NC-GEV-12LNPT 1.2	718.1102.400.20	250	1/2	18x1.5	46.5	30.0	22	22	89
NC-GEV-12LNPT 3.4	718.1102.405.20	250	3/4	18x1.5	47.5	31.0	22	27	134
NC-GEV-15LNPT 1.4	718.1102.528.20	250	1/4	22x1.5	43.0	26.0	27	24	90
NC-GEV-15LNPT 3.8	718.1102.532.20	250	3/8	22x1.5	43.0	26.0	27	24	96
NC-GEV-15LNPT 1.2	718.1102.534.20	250	1/2	22x1.5	48.0	31.0	27	24	115
NC-GEV-15LNPT 3.4	718.1102.536.20	250	3/4	22x1.5	49.0	32.0	27	27	154
NC-GEV-15LNPT 1.1	718.1102.541.20	250	1	22x1.5	55.0	38.0	27	36	178
NC-GEV-18LNPT 3.8	718.1102.644.20	160	3/8	26x1.5	43.5	26.5	32	27	138
NC-GEV-18LNPT 1.2	718.1102.646.20	160	1/2	26x1.5	48.5	31.5	32	27	135
NC-GEV-18LNPT 3.4	718.1102.648.20	160	3/4	26x1.5	48.5	31.5	32	27	170
NC-GEV-18LNPT 1.1	718.1102.652.20	160	1	26x1.5	54.5	37.5	32	36	262
NC-GEV-22LNPT 3.8	718.1102.763.20	160	3/8	30x2.0	48.0	28.5	36	32	200
NC-GEV-22LNPT 1.2	718.1102.764.20	160	1/2	30x2.0	53.0	33.5	36	32	194
NC-GEV-22LNPT 3.4	718.1102.768.20	160	3/4	30x2.0	53.0	33.5	36	32	196
NC-GEV-22LNPT 1.1	718.1102.770.20	160	1	30x2.0	59.0	39.5	36	36	282

Baumaße sind Ungefährmaße bei angezogener Überwurfmutter.

Sizes are approximate dimensions at tightened nut.

Las medidas son aproximadas con la tuerca de unión apretada.

D1=Rohr außen-Ø
M1=metrisches Anschlußgewinde

D1=tube outside diameter
M1=metric connecting thread

D1=Ø exterior del tubo
M1=rosca métrica conexión

Gerade Einschraubverschraubungen NPT
Straight male adaptor fittings NPT
Racores para roscar rectos NPT

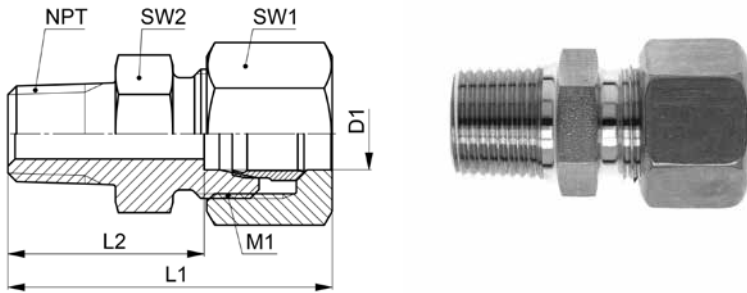

20

NC-GEV-..SNPT

Type-D1 NPT	Mat.-Nr.	PN	NPT	M1	L1	L2	SW1	SW2	g/Stk
NPT=Einschraubgewinde NPT NPT=tapered male adaptor thread NPT NPT=rosca de conexión cónica NPT									
NC-GEV-06SNPT 1.8	718.1102.100.30	500	1/8	14x1.5	36.0	21.0	17	14	45
NC-GEV-06SNPT 1.4	718.1102.110.30	500	1/4	14x1.5	44.0	28.0	17	17	55
NC-GEV-06SNPT 3.8	718.1102.120.30	500	3/8	14x1.5	44.0	28.0	17	19	70
NC-GEV-06SNPT 1.2	718.1102.125.30	500	1/2	14x1.5	51.0	35.0	17	22	93
NC-GEV-08SNPT 1.8	718.1102.160.30	500	1/8	16x1.5	39.0	23.0	19	17	48
NC-GEV-08SNPT 1.4	718.1102.170.30	500	1/4	16x1.5	44.0	28.0	19	17	60
NC-GEV-08SNPT 3.8	718.1102.180.30	500	3/8	16x1.5	44.0	28.0	19	19	74
NC-GEV-08SNPT 1.2	718.1102.185.30	500	1/2	16x1.5	51.0	35.0	19	22	108
NC-GEV-10SNPT 1.4	718.1102.270.30	400	1/4	18x1.5	46.0	27.5	22	19	71
NC-GEV-10SNPT 3.8	718.1102.280.30	400	3/8	18x1.5	46.0	27.5	22	19	86
NC-GEV-10SNPT 1.2	718.1102.285.30	400	1/2	18x1.5	53.0	34.5	22	22	104
NC-GEV-10SNPT 3.4	718.1102.290.30	400	3/4	18x1.5	53.0	34.5	22	27	154
NC-GEV-12SNPT 1.4	718.1102.380.30	400	1/4	20x1.5	48.5	29.5	24	22	96
NC-GEV-12SNPT 3.8	718.1102.390.30	400	3/8	20x1.5	48.5	29.5	24	22	100
NC-GEV-12SNPT 1.2	718.1102.400.30	400	1/2	20x1.5	53.5	34.5	24	22	121
NC-GEV-12SNPT 3.4	718.1102.405.30	400	3/4	20x1.5	53.5	34.5	24	27	170
NC-GEV-14SNPT 3.8	718.1102.502.30	300	3/8	22x1.5	51.5	31.0	27	24	125
NC-GEV-14SNPT 1.2	718.1102.504.30	300	1/2	22x1.5	56.5	36.0	27	24	160
NC-GEV-14SNPT 3.4	718.1102.506.30	300	3/4	22x1.5	56.5	36.0	27	27	180
NC-GEV-14SNPT 1.1	718.1102.510.30	300	1	22x1.5	63.5	43.0	27	36	230
NC-GEV-16SNPT 3.8	718.1102.564.30	200	3/8	24x1.5	52.0	30.5	30	27	152
NC-GEV-16SNPT 1.2	718.1102.566.30	200	1/2	24x1.5	57.0	35.5	30	27	170
NC-GEV-16SNPT 3.4	718.1102.568.30	200	3/4	24x1.5	57.0	35.5	30	27	196
NC-GEV-16SNPT 1.1	718.1102.570.30	200	1	24x1.5	64.0	42.5	30	36	324
NC-GEV-20SNPT 1.2	718.1102.706.30	200	1/2	30x2.0	62.5	37.5	36	32	246
NC-GEV-20SNPT 3.4	718.1102.708.30	200	3/4	30x2.0	62.5	37.5	36	32	268
NC-GEV-20SNPT 1.1	718.1102.712.30	200	1	30x2.0	67.5	42.5	36	36	360
NC-GEV-25SNPT 1.2	718.1102.800.30	100	1/2	36x2.0	67.5	40.0	46	41	421
NC-GEV-25SNPT 3.4	718.1102.805.30	100	3/4	36x2.0	67.0	40.0	46	41	474
NC-GEV-25SNPT 1.1	718.1102.810.30	100	1	36x2.0	72.0	45.0	46	41	503
NC-GEV-25SNPT 5.4	718.1102.815.30	100	1 1/4	36x2.0	73.0	46.0	46	46	654
NC-GEV-25SNPT 3.2	718.1102.820.30	100	1 1/2	36x2.0	73.0	46.0	46	50	714

Baumaße sind Ungefährmaße bei angezogener Überwurfmutter.

Sizes are approximate dimensions at tightened nut.

Las medidas son aproximadas con la tuerca de unión apretada.

D1=Rohr außen-Ø
M1=metrisches Anschlußgewinde

D1=tube outside diameter
M1=metric connecting thread

D1=Ø exterior del tubo
M1=rosca métrica conexión

Winkel-Einschraubverschraubungen

Abdichtung durch Dichtkante Form B nach DIN 3852-2

Male adaptor elbow fittings

sealing edge form B acc. DIN 3852-2

Racores para roscar en codo

cierre hermético mediante borde de obturación forma B según DIN 3852-2

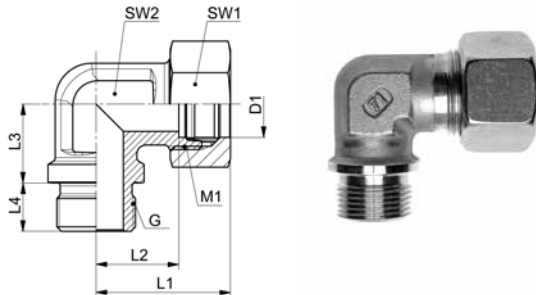

NC-WEV-..LR/SR

Type-D1 G	Mat.-Nr.	PN	G	M1	L1	L2	L3	L4	SW1	SW2	g/Stk
G=Rohrgewinde (zylindrisch)		G=BSP thread (parallel)					G=rosca de conexión (cilíndrica)				
NC-WEV-22LR 3.4	718.2406.768.20	160	3/4	30x2.0	47.0	27.5	26.0	16.0	36	27	267
NC-WEV-20SR 3.4	718.2406.704.30	200	3/4	30x2.0	51.5	26.5	26.0	16.0	36	27	329
NC-WEV-25SR 1.1	718.2406.810.30	100	1	36x2.0	57.0	30.0	30.0	18.0	46	36	631

Baumaße sind Ungefährmaße bei angezogener Überwurfmutter.

Sizes are approximate dimensions at tightened nut.

Las medidas son aproximadas con la tuerca de unión apretada.

Winkel-Einschraubverschraubungen

Abdichtung im Kegengewinde Form C nach DIN 3852-2

Male adaptor elbow fittings

taper thread sealing form C acc. DIN 3852-2

Racores para roscar en codo

cierre hermético con rosca cónica forma C según DIN 3852-2

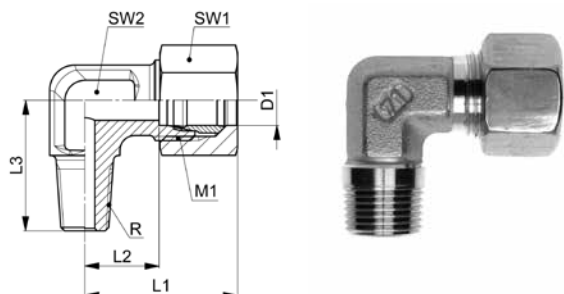

20

NC-WEV-..LRK

Type-D1 R	Mat.-Nr.	PN	R	M1	L1	L2	L3	SW1	SW2	g/Stk
R=Rohrgewinde (kegelig)		R=BSP thread (tapered)								
										R=rosca para tubos (cónica)
NC-WEV-06LRK 1.8	718.2401.100.20	400	1/8	12x1.5	28.0	12.0	20.0	14	12	34
NC-WEV-06LRK 1.4	718.2401.110.20	400	1/4	12x1.5	28.0	12.0	26.0	14	12	57
NC-WEV-06LRK 3.8	718.2401.120.20	400	3/8	12x1.5	30.0	14.0	28.0	14	14	58
NC-WEV-08LRK 1.8	718.2401.160.20	400	1/8	14x1.5	30.0	14.0	26.0	17	12	53
NC-WEV-08LRK 1.4	718.2401.170.20	400	1/4	14x1.5	30.0	14.0	26.0	17	12	60
NC-WEV-08LRK 3.8	718.2401.180.20	400	3/8	14x1.5	31.0	15.0	27.0	17	14	82
NC-WEV-08LRK 1.2	718.2401.185.20	400	1/2	14x1.5	35.0	19.0	30.0	17	17	95
NC-WEV-10LRK 1.8	718.2401.265.20	250	1/8	16x1.5	32.5	15.0	26.0	19	14	64
NC-WEV-10LRK 1.4	718.2401.270.20	250	1/4	16x1.5	32.5	15.0	27.0	19	14	66
NC-WEV-10LRK 3.8	718.2401.280.20	250	3/8	16x1.5	32.5	15.0	27.0	19	14	70
NC-WEV-10LRK 1.2	718.2401.285.20	250	1/2	16x1.5	38.5	21.0	32.0	19	19	90
NC-WEV-12LRK 1.4	718.2401.380.20	250	1/4	18x1.5	34.0	17.0	28.0	22	17	74
NC-WEV-12LRK 3.8	718.2401.390.20	250	3/8	18x1.5	34.0	17.0	28.0	22	17	75
NC-WEV-12LRK 1.2	718.2401.400.20	250	1/2	18x1.5	38.0	21.0	32.0	22	19	110
NC-WEV-15LRK 3.8	718.2401.532.20	250	3/8	22x1.5	39.0	21.0	28.0	27	19	134
NC-WEV-15LRK 1.2	718.2401.534.20	250	1/2	22x1.5	39.5	21.0	34.0	27	19	216
NC-WEV-18LRK 1.2	718.2401.646.20	160	1/2	26x1.5	41.0	23.5	36.0	32	24	273
NC-WEV-18LRK 3.4	718.2401.648.20	160	3/4	26x1.5	41.0	23.5	34.0	32	24	233
NC-WEV-22LRK 3.4	718.2401.768.20	160	3/4	30x2.0	47.5	27.5	42.0	36	27	295

Druckangaben gelten in Verbindung mit zylindrischem Innengewinde.

Pressure information applies in connection with parallel female thread.

Datos de presión válidos en combinación con roscas interiores cilíndricas.

Baumaße sind Ungefährmaße bei angezogener Überwurfmutter.

Sizes are approximate dimensions at tightened nut.

Las medidas son aproximadas con la tuerca de unión apretada.

D1=Rohr außen-Ø
M1=metrisches Anschlußgewinde

D1=tube outside diameter
M1=metric connecting thread

D1=Ø exterior del tubo
M1=rosca métrica conexión

Winkel-Einschraubverschraubungen

Abdichtung im Kegelgewinde Form C nach DIN 3852-2

Male adaptor elbow fittings

taper thread sealing form C acc. DIN 3852-2

Racores para roscar en codo

cierre hermético con rosca cónica forma C según DIN 3852-2

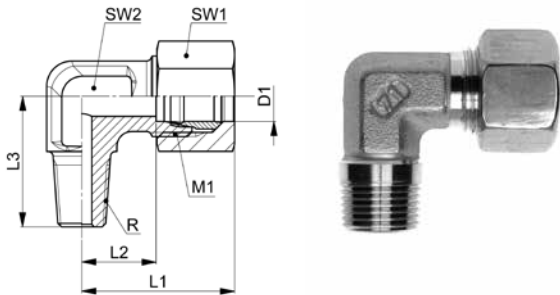

NC-WEV-..SRK

Type-D1 R	Mat.-Nr.	PN	R	M1	L1	L2	L3	SW1	SW2	g/Stk
R=Rohrgewinde (kegelig)		R=BSP thread (tapered)				R=rosca para tubos (cónica)				
NC-WEV-06SRK 1.8	718.2401.100.30	500	1/8	14x1.5	32.0	16.0	26.0	17	12	59
NC-WEV-06SRK 1.4	718.2401.110.30	500	1/4	14x1.5	32.0	16.0	26.0	17	12	61
NC-WEV-06SRK 3.8	718.2401.120.30	500	3/8	14x1.5	32.0	16.0	28.0	17	14	80
NC-WEV-06SRK 1.2	718.2401.125.30	500	1/2	14x1.5	32.0	16.0	30.0	17	17	101
NC-WEV-08SRK 1.4	718.2401.170.30	500	1/4	16x1.5	33.0	17.0	27.0	19	14	79
NC-WEV-08SRK 3.8	718.2401.180.30	500	3/8	16x1.5	33.0	17.0	27.0	19	14	85
NC-WEV-08SRK 1.2	718.2401.185.30	500	1/2	16x1.5	35.0	19.0	30.0	19	17	102
NC-WEV-10SRK 1.4	718.2401.270.30	400	1/4	18x1.5	36.5	17.5	27.0	22	17	92
NC-WEV-10SRK 3.8	718.2401.280.30	400	3/8	18x1.5	36.5	17.5	28.0	22	17	95
NC-WEV-10SRK 1.2	718.2401.285.30	400	1/2	18x1.5	36.5	17.5	32.0	22	17	131
NC-WEV-12SRK 3.8	718.2401.390.30	400	3/8	20x1.5	41.0	21.5	28.0	24	17	115
NC-WEV-12SRK 1.2	718.2401.400.30	400	1/2	20x1.5	41.0	21.5	32.0	24	17	130
NC-WEV-14SRK 3.8	718.2401.502.30	300	3/8	22x1.5	43.0	22.0	32.0	27	19	147
NC-WEV-14SRK 1.2	718.2401.504.30	300	1/2	22x1.5	43.0	22.0	32.0	27	19	158
NC-WEV-16SRK 1.2	718.2401.566.30	200	1/2	24x1.5	47.0	24.5	32.0	30	24	200

Druckangaben gelten in Verbindung mit zylindrischem Innengewinde.

Pressure information applies in connection with parallel female thread.

Datos de presión válidos en combinación con roscas interiores cilíndricas.

Baumaße sind Ungefährmaße bei angezogener Überwurfmutter.

Sizes are approximate dimensions at tightened nut.

Las medidas son aproximadas con la tuerca de unión apretada.

D1=Rohr außen-Ø
M1=metrisches Anschlußgewinde

D1=tube outside diameter
M1=metric connecting thread

D1=Ø exterior del tubo
M1=rosca métrica conexión

Winkel-Einschraubverschraubungen

Abdichtung im Kegengewinde Form C nach DIN 3852-2

Male adaptor elbow fittings

taper thread sealing form C acc. DIN 3852-2

Racores para roscar en codo

cierre hermético con rosca cónica forma C según DIN 3852-2

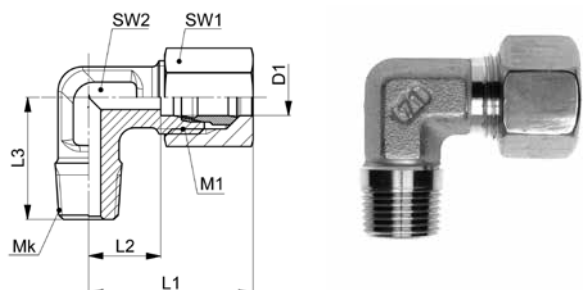

20

NC-WEV-..LMK/SMK

Type-D1 Mk	Mat.-Nr.	PN	Mk	M1	L1	L2	L3	SW1	SW2	g/Stk
Mk=metrisches Gewinde (kegelig)		Mk=metric thread (tapered)								
										Mk=rosca métrica (cónica)
NC-WEV-06LMK 10x1,0	718.2403.180.20	400	10x1.0	12x1.5	28.0	12.0	20.0	14	12	32
NC-WEV-08LMK 12x1,5	718.2403.240.20	400	10x1.0	14x1.5	30.0	14.0	26.0	17	12	43
NC-WEV-10LMK 14x1,5	718.2403.278.20	250	14x1.5	16x1.5	32.5	15.0	27.0	19	14	61
NC-WEV-12LMK 16x1,5	718.2403.330.20	250	16x1.5	18x1.5	34.0	17.0	28.0	22	17	80
NC-WEV-15LMK 18x1,5	718.2403.390.20	250	18x1.5	22x1.5	39.0	21.0	32.0	27	19	136
NC-WEV-18LMK 22x1,5	718.2403.460.20	160	22x1.5	26x1.5	41.0	23.5	36.0	32	24	188
NC-WEV-06SMK 12x1,5	718.2403.190.30	500	12x1.5	14x1.5	32.0	16.0	26.0	17	12	55
NC-WEV-08SMK 14x1,5	718.2403.245.30	500	14x1.5	16x1.5	33.0	17.0	27.0	19	14	70
NC-WEV-10SMK 16x1,5	718.2403.285.30	400	16x1.5	18x1.5	36.5	17.5	28.0	22	17	98
NC-WEV-12SMK 18x1,5	718.2403.333.30	400	18x1.5	20x1.5	41.0	21.5	28.0	24	17	118
NC-WEV-14SMK 20x1,5	718.2403.382.30	300	20x1.5	22x1.5	43.0	22.0	32.0	27	19	154

Druckangaben gelten in Verbindung mit zylindrischem Innengewinde.

Pressure information applies in connection with parallel female thread.

Datos de presión válidos en combinación con roscas interiores cilíndricas.

Baumaße sind Ungefährmaße bei angezogener Überwurfmutter.

Sizes are approximate dimensions at tightened nut.

Las medidas son aproximadas con la tuerca de unión apretada.

D1=Rohr außen-Ø
M1=metrisches Anschlußgewinde

D1=tube outside diameter
M1=metric connecting thread

D1=Ø exterior del tubo
M1=rosca métrica conexión

Winkel-Einschraubverschraubungen NPT
Male adaptor elbow fittings NPT
Racores para roscar en codo NPT

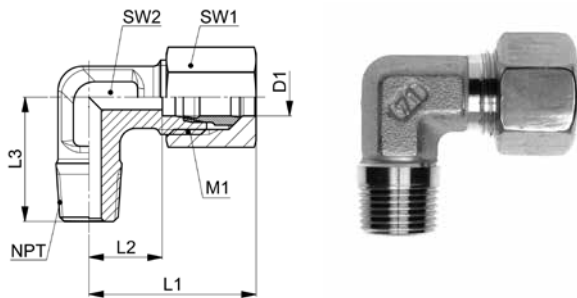

NC-WEV-..LNPT

Type-D1 NPT	Mat.-Nr.	PN	NPT	M1	L1	L2	L3	SW1	SW2	g/Stk
NPT=Einschraubgewinde NPT		NPT=tapered male adaptor thread NPT			NPT=rosca de conexión cónica NPT					
NC-WEV-06LNPT 1.8	718.2402.100.20	400	1/8	12x1.5	28.0	12.0	20.0	14	12	32
NC-WEV-06LNPT 1.4	718.2402.110.20	400	1/4	12x1.5	26.0	12.0	26.0	14	12	36
NC-WEV-06LNPT 3.8	718.2402.120.20	400	3/8	12x1.5	30.0	14.0	28.0	14	14	52
NC-WEV-08LNPT 1.8	718.2402.160.20	400	1/8	14x1.5	30.0	14.0	24.0	17	12	42
NC-WEV-08LNPT 1.4	718.2402.170.20	400	1/4	14x1.5	30.0	14.0	26.0	17	12	44
NC-WEV-08LNPT 3.8	718.2402.180.20	400	3/8	14x1.5	31.0	15.0	28.0	17	14	71
NC-WEV-08LNPT 1.2	718.2402.185.20	400	1/2	14x1.5	35.0	19.0	34.0	17	17	104
NC-WEV-10LNPT 1.4	718.2402.270.20	250	1/4	16x1.5	32.0	15.0	26.0	19	14	56
NC-WEV-10LNPT 3.8	718.2402.280.20	250	3/8	16x1.5	32.0	15.0	28.0	19	14	60
NC-WEV-10LNPT 1.2	718.2402.285.20	250	1/2	16x1.5	38.5	21.0	30.0	19	17	100
NC-WEV-12LNPT 1.4	718.2402.380.20	250	1/4	18x1.5	33.5	17.0	26.0	22	17	76
NC-WEV-12LNPT 3.8	718.2402.390.20	250	3/8	18x1.5	33.5	17.0	28.0	22	17	76
NC-WEV-12LNPT 1.2	718.2402.400.20	250	1/2	18x1.5	38.0	21.0	34.0	22	17	118
NC-WEV-15LNPT 1.2	718.2402.534.20	250	1/2	22x1.5	38.0	21.0	34.0	27	19	138
NC-WEV-18LNPT 1.2	718.2402.646.20	160	1/2	26x1.5	40.5	23.5	36.0	32	24	184
NC-WEV-18LNPT 3.4	718.2402.648.20	160	3/4	26x1.5	40.5	23.5	36.0	32	24	200
NC-WEV-22LNPT 3.4	718.2402.768.20	160	3/4	30x2.0	47.0	27.5	42.0	36	27	252

Baumaße sind Ungefährmaße bei angezogener Überwurfmutter.

Sizes are approximate dimensions at tightened nut.

Las medidas son aproximadas con la tuerca de unión apretada.

D1=Rohr außen-Ø
M1=metrisches Anschlußgewinde

D1=tube outside diameter
M1=metric connecting thread

D1=Ø exterior del tubo
M1=rosca métrica conexión

Winkel-Einschraubverschraubungen NPT
Male adaptor elbow fittings NPT
Racores para roscar en codo NPT

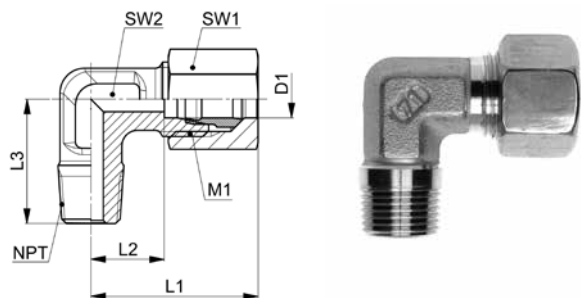

20

NC-WEV-..SNPT

Type-D1 NPT	Mat.-Nr.	PN	NPT	M1	L1	L2	L3	SW1	SW2	g/Stk
NPT=Einschraubgewinde NPT		NPT=tapered male adaptor thread NPT			NPT=rosca de conexión cónica NPT					
NC-WEV-06SNPT 1.4	718.2402.110.30	500	1/4	14x1.5	32.0	16.0	26.0	17	12	54
NC-WEV-06SNPT 3.8	718.2402.120.30	500	3/8	14x1.5	32.0	16.0	28.0	17	14	70
NC-WEV-06SNPT 1.2	718.2402.125.30	500	1/2	14x1.5	32.0	16.0	33.0	17	17	99
NC-WEV-08SNPT 1.4	718.2402.170.30	500	1/4	16x1.5	33.0	17.0	26.0	19	14	68
NC-WEV-08SNPT 3.8	718.2402.180.30	500	3/8	16x1.5	34.0	18.0	28.0	19	17	76
NC-WEV-08SNPT 1.2	718.2402.185.30	500	1/2	16x1.5	37.0	21.0	34.0	19	17	133
NC-WEV-10SNPT 1.4	718.2402.270.30	400	1/4	18x1.5	36.5	17.5	26.0	22	17	88
NC-WEV-10SNPT 3.8	718.2402.280.30	400	3/8	18x1.5	36.5	17.5	28.0	22	17	98
NC-WEV-12SNPT 1.4	718.2402.380.30	400	1/4	20x1.5	40.5	21.5	27.0	24	17	104
NC-WEV-12SNPT 1.2	718.2402.400.30	400	1/2	20x1.5	41.5	21.5	33.0	24	17	132
NC-WEV-12SNPT 3.8	718.2402.390.30	400	3/8	20x1.5	40.5	21.5	28.0	24	17	112
NC-WEV-14SNPT 3.8	718.2402.502.30	300	3/8	22x1.5	43.0	22.0	28.0	27	19	148
NC-WEV-14SNPT 1.2	718.2402.504.30	300	1/2	22x1.5	42.5	22.0	34.0	27	19	158
NC-WEV-16SNPT 1.2	718.2402.655.30	200	1/2	24x1.5	46.0	24.5	36.0	30	24	206
NC-WEV-20SNPT 3.4	718.2402.708.30	200	3/4	30x2.0	53.0	26.5	42.0	36	27	318
NC-WEV-25SNPT 1.1	718.2402.810.30	100	1	36x2.0	58.5	30.0	48.0	46	36	616

Baumaße sind Ungefährmaße bei angezogener Überwurfmutter.

Sizes are approximate dimensions at tightened nut.

Las medidas son aproximadas con la tuerca de unión apretada.

D1=Rohr außen-Ø
M1=metrisches Anschlußgewinde

D1=tube outside diameter
M1=metric connecting thread

D1=Ø exterior del tubo
M1=rosca métrica conexión

T-Einschraubverschraubungen

Abdichtung durch Dichtkante Form B nach DIN 3852-2

Male adaptor T fittings

sealing edge form B acc. DIN 3852-2

Racores para roscar T

cierre hermético mediante borde de obturación forma B según DIN 3852-2

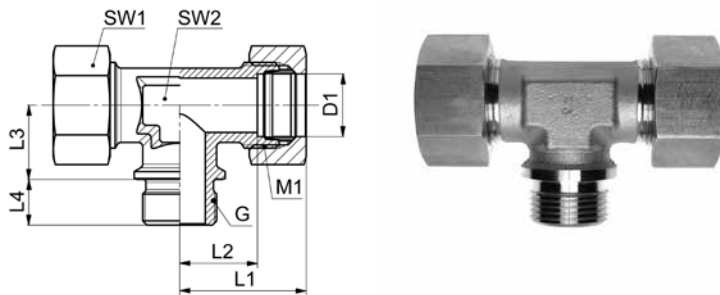

NC-TEV-..LR/SR

Type-D1 G	Mat.-Nr.	PN	G	M1	L1	L2	L3	L4	SW1	SW2	g/Stk
G=Rohrgewinde (zylindrisch)		G=BSP thread (parallel)					G=rosca de conexión (cilíndrica)				
NC-TEV-22LR 3.4	718.3702.768.20	160	3/4	30x2.0	47.5	27.5	26.0	16.0	36	27	381
NC-TEV-20SR 3.4	718.3702.704.30	200	3/4	30x2.0	53.0	26.5	26.0	16.0	36	27	499

Baumaße sind Ungefährmaße bei angezogener Überwurfmutter.

Sizes are approximate dimensions at tightened nut.

Las medidas son aproximadas con la tuerca de unión apretada.

D1=Rohraußen-Ø
M1=metrisches Anschlußgewinde

D1=tube outside diameter
M1=metric connecting thread

D1=Ø exterior del tubo
M1=rosca métrica conexión

T-Einschraubverschraubungen

Abdichtung im Kegengewinde Form C nach DIN 3852-2

Male adaptor T fittings

taper thread sealing form C acc. DIN 3852-2

Racores para roscar T

cierre hermético con rosca cónica forma C según DIN 3852-2

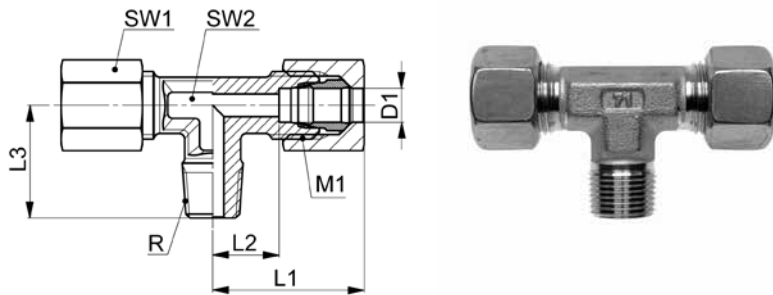

NC-TEV-..LRK/SRK

Type-D1 R	Mat.-Nr.	PN	R	M1	L1	L2	L3	SW1	SW2	g/Stk
R=Rohrgewinde (kegelig)		R=BSP thread (tapered)					R=rosca para tubos (cónica)			
NC-TEV-06LRK 1.8	718.3701.100.20	315	1/8	12x1.5	28.0	12.0	20.0	14	12	52
NC-TEV-06LRK 1.4	718.3701.110.20	315	1/4	12x1.5	28.0	12.0	20.0	14	12	56
NC-TEV-08LRK 1.4	718.3701.170.20	315	1/4	14x1.5	30.0	14.0	26.0	17	12	72
NC-TEV-10LRK 1.4	718.3701.270.20	250	1/4	16x1.5	32.5	15.0	27.0	19	14	76
NC-TEV-10LRK 3.8	718.3701.280.20	250	3/8	16x1.5	32.5	15.0	27.0	19	14	82
NC-TEV-12LRK 3.8	718.3701.390.20	250	3/8	18x1.5	34.0	17.0	28.0	22	17	102
NC-TEV-12LRK 1.2	718.3701.400.20	250	1/2	18x1.5	38.5	21.0	28.0	22	17	138
NC-TEV-15LRK 1.2	718.3701.534.20	250	1/2	22x1.5	39.0	21.0	34.0	27	19	201
NC-TEV-18LRK 1.2	718.3701.646.20	160	1/2	26x1.5	41.0	23.5	36.0	32	24	296
NC-TEV-06SRK 1.4	718.3701.110.30	400	1/4	14x1.5	32.0	16.0	26.0	17	12	100
NC-TEV-08SRK 1.4	718.3701.170.30	400	1/4	16x1.5	33.0	17.0	27.0	19	14	113
NC-TEV-10SRK 3.8	718.3701.280.30	400	3/8	18x1.5	36.5	17.5	28.0	22	17	135
NC-TEV-12SRK 3.8	718.3701.390.30	400	3/8	20x1.5	41.0	21.5	28.0	24	17	159
NC-TEV-14SRK 1.2	718.3701.504.30	300	1/2	22x1.5	43.0	22.0	32.0	27	19	238
NC-TEV-16SRK 1.2	718.3701.566.30	200	1/2	24x1.5	47.0	24.5	32.0	30	24	339

Druckangaben gelten in Verbindung mit zylindrischem Innengewinde.

Pressure information applies in connection with parallel female thread.

Datos de presión válidos en combinación con roscas interiores cilíndricas.

Baumaße sind Ungefährmaße bei angezogener Überwurfmutter.

Sizes are approximate dimensions at tightened nut.

Las medidas son aproximadas con la tuerca de unión apretada.

D1=Rohraußen-Ø
M1=metrisches Anschlußgewinde

D1=tube outside diameter
M1=metric connecting thread

D1=Ø exterior del tubo
M1=rosca métrica conexión

T-Einschraubverschraubungen NPT
Male adaptor T fittings NPT
Racores para roscar T NPT

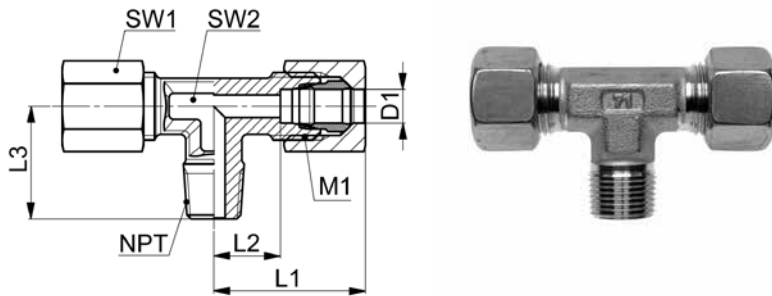

NC-TEV-..LNPT/SNPT

Type-D1 NPT	Mat.-Nr.	PN	NPT	M1	L1	L2	L3	SW1	SW2	g/Stk
NPT=Einschraubgewinde NPT		NPT=tapered male adaptor thread NPT			NPT=rosca de conexión cónica NPT					
NC-TEV-06LNPT 1.8	718.3704.100.20	400	1/8	12x1.5	28.0	12.0	20.0	14	12	50
NC-TEV-10LNPT 1.4	718.3704.270.20	250	1/4	16x1.5	32.5	15.0	27.0	19	14	90
NC-TEV-12LNPT 3.8	718.3704.390.20	250	3/8	18x1.5	34.0	17.0	28.0	22	17	129
NC-TEV-15LNPT 1.2	718.3704.534.20	250	1/2	22x1.5	39.0	21.0	34.0	27	19	215
NC-TEV-18LNPT 1.2	718.3704.646.20	160	1/2	26x1.5	41.0	23.5	36.0	32	24	295
NC-TEV-22LNPT 3.4	718.3704.768.20	160	3/4	30x2.0	47.5	27.5	42.0	36	27	433
NC-TEV-06SNPT 1.4	718.3704.110.30	500	1/4	14x1.5	32.0	16.0	26.0	17	12	94
NC-TEV-12SNPT 3.8	718.3704.390.30	400	3/8	20x1.5	41.0	21.5	28.0	24	17	184
NC-TEV-16SNPT 1.2	718.3704.566.30	200	1/2	24x1.5	47.0	24.5	36.0	30	24	327

Baumaße sind Ungefährmaße bei angezogener Überwurfmutter.

Sizes are approximate dimensions at tightened nut.

Las medidas son aproximadas con la tuerca de unión apretada.

D1=Rohr außen-Ø
M1=metrisches Anschlußgewinde

D1=tube outside diameter
M1=metric connecting thread

D1=Ø exterior del tubo
M1=rosca métrica conexión

L-Einschraubverschraubungen

Abdichtung durch Dichtkante Form B nach DIN 3852-2

Male adaptor L fittings

sealing edge form B acc. DIN 3852-2

Racores para roscar L

cierre hermético mediante borde de obturación forma B según DIN 3852-2

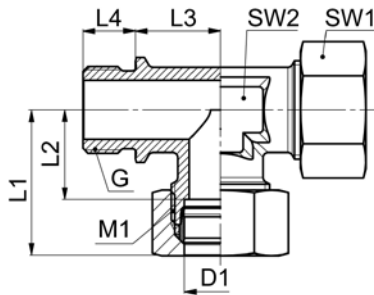

20

NC-LEV-..LR

Type-D1 G	Mat.-Nr.	PN	G	M1	L1	L2	L3	L4	SW1	SW2	g/Stk
G=Rohrgewinde (zylindrisch)		G=BSP thread (parallel)					G=rosca de conexión (cilíndrica)				
NC-LEV-22LR 3.4	718.3712.708.20	160	3/4	30x2.0	47.0	27.5	26.0	16.0	36	27	371

Baumaße sind Ungefährmaße bei angezogener Überwurfmutter.

Sizes are approximate dimensions at tightened nut.

Las medidas son aproximadas con la tuerca de unión apretada.

D1=Rohr außen-Ø
M1=metrisches Anschlußgewinde

D1=tube outside diameter
M1=metric connecting thread

D1=Ø exterior del tubo
M1=rosca métrica conexión

L-Einschraubverschraubungen

Abdichtung im Kegelgewinde Form C nach DIN 3852-2

Male adaptor L fittings

taper thread sealing form C acc. DIN 3852-2

Racores para roscar L

cierre hermético con rosca cónica forma C según DIN 3852-2

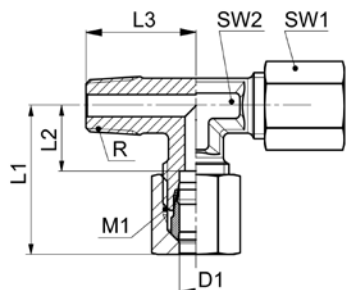

NC-LEV-..LRK/SRK

Type-D1 R	Mat.-Nr.	PN	R	M1	L1	L2	L3	SW1	SW2	g/Stk
R=Rohrgewinde (kegelig)		R=BSP thread (tapered)					R=rosca para tubos (cónica)			
NC-LEV-06LRK 1.8	718.3711.100.20	315	1/8	12x1.5	28.0	12.0	20.0	14	12	53
NC-LEV-08LRK 1.4	718.3711.170.20	315	1/4	14x1.5	30.0	14.0	26.0	17	12	75
NC-LEV-10LRK 1.4	718.3711.270.20	250	1/4	16x1.5	32.0	15.0	27.0	19	14	100
NC-LEV-12LRK 3.8	718.3711.390.20	250	3/8	18x1.5	33.5	17.0	28.0	22	17	120
NC-LEV-15LRK 1.2	718.3711.534.20	250	1/2	22x1.5	38.0	21.0	34.0	27	19	167
NC-LEV-18LRK 1.2	718.3711.646.20	160	1/2	26x1.5	40.5	23.5	36.0	32	24	296
NC-LEV-06SRK 1.4	718.3711.111.30	400	1/4	14x1.5	32.0	16.0	26.0	17	12	97
NC-LEV-08SRK 1.4	718.3711.170.30	400	1/4	16x1.5	33.0	17.0	27.0	19	14	128
NC-LEV-10SRK 3.8	718.3711.280.30	400	3/8	18x1.5	36.0	17.5	28.0	22	17	172
NC-LEV-12SRK 3.8	718.3711.390.30	400	3/8	20x1.5	40.5	21.5	28.0	24	17	244
NC-LEV-14SRK 1.2	718.3711.504.30	300	1/2	22x1.5	43.5	22.0	32.0	27	19	240
NC-LEV-16SRK 1.2	718.3711.566.30	200	1/2	24x1.5	46.0	24.5	32.0	30	24	320

Druckangaben gelten in Verbindung mit zylindrischem Innengewinde.

Pressure information applies in connection with parallel female thread.

Datos de presión válidos en combinación con roscas interiores cilíndricas.

Baumaße sind Ungefährmaße bei angezogener Überwurfmutter.

Sizes are approximate dimensions at tightened nut.

Las medidas son aproximadas con la tuerca de unión apretada.

D1=Rohr außen-Ø
M1=metrisches Anschlußgewinde

D1=tube outside diameter
M1=metric connecting thread

D1=Ø exterior del tubo
M1=rosca métrica conexión

L-Einschraubverschraubungen NPT
Male adaptor L fittings NPT
Racores para roscar L NPT

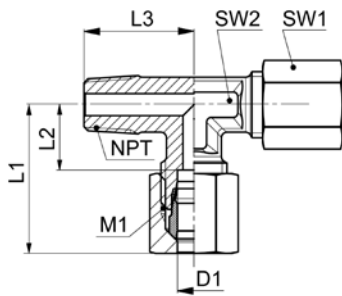

20

NC-LEV-..LNPT/SNPT

Type -D1 NPT	Mat.-Nr.	PN	NPT	M1	L1	L2	L3	SW1	SW2	g/Stk
NPT=Einschraubgewinde NPT		NPT=tapered male adaptor thread NPT				NPT=rosca de conexión cónica NPT				
NC-LEV-08LNPT 1.4	718.3755.170.20	400	1/4	14x1.5	30.0	14.0	26.0	17	12	77
NC-LEV-15LNPT 1.2	718.3755.534.20	250	1/2	22x1.5	38.0	21.0	34.0	27	19	191
NC-LEV-22LNPT 3.4	718.3755.768.20	160	3/4	30x2.0	47.0	27.5	42.0	36	27	347
NC-LEV-06SNPT 1.4	718.3755.110.30	500	1/4	14x1.5	32.0	16.0	26.0	17	12	103
NC-LEV-08SNPT 1.4	718.3755.170.30	500	1/4	16x1.5	33.0	17.0	27.0	19	14	133
NC-LEV-16SNPT 1.2	718.3755.566.30	200	1/2	24x1.5	46.0	24.5	32.0	30	24	320

Baumaße sind Ungefährmaße bei angezogener Überwurfmutter.

Sizes are approximate dimensions at tightened nut.

Las medidas son aproximadas con la tuerca de unión apretada.

D1=Rohr außen-Ø
 M1=metrisches Anschlußgewinde

D1=tube outside diameter
 M1=metric connecting thread

D1=Ø exterior del tubo
 M1=rosca métrica conexión

Einstellbare Winkelverschraubungen 45° mit Dichtkegel und O-Ring
Adjustable elbow fittings 45° with taper and O-ring
Racores angulares ajustables 45° con junta cónica y junta tórica

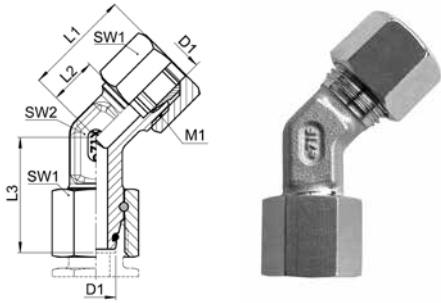

NC-EWKO-..L 45°

Type -D1	Mat.-Nr.	PN	M1	L1	L2	L3	SW1	SW2	g/Stk
NC-EWKO-06L 45°	718.2660.060.20	315	12x1.5	24.5	9.0	26.0	14	12	63
NC-EWKO-08L 45°	718.2660.080.20	315	14x1.5	28.0	12.0	27.5	17	12	63
NC-EWKO-10L 45°	718.2660.100.20	315	16x1.5	29.5	12.0	29.0	19	14	82
NC-EWKO-12L 45°	718.2660.120.20	315	18x1.5	31.0	14.0	29.5	22	17	112
NC-EWKO-15L 45°	718.2660.150.20	315	22x1.5	35.5	17.0	32.5	27	19	181
NC-EWKO-18L 45°	718.2660.180.20	315	26x1.5	34.0	16.5	32.5	32	24	253
NC-EWKO-22L 45°	718.2660.220.20	160	30x2.0	39.5	18.5	38.5	36	27	340

Baumaße sind Ungefährmaße bei angezogener Überwurfmutter.

Sizes are approximate dimensions at tightened nut.

Las medidas son aproximadas con la tuerca de unión apretada.

Dichtungsmaterial: FKM (andere Werkstoffe auf Anfrage)

Sealing material: FKM (other materials on request)

Material de junta tórica: FKM (otros materiales bajo demanda)

Einstellbare Winkelverschraubungen mit Dichtkegel und O-Ring
Adjustable elbow fittings with taper and O-ring
Racores angulares ajustables con junta cónica y junta tórica

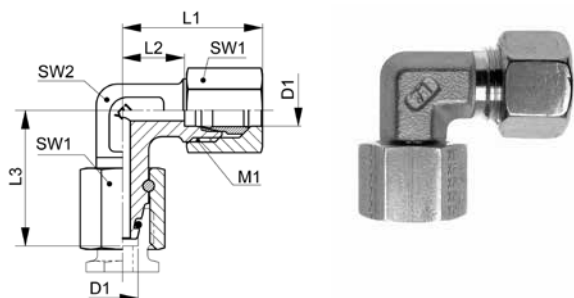

NC-EWKO-..L/S

Type -D1	Mat.-Nr.	PN	M1	L1	L2	L3	SW1	SW2	g/Stk
NC-EWKO-06L	718.2670.060.20	315	12x1.5	28.0	12.0	26.0	14	12	43
NC-EWKO-08L	718.2670.080.20	315	14x1.5	30.0	14.0	27.5	17	12	59
NC-EWKO-10L	718.2670.100.20	250	16x1.5	32.5	15.0	29.0	19	14	80
NC-EWKO-12L	718.2670.120.20	250	18x1.5	33.5	17.0	29.5	22	17	105
NC-EWKO-15L	718.2670.150.20	250	22x1.5	38.0	21.0	32.5	27	19	175
NC-EWKO-18L	718.2670.180.20	160	26x1.5	40.5	23.5	35.5	32	24	248
NC-EWKO-22L	718.2670.220.20	160	30x2.0	47.0	27.5	38.5	36	27	344
NC-EWKO-06S	718.2670.060.30	500	14x1.5	32.0	16.0	27.0	17	12	64
NC-EWKO-08S	718.2670.080.30	500	16x1.5	33.0	17.0	27.5	19	14	86
NC-EWKO-10S	718.2670.100.30	400	18x1.5	36.0	17.5	30.0	22	17	120
NC-EWKO-12S	718.2670.120.30	400	20x1.5	40.5	21.5	31.0	24	17	143
NC-EWKO-14S	718.2670.140.30	300	22x1.5	42.5	22.0	35.0	27	19	188
NC-EWKO-16S	718.2670.160.30	200	24x1.5	46.0	24.5	36.5	30	24	265
NC-EWKO-20S	718.2670.200.30	200	30x2.0	51.5	26.5	44.5	36	27	412
NC-EWKO-25S	718.2670.250.30	100	36x2.0	57.0	30.0	50.0	46	36	763

Baumaße sind Ungefährmaße bei angezogener Überwurfmutter.

Sizes are approximate dimensions at tightened nut.

Las medidas son aproximadas con la tuerca de unión apretada.

Dichtungsmaterial: FKM (andere Werkstoffe auf Anfrage)

Sealing material: FKM (other materials on request)

Material de junta tórica: FKM (otros materiales bajo demanda)

D1=Rohr außen-Ø
M1=metrisches Anschlußgewinde

D1=tube outside diameter
M1=metric connecting thread

D1=Ø exterior del tubo
M1=rosca métrica conexión

Einstellbare Winkel-Einschraubverschraubungen mit Dichtkegel und O-Ring

mit Einschraubstutzen, Abdichtung durch Dichtkante Form B nach DIN 3852-2

Adjustable male adaptor elbow fittings with taper and O-ring

with male adaptor connector, sealing edge form B acc. DIN 3852-2

Racores para roscar en codo ajustables con junta cónica y junta tórica

con racor para roscar, cierre hermético mediante borde de obturación forma B según DIN 3852-2

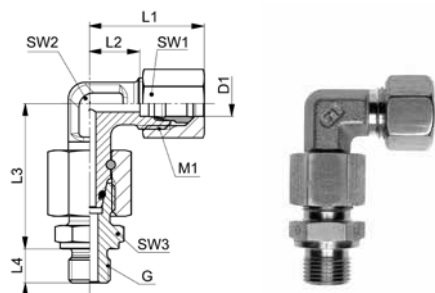

NC-EWKO-..LR/SR

Type-D1 G	Mat.-Nr.	PN	G	M1	L1	L2	L3	L4	SW1	SW2	SW3	g/Stk
G=Rohrgewinde (zylindrisch)		G=BSP thread (parallel)				G=rosca de conexión (cilíndrica)						
NC-EWKO-06LR 1.8	718.2671.100.20	315	1/8	12x1.5	28.0	12.0	34.5	8.0	14	12	14	57
NC-EWKO-08LR 1.4	718.2671.170.20	315	1/4	14x1.5	30.0	14.0	37.0	12.0	17	12	19	87
NC-EWKO-10LR 1.4	718.2671.270.20	250	1/4	16x1.5	32.5	15.0	39.5	12.0	19	14	19	109
NC-EWKO-12LR 1.4	718.2671.380.20	250	1/4	18x1.5	33.5	17.0	41.5	12.0	22	17	19	137
NC-EWKO-12LR 3.8	718.2671.390.20	250	3/8	18x1.5	33.5	17.0	42.0	12.0	22	17	22	147
NC-EWKO-12LR 1.2	718.2671.400.20	250	1/2	18x1.5	33.5	17.0	42.5	14.0	22	17	27	175
NC-EWKO-15LR 1.2	718.2671.534.20	250	1/2	22x1.5	38.0	21.0	46.5	14.0	27	19	27	248
NC-EWKO-18LR 1.2	718.2671.646.20	160	1/2	26x1.5	40.5	23.5	50.0	14.0	32	24	27	320
NC-EWKO-22LR 3.4	718.2671.768.20	160	3/4	30x2.0	47.0	27.5	55.0	16.0	36	27	32	450
NC-EWKO-06SR 1.4	718.2671.110.30	500	1/4	14x1.5	32.0	16.0	40.0	12.0	17	12	19	98
NC-EWKO-08SR 1.4	718.2671.170.30	500	1/4	16x1.5	33.0	17.0	42.0	12.0	19	14	19	128
NC-EWKO-10SR 3.8	718.2671.280.30	400	3/8	18x1.5	36.0	17.5	45.0	12.0	22	17	22	178
NC-EWKO-12SR 3.8	718.2671.390.30	400	3/8	20x1.5	40.5	21.5	48.0	12.0	24	17	22	207
NC-EWKO-12SR 1.2	718.2671.400.30	400	1/2	20x1.5	40.5	21.5	48.5	14.0	24	17	27	242
NC-EWKO-14SR 1.2	718.2671.504.30	300	1/2	22x1.5	42.5	22.0	54.0	14.0	27	19	27	287
NC-EWKO-16SR 1.2	718.2671.566.30	200	1/2	24x1.5	46.0	24.5	55.0	14.0	30	24	27	359
NC-EWKO-20SR 3.4	718.2671.704.30	200	3/4	30x2.0	51.5	26.5	65.0	14.0	36	27	32	567
NC-EWKO-25SR 1.1	718.2671.810.30	100	1	36x2.0	57.0	30.0	73.0	18.0	46	36	41	1036

Baumaße sind Ungefährmaße bei angezogener Überwurfmutter.

Sizes are approximate dimensions at tightened nut.

Las medidas son aproximadas con la tuerca de unión apretada.

Dichtungsmaterial: FKM (andere Werkstoffe auf Anfrage)

Sealing material: FKM (other materials on request)

Material de junta tórica: FKM (otros materiales bajo demanda)

Einstellbare Winkel-Einschraubverschraubungen mit Dichtkegel und O-Ring

mit Einschraubstutzen, Abdichtung durch Profildichtring Form E nach ISO 1179-2

Adjustable male adaptor elbow fittings with taper and O-ring

with male adaptor connector, profile sealing ring form E acc. ISO 1179-2

Racores para roscar en codo ajustables con junta cónica y junta tórica

con racor para roscar, cierre hermético mediante junta con perfil forma E según ISO 1179-2

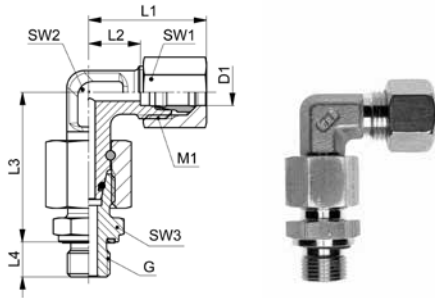

20

NC-EWKO-..LR WD/SR WD

Type-D1 G	Mat.-Nr.	PN	G	M1	L1	L2	L3	L4	SW1	SW2	SW3	g/Stk
G=Rohrgewinde (zylindrisch)		G=BSP thread (parallel)			G=rosca de conexión (cilíndrica)							
NC-EWKO-06LR 1.8 WD	718.2672.100.20	315	1/8	12x1.5	28.0	12.0	34.0	8.0	14	12	14	57
NC-EWKO-08LR 1.4 WD	718.2672.170.20	315	1/4	14x1.5	30.0	14.0	37.0	12.0	17	12	19	86
NC-EWKO-10LR 1.4 WD	718.2672.270.20	250	1/4	16x1.5	32.5	15.0	40.0	12.0	19	14	19	108
NC-EWKO-12LR 1.4 WD	718.2672.380.20	250	1/4	18x1.5	33.5	17.0	41.5	12.0	22	17	19	134
NC-EWKO-12LR 3.8 WD	718.2672.390.20	250	3/8	18x1.5	33.5	17.0	42.0	12.0	22	17	22	147
NC-EWKO-12LR 1.2 WD	718.2672.400.20	250	1/2	18x1.5	33.5	17.0	42.5	14.0	22	17	27	175
NC-EWKO-15LR 1.2 WD	718.2672.534.20	250	1/2	22x1.5	38.0	21.0	43.5	14.0	27	19	27	248
NC-EWKO-18LR 1.2 WD	718.2672.646.20	160	1/2	26x1.5	40.5	23.5	50.0	14.0	32	24	27	320
NC-EWKO-22LR 3.4 WD	718.2672.768.20	160	3/4	30x2.0	47.0	27.5	55.0	16.0	36	27	32	448
NC-EWKO-06SR 1.4 WD	718.2672.110.30	500	1/4	14x1.5	32.0	16.0	39.0	12.0	17	12	19	100
NC-EWKO-08SR 1.4 WD	718.2672.170.30	500	1/4	16x1.5	33.0	17.0	41.5	12.0	19	14	19	127
NC-EWKO-10SR 3.8 WD	718.2672.280.30	400	3/8	18x1.5	36.0	17.5	45.0	12.0	22	17	22	176
NC-EWKO-12SR 3.8 WD	718.2672.390.30	400	3/8	20x1.5	40.5	21.5	48.0	12.0	24	17	22	207
NC-EWKO-12SR 1.2 WD	718.2672.400.30	400	1/2	20x1.5	40.5	21.5	48.5	14.0	24	17	27	241
NC-EWKO-14SR 1.2 WD	718.2672.504.30	300	1/2	22x1.5	42.5	22.0	54.0	14.0	27	19	27	287
NC-EWKO-16SR 1.2 WD	718.2672.566.30	200	1/2	24x1.5	46.0	24.5	55.0	14.0	30	24	27	359
NC-EWKO-20SR 3.4 WD	718.2672.704.30	200	3/4	30x2.0	51.5	26.5	65.0	18.0	36	27	32	564
NC-EWKO-25SR 1.1 WD	718.2672.810.30	100	1	36x2.0	57.0	30.0	72.5	18.0	46	36	41	1033

Baumaße sind Ungefährmaße bei angezogener Überwurfmutter.

Sizes are approximate dimensions at tightened nut.

Las medidas son aproximadas con la tuerca de unión apretada.

Dichtungsmaterial: FKM (andere Werkstoffe auf Anfrage)

Sealing material: FKM (other materials on request)

Material de junta tórica: FKM (otros materiales bajo demanda)

D1=Rohraußen-Ø
M1=metrisches Anschlußgewinde

D1=tube outside diameter
M1=metric connecting thread

D1=Ø exterior del tubo
M1=rosca métrica conexión

Einstellbare Winkel-Einschraubverschraubungen

mit Kontermutter, Abdichtung durch gekammerten O-Ring, ISO 1179-3

Adjustable male adaptor elbow fittings

with counter nut, sealing with restraining O-ring, ISO 1179-3

Racores para roscar en codo ajustables

con contratueras, cierre hermético mediante junta tórica protegida, ISO 1179-3

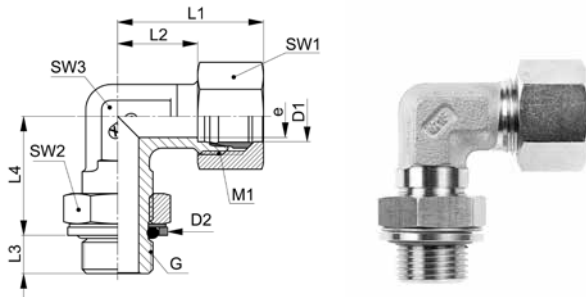

NC-WEE-..LR

Type-D1 G	Mat.-Nr.	PN	G	M1	D2	L1	L2	L3	L4	SW1	SW2	SW3	g/Stk
G=Rohrgewinde (zylindrisch)		G=BSP thread (parallel)							G=rosca de conexión (cilíndrica)				
NC-WEE-06LR 1.8	718.2407.100.20	200	1/8	12x1.5	15.0	28.0	12.0	7.0	19.0	14	14	12	40
NC-WEE-08LR 1.4	718.2407.170.20	200	1/4	14x1.5	19.5	30.0	12.0	9.0	23.0	17	19	12	63
NC-WEE-10LR 1.4	718.2407.270.20	200	1/4	16x1.5	19.5	32.0	12.0	9.0	25.0	19	19	14	77
NC-WEE-12LR 3.8	718.2407.390.20	200	3/8	18x1.5	23.5	33.5	17.0	9.0	28.0	22	22	17	106
NC-WEE-15LR 1.2	718.2407.534.20	200	1/2	22x1.5	28.5	38.0	21.0	13.0	30.0	27	27	19	179
NC-WEE-18LR 1.2	718.2407.646.20	160	1/2	26x1.5	28.5	40.5	24.0	13.0	36.0	32	27	24	246
NC-WEE-22LR 3.4	718.2407.768.20	160	3/4	30x2.0	34.5	47.0	28.0	13.0	36.0	36	36	27	356

Baumaße sind Ungefährmaße bei angezogener Überwurfmutter.

Sizes are approximate dimensions at tightened nut.

Las medidas son aproximadas con la tuerca de unión apretada.

Dichtungsmaterial: FKM (andere Werkstoffe auf Anfrage)

Sealing material: FKM (other materials on request)

Material de junta tórica: FKM (otros materiales bajo demanda).

Konterscheibe aus Edelstahl 1.4301 / AISI 304

Counter nut made of stainless steel 1.4301 / AISI 304

Contratuerca hecho de acero inoxidable 1.4301 / AISI 304

Montageanleitung

Installation instruction

Instrucción de montaje

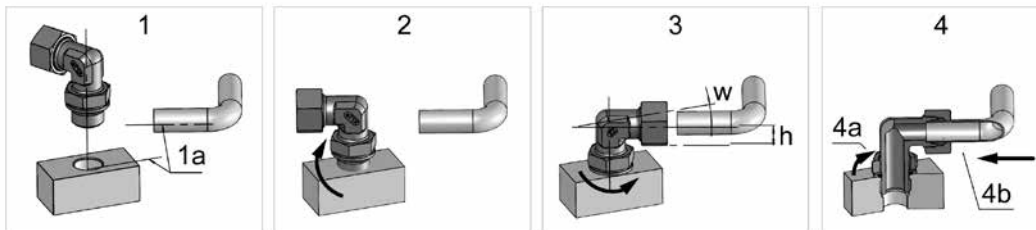

- 1 - Ausgangslage
1a: abweichende Winkel
- 2 - Verschraubung bis zum Anschlag einschrauben
- 3 - Verschraubung ausrichten
Höhe (h) +/- Gewindesteigung
Winkel (w)
- 4 - Fertigmontage
4a: Kontermutter anziehen
4b: Rohr montieren

- 1 - Starting position
1a: different angles
- 2 - Screw fitting until it stops
- 3 - Align fitting
height (h) +/- thread pitch angle (w)
- 4 - Final assembly
4a: Tighten counter nut
4b: Install tube

- 1 - Situación inicial
1a: ángulos diferentes
- 2 - Enroscar el racor hasta que se detenga
- 3 - Alinear el racor
altura (h) +/- paso de rosca
ángulo (w)
- 4 - Montaje final
4a: Apriete contratuerca
4b: Instalar tubo

D1=Rohr außen-Ø
M1=metrisches Anschlußgewinde

D1=tube outside diameter
M1=metric connecting thread

D1=Ø exterior del tubo
M1=rosca métrica conexión

Einstellbare Winkel-Einschraubverschraubungen

mit Kontermutter, Abdichtung durch gekammerten O-Ring, ISO 1179-3

Adjustable male adaptor elbow fittings

with counter nut, sealing with restraining O-ring, ISO 1179-3

Racores para roscar en codo ajustables

con contratueras, cierre hermético mediante junta tórica protegida, ISO 1179-3

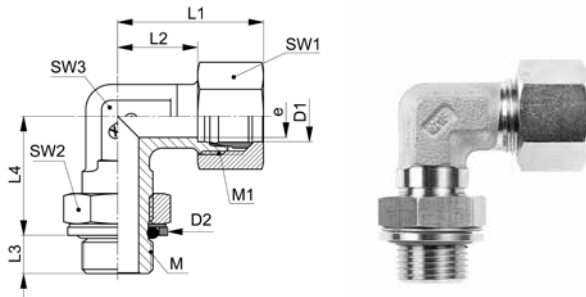

20

NC-WEE-..LM

Type-D1 M	Mat.-Nr.	PN	M	M1	D2	L1	L2	L3	L4	SW1	SW2	SW3	g/Stk
M=metrisches Gewinde (zylindrisch)		M=metric thread (parallel)							M=rosca métrica (cilíndrica)				
NC-WEE-10LM 14x1,5	718.2408.280.20	200	14x1.5	16x1.5	19.5	32.5	15.0	10.0	24.0	19	19	14	79
NC-WEE-18LM 22x1,5	718.2408.460.20	200	22x1.5	26x1.5	28.5	41.0	24.0	12.0	33.0	32	27	24	236

Baumaße sind Ungefährmaße bei angezogener Überwurfmutter.

Sizes are approximate dimensions at tightened nut.

Las medidas son aproximadas con la tuerca de unión apretada.

Dichtungsmaterial: FKM (andere Werkstoffe auf Anfrage)

Sealing material: FKM (other materials on request)

Material de junta tórica: FKM (otros materiales bajo demanda).

Konterscheibe aus Edelstahl 1.4301 / AISI 304

Counter nut made of stainless steel 1.4301 / AISI 304

Contratuerca hecho de acero inoxidable 1.4301 / AISI 304

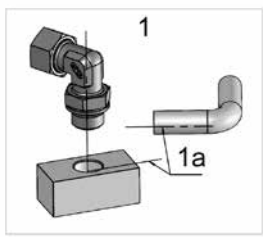
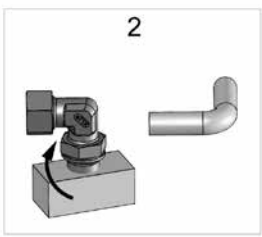
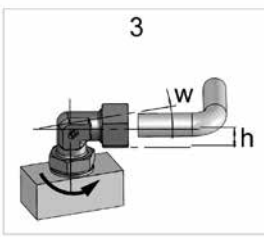
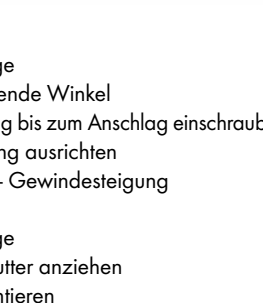
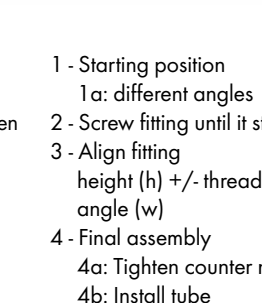
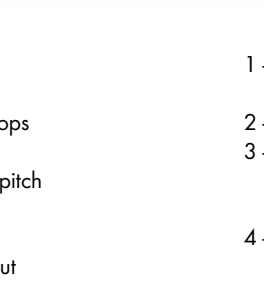
Montageanleitung	Installation instruction	Instrucción de montaje
 <p>1 - Ausgangslage 1a: abweichende Winkel</p>	 <p>2 - Screw fitting until it stops</p>	 <p>3 - Alinear el racor altura (h) +/- paso de rosca ángulo (w)</p>
 <p>4 - Fertigmontage 4a: Kontermutter anziehen 4b: Rohr montieren</p>	 <p>4 - Final assembly 4a: Tighten counter nut 4b: Install tube</p>	 <p>4 - Montaje final 4a: Apriete contratuerca 4b: Instalar tubo</p>

D1=Rohr außen-Ø
M1=metrisches Anschlußgewinde

D1=tube outside diameter
M1=metric connecting thread

D1=Ø exterior del tubo
M1=rosca métrica conexión

Einstellbare T-Verschraubungen mit Dichtkegel und O-Ring
Adjustable T fittings with taper and O-ring
Racores T ajustables con junta cónica y junta tórica

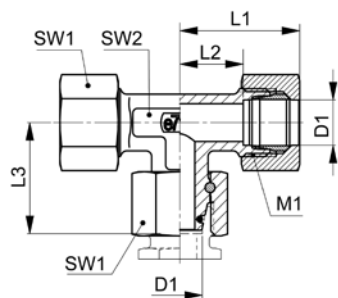

NC-ETKO-..L/S

Type -D1	Mat.-Nr.	PN	M1	L1	L2	L3	SW1	SW2	SW3	g/Stk
NC-ETKO-06L	718.3670.060.20	315	12x1.5	28.0	12.0	26.0	14	12	14	54
NC-ETKO-08L	718.3670.080.20	315	14x1.5	30.0	14.0	27.5	17	12	17	76
NC-ETKO-10L	718.3670.100.20	250	16x1.5	32.5	15.0	29.0	19	14	19	107
NC-ETKO-12L	718.3670.120.20	250	18x1.5	34.0	17.0	29.5	22	17	22	135
NC-ETKO-15L	718.3670.150.20	250	22x1.5	39.0	21.0	32.5	27	19	22	223
NC-ETKO-18L	718.3670.180.20	160	26x1.5	41.0	23.5	35.5	32	24	32	332
NC-ETKO-22L	718.3670.220.20	160	30x2.0	47.5	27.5	38.5	36	27	36	439
NC-ETKO-06S	718.3670.060.30	500	14x1.5	32.0	16.0	27.0	17	12	17	87
NC-ETKO-08S	718.3670.080.30	500	16x1.5	33.0	17.0	27.5	19	14	19	109
NC-ETKO-10S	718.3670.100.30	400	18x1.5	36.5	17.5	30.0	22	17	22	169
NC-ETKO-12S	718.3670.120.30	400	20x1.5	41.0	21.5	31.0	24	17	24	212
NC-ETKO-14S	718.3670.140.30	300	22x1.5	43.0	22.0	35.0	27	19	27	281
NC-ETKO-16S	718.3670.160.30	200	24x1.5	47.0	24.5	36.5	30	24	30	382
NC-ETKO-20S	718.3670.200.30	200	30x2.0	53.0	26.5	44.5	36	27	36	542
NC-ETKO-25S	718.3670.250.30	100	36x2.0	58.0	30.0	50.0	46	36	46	1050

Baumaße sind Ungefährmaße bei angezogener Überwurfmutter.

Sizes are approximate dimensions at tightened nut.

Las medidas son aproximadas con la tuerca de unión apretada.

Dichtungsmaterial: FKM (andere Werkstoffe auf Anfrage)

Sealing material: FKM (other materials on request)

Material de junta tórica: FKM (otros materiales bajo demanda)

Einstellbare L-Verschraubungen mit Dichtkegel und O-Ring
Adjustable L fittings with taper and O-ring
Racores L ajustables con junta cónica y junta tórica

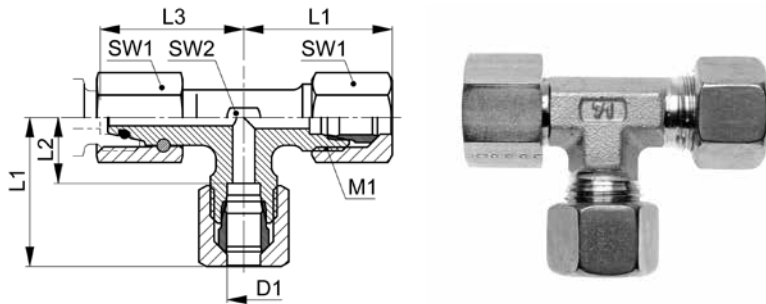

20

NC-ELKO-..L/S

Type -D1	Mat.-Nr.	PN	M1	L1	L2	L3	SW1	SW2	SW3	g/Stk
NC-ELKO-06L	718.3671.060.20	315	12x1.5	28.0	12.0	26.0	14	12	14	53
NC-ELKO-08L	718.3671.080.20	315	14x1.5	30.0	14.0	27.5	17	12	17	80
NC-ELKO-10L	718.3671.100.20	250	16x1.5	32.0	15.0	29.0	19	14	19	109
NC-ELKO-12L	718.3671.120.20	250	18x1.5	33.5	17.0	29.5	22	17	22	132
NC-ELKO-15L	718.3671.150.20	250	22x1.5	38.0	21.0	32.5	27	19	27	223
NC-ELKO-18L	718.3671.180.20	160	26x1.5	40.5	23.5	35.5	32	24	32	337
NC-ELKO-22L	718.3671.220.20	160	30x2.0	47.0	27.5	38.5	36	27	36	439
NC-ELKO-06S	718.3671.060.30	500	14x1.5	32.0	16.0	25.5	17	12	17	89
NC-ELKO-08S	718.3671.080.30	500	16x1.5	33.0	17.0	25.5	19	14	19	109
NC-ELKO-10S	718.3671.100.30	400	18x1.5	36.0	17.5	28.0	22	17	22	170
NC-ELKO-12S	718.3671.120.30	400	20x1.5	40.5	21.5	29.5	24	17	24	212
NC-ELKO-14S	718.3671.140.30	300	22x1.5	42.5	22.0	33.0	27	19	27	277
NC-ELKO-16S	718.3671.160.30	200	24x1.5	46.0	24.5	33.0	30	24	30	345
NC-ELKO-20S	718.3671.200.30	200	30x2.0	51.5	26.5	41.5	36	27	36	548
NC-ELKO-25S	718.3671.250.30	100	36x2.0	57.0	30.0	45.5	46	36	46	1036

Baumaße sind Ungefährmaße bei angezogener Überwurfmutter.

Sizes are approximate dimensions at tightened nut.

Las medidas son aproximadas con la tuerca de unión apretada.

Dichtungsmaterial: FKM (andere Werkstoffe auf Anfrage)

Sealing material: FKM (other materials on request)

Material de junta tórica: FKM (otros materiales bajo demanda)

D1=Rohr außen-Ø
M1=metrisches Anschlußgewinde

D1=tube outside diameter
M1=metric connecting thread

D1=Ø exterior del tubo
M1=rosca métrica conexión

Winkel-Schwenkverschraubungen

Abdichtung mit metallischem Dichtkantenring

Banjo elbow fittings

sealing with metal seal-edge ring

Racores orientables angulares

junta con anillo con borde de obturación metálico

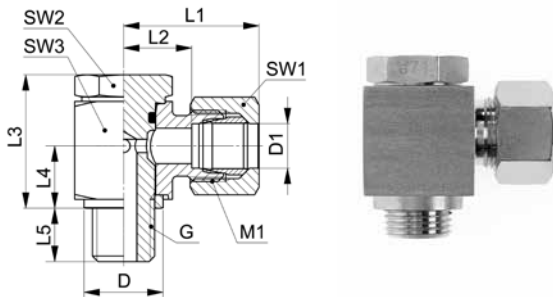

NC-ESWV-..LR/SR

Type-D1 G	Mat.-Nr.	PN	G	M1	D	L1	L2	L3	L4	L5	SW1	SW2	SW3	g/Stk
G=Rohrgewinde (zylindrisch)		G=BSP thread (parallel)			G=rosca de conexión (cilíndrica)									
NC-ESWV-06LR 1.8	718.2850.100.20	400	1/8	12x1.5	14.0	28.0	12.0	21.0	10.5	8.0	14	14	17	59
NC-ESWV-06LR 1.4	718.2850.110.20	400	1/4	12x1.5	18.0	28.0	12.0	30.0	14.0	12.0	14	19	19	59
NC-ESWV-08LR 1.4	718.2850.170.20	400	1/4	14x1.5	18.0	30.5	14.5	30.0	14.0	12.0	17	19	22	93
NC-ESWV-10LR 1.4	718.2850.270.20	250	1/4	16x1.5	18.0	32.5	15.5	30.0	14.0	12.0	19	19	22	102
NC-ESWV-12LR 1.4	718.2850.380.20	250	1/4	18x1.5	18.0	34.5	18.0	30.0	14.0	12.0	22	19	22	158
NC-ESWV-12LR 3.8	718.2850.390.20	250	3/8	18x1.5	21.0	34.5	18.0	34.5	16.5	12.0	22	22	27	159
NC-ESWV-15LR 1.2	718.2850.534.20	250	1/2	22x1.5	27.0	38.5	21.5	44.0	21.5	14.0	27	27	32	284
NC-ESWV-18LR 1.2	718.2850.646.20	160	1/2	26x1.5	27.0	38.0	21.5	44.0	21.5	14.0	32	27	32	320
NC-ESWV-22LR 3.4	718.2850.768.20	160	3/4	30x2.0	32.0	47.0	27.5	49.0	24.0	16.0	36	32	41	485
NC-ESWV-06SR 1.4	718.2850.110.30	500	1/4	14x1.5	18.0	32.5	16.5	30.0	14.0	12.0	17	19	22	87
NC-ESWV-08SR 1.4	718.2850.170.30	500	1/4	16x1.5	18.0	32.5	16.5	30.0	14.0	12.0	19	19	22	103
NC-ESWV-10SR 3.8	718.2850.280.30	400	3/8	18x1.5	21.0	37.0	18.5	34.5	16.5	12.0	22	22	27	170
NC-ESWV-12SR 3.8	718.2850.390.30	400	3/8	20x1.5	21.0	37.5	18.5	34.5	16.5	12.0	24	22	27	179
NC-ESWV-14SR 1.2	718.2850.504.30	300	1/2	22x1.5	27.0	43.0	22.5	44.0	21.5	14.0	27	27	32	303
NC-ESWV-16SR 1.2	718.2850.566.30	200	1/2	24x1.5	27.0	43.5	22.0	44.0	21.5	14.0	30	27	32	316
NC-ESWV-20SR 3.4	718.2850.704.30	200	3/4	30x2.0	32.0	51.5	26.5	49.0	24.0	16.0	36	32	41	518
NC-ESWV-25SR 1.1	718.2850.810.30	100	1	36x2.0	39.0	58.5	31.5	60.0	30.5	16.0	46	41	46	1030

Baumaße sind Ungefährmaße bei angezogener Überwurfmutter.

Sizes are approximate dimensions at tightened nut.

Las medidas son aproximadas con la tuerca de unión apretada.

Dichtungsmaterial: FKM (andere Werkstoffe auf Anfrage)

Sealing material: FKM (other materials on request)

Material de junta tórica: FKM (otros materiales bajo demanda)

G	1/8	1/4	3/8	1/2	3/4	1
[Nm]	15	40	70	110	160	210

Anzugsdrehmoment für Hohlverschraubung in Nm

Tightening torque for hollow bolt in Nm

Pares de apriete para tornillo hueco en Nm

D1=Rohr außen-Ø
M1=metrisches Anschlußgewinde

D1=tube outside diameter
M1=metric connecting thread

D1=Ø exterior del tubo
M1=rosca métrica conexión

Winkel-Schwenkverschraubungen

Abdichtung mit gekammertem FKM Weichdichtring

Banjo elbow fittings

sealing with restraining seal ring FKM

Racores orientables angulares

junta con anillo retentivo FKM blanda

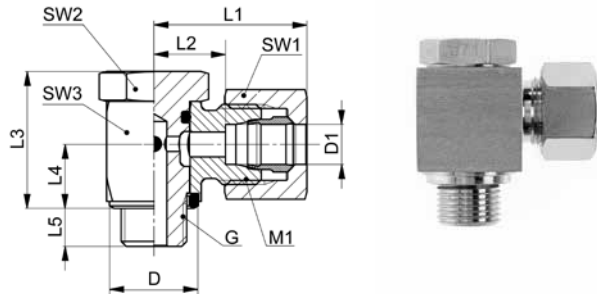

NC-ESWV-..LR WD/SR WD

Type-D1 G	Mat.-Nr.	PN	G	M1	D	L1	L2	L3	L4	L5	SW1	SW2	SW3	g/Stk
G=Rohrgewinde (zylindrisch)		G=BSP thread (parallel)			G=rosca de conexión (cilíndrica)									
NC-ESWV-06LR 1.8 WD	718.2851.100.20	400	1/8	12x1.5	15.0	28.0	12.0	21.0	10.5	8.0	14	14	17	59
NC-ESWV-06LR 1.4 WD	718.2851.110.20	400	1/4	12x1.5	19.0	28.0	12.0	30.0	14.0	12.0	14	19	19	59
NC-ESWV-08LR 1.4 WD	718.2851.170.20	400	1/4	14x1.5	19.0	30.5	14.5	30.0	14.0	12.0	17	19	22	93
NC-ESWV-10LR 1.4 WD	718.2851.270.20	250	1/4	16x1.5	19.0	32.5	15.5	30.0	14.0	12.0	19	19	22	102
NC-ESWV-12LR 1.4 WD	718.2851.380.20	250	1/4	18x1.5	19.0	34.5	18.0	30.0	14.0	12.0	22	19	22	158
NC-ESWV-12LR 3.8 WD	718.2851.390.20	250	3/8	18x1.5	22.0	34.5	18.0	34.5	16.5	12.0	22	22	27	159
NC-ESWV-15LR 1.2 WD	718.2851.534.20	250	1/2	22x1.5	27.0	38.5	21.5	44.0	21.5	14.0	27	27	32	284
NC-ESWV-18LR 1.2 WD	718.2851.646.20	160	1/2	26x1.5	27.0	38.0	21.5	44.0	21.5	14.0	32	27	32	320
NC-ESWV-22LR 3.4 WD	718.2851.768.20	160	3/4	30x2.0	33.0	47.0	27.5	49.0	24.0	16.0	36	32	41	485
NC-ESWV-06SR 1.4 WD	718.2851.110.30	500	1/4	14x1.5	19.0	32.5	16.5	30.0	14.0	12.0	17	19	22	87
NC-ESWV-08SR 1.4 WD	718.2851.170.30	500	1/4	16x1.5	19.0	32.5	16.5	30.0	14.0	12.0	19	19	22	103
NC-ESWV-10SR 3.8 WD	718.2851.280.30	400	3/8	18x1.5	22.0	37.0	18.5	34.5	16.5	12.0	22	22	27	170
NC-ESWV-12SR 3.8 WD	718.2851.390.30	400	3/8	20x1.5	22.0	37.5	18.5	34.5	16.5	12.0	24	22	27	179
NC-ESWV-14SR 1.2 WD	718.2851.504.30	300	1/2	22x1.5	27.0	43.0	22.5	44.0	21.5	14.0	27	27	32	303
NC-ESWV-16SR 1.2 WD	718.2851.566.30	200	1/2	24x1.5	27.0	43.5	22.0	44.0	21.5	14.0	30	27	32	316
NC-ESWV-20SR 3.4 WD	718.2851.704.30	200	3/4	30x2.0	33.0	51.5	26.5	49.0	24.0	16.0	36	32	41	518
NC-ESWV-25SR 1.1 WD	718.2851.810.30	100	1	36x2.0	40.0	58.5	31.5	49.0	30.5	18.0	46	41	46	1030

Baumaße sind Ungefährmaße bei angezogener Überwurfmutter.

Sizes are approximate dimensions at tightened nut.

Las medidas son aproximadas con la tuerca de unión apretada.

Dichtungsmaterial: FKM (andere Werkstoffe auf Anfrage)

Sealing material: FKM (other materials on request)

Material de junta tórica: FKM (otros materiales bajo demanda)

G	1/8	1/4	3/8	1/2	3/4	1
[Nm]	15	40	70	110	160	210

Anzugsdrehmoment für HohlSchraube in Nm

Tightening torque for hollow bolt in Nm

Pares de apriete para tornillo hueco en Nm

D1=Rohr außen-Ø
M1=metrisches Anschlußgewinde

D1=tube outside diameter
M1=metric connecting thread

D1=Ø exterior del tubo
M1=rosca métrica conexión

Winkel-Schwenkverschraubungen

Abdichtung mit metallischem Dichtkantenring

Banjo elbow fittings

sealing with metal seal-edge ring

Racores orientables angulares

junta con anillo con borde de obturación metálico

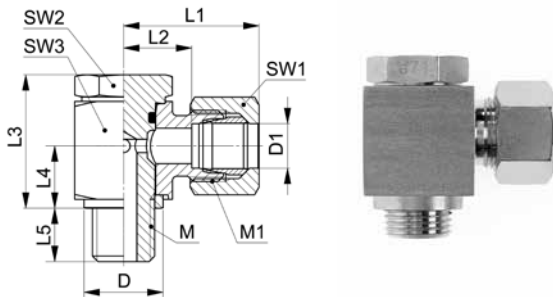

NC-ESWV-..LM/SM

Type-D1 M	Mat.-Nr.	PN	M	M1	D	L1	L2	L3	L4	L5	SW1	SW2	SW3	g/Stk
M=metrisches Gewinde (zylindrisch)	M=metric thread (parallel)	M=rosca métrica (cilíndrica)												
NC-ESWV-06LM 10x1,0	718.2853.180.20	400	10x1.0	12x1.5	14.0	28.0	12.0	21.0	10.5	8.0	14	14	17	59
NC-ESWV-08LM 12x1,5	718.2853.240.20	400	12x1.5	14x1.5	18.0	30.5	14.5	30.0	14.0	12.0	17	19	22	90
NC-ESWV-10LM 14x1,5	718.2853.280.20	250	14x1.5	16x1.5	18.0	32.5	15.5	30.0	14.0	12.0	19	19	22	103
NC-ESWV-12LM 16x1,5	718.2853.330.20	250	16x1.5	18x1.5	21.0	34.5	18.0	34.5	16.5	12.0	22	22	27	158
NC-ESWV-15LM 18x1,5	718.2853.390.20	250	18x1.5	22x1.5	23.0	38.5	21.5	38.5	18.5	12.0	27	24	27	209
NC-ESWV-18LM 22x1,5	718.2853.460.20	160	22x1.5	30x2.0	27.0	38.0	21.0	44.0	21.5	14.0	32	27	32	320
NC-ESWV-22LM 26x1,5	718.2853.535.20	160	26x1.5	30x2.0	32.0	47.0	27.5	49.0	24.0	16.0	36	32	41	485
NC-ESWV-06SM 12x1,5	718.2853.195.30	500	12x1.5	14x1.5	18.0	32.5	16.5	30.0	14.0	12.0	17	19	22	85
NC-ESWV-08SM 14x1,5	718.2853.245.30	500	14x1.5	16x1.5	18.0	32.5	16.5	30.0	14.0	12.0	19	19	22	103
NC-ESWV-10SM 16x1,5	718.2853.285.30	400	16x1.5	18x1.5	21.0	37.0	18.5	34.5	16.5	12.0	22	22	27	170
NC-ESWV-12SM 18x1,5	718.2853.333.30	400	18x1.5	20x1.5	23.0	39.0	20.0	38.5	18.5	12.0	24	24	27	220
NC-ESWV-14SM 20x1,5	718.2853.382.30	300	20x1.5	22x1.5	27.0	43.0	22.5	44.0	21.5	14.0	27	27	32	280
NC-ESWV-16SM 22x1,5	718.2853.410.30	200	22x1.5	24x1.5	27.0	43.5	22.0	44.0	21.5	14.0	30	27	32	320
NC-ESWV-20SM 27x2,0	718.2853.506.30	200	27x2.0	30x2.0	32.0	51.5	26.5	49.0	24.0	16.0	36	32	41	518
NC-ESWV-25SM 33x2,0	718.2853.550.30	100	33x2.0	36x2.0	39.0	58.5	31.5	60.0	30.5	18.0	46	41	46	1030

Baumaße sind Ungefährmaße bei angezogener Überwurfmutter.

Sizes are approximate dimensions at tightened nut.

Las medidas son aproximadas con la tuerca de unión apretada.

Dichtungsmaterial: FKM (andere Werkstoffe auf Anfrage)

Sealing material: FKM (other materials on request)

Material de junta tórica: FKM (otros materiales bajo demanda)

M	10x1.0	12/14x1.5	16x1.5	18x1.5	20x1.5	22x1.5	26x1.5	27x2.0	33x2.0
[Nm]	15	25	45	60	110	80	150	160	210

Anzugsdrehmoment für HohlSchraube in Nm

Tightening torque for hollow bolt in Nm

Pares de apriete para tornillo hueco en Nm

Winkel-Schwenkverschraubungen

Abdichtung mit gekammertem FKM Weichdichtring

Banjo elbow fittings

sealing with restraining seal ring FKM

Racores orientables angulares

junta con anillo retentivo FKM blanda

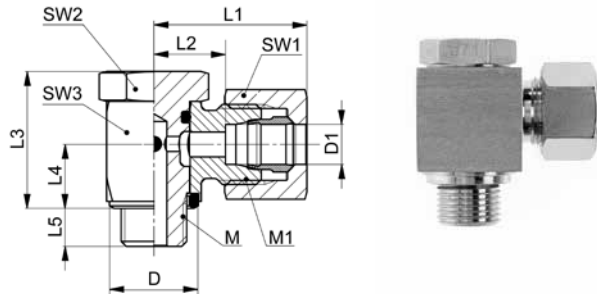

NC-ESWV-..LM WD/SM WD

Type-D1 M	Mat.-Nr.	PN	M	M1	D	L1	L2	L3	L4	L5	SW1	SW2	SW3	g/Stk
M=metrisches Gewinde (zylindrisch)	M=metric thread (parallel)	M=rosca métrica (cilíndrica)												
NC-ESWV-06LM 10x1,0 WD	718.2852.180.20	400	10x1.0	12x1.5	15.0	28.0	12.0	21.0	10.5	8.0	14	14	17	59
NC-ESWV-08LM 12x1,5 WD	718.2852.240.20	400	12x1.5	14x1.5	19.0	30.5	14.5	30.0	14.0	12.0	17	19	22	90
NC-ESWV-10LM 14x1,5 WD	718.2852.280.20	250	14x1.5	16x1.5	19.0	32.5	5.0	30.0	14.0	12.0	19	19	22	103
NC-ESWV-12LM 16x1,5 WD	718.2852.330.20	250	16x1.5	18x1.5	22.0	34.5	18.0	34.5	16.5	12.0	22	22	27	158
NC-ESWV-15LM 18x1,5 WD	718.2852.390.20	250	18x1.5	22x1.5	24.0	38.5	21.5	38.5	18.5	12.0	27	24	27	209
NC-ESWV-18LM 22x1,5 WD	718.2852.460.20	160	22x1.5	26x1.5	27.0	38.0	21.0	44.0	21.5	14.0	32	27	32	320
NC-ESWV-22LM 26x1,5 WD	718.2852.535.20	160	26x1.5	30x2.0	33.0	47.0	27.5	49.0	24.0	16.0	36	32	41	485
NC-ESWV-06SM 12x1,5 WD	718.2852.195.30	500	12x1.5	14x1.5	19.0	32.5	16.5	30.0	14.0	12.0	17	19	22	85
NC-ESWV-08SM 14x1,5 WD	718.2852.245.30	500	14x1.5	16x1.5	19.0	32.5	16.5	30.0	14.0	12.0	19	19	22	103
NC-ESWV-10SM 16x1,5 WD	718.2852.285.30	400	16x1.5	18x1.5	22.0	37.0	18.5	34.5	16.5	12.0	22	22	27	170
NC-ESWV-12SM 18x1,5 WD	718.2852.333.30	400	18x1.5	20x1.5	24.0	39.0	20.0	38.5	18.5	12.0	24	24	27	220
NC-ESWV-14SM 20x1,5 WD	718.2852.382.30	300	20x1.5	22x1.5	27.0	43.0	22.5	44.0	21.5	14.0	27	27	32	280
NC-ESWV-16SM 22x1,5 WD	718.2852.410.30	200	22x1.5	24x1.5	27.0	43.5	22.0	44.0	21.5	14.0	30	27	32	320
NC-ESWV-20SM 27x2,0 WD	718.2852.506.30	200	27x2.0	30x2.0	33.0	51.5	26.5	49.0	24.0	16.0	36	32	41	518
NC-ESWV-25SM 33x2,0 WD	718.2852.550.30	100	33x2.0	36x2.0	40.0	58.5	31.5	60.0	30.5	18.0	46	41	46	1030

Baumaße sind Ungefährmaße bei angezogener Überwurfmutter.

Sizes are approximate dimensions at tightened nut.

Las medidas son aproximadas con la tuerca de unión apretada.

Dichtungsmaterial: FKM (andere Werkstoffe auf Anfrage)

Sealing material: FKM (other materials on request)

Material de junta tórica: FKM (otros materiales bajo demanda)

M	10x1.0	12/14x1.5	16x1.5	18x1.5	20x1.5	22x1.5	26x1.5	27x2.0	33x2.0
[Nm]	15	25	45	60	110	80	150	160	210

Anzugsdrehmoment für HohlSchraube in Nm

Tightening torque for hollow bolt in Nm

Pares de apriete para tornillo hueco en Nm

Gerade Aufschraubverschraubungen
Straight female adaptor fittings
Racores atornillables rectos

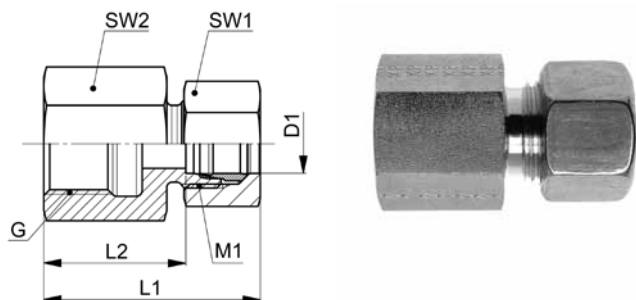

NC-GAV-..LR

Type-D1 G	Mat.-Nr.	PN	G	M1	L1	L2	SW1	SW2	g/Stk
G=Rohrgewinde (zylindrisch)			G=BSP thread (parallel)						
						G=rosca de conexión (cilíndrica)			
NC-GAV-06LR 1.8	718.1201.100.20	400	1/8	12x1.5	35.0	19.0	14	14	27
NC-GAV-06LR 1.4	718.1201.110.20	400	1/4	12x1.5	40.0	24.0	14	19	48
NC-GAV-08LR 1.4	718.1201.170.20	400	1/4	14x1.5	40.0	24.0	17	19	50
NC-GAV-08LR 3.8	718.1201.180.20	400	3/8	14x1.5	41.0	25.0	17	24	78
NC-GAV-08LR 1.2	718.1201.185.20	400	1/2	14x1.5	45.0	29.0	17	27	84
NC-GAV-10LR 1.4	718.1201.270.20	250	1/4	16x1.5	42.0	25.0	19	19	60
NC-GAV-10LR 3.8	718.1201.280.20	250	3/8	16x1.5	43.0	26.0	19	24	68
NC-GAV-10LR 1.2	718.1201.285.20	250	1/2	16x1.5	47.0	30.0	19	27	102
NC-GAV-12LR 1.4	718.1201.380.20	250	1/4	18x1.5	41.5	25.0	22	19	68
NC-GAV-12LR 3.8	718.1201.390.20	250	3/8	18x1.5	42.5	26.0	22	24	88
NC-GAV-12LR 1.2	718.1201.400.20	250	1/2	18x1.5	46.5	30.0	22	27	106
NC-GAV-15LR 3.8	718.1201.532.20	250	3/8	22x1.5	44.0	27.0	27	24	114
NC-GAV-15LR 1.2	718.1201.534.20	250	1/2	22x1.5	48.0	31.0	27	27	113
NC-GAV-18LR 3.8	718.1201.644.20	160	3/8	26x1.5	43.5	26.5	32	27	168
NC-GAV-18LR 1.2	718.1201.646.20	160	1/2	26x1.5	47.5	30.5	32	27	151
NC-GAV-22LR 3.4	718.1201.768.20	160	3/4	30x2.0	55.0	35.5	36	36	270

Baumaße sind Ungefährmaße bei angezogener Überwurfmutter.

Sizes are approximate dimensions at tightened nut.

Las medidas son aproximadas con la tuerca de unión apretada.

D1=Rohr außen-Ø
M1=metrisches Anschlußgewinde

D1=tube outside diameter
M1=metric connecting thread

D1=Ø exterior del tubo
M1=rosca métrica conexión

Gerade Aufschraubverschraubungen
Straight female adaptor fittings
Racores atornillables rectos

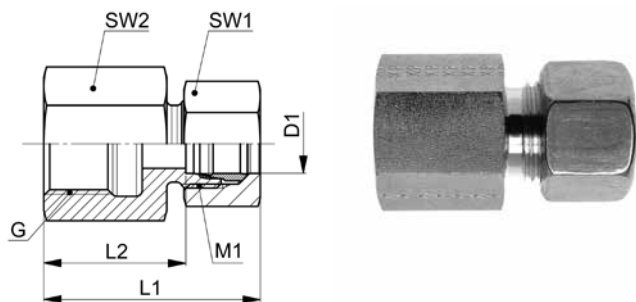

20

NC-GAV-..SR

Type-D1 G	Mat.-Nr.	PN	G	M1	L1	L2	SW1	SW2	g/Stk
G=Rohrgewinde (zylindrisch)			G=BSP thread (parallel)						
									G=rosca de conexión (cilíndrica)
NC-GAV-06SR 1.8	718.1201.100.30	500	1/8	14x1.5	37.0	21.0	17	17	50
NC-GAV-06SR 1.4	718.1201.110.30	500	1/4	14x1.5	42.0	26.0	17	19	49
NC-GAV-08SR 1.4	718.1201.170.30	500	1/4	16x1.5	42.0	26.0	19	19	59
NC-GAV-10SR 1.4	718.1201.270.30	400	1/4	18x1.5	45.0	26.5	22	22	114
NC-GAV-10SR 3.8	718.1201.280.30	400	3/8	18x1.5	45.0	26.5	22	24	100
NC-GAV-12SR 1.4	718.1201.380.30	400	1/4	20x1.5	46.5	27.0	24	22	106
NC-GAV-12SR 3.8	718.1201.390.30	400	3/8	20x1.5	45.5	26.5	24	24	112
NC-GAV-12SR 1.2	718.1201.400.30	400	1/2	20x1.5	49.5	30.5	24	27	122
NC-GAV-14SR 1.2	718.1201.504.30	300	1/2	22x1.5	52.5	32.0	27	27	148
NC-GAV-16SR 1.2	718.1201.566.30	200	1/2	24x1.5	53.0	31.5	30	27	175
NC-GAV-20SR 3.8	718.1201.703.30	200	3/8	30x2.0	54.5	27.5	36	32	245
NC-GAV-20SR 1.2	718.1201.706.30	200	1/2	30x2.0	59.5	34.5	36	32	248
NC-GAV-20SR 3.4	718.1201.708.30	200	3/4	30x2.0	59.5	34.5	36	36	300
NC-GAV-25SR 1.1	718.1201.810.30	100	1	36x2.0	65.0	37.5	46	41	466

Baumaße sind Ungefährmaße bei angezogener Überwurfmutter.

Sizes are approximate dimensions at tightened nut.

Las medidas son aproximadas con la tuerca de unión apretada.

D1=Rohr außen-Ø
M1=metrisches Anschlußgewinde

D1=tube outside diameter
M1=metric connecting thread

D1=Ø exterior del tubo
M1=rosca métrica conexión

Gerade Aufschraubverschraubungen
Straight female adaptor fittings
Racores atornillables rectos

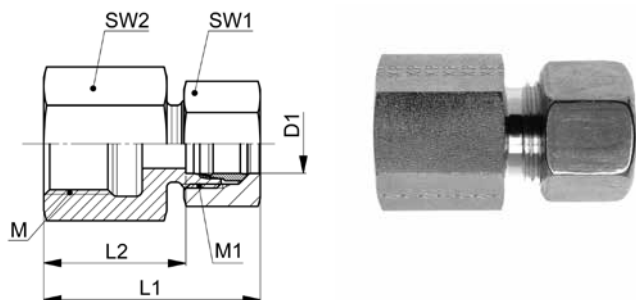

NC-GAV-..LM/SM

Type-D1 M	Mat.-Nr.	PN	M	M1	L1	L2	SW1	SW2	g/Stk
M=metrisches Gewinde (zylindrisch)		M=metric thread (parallel)				M=rosca métrica (cilindrica)			
NC-GAV-06LM 10x1,0	718.1204.180.20	400	10x1.0	12x1.5	35.5	19.5	14	14	26
NC-GAV-08LM 12x1,5	718.1204.240.20	400	12x1.5	14x1.5	40.0	24.0	17	17	50
NC-GAV-10LM 14x1,5	718.1204.280.20	250	14x1.5	16x1.5	42.0	25.0	19	19	50
NC-GAV-12LM 16x1,5	718.1204.330.20	250	16x1.5	18x1.5	42.5	26.0	22	22	90
NC-GAV-12LM 18x1,5	718.1204.333.20	250	18x1.5	18x1.5	44.5	28.0	22	24	95
NC-GAV-12LM 20x1,5	718.1204.335.20	250	20x1.5	18x1.5	44.5	28.0	22	27	110
NC-GAV-15LM 18x1,5	718.1204.390.20	250	18x1.5	22x1.5	45.0	28.0	27	24	115
NC-GAV-18LM 22x1,5	718.1204.460.20	160	22x1.5	26x1.5	46.5	29.5	32	30	157
NC-GAV-22LM 26x1,5	718.1204.535.20	160	26x1.5	30x2.0	54.0	34.5	36	32	215
NC-GAV-06SM 12x1,5	718.1204.190.30	500	12x1.5	14x1.5	42.0	26.0	17	17	54
NC-GAV-08SM 14x1,5	718.1204.198.30	500	14x1.5	16x1.5	42.0	26.0	19	19	69
NC-GAV-10SM 16x1,5	718.1204.285.30	400	16x1.5	18x1.5	45.0	26.5	22	22	102
NC-GAV-12SM 18x1,5	718.1204.333.30	400	18x1.5	20x1.5	46.5	27.5	24	24	110
NC-GAV-12SM 20x1,5	718.1204.335.30	400	20x1.5	20x1.5	48.5	29.5	24	27	125
NC-GAV-14SM 20x1,5	718.1204.382.30	300	20x1.5	22x1.5	51.5	31.0	27	27	148
NC-GAV-16SM 22x1,5	718.1204.410.30	200	22x1.5	24x1.5	52.0	30.5	30	30	175
NC-GAV-20SM 27x2,0	718.1204.506.30	200	27x2.0	30x2.0	59.5	34.5	36	36	307
NC-GAV-25SM 33x2,0	718.1204.550.30	100	33x2.0	36x2.0	64.0	37.0	46	41	466

Baumaße sind Ungefährmaße bei angezogener Überwurfmutter.

Sizes are approximate dimensions at tightened nut.

Las medidas son aproximadas con la tuerca de unión apretada.

Manometer-Anschlussverschraubungen

Abdichtung mit metallischem Dichtkantenring

Manometer fittings

sealing with metal seal-edge ring

Racores para manómetro

junta con anillo con borde de obturación metálico

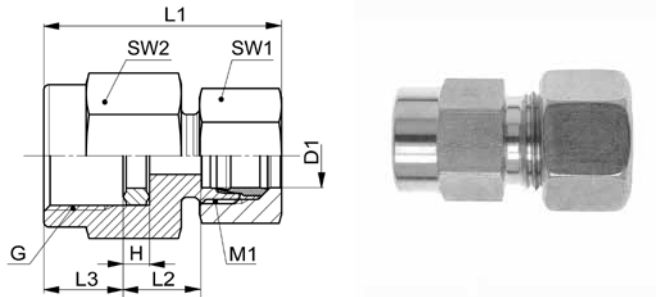

NC-MAV-..LR/SR

Type-D1 G	Mat.-Nr.	PN	G	M1	H	L1	L2	L3	SW1	SW2	g/Stk
G=Rohrgewinde (zylindrisch)		G=BSP thread (parallel)				G=rosca de conexión (cilíndrica)					
NC-MAV-06LR 1.4	718.0230.110.20	400	1/4	12x1.5	4.5	38.0	22.0	10.0	14	19	46
NC-MAV-08LR 1.4	718.0230.170.20	400	1/4	14x1.5	4.5	38.0	22.0	10.0	17	19	53
NC-MAV-10LR 1.4	718.0230.270.20	250	1/4	16x1.5	4.5	40.0	22.0	10.0	19	19	62
NC-MAV-12LR 1.4	718.0230.380.20	250	1/4	18x1.5	4.5	39.5	22.0	10.0	22	19	65
NC-MAV-12LR 1.2	718.0230.400.20	250	1/2	18x1.5	4.5	46.5	31.0	15.5	22	27	105
NC-MAV-06SR 1.4	718.0230.110.30	500	1/4	14x1.5	4.5	40.0	24.0	10.0	17	19	62
NC-MAV-06SR 1.2	718.0230.125.30	500	1/2	14x1.5	5.0	47.0	31.0	15.0	17	27	110
NC-MAV-08SR 1.4	718.0230.170.30	500	1/4	16x1.5	4.5	40.0	24.0	10.0	19	19	68
NC-MAV-08SR 1.2	718.0230.185.30	500	1/2	16x1.5	5.0	47.0	31.0	15.0	19	27	115
NC-MAV-10SR 1.2	718.0230.285.30	400	1/2	18x1.5	5.0	49.0	31.0	15.0	22	27	120
NC-MAV-12SR 1.2	718.0230.400.30	400	1/2	20x1.5	5.0	48.5	30.5	15.0	24	27	136
NC-MAV-14SR 1.2	718.0230.504.30	300	1/2	22x1.5	5.0	50.0	32.0	15.0	27	27	158

Baumaße sind Ungefährmaße bei angezogener Überwurfmutter.

Sizes are approximate dimensions at tightened nut.

Las medidas son aproximadas con la tuerca de unión apretada.

D1=Rohr außen-Ø
M1=metrisches Anschlußgewinde

D1=tube outside diameter
M1=metric connecting thread

D1=Ø exterior del tubo
M1=rosca métrica conexión

Manometer-Anschlussverschraubungen NPT
Manometer fittings NPT
Racores para manómetro NPT

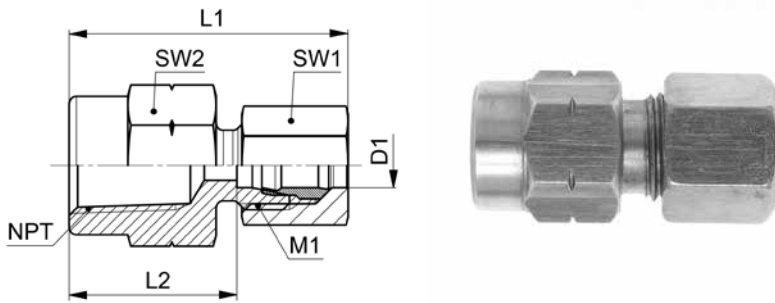

NC-MAV-..LNPT/SNPT

Type-D1 NPT	Mat.-Nr.	PN	NPT	M1	L1	L2	SW1	SW2	g/Stk
NPT=Einschraubgewinde NPT		NPT=tapered male adaptor thread NPT			NPT=rosca de conexión cónica NPT				
NC-MAV-06LNPT 1.4	718.0231.110.20	400	1/4	12x1.5	39.0	23.0	14	19	50
NC-MAV-06LNPT 1.2	718.0231.125.20	400	1/2	12x1.5	47.0	31.0	14	27	104
NC-MAV-08LNPT 1.4	718.0231.170.20	400	1/4	14x1.5	39.0	23.0	17	19	56
NC-MAV-08LNPT 1.2	718.0231.185.20	400	1/2	14x1.5	47.0	31.0	17	27	110
NC-MAV-10LNPT 1.4	718.0231.270.20	250	1/4	16x1.5	42.0	25.0	19	19	65
NC-MAV-10LNPT 1.2	718.0231.285.20	250	1/2	16x1.5	49.0	32.0	19	27	117
NC-MAV-12LNPT 1.4	718.0231.380.20	250	1/4	18x1.5	41.5	25.0	22	19	73
NC-MAV-12LNPT 1.2	718.0231.400.20	250	1/2	18x1.5	48.5	32.0	22	27	125
NC-MAV-06SNPT 1.2	718.0231.125.30	500	1/2	14x1.5	49.0	33.0	17	27	117
NC-MAV-08SNPT 1.2	718.0231.185.30	500	1/2	16x1.5	49.0	33.0	19	27	122
NC-MAV-12SNPT 1.2	718.0231.400.30	400	1/2	20x1.5	51.5	32.5	24	27	142

Baumaße sind Ungefährmaße bei angezogener Überwurfmutter.

Sizes are approximate dimensions at tightened nut.

Las medidas son aproximadas con la tuerca de unión apretada.

Gerade Messverschraubungen

mit Schraubkupplung M16x2 und O-Ring, Kegelausführung

Straight fittings with test gauge

with threaded connection M16x2 and O-ring, tapered version

Racores de medición rectos

con acoplamiento roscado M16x2 y junta tórica, versión cónico

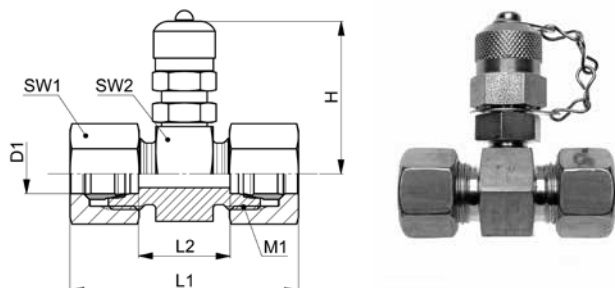

NC-EMV-GV-..L/S

Type-D1	Mat.-Nr.	PN	M1	H	L1	L2	SW1	SW2	g/Stk
NC-EMV-GV-06L	718.0240.060.20	400	12x1.5	49.0	52.5	20.0	14	24	149
NC-EMV-GV-08L	718.0240.080.20	400	14x1.5	49.0	52.5	20.0	17	24	161
NC-EMV-GV-10L	718.0240.100.20	250	16x1.5	49.0	56.5	22.0	19	24	175
NC-EMV-GV-12L	718.0240.120.20	250	18x1.5	49.0	55.5	22.0	22	24	186
NC-EMV-GV-15L	718.0240.150.20	250	22x1.5	52.0	58.5	24.0	27	30	261
NC-EMV-GV-18L	718.0240.180.20	160	26x1.5	53.0	57.5	23.0	32	32	323
NC-EMV-GV-22L	718.0240.220.20	160	30x2.0	55.0	66.5	27.0	36	36	396
NC-EMV-GV-06S	718.0240.060.30	500	14x1.5	49.0	56.5	24.0	17	24	172
NC-EMV-GV-08S	718.0240.080.30	500	16x1.5	49.0	56.5	24.0	19	24	182
NC-EMV-GV-10S	718.0240.100.30	400	18x1.5	49.0	60.5	23.0	22	24	207
NC-EMV-GV-12S	718.0240.120.30	400	20x1.5	49.0	61.5	23.0	24	24	223
NC-EMV-GV-14S	718.0240.140.30	300	22x1.5	50.0	67.5	26.0	27	27	284
NC-EMV-GV-16S	718.0240.160.30	200	24x1.5	52.0	68.5	25.0	30	30	327
NC-EMV-GV-20S	718.0240.200.30	200	30x2.0	55.0	75.5	25.0	36	36	478
NC-EMV-GV-25S	718.0240.250.30	100	36x2.0	57.0	80.5	26.0	46	41	776

Baumaße sind Ungefährmaße bei angezogener Überwurfmutter.

Sizes are approximate dimensions at tightened nut.

Las medidas son aproximadas con la tuerca de unión apretada.

mit O-Ring-Dichtung am Einschraubgewinde
Dichtungsmaterial: FKM (andere Werkstoffe auf Anfrage)

with O-ring-seal on male adaptor thread
Sealing material: FKM (other materials on request)

Junta tórica en la rosca
Material de junta tórica: FKM (otros materiales bajo demanda)

D1=Rohr außen-Ø
M1=metrisches Anschlußgewinde

D1=tube outside diameter
M1=metric connecting thread

D1=Ø exterior del tubo
M1=rosca métrica conexión

Reduzierschraubungen mit Dichtkegel und O-Ring

Reducing fittings with taper and O-ring

Racores de reducción con junta cónica y junta tórica

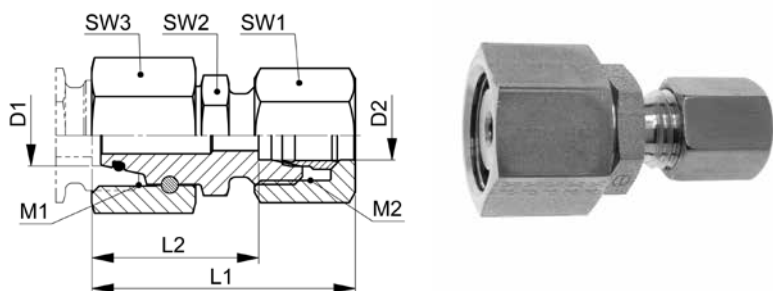

NC-GRKO..L

Type -D1 /D2	Mat.-Nr.	PN	M1	M2	L1	L2	SW1	SW2	SW3	g/Stk
NC-GRKO-08/06L	718.1870.140.20	315	14x1.5	12x1.5	39.5	23.0	14	12	17	42
NC-GRKO-10/06L	718.1870.175.20	315	16x1.5	12x1.5	41.0	25.0	14	14	19	54
NC-GRKO-10/08L	718.1870.190.20	315	16x1.5	14x1.5	41.0	25.0	17	14	19	56
NC-GRKO-12/06L	718.1870.215.20	315	18x1.5	12x1.5	41.0	25.0	14	17	22	68
NC-GRKO-12/08L	718.1870.225.20	315	18x1.5	14x1.5	41.0	25.0	17	17	22	72
NC-GRKO-12/10L	718.1870.240.20	250	18x1.5	16x1.5	43.0	26.0	19	17	22	74
NC-GRKO-15/06L	718.1870.391.20	315	22x1.5	12x1.5	44.5	28.5	14	22	27	100
NC-GRKO-15/08L	718.1870.400.20	315	22x1.5	14x1.5	44.5	28.5	17	22	27	118
NC-GRKO-15/10L	718.1870.410.20	250	22x1.5	16x1.5	46.0	29.0	19	22	27	118
NC-GRKO-15/12L	718.1870.420.20	250	22x1.5	18x1.5	45.5	29.0	22	22	27	122
NC-GRKO-18/06L	718.1870.563.20	315	26x1.5	12x1.5	44.0	28.0	14	24	32	122
NC-GRKO-18/08L	718.1870.570.20	315	26x1.5	14x1.5	44.0	28.0	17	24	32	132
NC-GRKO-18/10L	718.1870.575.20	250	26x1.5	16x1.5	46.0	29.0	19	24	32	150
NC-GRKO-18/12L	718.1870.580.20	250	26x1.5	18x1.5	45.5	29.0	22	24	32	152
NC-GRKO-18/15L	718.1870.610.20	250	26x1.5	22x1.5	47.0	30.0	27	24	32	170
NC-GRKO-22/06L	718.1870.723.20	160	30x2.0	12x1.5	48.0	32.0	14	27	36	178
NC-GRKO-22/08L	718.1870.724.20	160	30x2.0	14x1.5	48.0	32.0	17	27	36	180
NC-GRKO-22/10L	718.1870.725.20	250	30x2.0	16x1.5	50.0	33.0	19	27	36	186
NC-GRKO-22/12L	718.1870.730.20	160	30x2.0	18x1.5	49.5	33.0	22	27	36	194
NC-GRKO-22/15L	718.1870.745.20	160	30x2.0	22x1.5	51.0	34.0	27	27	36	236
NC-GRKO-22/18L	718.1870.755.20	160	30x2.0	26x1.5	50.5	33.5	32	27	36	250
NC-GRKO-28/06L	718.1870.828.20	160	36x2.0	12x1.5	50.0	34.0	14	36	41	322
NC-GRKO-28/08L	718.1870.829.20	160	36x2.0	14x1.5	50.0	34.0	17	36	41	315
NC-GRKO-28/10L	718.1870.830.20	160	36x2.0	16x1.5	52.0	35.0	19	36	41	320
NC-GRKO-28/12L	718.1870.835.20	160	36x2.0	18x1.5	51.5	35.0	22	36	41	328
NC-GRKO-28/15L	718.1870.865.20	160	36x2.0	22x1.5	53.0	36.0	27	36	41	350
NC-GRKO-28/18L	718.1870.870.20	160	36x2.0	26x1.5	52.5	35.5	32	36	41	317
NC-GRKO-28/22L	718.1870.900.20	160	36x2.0	30x2.0	57.0	37.5	36	36	41	420

Fortsetzung nächste Seite

Continued on next page

Continuación página próxima

Reduzierschraubungen mit Dichtkegel und O-Ring
Reducing fittings with taper and O-ring
Racores de reducción con junta cónica y junta tórica

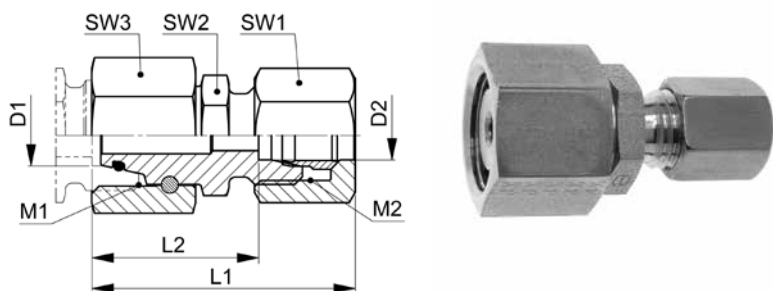

NC-GRKO..L

Type -D1 /D2	Mat.-Nr.	PN	M1	M2	L1	L2	SW1	SW2	SW3	g/Stk
NC-GRKO-35/06L	718.1870.951.20	160	45x2.0	12x1.5	53.0	37.0	14	46	50	372
NC-GRKO-35/08L	718.1870.952.20	160	45x2.0	14x1.5	53.0	37.0	17	46	50	388
NC-GRKO-35/10L	718.1870.953.20	160	45x2.0	16x1.5	55.0	38.0	19	46	50	362
NC-GRKO-35/12L	718.1870.954.20	160	45x2.0	18x1.5	54.5	38.0	22	46	50	378
NC-GRKO-35/15L	718.1870.946.20	160	45x2.0	22x1.5	56.0	39.0	27	46	50	404
NC-GRKO-35/18L	718.1870.947.20	160	45x2.0	26x1.5	55.5	38.5	32	46	50	432
NC-GRKO-35/22L	718.1870.948.20	160	45x2.0	30x2.0	60.0	40.5	36	46	50	454
NC-GRKO-42/06L	718.1870.949.20	160	52x2.0	12x1.5	56.5	40.5	14	46	50	504
NC-GRKO-42/08L	718.1870.986.20	160	52x2.0	14x1.5	56.5	40.5	17	50	60	552
NC-GRKO-42/10L	718.1870.987.20	160	52x2.0	16x1.5	58.5	41.5	19	50	60	558
NC-GRKO-42/12L	718.1870.988.20	160	52x2.0	18x1.5	58.0	41.5	22	50	60	570
NC-GRKO-42/15L	718.1870.989.20	160	52x2.0		59.5	42.5	27	50	60	582
NC-GRKO-42/18L	718.1870.991.20	160	52x2.0		59.0	42.0	32	50	60	600
NC-GRKO-42/22L	718.1870.993.20	160	52x2.0		63.5	44.0	36	50	60	628

Baumaße sind Ungefährmaße bei angezogener Überwurfmutter.

Sizes are approximate dimensions at tightened nut.

Las medidas son aproximadas con la tuerca de unión apretada.

Dichtungsmaterial: FKM (andere Werkstoffe auf Anfrage)

Sealing material: FKM (other materials on request)

Material de junta tórica: FKM (otros materiales bajo demanda)

Reduzierschraubungen mit Dichtkegel und O-Ring

Reducing fittings with taper and O-ring

Racores de reducción con junta cónica y junta tórica

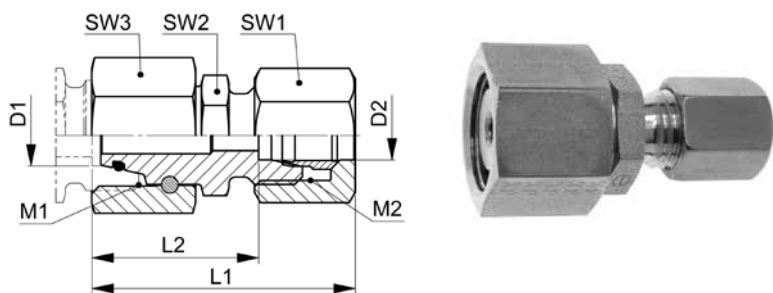

NC-GRKO..S

Type -D1 /D2	Mat.-Nr.	PN	M1	M2	L1	L2	SW1	SW2	SW3	g/Stk
NC-GRKO-08/06S	718.1870.140.30	500	16x1.5	14x1.5	43.0	27.0	17	14	19	64
NC-GRKO-10/06S	718.1870.175.30	500	18x1.5	14x1.5	44.5	27.0	17	17	22	78
NC-GRKO-10/08S	718.1870.190.30	500	18x1.5	16x1.5	43.5	27.0	19	17	22	82
NC-GRKO-12/06S	718.1870.215.30	500	20x1.5	14x1.5	46.0	30.0	17	19	24	98
NC-GRKO-12/08S	718.1870.225.30	500	20x1.5	16x1.5	46.0	30.0	19	19	24	100
NC-GRKO-12/10S	718.1870.240.30	400	20x1.5	18x1.5	48.0	29.0	22	19	24	112
NC-GRKO-14/06S	718.1870.296.30	500	22x1.5	14x1.5	47.5	31.0	17	22	27	132
NC-GRKO-14/08S	718.1870.300.30	500	22x1.5	16x1.5	47.5	31.5	19	22	27	136
NC-GRKO-14/10S	718.1870.320.30	400	22x1.5	18x1.5	49.5	31.0	22	22	27	146
NC-GRKO-14/12S	718.1870.340.30	400	22x1.5	20x1.5	50.0	31.0	24	22	27	148
NC-GRKO-16/06S	718.1870.466.30	400	24x1.5	14x1.5	48.0	32.0	17	22	30	128
NC-GRKO-16/08S	718.1870.468.30	400	24x1.5	16x1.5	48.0	32.0	19	22	30	134
NC-GRKO-16/10S	718.1870.470.30	400	24x1.5	18x1.5	50.0	31.0	22	22	30	156
NC-GRKO-16/12S	718.1870.480.30	400	24x1.5	20x1.5	50.5	31.0	24	22	30	160
NC-GRKO-16/14S	718.1870.500.30	300	24x1.5	22x1.5	53.5	33.0	27	22	30	184
NC-GRKO-20/06S	718.1870.650.30	400	30x2.0	14x1.5	52.0	36.0	17	27	36	206
NC-GRKO-20/08S	718.1870.655.30	400	30x2.0	16x1.5	52.0	36.0	19	27	36	198
NC-GRKO-20/10S	718.1870.660.30	400	30x2.0	18x1.5	54.0	35.5	22	27	36	210
NC-GRKO-20/12S	718.1870.665.30	400	30x2.0	20x1.5	54.5	35.5	24	27	36	238
NC-GRKO-20/14S	718.1870.675.30	300	30x2.0	22x1.5	57.5	37.0	27	27	36	258
NC-GRKO-20/16S	718.1870.685.30	200	30x2.0	24x1.5	58.0	36.5	30	27	36	264
NC-GRKO-25/06S	718.1870.788.30	400	36x2.0	14x1.5	54.5	38.5	17	36	46	356
NC-GRKO-25/08S	718.1870.787.30	400	36x2.0	16x1.5	54.5	38.5	19	36	46	362
NC-GRKO-25/10S	718.1870.789.30	400	36x2.0	18x1.5	56.5	38.0	22	36	46	352
NC-GRKO-25/12S	718.1870.791.30	400	36x2.0	20x1.5	57.0	38.0	24	36	46	356
NC-GRKO-25/14S	718.1870.790.30	300	36x2.0	22x1.5	60.0	39.5	27	36	46	374
NC-GRKO-25/16S	718.1870.800.30	200	36x2.0	24x1.5	60.5	39.0	30	36	46	394
NC-GRKO-25/20S	718.1870.820.30	200	36x2.0	30x2.0	64.0	39.0	36	36	46	458

Fortsetzung nächste Seite

Continued on next page

Continuación página próxima

Reduzierschraubungen mit Dichtkegel und O-Ring
Reducing fittings with taper and O-ring
Racores de reducción con junta cónica y junta tórica

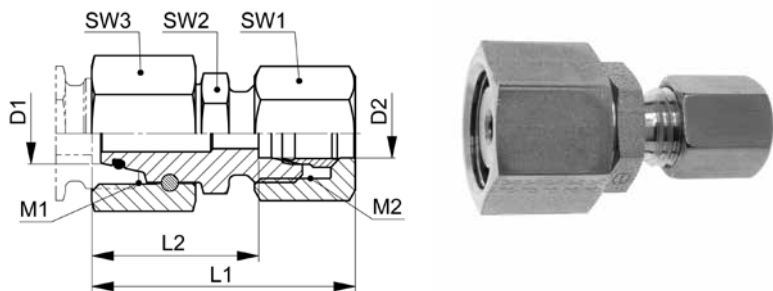

20

NC-GRKO..S

Type -D1 /D2	Mat.-Nr.	PN	M1	M2	L1	L2	SW1	SW2	SW3	g/Stk
NC-GRKO-30/06S	718.1870.937.30	400	42x2.0	14x1.5	60.0	43.5	17	41	50	412
NC-GRKO-30/08S	718.1870.936.30	400	42x2.0	16x1.5	60.0	43.5	19	41	50	416
NC-GRKO-30/10S	718.1870.939.30	400	42x2.0	18x1.5	62.0	43.0	22	41	50	424
NC-GRKO-30/12S	718.1870.940.30	400	42x2.0	20x1.5	62.5	43.0	24	41	50	432
NC-GRKO-30/14S	718.1870.941.30	300	42x2.0	22x1.5	65.5	44.5	27	41	50	480
NC-GRKO-30/16S	718.1870.942.30	200	42x2.0	24x1.5	66.0	44.0	30	41	50	468
NC-GRKO-30/20S	718.1870.943.30	200	42x2.0	30x2.0	69.5	44.0	36	41	50	528
NC-GRKO-30/25S	718.1870.945.30	100	42x2.0	36x2.0	72.0	44.5	46	41	50	672
NC-GRKO-38/06S	718.1870.965.30	315	52x2.0	14x1.5	63.0	47.0	17	50	60	574
NC-GRKO-38/08S	718.1870.966.30	315	52x2.0	16x1.5	63.0	47.0	19	50	60	578
NC-GRKO-38/10S	718.1870.967.30	315	52x2.0	18x1.5	65.0	46.5	22	50	60	632
NC-GRKO-38/12S	718.1870.968.30	315	52x2.0	20x1.5	65.5	46.5	24	50	60	638
NC-GRKO-38/14S	718.1870.969.30	300	52x2.0	22x1.5	68.5	48.0	27	50	60	652
NC-GRKO-38/16S	718.1870.970.30	200	52x2.0	24x1.5	69.0	47.5	30	50	60	672
NC-GRKO-38/20S	718.1870.971.30	200	52x2.0	30x2.0	72.5	47.5	36	50	60	682
NC-GRKO-38/25S	718.1870.972.30	100	52x2.0	36x2.0	75.0	48.5	46	50	60	818

Baumaße sind Ungefährmaße bei angezogener Überwurfmutter.

Sizes are approximate dimensions at tightened nut.

Las medidas son aproximadas con la tuerca de unión apretada.

Dichtungsmaterial: FKM (andere Werkstoffe auf Anfrage)

Sealing material: FKM (other materials on request)

Material de junta tórica: FKM (otros materiales bajo demanda)

Gerade Reduzierschraubungen

Straight reducing fittings

Racores de reducción rectos

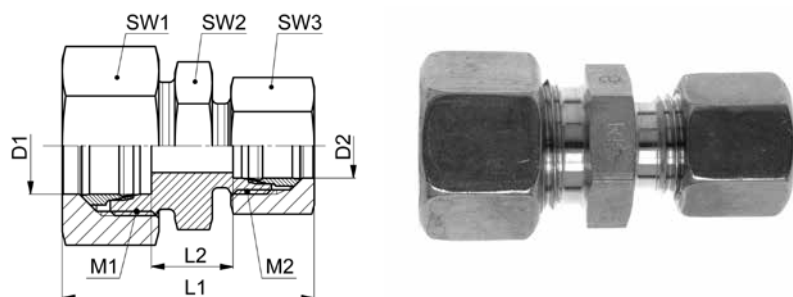

NC-GR..L

Type-D1 /D2	Mat.-Nr.	PN	M1	M2	L1	L2	SW1	SW2	SW3	g/Stk
NC-GR-08/06L	718.1024.140.20	400	14x1.5	12x1.5	43.0	11.0	17	14	14	51
NC-GR-10/06L	718.1024.175.20	250	16x1.5	12x1.5	45.0	12.0	19	17	14	58
NC-GR-10/08L	718.1024.190.20	250	16x1.5	14x1.5	45.0	12.0	19	17	17	58
NC-GR-12/06L	718.1024.215.20	250	18x1.5	12x1.5	45.5	13.0	22	19	14	63
NC-GR-12/08L	718.1024.225.20	250	18x1.5	14x1.5	45.5	13.0	22	19	17	70
NC-GR-12/10L	718.1024.240.20	250	18x1.5	16x1.5	47.5	14.0	22	19	19	80
NC-GR-15/06L	718.1024.391.20	250	22x1.5	12x1.5	47.0	14.0	27	24	14	100
NC-GR-15/08L	718.1024.400.20	250	22x1.5	14x1.5	47.0	14.0	27	24	17	105
NC-GR-15/10L	718.1024.410.20	250	22x1.5	16x1.5	49.0	15.0	27	24	19	110
NC-GR-15/12L	718.1024.420.20	250	22x1.5	18x1.5	48.5	15.0	27	24	22	132
NC-GR-18/08L	718.1024.570.20	160	26x1.5	14x1.5	47.5	14.5	32	27	17	115
NC-GR-18/10L	718.1024.575.20	160	26x1.5	16x1.5	49.5	15.5	32	27	19	145
NC-GR-18/12L	718.1024.580.20	160	26x1.5	18x1.5	49.0	15.5	32	27	22	175
NC-GR-18/15L	718.1024.610.20	160	26x1.5	22x1.5	50.5	16.5	32	27	27	175
NC-GR-22/08L	718.1024.724.20	160	30x2.0	14x1.5	52.0	16.5	36	32	17	210
NC-GR-22/10L	718.1024.725.20	160	30x2.0	16x1.5	54.0	17.5	36	32	19	198
NC-GR-22/12L	718.1024.730.20	160	30x2.0	18x1.5	53.5	17.5	36	32	22	200
NC-GR-22/15L	718.1024.745.20	160	30x2.0	22x1.5	55.0	18.5	36	32	27	220
NC-GR-22/18L	718.1024.755.20	160	30x2.0	26x1.5	54.5	18.0	36	32	32	274

Baumaße sind Ungefährmaße bei angezogener Überwurfmutter.

Sizes are approximate dimensions at tightened nut.

Las medidas son aproximadas con la tuerca de unión apretada.

Gerade Reduzierschraubungen

Straight reducing fittings

Racores de reducción rectos

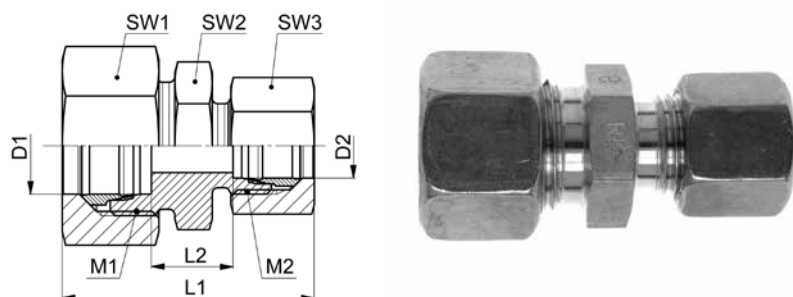

20

NC-GR-..S

Type-D1 /D2	Mat.-Nr.	PN	M1	M2	L1	L2	SW1	SW2	SW3	g/Stk
NC-GR-08/06S	718.1024.140.30	500	16x1.5	14x1.5	50.0	18.0	19	17	17	85
NC-GR-10/06S	718.1024.175.30	400	18x1.5	14x1.5	52.0	17.5	22	19	17	95
NC-GR-10/08S	718.1024.190.30	400	18x1.5	16x1.5	52.0	17.5	22	19	19	100
NC-GR-12/06S	718.1024.215.30	400	20x1.5	14x1.5	54.5	19.5	24	22	17	105
NC-GR-12/08S	718.1024.225.30	400	20x1.5	16x1.5	54.5	19.5	24	22	19	115
NC-GR-12/10S	718.1024.240.30	400	20x1.5	18x1.5	56.5	19.0	24	22	22	125
NC-GR-14/06S	718.1024.296.30	300	22x1.5	14x1.5	57.5	21.0	27	24	17	125
NC-GR-14/08S	718.1024.300.30	300	22x1.5	16x1.5	57.5	21.0	27	24	19	140
NC-GR-14/10S	718.1024.320.30	300	22x1.5	18x1.5	59.5	20.0	27	24	22	125
NC-GR-14/12S	718.1024.340.30	300	22x1.5	20x1.5	60.0	20.0	27	24	24	165
NC-GR-16/06S	718.1024.466.30	200	24x1.5	14x1.5	58.0	20.5	30	27	17	170
NC-GR-16/08S	718.1024.468.30	200	24x1.5	16x1.5	58.0	20.5	30	27	19	180
NC-GR-16/10S	718.1024.470.30	200	24x1.5	18x1.5	60.0	20.0	30	27	22	185
NC-GR-16/12S	718.1024.480.30	200	24x1.5	20x1.5	60.5	20.0	30	27	24	190
NC-GR-16/14S	718.1024.500.30	200	24x1.5	22x1.5	63.5	21.5	30	27	27	215
NC-GR-20/06S	718.1024.650.30	200	30x2.0	14x1.5	63.5	22.5	36	32	17	230
NC-GR-20/08S	718.1024.655.30	200	30x2.0	16x1.5	63.5	22.5	36	32	19	250
NC-GR-20/10S	718.1024.660.30	200	30x2.0	18x1.5	65.5	22.0	36	32	22	270
NC-GR-20/12S	718.1024.665.30	200	30x2.0	20x1.5	66.0	22.0	36	32	24	280
NC-GR-20/14S	718.1024.675.30	200	30x2.0	22x1.5	69.0	23.5	36	32	27	300
NC-GR-20/16S	718.1024.685.30	200	30x2.0	24x1.5	69.5	23.0	36	32	30	315
NC-GR-25/06S	718.1024.788.30	100	36x2.0	14x1.5	68.0	25.0	46	41	17	491
NC-GR-25/08S	718.1024.787.30	100	36x2.0	16x1.5	68.0	25.0	46	41	19	495
NC-GR-25/10S	718.1024.789.30	100	36x2.0	18x1.5	70.0	24.5	46	41	22	480
NC-GR-25/12S	718.1024.791.30	100	36x2.0	20x1.5	70.5	26.0	46	41	24	500
NC-GR-25/14S	718.1024.790.30	100	36x2.0	22x1.5	73.5	24.5	46	41	27	545
NC-GR-25/16S	718.1024.800.30	100	36x2.0	24x1.5	74.0	25.5	46	41	30	552
NC-GR-25/20S	718.1024.820.30	100	36x2.0	30x2.0	77.5	25.5	46	41	36	564

Baumaße sind Ungefährmaße bei angezogener Überwurfmutter.

Sizes are approximate dimensions at tightened nut.

Las medidas son aproximadas con la tuerca de unión apretada.

D1/D2=Rohr außen-Ø
M1/M2=metrische Anschlußgewinde

D1/D2=tube outside diameter
M1/M2=metric connecting threads

D1/D2=Ø exterior del tubo
M1/M2=rosca métrica conexión

T-Reduzierschraubungen

Reducing T fittings

Racores de reducción T

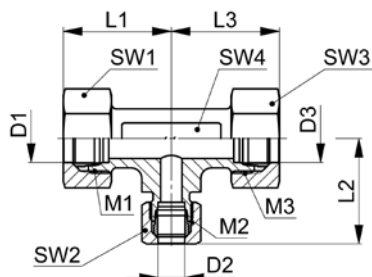

NC-TR-..L/S

Type-D1 /D2 /D3	Mat.-Nr.	PN	M1	M2	M3	L1	L2	L3	SW1	SW2	SW3	SW4	g/Stk
NC-TR-06/08/06L	718.3004.058.20	400	12x1.5	14x1.5	12x1.5	30.0	30.0	30.0	14	17	14	12	82
NC-TR-06/10/06L	718.3004.061.20	250	12x1.5	16x1.5	12x1.5	31.0	32.5	31.0	14	19	14	14	97
NC-TR-08/06/08L	718.3004.093.20	400	14x1.5	12x1.5	14x1.5	30.0	30.0	30.0	17	14	17	12	80
NC-TR-08/10/08L	718.3004.104.20	250	14x1.5	16x1.5	14x1.5	31.0	32.5	31.0	17	19	17	14	109
NC-TR-10/06/10L	718.3004.147.20	250	16x1.5	12x1.5	16x1.5	32.5	31.0	32.5	19	14	19	14	100
NC-TR-10/08/10L	718.3004.153.20	250	16x1.5	14x1.5	16x1.5	32.5	31.0	32.5	19	17	19	14	113
NC-TR-10/10/08L	718.3004.160.20	250	16x1.5	16x1.5	14x1.5	32.5	32.0	31.5	19	19	17	14	113
NC-TR-10/15/10L	718.3004.175.20	250	16x1.5	22x1.5	16x1.5	38.5	39.0	38.5	19	27	19	19	208
NC-TR-12/08/12L	718.3004.210.20	250	18x1.5	14x1.5	18x1.5	34.0	33.0	34.0	22	17	22	17	145
NC-TR-12/10/12L	718.3004.222.20	250	18x1.5	16x1.5	18x1.5	34.0	34.5	34.0	22	19	22	17	150
NC-TR-12/12/10L	718.3004.232.20	250	18x1.5	18x1.5	16x1.5	34.0	34.0	34.5	22	22	19	17	150
NC-TR-12/18/12L	718.3004.258.20	160	18x1.5	26x1.5	18x1.5	41.0	41.0	41.0	22	32	22	24	276
NC-TR-15/10/15L	718.3004.410.20	250	22x1.5	16x1.5	22x1.5	37.0	37.0	37.0	27	19	27	19	222
NC-TR-15/12/12L	718.3004.417.20	250	22x1.5	18x1.5	18x1.5	38.0	37.5	37.5	27	22	22	19	240
NC-TR-15/12/15L	718.3004.422.20	250	22x1.5	18x1.5	22x1.5	38.0	37.5	38.0	27	22	27	19	240
NC-TR-15/15/12L	718.3004.435.20	250	22x1.5	22x1.5	18x1.5	38.0	38.0	37.5	27	27	22	19	227
NC-TR-18/10/10L	718.3004.575.20	250	26x1.5	16x1.5	16x1.5	41.0	41.0	41.5	32	19	19	24	310
NC-TR-18/10/18L	718.3004.584.20	160	26x1.5	16x1.5	26x1.5	41.0	41.5	41.0	32	19	32	24	328
NC-TR-18/12/18L	718.3004.599.20	160	26x1.5	18x1.5	26x1.5	41.0	41.0	41.0	32	22	32	24	341
NC-TR-18/15/18L	718.3004.628.20	160	26x1.5	22x1.5	26x1.5	40.5	41.0	40.5	32	27	32	24	344
NC-TR-18/18/10L	718.3004.637.20	160	26x1.5	26x1.5	16x1.5	41.0	41.0	41.5	32	32	19	24	351
NC-TR-22/10/22L	718.3004.738.20	160	30x2.0	16x1.5	30x2.0	47.5	45.5	47.5	36	19	36	27	486
NC-TR-22/12/22L	718.3004.740.20	160	30x2.0	18x1.5	30x2.0	47.5	45.0	47.5	36	22	36	27	494
NC-TR-22/15/22L	718.3004.800.20	160	30x2.0	22x1.5	30x2.0	47.5	46.0	47.5	36	27	36	27	513
NC-TR-22/18/18L	718.3004.854.20	160	30x2.0	26x1.5	26x1.5	47.0	43.5	44.0	36	32	32	27	480
NC-TR-22/18/22L	718.3004.862.20	160	30x2.0	26x1.5	30x2.0	47.5	45.0	47.5	36	32	36	27	506
NC-TR-12/16/12S	718.3004.256.30	200	20x1.5	24x1.5	20x1.5	45.0	47.0	45.0	24	30	24	24	313
NC-TR-16/10/16S	718.3004.454.30	200	24x1.5	18x1.5	24x1.5	47.0	44.5	47.0	30	22	30	24	419
NC-TR-16/12/16S	718.3004.455.30	200	24x1.5	20x1.5	24x1.5	47.0	45.0	47.0	30	24	30	24	314
NC-TR-20/10/20S	718.3004.675.30	200	30x2.0	16x1.5	30x2.0	51.5	48.0	51.5	36	22	36	27	552
NC-TR-20/12/20S	718.3004.680.30	200	30x2.0	20x1.5	30x2.0	53.0	52.0	46.0	36	24	36	27	580
NC-TR-25/16/25S	718.3004.900.30	100	36x2.0	24x1.5	36x2.0	58.5	56.0	58.5	46	30	46	36	1050

Baumaße sind Ungefährmaße bei angezogener Überwurfmutter.

Sizes are approximate dimensions at tightened nut.

Las medidas son aproximadas con la tuerca de unión apretada.

D1/D2/D3=Rohr außen-Ø
M1/M2/M3=metrische Anschlußgewinde

D1/D2/D3=tube outside diameter
M1/M2/M3=metric connecting threads

D1/D2/D3=Ø exterior del tubo
M1/M2/M3=rosca métrica conexión

Gerade Anschweißverschraubungen
Straight weld-on fittings
Racores para soldar rectos

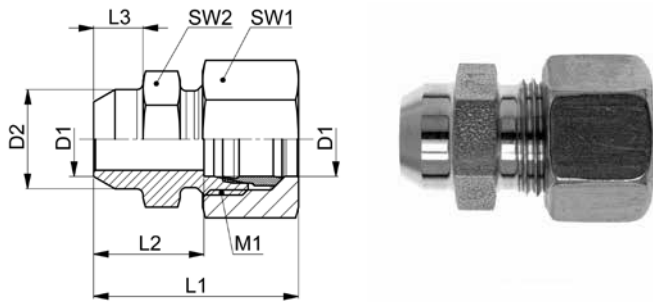

20

NC-GAS-..L/S

Type -D1	Mat.-Nr.	PN	M1	D2	L1	L2	L3	SW1	SW2	g/Stk
NC-GAS-06L	718.1400.060.20	400	12x1.5	10.0	30.0	14.0	7.0	14	12	25
NC-GAS-08L	718.1400.080.20	400	14x1.5	12.0	32.0	16.0	8.0	17	14	36
NC-GAS-10L	718.1400.100.20	250	16x1.5	14.0	35.0	18.0	8.0	19	17	47
NC-GAS-12L	718.1400.120.20	250	18x1.5	16.0	34.5	18.0	8.0	22	19	55
NC-GAS-15L	718.1400.150.20	250	22x1.5	19.0	39.0	22.0	10.0	27	22	90
NC-GAS-18L	718.1400.180.20	160	26x1.5	22.0	40.5	23.5	10.0	32	27	130
NC-GAS-22L	718.1400.220.20	160	30x2.0	27.0	48.0	28.5	12.0	36	32	190
NC-GAS-06S	718.1400.060.30	500	14x1.5	11.0	35.0	19.0	7.0	17	14	38
NC-GAS-08S	718.1400.080.30	500	16x1.5	13.0	37.0	21.0	8.0	19	17	54
NC-GAS-10S	718.1400.100.30	400	18x1.5	15.0	41.0	22.5	8.0	22	19	70
NC-GAS-12S	718.1400.120.30	400	20x1.5	17.0	43.5	24.5	10.0	24	22	125
NC-GAS-14S	718.1400.140.30	300	22x1.5	19.0	47.5	27.0	10.0	27	24	140
NC-GAS-16S	718.1400.160.30	200	24x1.5	21.0	48.0	26.5	10.0	30	27	156
NC-GAS-20S	718.1400.200.30	200	30x2.0	26.0	54.5	29.5	12.0	36	32	240
NC-GAS-25S	718.1400.250.30	100	36x2.0	31.0	59.0	32.0	12.0	46	41	460

Baumaße sind Ungefährmaße bei angezogener Überwurfmutter.

Sizes are approximate dimensions at tightened nut.

Las medidas son aproximadas con la tuerca de unión apretada.

Nach dem Anschweißen die in der Montageanleitung angegebenen Stellen nochmals mit der ASW Fettpaste schmieren (Klemmring, Gewinde der Mutter).

After welding, coat the parts indicated in the assembly instructions with ASW grease (clamping ring, thread of nut).

Luego de soldar, aplique nuevamente la grasa ASW en las partes indicadas en las instrucciones de montaje (anillo de apriete NC, roscas de tuercas).

D1=Rohraußen-Ø
M1=metrisches Anschlußgewinde

D1=tube outside diameter
M1=metric connecting thread

D1=Ø exterior del tubo
M1=rosca métrica conexión

Winkelanschweißverschraubungen

Elbow weld-on fittings

Racores para soldar angulares

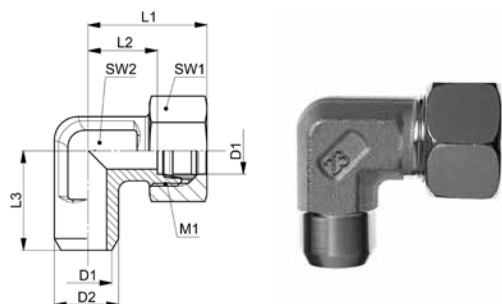

NC-WAS-..L/S

Type -D1	Mat.-Nr.	PN	M1	D2	L1	L2	L3	SW1	SW2	g/Stk
NC-WAS-06L	718.2400.060.20	400	12x1.5	10.0	28.0	15.0	19.0	14	12	34
NC-WAS-08L	718.2400.080.20	400	14x1.5	12.0	30.0	15.0	23.0	17	12	47
NC-WAS-10L	718.2400.100.20	250	16x1.5	14.0	32.5	15.5	24.0	19	14	61
NC-WAS-12L	718.2400.120.20	250	18x1.5	16.0	34.0	15.5	25.0	22	17	78
NC-WAS-15L	718.2400.150.20	250	22x1.5	19.0	39.0	16.0	30.0	27	19	127
NC-WAS-18L	718.2400.180.20	160	26x1.5	22.0	41.0	17.0	33.0	32	24	204
NC-WAS-22L	718.2400.220.20	160	30x2.0	27.0	47.5	17.0	37.0	36	27	261
NC-WAS-06S	718.2400.060.30	500	14x1.5	11.0	32.0	15.0	23.0	17	12	54
NC-WAS-08S	718.2400.080.30	500	16x1.5	13.0	33.0	15.0	24.0	19	14	71
NC-WAS-10S	718.2400.100.30	450	18x1.5	15.0	36.5	17.0	25.0	22	17	96
NC-WAS-12S	718.2400.120.30	400	20x1.5	17.0	41.0	17.0	29.0	24	17	123
NC-WAS-14S	718.2400.140.30	300	22x1.5	19.0	43.0	18.5	30.0	27	19	154
NC-WAS-16S	718.2400.160.30	200	24x1.5	21.0	47.0	19.5	33.0	30	24	230
NC-WAS-20S	718.2400.200.30	200	30x2.0	26.0	53.0	23.0	37.0	36	27	327
NC-WAS-25S	718.2400.250.30	100	36x2.0	31.0	58.5	25.5	42.0	46	36	589

Baumaße sind Ungefährmaße bei angezogener Überwurfmutter.

Sizes are approximate dimensions at tightened nut.

Las medidas son aproximadas con la tuerca de unión apretada.

Nach dem Anschweißen die in der Montageanleitung angegebenen Stellen nochmals mit der ASW Fettpaste schmieren (Klemmring, Gewinde der Mutter).

After welding, coat the parts indicated in the assembly instructions with ASW grease (clamping ring, thread of nut).

Luego de soldar, aplique nuevamente la grasa ASW en las partes indicadas en las instrucciones de montaje (anillo de apriete NC, roscas de tuercas).

D1=Rohr außen-Ø
M1=metrisches Anschlußgewinde

D1=tube outside diameter
M1=metric connecting thread

D1=Ø exterior del tubo
M1=rosca métrica conexión

Einschweiß-Schottverschraubungen
Weld-in bulkhead fittings
Racores de paso de mamparo para soldar

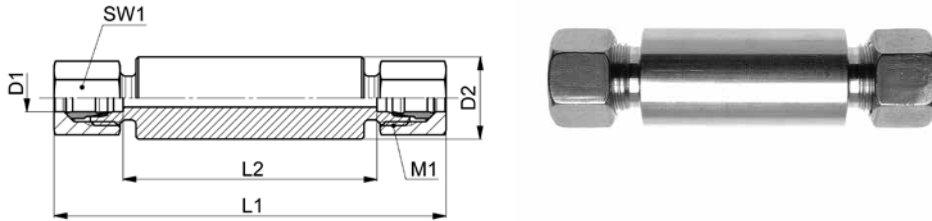

NC-ESV-..L/S

Type -D1	Mat.-Nr.	PN	M1	D2	L1	L2	SW1	g/Stk
NC-ESV-06L	718.1452.060.20	400	12x1.5	18.0	88.0	56.0	14	127
NC-ESV-08L	718.1452.080.20	400	14x1.5	20.0	88.0	56.0	17	155
NC-ESV-10L	718.1452.100.20	250	16x1.5	22.0	92.0	58.0	19	184
NC-ESV-12L	718.1452.120.20	250	18x1.5	25.0	91.0	58.0	22	236
NC-ESV-15L	718.1452.150.20	250	22x1.5	28.0	104.0	70.0	27	360
NC-ESV-18L	718.1452.180.20	160	26x1.5	32.0	103.0	69.0	32	480
NC-ESV-22L	718.1452.220.20	160	30x2.0	36.0	112.0	73.0	36	590
NC-ESV-06S	718.1452.060.30	500	14x1.5	20.0	92.0	60.0	17	177
NC-ESV-08S	718.1452.080.30	500	16x1.5	22.0	92.0	60.0	19	210
NC-ESV-10S	718.1452.100.30	400	18x1.5	25.0	96.0	59.0	22	272
NC-ESV-12S	718.1452.120.30	400	20x1.5	28.0	97.0	59.0	24	333
NC-ESV-14S	718.1452.140.30	300	22x1.5	30.0	113.0	72.0	27	454
NC-ESV-16S	718.1452.160.30	200	24x1.5	35.0	114.0	71.0	30	590
NC-ESV-20S	718.1452.200.30	200	30x2.0	38.0	121.0	71.0	36	748
NC-ESV-25S	718.1452.250.30	100	36x2.0	45.0	126.0	72.0	46	1180

Baumaße sind Ungefährmaße bei angezogener Überwurfmutter.

Sizes are approximate dimensions at tightened nut.

Las medidas son aproximadas con la tuerca de unión apretada.

Nach dem Anschweißen die in der Montageanleitung angegebenen Stellen nochmals mit der ASW Fettpaste schmieren (Klemmring, Gewinde der Mutter).

After welding, coat the parts indicated in the assembly instructions with ASW grease (clamping ring, thread of nut).

Luego de soldar, aplique nuevamente la grasa ASW en las partes indicadas en las instrucciones de montaje (anillo de apriete NC, roscas de tuercas).

D1=Rohr außen-Ø
M1=metrisches Anschlußgewinde

D1=tube outside diameter
M1=metric connecting thread

D1=Ø exterior del tubo
M1=rosca métrica conexión

NC-Überwurfmuttern

innen versilbert

NC nuts

silver-plated inside

Tuercas de unión

interior plateado

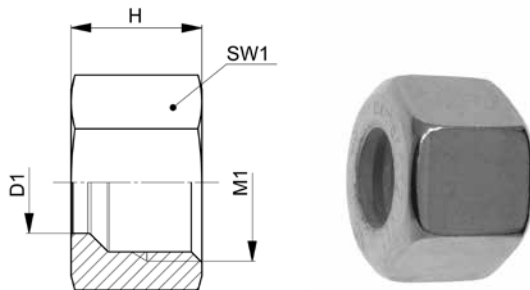

NC-UEM-..L/S

Type-D1	Mat.-Nr.	PN	PN DVGW	M1	H	SW1	g/Stk
M1=metrisches Gewinde (zylindrisch)	M1=metric thread (parallel)				M1=rosca métrica (cilindrica)		
NC-UEM-06L	716.0201.060.20	400	250	12x1.5	14.5	14	10
NC-UEM-08L	716.0201.080.20	400	250	14x1.5	14.5	17	15
NC-UEM-10L	716.0201.100.20	250	250	16x1.5	15.5	19	19
NC-UEM-12L	716.0201.120.20	250	250	18x1.5	15.5	22	25
NC-UEM-15L	716.0201.150.20	250	250	22x1.5	17.0	27	41
NC-UEM-18L	716.0201.180.20	160	250	26x1.5	18.0	32	63
NC-UEM-22L	716.0201.220.20	160	160	30x2.0	20.0	36	83
NC-UEM-06S	716.0201.060.30	500	250	14x1.5	16.5	17	16
NC-UEM-08S	716.0201.080.30	500	250	16x1.5	16.5	19	19
NC-UEM-10S	716.0201.100.30	400	250	18x1.5	17.5	22	29
NC-UEM-12S	716.0201.120.30	400	250	20x1.5	17.5	24	34
NC-UEM-14S	716.0201.140.30	300	250	22x1.5	20.5	27	50
NC-UEM-16S	716.0201.160.30	200	250	24x1.5	20.5	30	64
NC-UEM-20S	716.0201.200.30	200	250	30x2.0	24.0	36	103
NC-UEM-25S	716.0201.250.30	100	250	36x2.0	27.0	46	212

D1=Rohr außen-Ø
M1=metrisches Anschlußgewinde

D1=tube outside diameter
M1=metric connecting thread

D1=Ø exterior del tubo
M1=rosca métrica conexión

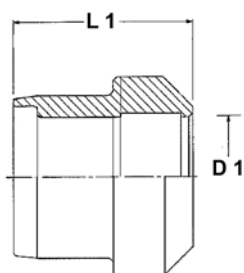
NC-Klemmringe
NC clamping rings
Anillos de apriete NC

NC-R..L/S

Type -D1	Mat.-Nr.	PN	L1	g/Stk
NC-R-06L/S	716.0010.060.13	400	9.0	2
NC-R-08L/S	716.0010.080.13	400	9.0	3
NC-R-10L/S	716.0010.100.13	250	10.0	3
NC-R-12L/S	716.0010.120.13	250	10.1	4
NC-R-15L	716.0010.150.20	250	10.0	3
NC-R-18L	716.0010.180.20	160	10.4	6
NC-R-22L	716.0010.220.20	160	12.6	9
NC-R-14S	716.0010.140.30	300	10.1	6
NC-R-16S	716.0010.160.30	200	10.6	5
NC-R-20S	716.0010.200.30	200	12.6	11
NC-R-25S	716.0010.250.30	100	12.6	14

**Bördel-Rohr-
verschraubungen**

**Flare tube
fittings**

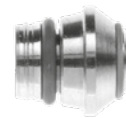
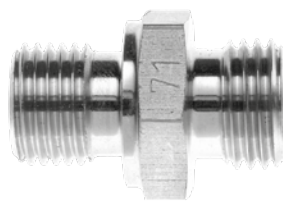
**Racores
rebordeados**



Seite/Page/Página

30.5
 Bördel-Rohrverschraubungen
 Flare tube fittings
 Acoplamientos de abocardar



BO-A..L/S

30.6
 Bördel-Zwischenringe
 Flare adaptors
 Anillos intermedios rebordeados



BO-ZR..L/S

30.7
 Bördel-Druckringe
 Flare sleeves
 Anillos de presión rebordeados



BO-DR..L/S

30.8
 Bördel-Muttern
 Flare nuts
 Tuercas rebordeadas



BO-M..L/S

Technische Information

Technical information

Información técnica

Bördel-Rohrverschraubungen

Flare tube fittings

Racores rebordeado

Eigenschaften, Besonderheiten

- Verschraubungsstutzen nach ISO 8434-1
- Zwischenring, Druckring und Mutter nach DIN 3949
- Baureihen L und S
- korrosionsbeständig

Characteristics, specialities

- fitting body according ISO 8434-1
- flare adaptor, sleeve and nut according DIN 3949
- series L and S
- corrosion resistant

Características, particularidades

- racor según ISO 8434-1
- anillo intermedio, anillo de presión y tuerca según DIN 3949
- series L y S
- resistencia a la corrosión

Funktionsprinzip

Operating principle

Principio de funcionamiento

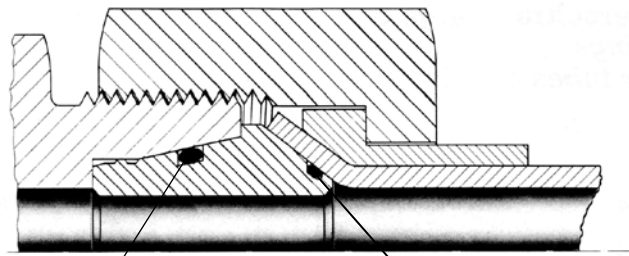

Abdichtung I: Verschraubungsstutzen – Zwischenring
Sealing I: Connector – flare adaptor
Cierre hermético I: Cuerpo - anillo intermedio rebordeado

Abdichtung II: Druckring – Rohr
Sealing II: Flare sleeve – tube
Cierre hermético II: Anillo de presión rebordeado – tubo

Das zentrale Bauelement – der Zwischenring – bildet den Übergang vom 24°-Konus des Verschraubungsstutzens zum 37°-Bördelanschluss. O-Ringe garantieren jederzeit eine sichere Abdichtung zum Stutzenkonus sowie zum Bördelanschluss, auch bei Druckwechselbelastungen.

Beim Anzug der Überwurfmutter wird über den Druckring und die Rohrschulter der Zwischenring in den Verschraubungskonus gedrückt. Durch eine leichte Verformung ist der Zwischenring dauerhaft mit dem Verschraubungsstutzen verbunden. Wenn die Stirnfläche des Verschraubungsstutzens am Bund des Zwischenrings anliegt, ist kein weiterer Vorschub möglich. Ein schädliches Aufweiten des Verschraubungsstutzens wird vermieden.

Die untrennbare Verbindung von Zwischenring und Verschraubungsstutzen bedeutet für den Monteur eine entscheidende Arbeitshilfe bei der Wiederholmontage. Die Verschraubung lässt sich beliebig oft lösen und wieder montieren. Der Druckring bewirkt eine sichere und kerbfreie Rohreinspannung.

Hohe Feindichtigkeit

- Elastomere an beiden Dichtstellen
- verbesserter Formschluss zwischen Zwischenring und Verschraubungsstutzen
- reduzierte Flächenpressung zwischen Rohr und Druckring
- größere Bördeltulpe und adaptierter Druckring garantieren sichere Rohrhalterung und hohe Ausreißfestigkeit
- keine Gefahr des Ausreißens bei Unteranzug

The main component – flare adaptor – effects the transition from the 24° taper of the connector to the 37° flare connection. O-rings assure sealing at the connectors taper and the flare connection. Thus a high degree of sealing efficiency is ensured, even under alternating pressure load.

When the nut is tightened, the flare adaptor is pressed into the cone of the fitting by the flare sleeve and the shoulder of the tube. Due to a slight deformation, the flare adaptor is permanently attached to the fitting. When the face surface of the fitting makes contact with the collar of the flare adaptor, no further insertion is possible. This prevents damaging expansion of the fitting body.

After tightening, because of a light deformation, the flare adaptor is captivated in the connector – a great help to the operator during reassembly. The fitting can be dismantled and reassembled as often as necessary. The flare sleeve provides for safe and notch-free tube clamping and high fatigue strength under bending load.

High degree of fine sealing efficiency

- elastomer at both sealing points
- improved form-fit between the flare adaptor and connector
- reduced surface pressure between tube and flare sleeve
- larger flange and adapted flare sleeve guarantee safe tube connection and high tensile strength
- no risk of disconnection when tightened insufficiently

El anillo intermedio como elemento central del conjunto constituye la transición del cono de 24° del cuerpo a la conexión rebordeada de 37°. El cierre hermético entre el cono del cuerpo y la conexión rebordeada se realiza mediante juntas tóricas. De esta forma se garantiza también una estanquidad alta con cargas de presión alternativas.

Al apretar la tuerca de unión, el anillo intermedio es encajado en el cono del racor por empuje del anillo de presión y del reborde del tubo. Por efecto de una ligera deformación, el anillo intermedio queda unido de forma permanente al racor. Cuando la superficie frontal del racor se apoya contra el collar del anillo intermedio, se impide todo avance posterior. De este modo se evita un ensanche excesivo del racor, que puede ser perjudicial.

Después de apretarlo, el anillo intermedio queda firmemente unido al racor. Para el montador representa una ayuda importante en caso de tener que repetir el montaje. El racor puede desmontarse y montarse las veces que sea necesario. El anillo de presión favorece el encaje seguro, sin entalladuras, del tubo y garantiza una resistencia alta y prolongada a la flexión.

Estanquidad fina

- elastómero en ambos puntos de cierre
- unión positiva mejorada entre el anillo y el cuerpo
- reducción de la presión entre las superficies del tubo y el anillo de presión
- reborde más grande y anillo de presión adaptado garantizan un soporte seguro des tubos y una alta resistencia al arranque
- no hay peligro de arranque por falta de apriete

Technische Information

Bördel-Rohrverschraubungen (cont.)

Technical information

Flare tube fittings (cont.)

Información técnica

Racores rebordeado (cont.)

Werkstoff

Edelstahl 1.4571
Legierung X 6 CrNiMoTi 17 12 2
≈ AISI 316 Ti

Material

Stainless steel 1.4571
alloy X 6 CrNiMoTi 17 12 2
≈ AISI 316 Ti

Material

Acero inoxidable 1.4571
aleación X 6 CrNiMoTi 17 12 2
≈ AISI 316 Ti

Nenndruck PN

bis 630 bar

Pressure nominal PN

up to 630 bar

Presión nominal PN

hasta 630 bar

Druckbereiche für Bördel-Rohrverschraubungen

Baureihe	Rohr	Nenndruck
L: leicht	6 - 10 mm	PN 500 (bar)
	12 - 18 mm	PN 400 (bar)
	22 - 42 mm	PN 250 (bar)
S: schwer	6 - 16 mm	PN 630 (bar)
	20 - 38 mm	PN 400 (bar)

Pressure ranges for Flare tube fittings

Serie	Tube	Pressure nom.
L: light	6 - 10 mm	PN 500 (bar)
	12 - 18 mm	PN 400 (bar)
	22 - 42 mm	PN 250 (bar)
S: heavy	6 - 16 mm	PN 630 (bar)
	20 - 38 mm	PN 400 (bar)

Rangos de presión para Racores rebordeado

Serie	Tubo	Presión nom.
L: ligera	6 - 10 mm	PN 500 (bar)
	12 - 18 mm	PN 400 (bar)
	22 - 42 mm	PN 250 (bar)
S: pesada	6 - 16 mm	PN 630 (bar)
	20 - 38 mm	PN 400 (bar)

Druckauswertungsgrad in % des PN

Pressure coefficient in % of PN

Grado de valoración de presión en % de la PN

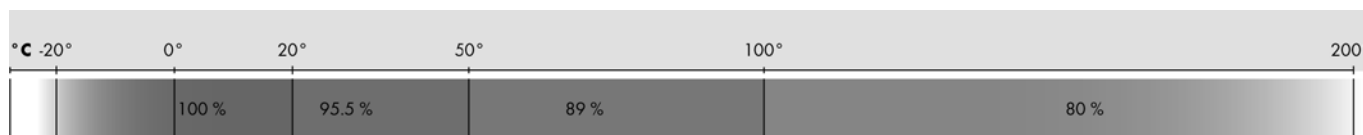

Temperaturbereich

-20°C bis +200°C

Temperature range

-20°C to +200°C

Intervalo de temperatura

de -20°C a +200°C

Helium-Leckrate

mind. 10⁻⁶ mbar • l/s bei fachgerechter Montage; siehe Kapitel a für Montageanleitung.

Helium leak rate

10⁻⁶ mbar • l/s min. when professionally assembled; see chapter a for installation instructions.

Tasa de fuga de helio

mín. 10⁻⁶ mbar • l/s con montaje correcto; para las instrucciones de montaje, consulte el capítulo a.

Vakuum

bis 10⁻⁴ mbar, höhere Werte möglich

Vacuum

up to 10⁻⁴ mbar, higher values are possible

Vacío

hasta 10⁻⁴ mbar; posibilidad de valores superiores

Anzuschließende Rohre

Nahtlose, gezogene Präzisionsrohre aus Edelstahl (DIN EN 10216-5/EN ISO 1127, Toleranzkl. D4/T3) mit sauberer, glatter Oberfläche. Außendurchmesser innerhalb ± 0,1 mm. Weitere Materialien auf Anfrage.

Tubes to use

Seamless, cold-drawn, high precision stainless steel tubes (according to DIN EN 10216-5/EN ISO 1127 tolerance class D4/T3) with clean, smooth surface. Outer diameter within ± 0,1 mm. Other materials on request.

Tubos para conectar

Tubos de precisión estirados sin costuras, de acero inoxidable (DIN EN 10216-5/EN ISO 1127, clase de tolerancia D4/T4) con superficie lisa limpia. Diámetro exterior con tolerancia de ± 0,1 mm. Otros materiales bajo demanda.

Bördel-Rohrverschraubungen

Baugruppe

Flare tube fittings

Components

Acoplamiento de abocardar

Grupo

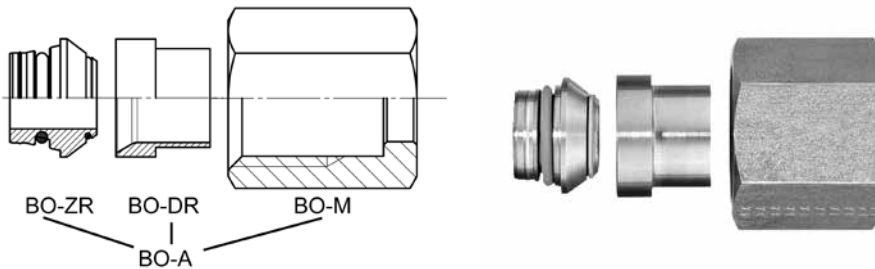

BO-A..L/S

Type -D1	Mat.-Nr.	PN	g/Stk
BO-A06L	708.0027.060.20	500	17
BO-A08L	708.0027.080.20	500	28
BO-A10L	708.0027.100.20	500	37
BO-A12L	708.0027.120.20	400	51
BO-A15L	708.0027.150.20	400	83
BO-A18L	708.0027.180.20	400	115
BO-A22L	708.0027.220.20	250	161
BO-A28L	708.0027.280.20	250	188
BO-A35L	708.0027.350.20	250	301
BO-A42L	708.0027.420.20	250	488
BO-A06S	708.0027.060.30	630	30
BO-A08S	708.0027.080.30	630	38
BO-A10S	708.0027.100.30	630	54
BO-A12S	708.0027.120.30	630	64
BO-A14S	708.0027.140.30	630	91
BO-A16S	708.0027.160.30	630	123
BO-A20S	708.0027.200.30	400	185
BO-A25S	708.0027.250.30	400	334
BO-A30S	708.0027.300.30	400	392
BO-A38S	708.0027.380.30	400	621

Dichtungsmaterial: FKM (andere Werkstoffe auf Anfrage)

Sealing material: FKM (other materials on request)

Material de junta tórica: FKM (otros materiales bajo demanda).

Bördel-Zwischenringe

mit O-Ring, gemäß DIN 3949

Flare adaptors

with O-ring, according to DIN 3949

Anillos intermedios rebordeados

con junta tórica, según DIN 3949

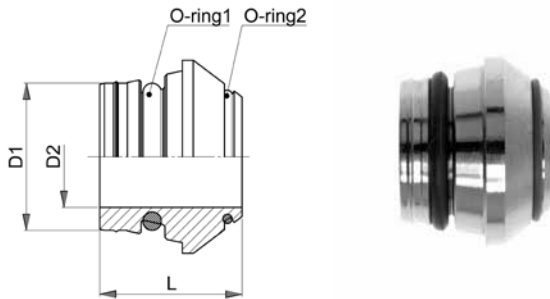

BO-ZR..L/S

Type-D1	Mat.-Nr.	PN	D2	L	O-Ring 1	O-Ring 2	g/Stk
BO-ZR06L/S	707.0028.060.13	630	3.0	11.5	4.0x1.5	4.4x0.8	3
BO-ZR08L/S	707.0028.080.13	630	5.0	12.0	6.0x1.5	6.0x0.8	4
BO-ZR10L/S	707.0028.100.13	630	6.0	12.5	7.5x1.5	7.5x0.8	6
BO-ZR12L/S	707.0028.120.13	630	8.0	12.5	9.0x1.5	9.5x0.8	8
BO-ZR15L	707.0028.150.20	400	11.0	12.5	12.0x2.0	12.5x0.8	10
BO-ZR18L	707.0028.180.20	400	14.0	13.0	15.0x2.0	15.0x1.0	12
BO-ZR22L	707.0028.220.20	250	17.0	14.2	20.0x2.0	18.0x1.0	20
BO-ZR28L	707.0028.280.20	250	23.0	14.7	26.0x2.0	23.0x1.0	26
BO-ZR35L	707.0028.350.20	250	28.0	18.5	32.0x2.5	30.0x1.0	58
BO-ZR42L	707.0028.420.20	250	35.0	20.5	38.0x2.5	37.0x1.0	77
BO-ZR14S	707.0028.140.30	630	9.0	14.5	12.0x2.0	11.0x1.0	13
BO-ZR16S	707.0028.160.30	630	11.0	15.0	12.0x2.0	12.5x1.0	15
BO-ZR20S	707.0028.200.30	400	14.0	18.5	16.3x2.4	16.0x1.0	27
BO-ZR25S	707.0028.250.30	400	19.0	20.0	20.3x2.4	20.0x1.0	38
BO-ZR30S	707.0028.300.30	400	23.0	22.0	25.3x2.4	25.0x1.0	57
BO-ZR38S	707.0028.380.30	400	30.0	26.0	33.3x2.4	32.0x1.8	92

O-Ringe aus FKM werden montiert geliefert.

Supplied with fitted o-rings made of FKM.

Las juntas tóricas de FKM se suministran montadas.

Bördel-Druckringe

gemäß DIN 3949

Flare sleeves

according to DIN 3949

Anillos de presión rebordeados

según DIN 3949

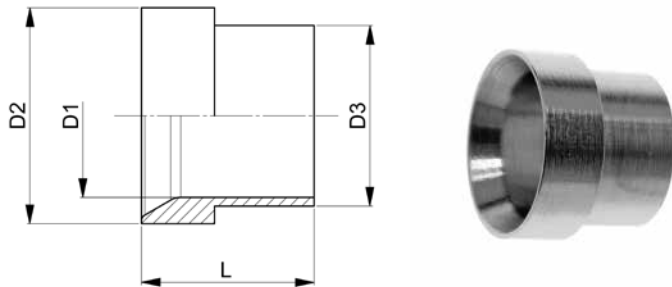

BO-DR..L/S

Type-D1	Mat.-Nr.	PN	D2	D3	L	g/Stk
BO-DR06L/S	706.0029.060.13	630	10.0	7.5	10.5	2
BO-DR08L/S	706.0029.080.13	630	12.0	9.5	11.0	3
BO-DR10L/S	706.0029.100.13	630	14.0	11.5	12.5	3
BO-DR12L/S	706.0029.120.13	630	16.0	13.5	13.0	4
BO-DR15L	706.0029.150.20	400	20.0	17.5	14.0	9
BO-DR18L	706.0029.180.20	400	24.0	21.0	14.5	14
BO-DR22L	706.0029.220.20	250	27.5	24.0	18.0	16
BO-DR28L	706.0029.280.20	250	33.5	30.0	17.0	19
BO-DR35L	706.0029.350.20	250	42.5	38.0	19.0	37
BO-DR42L	706.0029.420.20	250	50.0	45.0	21.0	49
BO-DR14S	706.0029.140.30	630	20.0	17.5	14.5	12
BO-DR16S	706.0029.160.30	630	24.0	18.5	17.0	12
BO-DR20S	706.0029.200.30	400	27.5	24.0	17.5	24
BO-DR25S	706.0029.250.30	400	32.5	28.5	20.0	30
BO-DR30S	706.0029.300.30	400	39.0	34.0	21.5	45
BO-DR38S	706.0029.380.30	400	48.5	42.0	26.5	76

Bördel-Muttern

gemäß DIN 3949

Flare nuts

according to DIN 3949

Tuercas rebordeadas

según DIN 3949

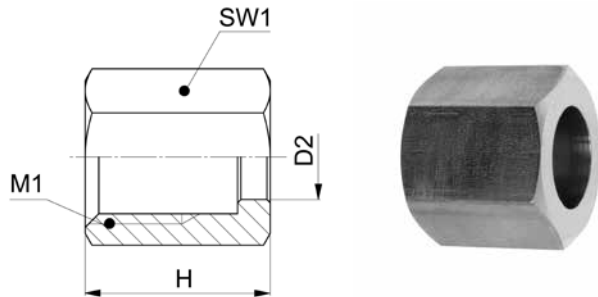

BO-M..L/S

Type-D1	Mat.-Nr.	PN	D2	M1	H	SW1	g/Stk
M1=metrisches Gewinde (zylindrisch)	M1=metric thread (parallel)				M1=rosca métrica (cilindrica)		
BO-M14S/15L	706.0064.150.13	630	17.5	22x1.5	23.0	27	57
BO-M20S/22L	706.0064.220.13	400	24.5	30x2.0	27.5	36	114
BO-M06L	706.0064.060.20	500	8.0	12x1.5	17.0	14	12
BO-M08L	706.0064.080.20	500	9.5	14x1.5	18.0	17	19
BO-M10L	706.0064.100.20	500	11.5	16x1.5	19.5	19	24
BO-M12L	706.0064.120.20	400	14.0	18x1.5	20.5	22	35
BO-M18L	706.0064.180.20	400	21.0	26x1.5	23.0	32	79
BO-M28L	706.0064.280.20	250	30.5	36x2.0	27.5	41	124
BO-M35L	706.0064.350.20	250	38.5	45x2.0	30.0	50	178
BO-M42L	706.0064.420.20	250	45.5	52x2.0	34.0	60	323
BO-M06S	706.0064.060.30	630	8.0	14x1.5	18.0	17	21
BO-M08S	706.0064.080.30	630	9.5	16x1.5	19.0	19	26
BO-M10S	706.0064.100.30	630	11.5	18x1.5	20.5	22	37
BO-M12S	706.0064.120.30	630	14.0	20x1.5	21.0	24	43
BO-M16S	706.0064.160.30	630	18.5	24x1.5	26.5	30	84
BO-M25S	706.0064.250.30	400	28.5	36x2.0	30.5	46	233
BO-M30S	706.0064.300.30	400	34.0	42x2.0	32.0	50	244
BO-M38S	706.0064.380.30	400	42.5	52x2.0	38.0	60	377

D1=Rohr außen-Ø

D1=tube outside diameter

D1=Ø exterior del tubo

Adapter

Adaptors

Adaptadores

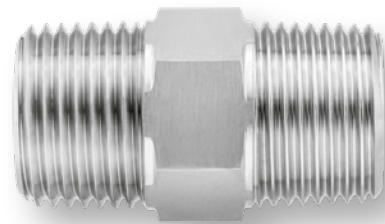

Adapter

Adaptors

Adaptadores

Seite/Page/Página

Seite/Page/Página

Seite/Page/Página

Gerade Adapter
Straight adaptors
Adaptadores rectos



Muffe lang
Threaded socket long
Manguito largo



Rohrkappe
Hexagonal cap
Remate de tubo



40.4

40.17

40.24

EA

AD C 50

AD HCP 50

Gerade Reduzieradapter
Straight reducing adaptors
Adaptadores de reducción rectos



Muffe kurz
Threaded socket short
Manguito corto



40.5

40.18

EAR

AD CS 50

Doppelnippel
Male threaded adaptor
Boquilla roscada doble



Sechskantmuffe
Hexagonal threaded socket
Manguito hexagonal



40.6-40.8

40.19

AD HN 50

AD HC 50

Rohrdoppelnippel
Tube double threaded nipple
Boquilla roscada doble de tubo



Sechskantmuffe reduziert
Hexagonal threaded socket reduced
Manguito hexagonal reducido



40.9

40.19

AD CN 50

AD HRC 50

Rohnippel
Tube nipple
Boquilla roscada de tubo



Hochdruckanschweissmuffe
High-pressure weld-on socket
Manguito de soldadura de alta presión



40.10

40.20

AD CNS 50

AD FCW 50 NPT

Rohranschweissnippel
Weld-on nipple
Boquilla para soldadura de tubo



Verschlusschraube
Locking screws
Tornillos de cierre



40.11

40.21-40.22

AD CNW 50

VSS

Übergangsnippel
Male adaptor
Racor reductor



Verschlusschraube
Screw plug
Tapón roscado



40.12-40.15

40.23

AD A 50

AD HP 50

Sechskantnippel
Hexagonal nipple
Boquilla roscada hexagonal



Verschlusschraube
Screw plug
Tapón roscado



40.16

40.24

ADH A 50

AD SP 50

Adapter	Adaptors	Adaptadores
Technische Information Adapter	Technical information Adaptors	Información técnica Adaptadores

Eigenschaften, Besonderheiten

- einfache Verbindungselemente mit Innen- und Außengewinden und Abschlusselementen
- zahlreiche Bauformen
- viele Kombinationsmöglichkeiten

Nenndruck PN

Siehe Produkttabellen (4-fache Sicherheit)

Werkstoff

Edelstahl 1.4571 (≈ AISI 316 Ti)

Gewinde

- G = Rohrgewinde BSP (zylindrisch) ISO 228
- R = Rohrgewinde (kegelig) EN 10226-1
- NPT = Rohrgewinde (kegelig) ANSI B 1.20.1

Characteristics, specialities

- simple connecting pieces with internal and external threads and end elements
- large number of design types
- many possible combinations

Pressure nominal PN

See product tables (safety factor 4)

Materials

Stainless steel 1.4571 (≈ AISI 316 Ti)

Threads

- G = BSP pipe thread (straight) ISO 228
- R = BSP pipe thread (tapered) EN 10226-1
- NPT = NPT pipe thread (tapered) ANSI B 1.20.1

Propiedades, particularidades

- elementos de unión sencillos con rosca interior exterior y elementos de remate
- numerosas formas constructivas
- numerosas posibilidades de combinación

Presión nominal PN

Véanse las tablas de productos (seguridad cuádruple)

Material

Acero inoxidable 1.4571 (≈ AISI 316 Ti)

Rosca

- G = Rosca de tubo BSP (cilíndrica) ISO 228
- R = Rosca de tubo (cónica) EN 10226-1
- NPT = Rosca de tubo (cónica) ANSI B 1.20.1

Gerade Adapter

mit 60° Konus, Abdichtung durch Dichtkante Form B nach DIN 3852-2

Straight adaptors

with 60° taper, sealing edge form B acc. DIN 3852-2

Adaptadores rectos

con cono de 60°, cierre hermético mediante borde de obturación forma B según DIN 3852-2

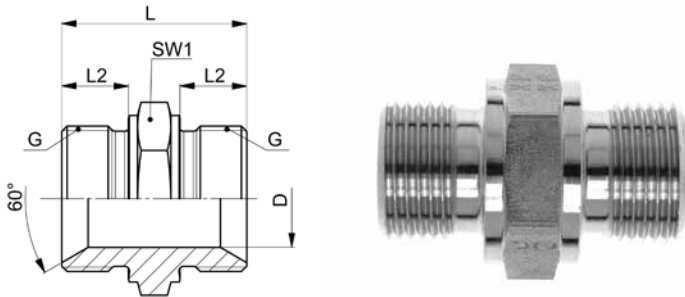

EA

Type-G	Mat.-Nr.	PN	D	G	L	L2	SW1	g/Stk
G=Rohrgewinde (zylindrisch)		G=BSP thread (parallel)			G=rosca de conexión (cilíndrica)			
EA-G 1.8/G 1.8	736.6052.090	400	4.0	1/8	23.0	8.0	14	14
EA-G 1.4/G 1.4	736.6052.091	400	6.0	1/4	29.0	10.0	19	32
EA-G 3.8/G 3.8	736.6052.092	400	8.0	3/8	35.0	12.0	22	56
EA-G 1.2/G 1.2	736.6052.093	400	10.0	1/2	41.0	14.0	27	100
EA-G 5.8/G 5.8	736.6052.094	400	12.0	5/8	43.0	16.0	30	115
EA-G 3.4/G 3.4	736.6052.095	400	15.0	3/4	46.0	16.0	32	151
EA-G 1.1/G 1.1	736.6052.096	400	19.0	1	52.0	18.0	41	250
EA-G 5.4/G 5.4	736.6052.097	200	30.0	1 1/4	58.0	20.0	50	371
EA-G 3.2/G 3.2	736.6052.098	200	32.0	1 1/2	61.0	22.0	55	511
EA-G 4.2/G 4.2	736.6052.099	100	39.0	2	61.0	22.0	70	771

Gerade Reduzieradapter

mit 60° Konus, Abdichtung durch Dichikante Form B nach DIN 3852-2

Straight reducing adaptors

with 60° taper, sealing edge form B acc. DIN 3852-2

Adaptadores de reducción rectos

con cono de 60°, cierre hermético mediante borde de obturación forma B según DIN 3852-2

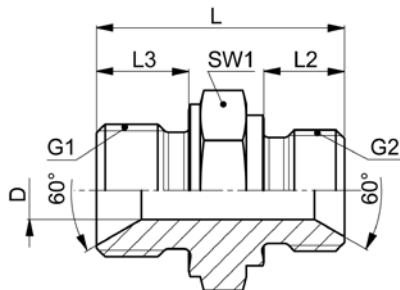

EAR

Type-G1 /G2	Mat.-Nr.	PN	D	G1	G2	L	L2	L3	SW1	g/Stk
G1=Rohrgewinde (zylindrisch)		G1=BSP thread (parallel)				G1=Rosca de conexión (cilíndrica)				
G2=Rohrgewinde (zylindrisch)		G2=BSP thread (parallel)				G2=Rosca de conexión (cilíndrica)				
EAR-G 1.4/G 1.8	736.6053.600	400	4.0	1/4	1/8	30.0	8.0	12.0	19	33
EAR-G 3.8/G 1.8	736.6053.601	400	4.0	3/8	1/8	30.5	8.0	12.0	22	47
EAR-G 3.8/G 1.4	736.6053.602	400	6.0	3/8	1/4	35.0	12.0	12.0	22	53
EAR-G 1.2/G 1.4	736.6053.603	400	6.0	1/2	1/4	39.0	12.0	14.0	27	88
EAR-G 1.2/G 3.8	736.6053.604	400	8.0	1/2	3/8	39.5	12.0	14.0	27	93
EAR-G 5.8/G 3.8	736.6053.605	400	8.0	5/8	3/8	40.5	12.0	16.0	30	110
EAR-G 5.8/G 1.2	736.6053.606	400	10.0	5/8	1/2	43.0	14.0	16.0	30	120
EAR-G 3.4/G 3.8	736.6053.607	400	8.0	3/4	3/8	42.5	12.0	16.0	32	142
EAR-G 3.4/G 1.2	736.6053.608	400	10.0	3/4	1/2	45.0	14.0	16.0	32	153
EAR-G 3.4/G 5.8	736.6053.609	400	12.0	3/4	5/8	45.5	16.0	16.0	32	152
EAR-G 1.1/G 3.8	736.6053.610	400	8.0	1	3/8	48.0	12.0	18.0	41	236
EAR-G 1.1/G 1.2	736.6053.611	400	10.0	1	1/2	54.0	14.0	18.0	41	233
EAR-G 1.1/G 3.4	736.6053.612	400	15.0	1	3/4	54.0	16.0	18.0	41	252
EAR-G 5.4/G 3.4	736.6053.613	200	15.0	1 1/4	3/4	56.0	16.0	20.0	50	404
EAR-G 5.4/G 1.1	736.6053.614	200	20.0	1 1/4	1	61.0	18.0	20.0	50	394
EAR-G 3.2/G 1.1	736.6053.615	200	20.0	1 1/2	1	63.0	18.0	22.0	55	557
EAR-G 3.2/G 5.4	736.6053.616	200	22.0	1 1/2	1 1/4	63.5	20.0	22.0	55	608
EAR-G 4.2/G 5.4	736.6053.617	100	22.0	2	1 1/4	65.5	20.0	24.0	70	547
EAR-G 4.2/G 3.2	736.6053.618	100	32.0	2	1 1/2	67.5	22.0	24.0	70	935

Doppelnippel G-R

60° Innenkonus / kegeliges Aussengewinde

Male threaded adaptor G-R

60° inner cone / tapered male thread

Boquilla roscada doble G-R

cono interior de 60° / rosca exterior cónica

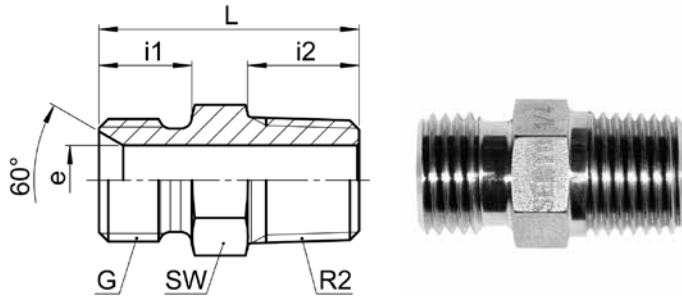

ADH HNIC 50

Type -G -R2	Mat.-Nr.	PN	SW	L	i1	i2	e	kg/100
G=Rohrgewinde (zylindrisch)		G=BSP thread (parallel)					G=rosca de conexión (cilíndrica)	
R2=Rohrgewinde (kegelig)		R2=BSP thread (tapered)						
ADH HNIC 50-1/8 -1/8	496.5210.042	400	10	22.0	9.0	8.0	4.0	0.760
ADH HNIC 50-1/4 -1/4	496.5210.104	400	14	28.0	11.0	12.0	7.5	1.120
ADH HNIC 50-3/8 -3/8	496.5210.166	400	17	30.0	11.5	12.0	10.0	3.280
ADH HNIC 50-1/2 -1/2	496.5210.228	400	22	34.0	12.0	14.0	12.0	5.480
ADH HNIC 50-3/4 -3/4	496.5210.292	160	27	38.0	13.0	16.0	17.0	9.000

Doppelnippel R
Male threaded adaptor R
Boquilla roscada doble R

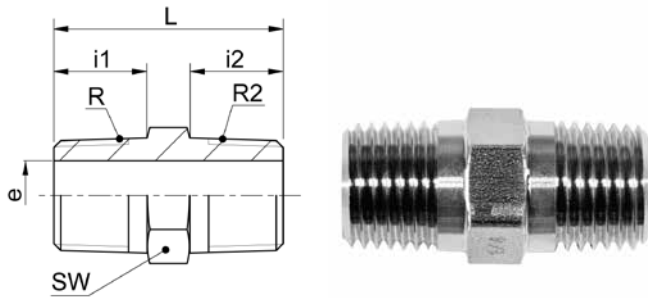

AD HN 50 R

Type -R-R2	Mat.-Nr.	PN	SW	L	i1	i2	e	kg/100
R=Rohrgewinde (kegelig)		R=BSP thread (tapered)						
R2=Rohrgewinde (kegelig)		R2=BSP thread (tapered)						
AD HN 50-1/8-1/8	TAD.5110.042	400	12	25.0	9.5	9.5	6.0	1.050
AD HN 50-1/8-1/4	TAD.5110.044	400	14	28.0	9.5	12.5	6.0	1.910
AD HN 50-1/8-3/8	TAD.5110.046	400	17	30.0	9.5	12.5	6.0	3.340
AD HN 50-1/8-1/2	TAD.5110.048	400	22	35.0	9.5	17.5	6.0	6.640
AD HN 50-1/4-1/4	TAD.5110.104	400	14	31.0	12.5	12.5	8.0	2.070
AD HN 50-1/4-3/8	TAD.5110.106	400	17	33.0	12.5	12.5	8.0	3.460
AD HN 50-1/4-1/2	TAD.5110.108	400	22	38.0	12.5	17.5	8.0	6.680
AD HN 50-3/8-3/8	TAD.5110.166	400	17	33.0	12.5	12.5	10.5	3.330
AD HN 50-3/8-1/2	TAD.5110.168	400	22	38.0	12.5	17.5	10.5	6.390
AD HN 50-1/2-1/2	TAD.5110.228	400	22	43.0	17.5	17.5	13.0	7.060
AD HN 50-1/2-3/4	TAD.5110.232	160	27	46.5	17.5	19.0	13.0	12.090
AD HN 50-1/2-1	TAD.5110.236	100	36	48.5	17.5	21.0	13.0	21.120
AD HN 50-3/4-3/4	TAD.5110.292	160	27	48.0	19.0	19.0	21.0	7.620
AD HN 50-3/4-1	TAD.5110.296	100	36	50.0	19.0	21.0	21.0	16.340
AD HN 50-1-1	TAD.5110.414	100	36	52.0	21.0	21.0	26.0	14.470

40

Doppelnippel R-NPT
Male threaded adaptor R-NPT
Boquilla roscada doble R-NPT

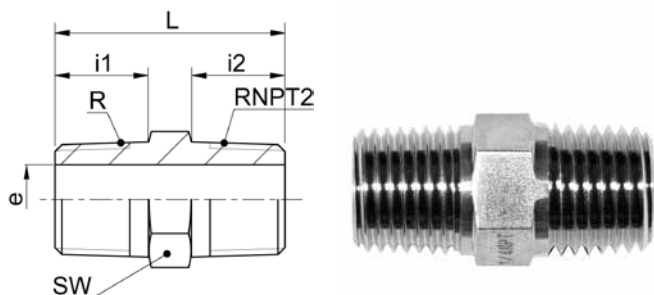

AD HN 50 R-NPT

Type -R -RNPT2	Mat.-Nr.	PN	SW	L	i1	i2	e	kg/100
R=Rohrgewinde (kegelig)		R=BSP thread (tapered)					R=rosca para tubos (cónica)	
RNPT2=NPT Gewinde		RNPT2=NPT thread					RNPT2=rosca de conexión cónica NPT	
AD HN 50-1/8-1/8 NPT	TAD.5114.042	400	12	25.0	9.5	9.5	6.0	1.060
AD HN 50-1/4-1/4 NPT	TAD.5114.104	400	14	31.0	12.5	12.5	8.0	2.060
AD HN 50-3/8-3/8 NPT	TAD.5114.166	400	17	33.0	12.5	12.5	10.5	3.260
AD HN 50-1/2-1/2 NPT	TAD.5114.228	400	22	43.0	17.5	17.5	13.0	6.850
AD HN 50-3/4-3/4 NPT	TAD.5114.292	160	27	48.0	19.0	19.0	21.0	7.370
AD HN 50-1-1 NPT	TAD.5114.414	100	36	52.0	21.0	21.0	26.0	13.760

Doppelnippel NPT
Male threaded adaptor NPT
Boquilla roscada doble NPT

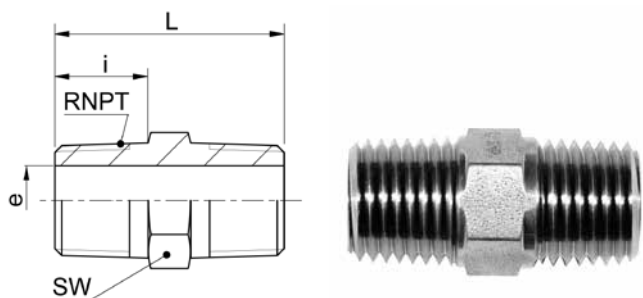

AD HN 50 NPT-NPT

Type -RNPT	Mat.-Nr.	PN	SW	L	i	e	kg/100
RNPT=NPT Gewinde		RNPT=NPT thread					RNPT=rosca de conexión cónica NPT
AD HN 50-1/8 NPT-1/8 NPT	TAD.5111.042	800	12	25.0	9.5	6.0	1.110
AD HN 50-1/4 NPT-1/4 NPT	TAD.5111.104	800	14	31.0	12.5	8.0	2.140
AD HN 50-3/8 NPT-3/8 NPT	TAD.5111.166	800	17	33.0	12.5	10.5	3.340
AD HN 50-1/2 NPT-1/2 NPT	TAD.5111.228	800	22	43.0	17.5	13.0	6.940
AD HN 50-3/4 NPT-3/4 NPT	TAD.5111.292	800	27	48.0	19.0	21.0	7.450
AD HN 50-1 NPT-1 NPT	TAD.5111.414	630	36	52.0	21.0	26.0	13.690

Rohrdoppelnippel R
Tube double threaded nipple R
Boquilla roscada doble de tubo R

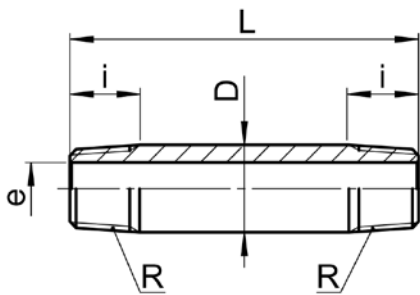

AD CN 50

Type -R xL	Mat.-Nr.	PN	L	D	i	e	kg/100
R=Rohrgewinde (kegelig)		R=BSP thread (tapered)				R=rosca para tubos (cónica)	
AD CN 50-1/8 x40	TAD.5150.021	400	40.0	10.0	8.0	6.0	1.400
AD CN 50-1/8 x60	TAD.5150.023	400	60.0	10.0	8.0	7.5	2.200
AD CN 50-1/4 x40	TAD.5150.042	400	40.0	14.0	9.0	9.0	2.400
AD CN 50-1/4 x60	TAD.5150.045	400	60.0	14.0	9.0	9.0	2.860
AD CN 50-1/4 x80	TAD.5150.049	400	80.0	14.0	9.0	9.0	5.700
AD CN 50-1/4 x100	TAD.5150.053	400	100.0	14.0	9.0	9.0	7.100
AD CN 50-1/4 x150	TAD.5150.058	400	150.0	14.0	9.0	9.0	8.000
AD CN 50-3/8 x60	TAD.5150.060	400	60.0	17.0	12.0	12.0	4.000
AD CN 50-1/2 x40	TAD.5150.082	400	40.0	21.0	13.0	16.0	3.600
AD CN 50-1/2 x60	TAD.5150.084	400	60.0	21.0	13.0	16.0	5.970
AD CN 50-1/2 x80	TAD.5150.086	400	80.0	21.0	13.0	16.0	8.100
AD CN 50-1/2 x100	TAD.5150.088	400	100.0	21.0	13.0	16.0	11.050
AD CN 50-1/2 x150	TAD.5150.093	400	150.0	21.0	13.0	16.0	15.900
AD CN 50-3/4 x80	TAD.5150.126	160	80.0	27.0	17.0	22.0	10.850
AD CN 50-3/4 x100	TAD.5150.128	160	100.0	27.0	17.0	20.0	12.800
AD CN 50-3/4 x150	TAD.5150.134	160	150.0	27.0	17.0	22.0	20.300
AD CN 50-1 x60	TAD.5150.162	100	60.0	34.0	17.0	28.0	11.600
AD CN 50-1 x80	TAD.5150.164	100	80.0	34.0	17.0	28.0	13.300
AD CN 50-1 x100	TAD.5150.166	100	100.0	34.0	17.0	28.0	14.900
AD CN 50-1 x150	TAD.5150.171	100	150.0	34.0	17.0	28.0	32.200
AD CN 50-1 x180	TAD.5150.174	100	180.0	34.0	17.0	28.0	38.600
AD CN 50-1 x200	TAD.5150.176	100	200.0	34.0	17.0	28.0	43.700

Rohrnippel G

Tube nipple G

Boquilla roscada de tubo G

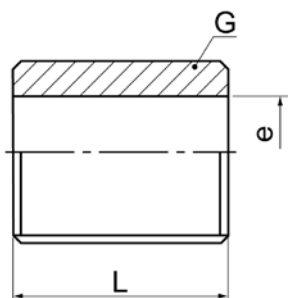

AD CNS 50

Type -G	Mat.-Nr.	PN	L	e	kg/100
G=Rohrgewinde (zylindrisch)		G=BSP thread (parallel)		G=rosca de conexión (cilíndrica)	
AD CNS 50-1/4	TAD.5180.104	400	18.0	9.0	0.600
AD CNS 50-3/8	TAD.5180.166	400	22.0	12.0	1.070
AD CNS 50-1/2	TAD.5180.228	400	25.0	16.0	1.440
AD CNS 50-3/4	TAD.5180.292	200	30.0	22.0	2.650

Rohranschweissnippel R
Weld-on nipple R
Boquilla para soldadura de tubo R

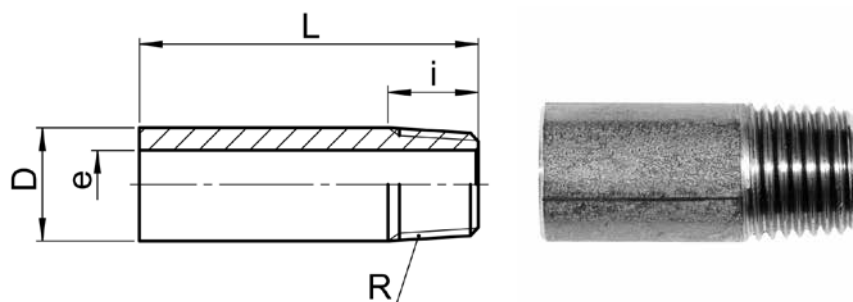

AD CNW 50

Type -R	Mat.-Nr.	PN	L	D	i	e	kg/100
R=Rohrgewinde (kegelig)		R=BSP thread (tapered)				R=rosca para tubos (cónica)	
AD CNW 50-1/8	TAD.5170.020	400	30.0	10.0	8.0	6.0	0.900
AD CNW 50-1/4	TAD.5170.040	400	30.0	13.5	9.0	9.0	1.100
AD CNW 50-3/8	TAD.5170.060	400	30.0	17.0	12.0	12.0	1.760
AD CNW 50-1/2	TAD.5170.080	400	35.0	21.0	13.0	16.5	3.600
AD CNW 50-3/4	TAD.5170.120	160	40.0	27.0	15.0	21.5	5.200
AD CNW 50-1	TAD.5170.160	100	40.0	34.0	17.0	28.0	5.250

40

Rohranschweissnippel NPT
Weld-on nipple NPT
Boquilla para soldadura de tubo NPT

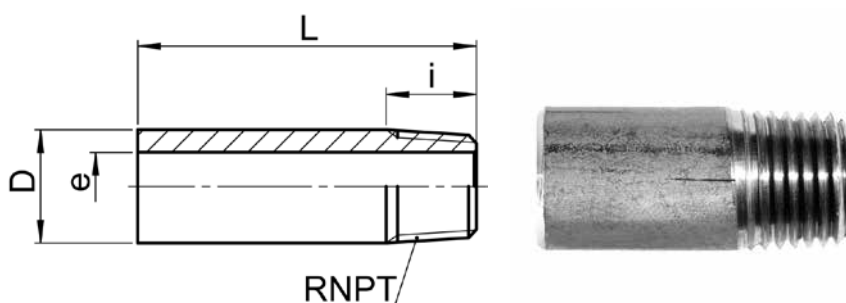

AD CNW 50 NPT

Type -RNPT	Mat.-Nr.	PN	L	D	i	e	kg/100
RNPT=NPT Gewinde		RNPT=NPT thread				RNPT=rosca de conexión cónica NPT	
AD CNW 50-1/8 NPT	TAD.5171.020	800	30.0	10.0	8.5	6.0	0.720
AD CNW 50-1/4 NPT	TAD.5171.040	800	30.0	13.5	12.5	8.8	1.140
AD CNW 50-3/8 NPT	TAD.5171.060	800	30.0	17.0	12.0	12.0	2.100
AD CNW 50-1/2 NPT	TAD.5171.080	800	35.0	21.0	13.0	16.5	2.400
AD CNW 50-3/4 NPT	TAD.5171.120	800	40.0	27.0	17.5	22.0	3.320
AD CNW 50-1 NPT	TAD.5171.160	630	40.0	33.5	21.0	27.5	5.010

Übergangsnippel G-R
Male adaptor G-R
Racor reductor G-R

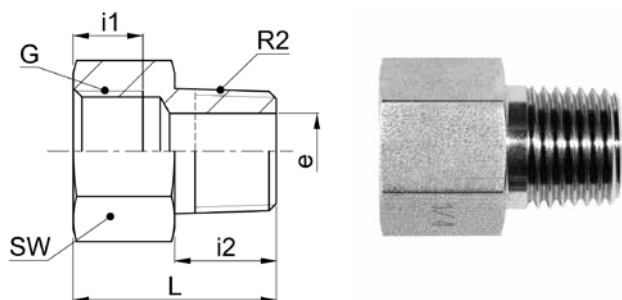

AD A 50 G-R

Type -G -R2	Mat.-Nr.	PN	SW	L	i1	i2	e	kg/100
G=Rohrgewinde (zylindrisch)		G=BSP thread (parallel)						
R2=Rohrgewinde (kegelig)		R2=BSP thread (tapered)						
AD A 50-1/8-1/8	TAD.5120.042	400	14	21.0	8.0	9.5	6.0	1.230
AD A 50-1/8-1/4	TAD.5130.044	400	14	18.5	8.0	12.0	8.7	1.140
AD A 50-1/8-3/8	TAD.5130.046	400	17	20.5	8.0	12.0	8.7	2.460
AD A 50-1/8-1/2	TAD.5130.048	400	22	25.5	8.0	14.0	8.7	5.510
AD A 50-1/4-1/8	TAD.5120.102	400	17	23.0	9.0	9.5	6.0	1.780
AD A 50-1/4-1/4	TAD.5120.104	400	17	26.0	9.0	12.5	8.0	2.200
AD A 50-1/4-3/8	TAD.5130.106	400	17	20.5	9.0	12.0	11.6	1.800
AD A 50-1/4-1/2	TAD.5130.108	400	22	25.5	9.0	14.0	11.6	4.700
AD A 50-1/4-3/4	TAD.5130.110	400	27	29.0	9.0	16.0	11.6	9.580
AD A 50-3/8-1/4	TAD.5120.164	400	22	28.0	9.5	12.5	8.0	3.590
AD A 50-3/8-3/8	TAD.5120.166	400	22	27.0	9.5	12.5	10.5	3.700
AD A 50-3/8-1/2	TAD.5130.168	400	22	25.5	9.5	14.0	15.2	3.940
AD A 50-3/8-3/4	TAD.5130.170	160	27	29.0	9.5	16.0	15.2	7.650
AD A 50-3/8-1	TAD.5130.172	100	36	31.0	9.5	18.0	15.2	16.640
AD A 50-1/2-1/4	TAD.5120.224	400	27	31.0	11.5	12.5	8.0	5.820
AD A 50-1/2-3/8	TAD.5120.226	400	27	30.0	11.5	12.5	10.5	5.790
AD A 50-1/2-1/2	TAD.5120.228	400	27	35.0	11.5	17.5	13.0	7.190
AD A 50-1/2-3/4	TAD.5130.232	160	27	29.0	11.5	16.0	19.0	6.080
AD A 50-1/2-1	TAD.5130.236	100	36	31.0	14.0	20.0	19.0	14.500
AD A 50-3/4-1/2	TAD.5120.288	200	32	39.0	14.0	17.5	13.0	9.670
AD A 50-3/4-3/4	TAD.5120.292	160	32	40.0	14.0	19.0	21.0	9.170
AD A 50-3/4-1	TAD.5130.296	100	36	31.0	14.0	18.0	24.5	10.490
AD A 50-1-1/2	TAD.5120.408	200	41	45.0	17.0	17.5	13.0	18.790
AD A 50-1-3/4	TAD.5120.412	160	41	45.0	17.0	19.0	21.0	17.130
AD A 50-1-1	TAD.5120.414	100	41	45.0	17.0	21.0	26.0	17.530

Übergangsnippel G-NPT
Male adaptor G-NPT
Racor reductor G-NPT

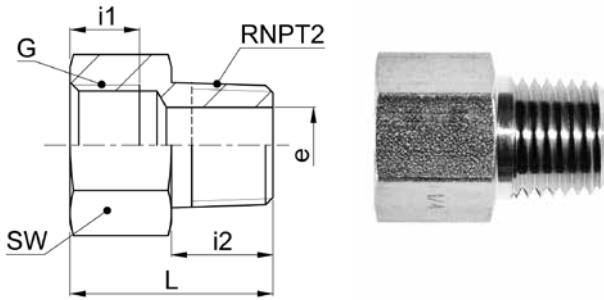

AD A 50 G-NPT

Type-G-RNPT2	Mat.-Nr.	PN	SW	L	i1	i2	e	kg/100
G=Rohrgewinde (zylindrisch)		G=BSP thread (parallel)						
RNPT2=NPT Gewinde		RNPT2=NPT thread						
G=rosca de conexión (cilíndrica)								
RNPT2=rosca de conexión cónica NPT								
AD A 50-1/8-1/8 NPT	TAD.5124.042	400	14	21.0	8.0	9.5	6.0	1.280
AD A 50-1/8-1/4 NPT	TAD.5134.044	400	14	18.5	8.0	12.5	8.7	1.220
AD A 50-1/8-3/8 NPT	TAD.5134.046	400	17	20.5	8.0	12.5	8.7	2.670
AD A 50-1/8-1/2 NPT	TAD.5134.048	400	22	25.5	8.0	17.5	8.7	5.900
AD A 50-1/4-1/8 NPT	TAD.5124.102	400	17	23.0	9.0	9.5	6.0	1.830
AD A 50-1/4-1/4 NPT	TAD.5124.104	400	17	26.0	9.0	12.5	8.0	2.280
AD A 50-1/4-3/8 NPT	TAD.5134.106	400	17	20.5	9.0	12.5	11.6	1.880
AD A 50-1/4-1/2 NPT	TAD.5134.108	400	22	25.5	9.0	17.5	11.6	5.050
AD A 50-1/4-3/4 NPT	TAD.5134.110	400	27	29.0	9.0	19.0	11.6	10.200
AD A 50-3/8-1/4 NPT	TAD.5124.164	400	22	28.0	9.5	12.5	8.0	3.670
AD A 50-3/8-3/8 NPT	TAD.5124.166	400	22	27.0	9.5	12.5	10.5	3.790
AD A 50-3/8-1/2 NPT	TAD.5134.168	400	22	25.5	9.5	17.5	15.2	3.490
AD A 50-1/2-1/4 NPT	TAD.5124.224	400	27	31.0	11.5	12.5	8.0	6.150
AD A 50-1/2-3/8 NPT	TAD.5124.226	400	27	30.0	11.5	12.5	10.5	6.130
AD A 50-1/2-1/2 NPT	TAD.5124.228	400	27	35.0	11.5	17.5	13.0	7.280
AD A 50-1/2-3/4 NPT	TAD.5134.232	400	27	29.0	11.5	19.0	19.0	6.170
AD A 50-3/4-1/2 NPT	TAD.5124.288	200	32	39.0	14.0	17.5	13.0	10.180
AD A 50-3/4-3/4 NPT	TAD.5124.292	200	32	40.0	14.0	19.0	21.0	9.650
AD A 50-3/4-1 NPT	TAD.5134.296	200	36	31.0	14.0	21.0	24.5	10.780
AD A 50-1-3/4 NPT	TAD.5124.412	200	41	45.0	17.0	19.0	21.0	18.180
AD A 50-1-1 NPT	TAD.5124.414	200	41	45.0	17.0	21.0	26.0	18.470

Übergangsnippel NPT-R
Male adaptor NPT-R
Racor reductor NPT-R

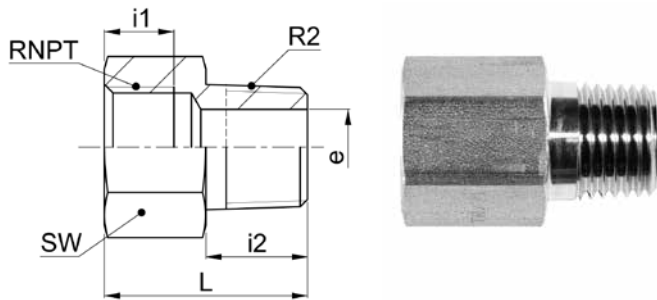

AD A 50 NPT-R

Type -RNPT -R2	Mat.-Nr.	PN	SW	L	i1	i2	e	kg/100
RNPT=NPT Gewinde		RNPT=NPT thread						
R2=Rohrgewinde (kegelig)		R2=BSP thread (tapered)						
AD A 50-1/8 NPT-1/8	TAD.5125.042	400	14	21.0	6.7	9.5	6.0	1.240
AD A 50-1/8 NPT-1/4	TAD.5135.044	400	14	18.5	6.7	12.5	8.4	1.150
AD A 50-1/4 NPT-1/4	TAD.5125.104	400	17	29.0	10.2	12.5	8.0	2.430
AD A 50-1/4 NPT-3/8	TAD.5135.106	400	17	20.5	10.2	12.5	10.8	1.870
AD A 50-1/4 NPT-1/2	TAD.5135.108	400	22	25.5	10.2	17.5	10.8	5.110
AD A 50-3/8 NPT-3/8	TAD.5125.166	400	22	29.0	10.3	12.5	10.5	4.050
AD A 50-1/2 NPT-1/2	TAD.5125.228	400	27	38.0	13.5	17.5	13.0	8.600
AD A 50-1/2 NPT-3/4	TAD.5135.232	160	27	29.0	13.5	19.0	17.7	6.830
AD A 50-3/4 NPT-3/4	TAD.5125.292	160	32	43.0	13.8	19.0	21.0	11.000
AD A 50-1 NPT-1	TAD.5125.414	160	36	45.0	17.4	21.0	26.0	12.830

Übergangsnippel NPT-NPT
Male adaptor NPT-NPT
Racor reductor NPT-NPT

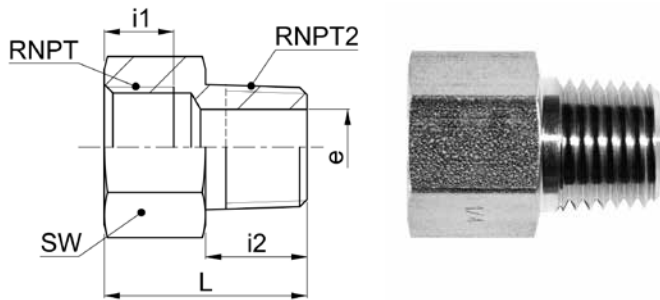

AD A 50 NPT-NPT

Type -RNPT -RNPT2	Mat.-Nr.	PN	SW	L	i1	i2	e	kg/100
RNPT=NPT Gewinde		RNPT=NPT thread						
RNPT2=NPT Gewinde		RNPT2=NPT thread						
AD A 50-1/8 NPT -1/4 NPT	TAD.5131.044	800	14	18.5	6.7	12.5	8.4	1.280
AD A 50-1/8 NPT -3/8 NPT	TAD.5131.046	800	17	20.5	6.7	12.5	8.4	2.660
AD A 50-1/4 NPT -1/8 NPT	TAD.5121.102	800	17	26.0	10.2	9.5	6.0	2.150
AD A 50-1/4 NPT -3/8 NPT	TAD.5131.106	800	17	20.5	10.2	12.5	10.8	2.070
AD A 50-1/4 NPT -1/2 NPT	TAD.5131.108	800	22	25.5	10.2	17.5	10.8	5.150
AD A 50-3/8 NPT -1/4 NPT	TAD.5121.164	800	22	30.0	10.3	12.5	8.0	3.920
AD A 50-3/8 NPT -1/2 NPT	TAD.5131.168	800	22	25.5	10.3	17.5	13.9	3.980
AD A 50-1/2 NPT -1/4 NPT	TAD.5121.224	800	27	35.0	13.5	12.5	8.0	7.510
AD A 50-1/2 NPT -3/8 NPT	TAD.5121.226	800	27	35.0	13.5	12.5	10.5	8.030
AD A 50-1/2 NPT -3/4 NPT	TAD.5131.232	800	27	29.0	13.5	19.0	17.7	6.820
AD A 50-1/2 NPT -1 NPT	TAD.5131.236	630	36	31.0	13.5	21.0	17.7	15.880
AD A 50-3/4 NPT -1/2 NPT	TAD.5121.288	800	32	43.0	13.8	17.5	13.0	12.030
AD A 50-3/4 NPT -1 NPT	TAD.5131.296	630	36	31.0	13.8	21.0	22.5	11.920
AD A 50-1 NPT -1/2 NPT	TAD.5121.408	630	36	48.0	17.4	17.5	13.0	14.540
AD A 50-1 NPT -3/4 NPT	TAD.5121.412	630	36	48.0	17.4	19.0	21.0	13.110

Sechskantnippel G

60° Innenkonus / Innengewinde

Hexagonal nipple G

60° inner cone / internal thread

Boquilla roscada hexagonal G

cono interior de 60° / rosca interior

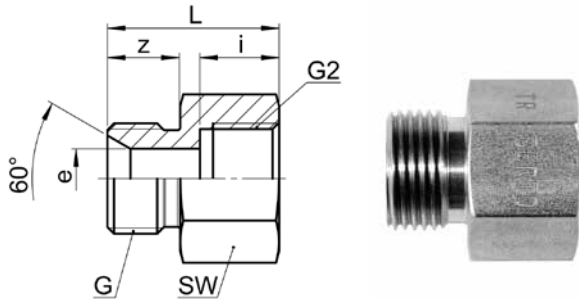

ADH A 50

Type-G-G2	Mat.-Nr.	PN	SW	L	i	z	e	kg/100
G=Rohrgewinde (zylindrisch)		G=BSP thread (parallel)					G=rosca de conexión (cilíndrica)	
G2=Rohrgewinde (zylindrisch)		G2=BSP thread (parallel)					G2=Rosca de conexión (cilíndrica)	
ADH A 50-3/8-3/8	496.5320.166	200	22	26.0	12.0	11.0	9.0	3.870
ADH A 50-1/2-1/2	496.5320.228	200	27	29.0	14.0	12.0	12.0	6.110

Muffe lang G
Threaded socket long G
Manguito largo G

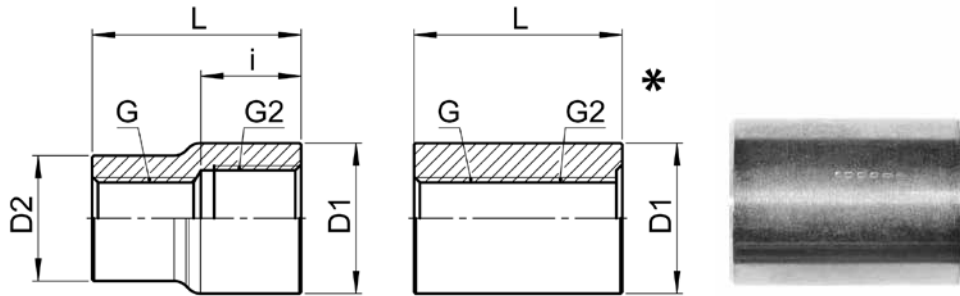

AD C 50

Type -G -G2	Mat.-Nr.	PN	L	D1	D2	i	kg/100
G=Rohrgewinde (zylindrisch)		G=BSP thread (parallel)			G=rosca de conexión (cilíndrica)		
G2=Rohrgewinde (zylindrisch)		G2=BSP thread (parallel)			G2=Rosca de conexión (cilíndrica)		
AD C 50-1/8-1/8 *	TAD.5140.042	400	17.0	14.0	0.0	0.0	1.150
AD C 50-1/8-1/4	TAD.5140.044	400	25.0	18.0	15.0	17.0	2.540
AD C 50-1/4-1/4	TAD.5140.104	400	25.0	18.0	0.0	0.0	2.150
AD C 50-1/4-3/8	TAD.5140.106	400	30.0	22.5	17.5	16.0	5.140
AD C 50-1/4-1/2	TAD.5140.108	400	37.0	28.0	18.0	17.0	8.600
AD C 50-3/8-3/8 *	TAD.5140.166	400	27.0	22.0	0.0	0.0	3.600
AD C 50-3/8-1/2	TAD.5140.168	400	34.0	28.0	22.0	20.0	7.660
AD C 50-1/2-1/2	TAD.5140.228	400	34.0	27.0	0.0	0.0	5.760
AD C 50-1/2-3/4	TAD.5140.232	200	39.0	33.0	27.0	18.0	13.860
AD C 50-3/4-3/4 *	TAD.5140.292	200	36.0	33.0	0.0	0.0	8.600
AD C 50-3/4-1	TAD.5140.296	200	45.0	40.0	33.0	21.0	26.340
AD C 50-3/4-1 1/4	TAD.5140.298	200	50.0	50.0	33.0	22.0	29.310
AD C 50-1-1 *	TAD.5140.414	200	43.0	40.0	0.0	0.0	15.250
AD C 50-1-1 1/4	TAD.5140.418	200	50.0	50.0	40.0	30.0	34.420

Muffe kurz G

Threaded socket short G

Manguito corto G

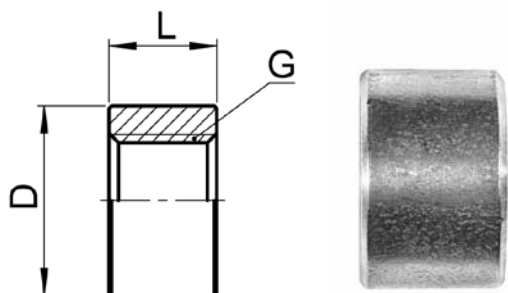

AD CS 50

Type -G	Mat.-Nr.	PN	L	D	kg/100
G=Rohrgewinde (zylindrisch)		G=BSP thread (parallel)		G=rosca de conexión (cilíndrica)	
AD CS 50-1/8	TAD.5200.042	400	8.0	14.0	0.500
AD CS 50-1/4	TAD.5200.104	400	11.0	17.0	0.900
AD CS 50-3/8	TAD.5200.166	400	12.0	22.0	1.550
AD CS 50-1/2	TAD.5200.228	400	15.0	27.0	2.600
AD CS 50-3/4	TAD.5200.292	200	17.0	32.0	3.670
AD CS 50-1	TAD.5200.414	200	19.0	40.0	6.100

Sechskantmuffe G
Hexagonal threaded socket G
Manguito hexagonal G

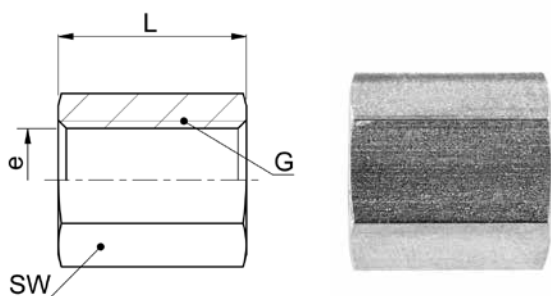

AD HC 50

Type -G	Mat.-Nr.	PN	SW	L	e	kg/100
G=Rohrgewinde (zylindrisch)		G=BSP thread (parallel)			G=rosca de conexión (cilíndrica)	
AD HC 50-1/8	TAD.5100.042	400	17	17.0	8.6	2.280
AD HC 50-1/4	TAD.5100.104	400	22	25.0	11.4	5.500
AD HC 50-3/8	TAD.5100.166	400	22	26.0	15.0	4.400
AD HC 50-1/2	TAD.5100.228	400	27	34.0	18.6	8.430
AD HC 50-3/4	TAD.5100.292	200	32	36.0	24.1	10.690
AD HC 50-1	TAD.5100.414	200	46	43.0	30.3	33.200

40

Sechskantmuffe G reduziert
Hexagonal threaded socket G reduced
Manguito hexagonal G reducido

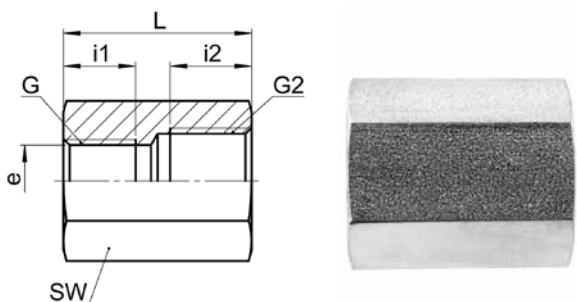

AD HRC 50

Type -G -G2	Mat.-Nr.	PN	SW	L	i1	i2	e	kg/100
G=Rohrgewinde (zylindrisch)		G=BSP thread (parallel)					G=rosca de conexión (cilíndrica)	
G2=Rohrgewinde (zylindrisch)		G2=BSP thread (parallel)					G2=Rosca de conexión (cilíndrica)	
AD HRC 50-1/8-1/4	TAD.5100.044	400	22	25.0	8.0	9.0	8.6	5.940
AD HRC 50-1/8-3/8	TAD.5100.046	400	22	30.0	8.0	9.5	8.6	6.500
AD HRC 50-1/8-1/2	TAD.5100.048	400	27	41.0	8.0	11.5	8.6	14.100
AD HRC 50-1/4-3/8	TAD.5100.106	400	22	29.0	9.0	9.5	11.4	5.750
AD HRC 50-1/4-1/2	TAD.5100.108	400	27	40.0	9.0	11.5	11.4	12.950
AD HRC 50-3/8-1/2	TAD.5100.168	400	27	38.0	9.5	11.5	15.0	10.060
AD HRC 50-1/2-3/4	TAD.5100.232	200	32	41.0	11.5	14.0	18.6	15.200
AD HRC 50-1/2-1	TAD.5100.236	200	46	51.0	11.5	17.0	18.6	48.710

Hochdruckanschweissmuffe NPT
High-pressure weld-on socket NPT
Manguito de soldadura de alta presión NPT

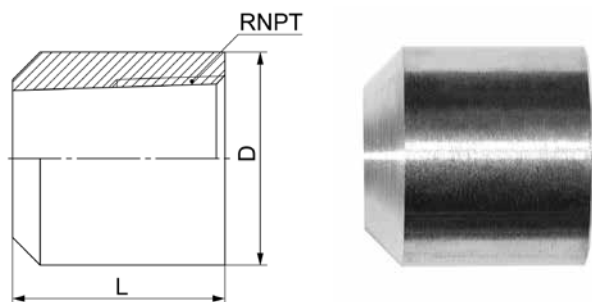

AD FCW 50 NPT

Type -RNPT	Mat.-Nr.	PN	L	D	kg/100
RNPT=NPT Gewinde	RNPT=NPT thread			RNPT=rosca de conexión cónica NPT	
AD FCW 50-1/8 NPT	TAD.5161.042	800	21.0	20.0	3.700
AD FCW 50-1/4 NPT	TAD.5161.104	800	25.0	25.0	6.900
AD FCW 50-3/8 NPT	TAD.5161.166	800	30.0	25.0	7.100
AD FCW 50-1/2 NPT	TAD.5161.228	800	30.0	32.0	11.600
AD FCW 50-1 NPT	TAD.5161.414	630	50.0	50.0	39.500

Verschlusschraube

mit Außensechskant und Bund nach DIN 910, Abdichtung durch Dichtring Form A

Locking screws

with external hexagon and shoulder acc. to DIN 910, sealing ring form A

Tornillos de cierre

con hexágono exterior y collar según DIN 910, cierre hermético mediante junta forma A

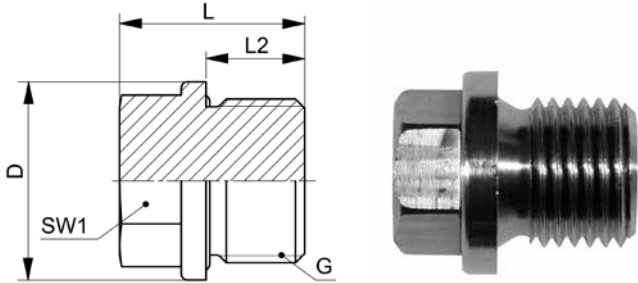

VSS-..R

Type-G	Mat.-Nr.	PN	G	D	L	L2	SW1	g/Stk
G=Rohrgewinde (zylindrisch)		G=BSP thread (parallel)			G=rosca de conexión (cilíndrica)			
VSS-R 1.8	706.0719.020	800	1/8	14.0	17.0	8.0	10	12
VSS-R 1.4	706.0719.040	800	1/4	18.0	21.0	12.0	13	26
VSS-R 3.8	706.0719.060	800	3/8	22.0	21.0	12.0	17	40
VSS-R 1.2	706.0719.080	800	1/2	26.0	26.5	14.0	19	70
VSS-R 3.4	706.0719.120	800	3/4	32.0	30.0	16.0	24	126
VSS-R 1.1	706.0719.160	630	1	39.0	32.0	16.0	27	199

Verschlusschraube NPT

mit Außensechskant

Locking screws NPT

with external hexagon

Tornillos de cierre NPT

con hexágono exterior

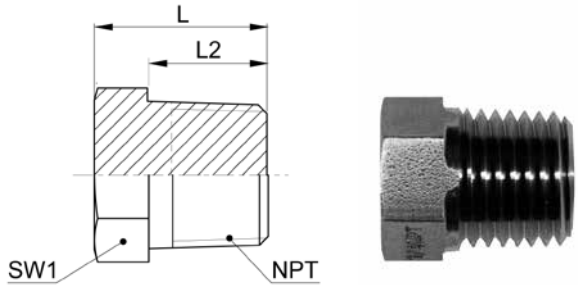

VSS-..NPT

Type -NPT	Mat.-Nr.	PN	L	L2	SW1	g/Stk
NPT=Einschraubgewinde NPT		NPT=tapered male adaptor thread NPT		NPT=rosca de conexión cónica NPT		
VSS-1.8 NPT	706.0720.020.30	800	15.5	9.5	12	10
VSS-1.4 NPT	706.0720.040.30	800	18.5	12.5	14	22
VSS-3.8 NPT	706.0720.060.30	800	20.5	12.5	17	38
VSS-1.2 NPT	706.0720.080.30	800	25.5	17.5	22	75
VSS-3.4 NPT	706.0720.120.30	800	29.0	19.0	27	134
VSS-1.1 NPT	706.0720.160.30	630	31.0	21.0	36	232

Verschlusschraube R

mit Aussen-6kt.

Screw plug R

with hex-nut

Tapón roscado R

con hexágono exterior

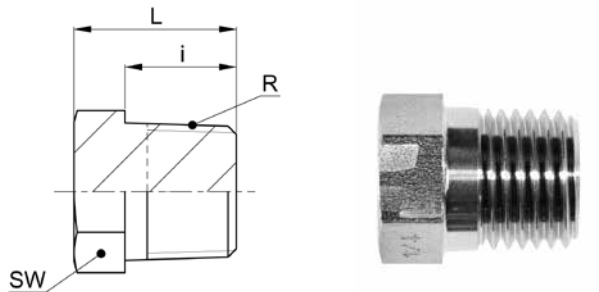

AD HP 50 R

Type-R	Mat.-Nr.	PN	SW	L	i	kg/100
R=Rohrgewinde (kegelig)		R=BSP thread (tapered)			R=rosca para tubos (cónica)	
AD HP 50-1/8	TAD.5020.020	400	12	12.5	8.0	1.020
AD HP 50-1/4	TAD.5020.040	400	14	17.5	12.0	1.900
AD HP 50-3/8	TAD.5020.060	400	17	18.0	12.0	3.290
AD HP 50-1/2	TAD.5020.080	400	22	21.0	14.0	6.550
AD HP 50-3/4	TAD.5020.120	160	27	24.0	16.0	11.680
AD HP 50-1	TAD.5020.160	100	36	28.0	18.0	20.540

Verschlusschraube R

mit Innen-6kt.

Screw plug R

locked with Allen key

Tapón roscado R

con hexágono interior

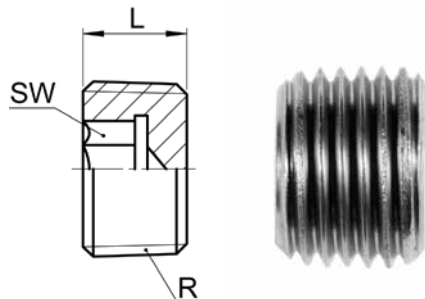

AD SP 50

Type -R	Mat.-Nr.	PN	SW	L	kg/100
R=Rohrgewinde (kegelig)		R=BSP thread (tapered)		R=rosca para tubos (cónica)	
AD SP 50-1/8	TAD.5010.020	400	5	8.0	0.340
AD SP 50-1/4	TAD.5010.040	400	7	10.0	0.740
AD SP 50-3/8	TAD.5010.060	400	8	10.0	1.250
AD SP 50-1/2	TAD.5010.080	400	10	10.0	1.940
AD SP 50-3/4	TAD.5010.110	160	12	12.0	3.800
AD SP 50-1	TAD.5010.160	160	17	12.0	5.760

Rohrkappe G

Hexagonal cap G

Remate de tubo G

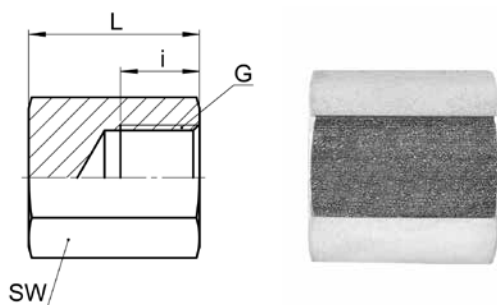

AD HCP 50

Type -G	Mat.-Nr.	PN	SW	L	i	kg/100
G=Rohrgewinde (zylindrisch)		G=BSP thread (parallel)		G=rosca de conexión (cilíndrica)		
AD HCP 50-1/8	TAD.5000.020	400	17	19.0	8.0	2.760
AD HCP 50-1/4	TAD.5000.040	400	22	24.0	9.0	5.940
AD HCP 50-3/8	TAD.5000.060	400	22	27.0	9.5	5.880
AD HCP 50-1/2	TAD.5000.080	400	27	37.0	11.5	12.700
AD HCP 50-3/4	TAD.5000.120	200	32	38.0	14.0	16.370
AD HCP 50-1	TAD.5000.160	200	46	44.0	17.0	43.200

**Kugelhähne und
Ventile**

**Ball valves and
Valves**

**Llaves esféricas y
Válvulas**

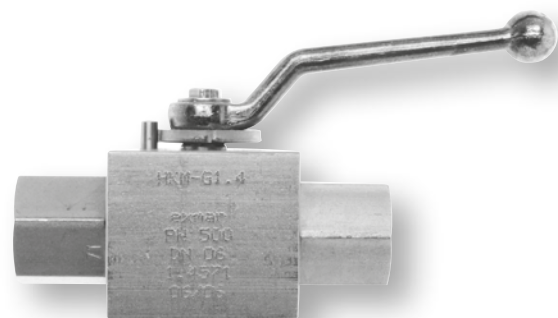

Seite/Page/Página

Niederdruck-Kugelhähne
Low pressure ball valves
Llaves esféricas de baja presión

50.5-50.13



NKM/NKS

Hochdruck-Kugelhähne
High pressure ball valves
Llaves esféricas de alta presión

50.14-50.21



HKM/HKS

Rückschlagventile
Non-return valves
Válvulas de retención

50.23-50.25



DRM

Rückschlagventile
Non-return valves
Válvulas de retención

50.26-50.27



DRV

Rückschlagventile m. Einschraubgewinde
Non-return valves w. male adaptor thread
Válvulas de retención con conexión de rosca

50.28-50.31



ERVZ/ERVV

NC-Rückschlagventile
NC Non-return valves
Válvulas de retención NC

50.32-50.34



NC-DRV/NC-ERVZ/NC-ERVV

Hochdruck-Absperrventile
High pressure needle valves
Válvulas de cierre de alta presión

50.35-50.45



AVD/AVI

Manometer-Ventile
Gauge valves
Válvulas manométricas

50.46-50.47



MV-R 16270/16271

Seite/Page/Página

Drosselventile
Throttle valves
Válvulas reguladoras

50.48-50.50



EFT 2257

Schnellverschluss-Kupplungen
Quick couplings
Acoplamientos de cierre rápido

50.51



EKM-EKS

Technische Informationen

Technical Information

Información Técnica

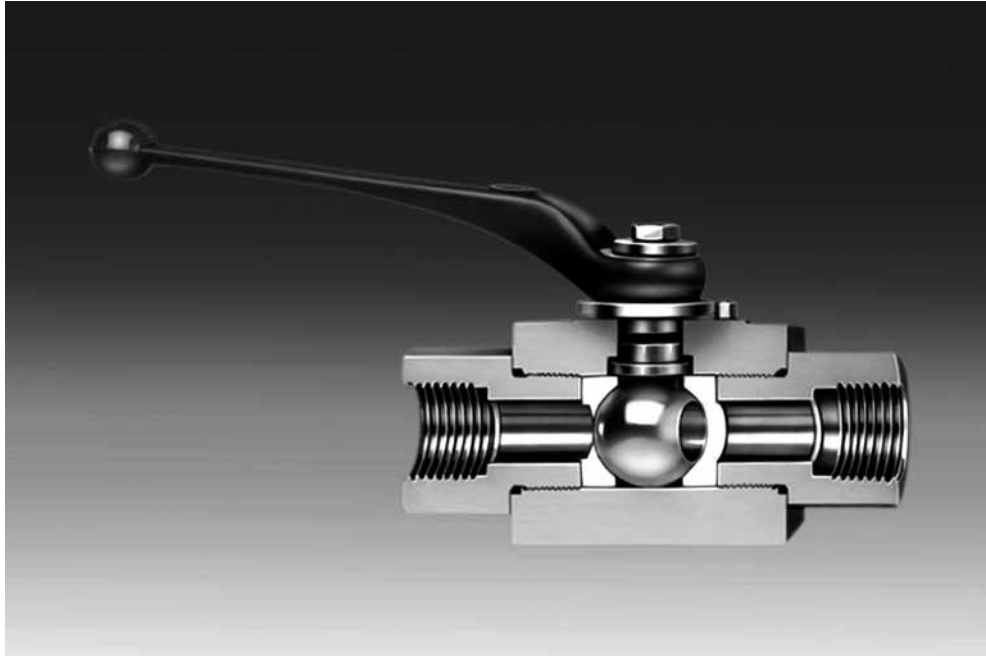

1. Werden nur aus rost- und säurebeständigen Edelstählen gefertigt.
2. Dadurch größte Einsatzmöglichkeit in allen Industriezweigen.
3. Durch Vollstromquerschnitte keine Druckverluste.
4. Leichte Schaltbarkeit auch unter hohem Druck.
5. Durch auswechselbare Dichtungen lange Lebensdauer.
6. Einzelprüfungen vor Verlassen des Werkes.

1. Made only from rust proof and acid resistant stainless steel.
2. For a wide range of applications in all industries.
3. No pressure drop due to full flow bore.
4. Easy operation, even under high pressure.
5. Long life due to replaceable seals.
6. Individual tests before leaving the works.

1. Fabricación exclusiva con aceros inoxidable-resistentes a la corrosión y a los ácidos.
2. En consecuencia, pueden usarse en todos los ramos industriales.
3. Las secciones transversales de caudal máximo evitan pérdidas de presión.
4. Manejo fácil también con presiones altas.
5. Larga vida útil gracias a juntas recambiables.
6. Controles individuales antes de salir de fábrica.

Zur Auswahl der richtigen Armatur werden folgende Mindestangaben benötigt:

- Betriebsdruck
- Betriebstemperatur
- Medium

Konstruktionsaufbau

Alle Körper der EXMAR Kugelhähne werden aus hochwertigem Edelstahl gefertigt. Die Kugel als drehbares Absperrelement ist "schwimmend" gelagert mit Vorspannung zwischen Dichtschalen aus POM oder aus anderen Werkstoffen.

Das Medium drückt in Fließrichtung bei geschlossener Stellung gegen die Kugel und presst diese gegen die druckabgewandte Dichtschale. Die Dauerdichtheit wird dadurch unterstützt.

Lagerung und Einbau

Die Kugelhähne sollen in Offenstellung mit Schutzkappen gelagert werden. Sie sollen auch in Offenstellung eingebaut werden und vor Betätigungen müssen die Leitungen durchgespült werden, damit Rückstände in den Leitungen die Dichtschalen nicht beschädigen.

Die Kugelhähne öffnen und schließen durch Drehung des Schaltgriffes um jeweils 90°. Zwischenstellungen bewirken eine nicht gewünschte Drosselung des Durchflusses. Der Kugelhahn soll daher stets geschlossen oder bis zum Anschlag geöffnet sein.

Werkzeugnisse

Auf Wunsch werden Werksbescheinigungen oder Werkzeugnisse nach DIN EN 10204 erstellt.

Allgemeine Hinweise

Die angegebenen Nenndrücke gelten für eine max. Betriebstemperatur bis zu +100°C für normale Bedingungen bei statischer Druckbelastung.

For orders or inquiries the following information is required:

- working pressure
- working temperature
- medium

Design Principle

All EXMAR ball valves are made of high quality stainless steel. The ball, as a rotatable close-off unit, is pretensioned and "floats" in a shell seal made from POM or other suitable material.

In the closed position the medium pressure acts against the ball in the flow direction, and presses it against the pressure free side of the shell seal. The continuous leak-free function is thereby enhanced.

Storage and Installation

The ball valves should be stored in the open position with dust caps fitted. They should also be installed in the open position, and, in order to prevent damage to the shell seals by residue in the piping system, the system should be flushed before operating the valves.

The ball valves open and close by turning the valve key through 90°. An inbetween position results in an undesirable flow restriction. A ball valve should therefore be either fully closed or opened to the stop.

Certification

On request a works certificate or release note can be issued according to DIN EN 10204.

General Information

The given nominal pressures are for normal conditions under static loading at operating temperatures of up to +100°C max.

Para elegir la válvula adecuada se requieren como mínimo los siguientes datos:

- presión de servicio
- temperatura de servicio
- medio

Diseño constructivo

Todos los cuerpos de las llaves esféricas EXMAR están fabricados de alta calidad en acero inoxidable. La bola como elemento de cierre giratorio tiene apoyo "flotante" pretensado entre los asientos de POM u otros materiales.

El medio presiona contra la bola cerrada en la dirección de flujo y la empuja contra el asiento alejado de la presión. De esta forma se prolonga la estanquidad.

Almacenaje y montaje

Las llaves esféricas deben almacenarse en posición abierta, protegidas con caperuzas. Han de montarse asimismo en posición abierta y, antes de accionarlas, hay que limpiar las tuberías para que los restos que pueda haber en las mismas no dañen los asientos.

Las llaves esféricas se abren y cierran girando la palanca 90°, respectivamente. En posiciones intermedias se provoca una reducción no deseable del flujo. Por esta razón, la llave esférica ha de estar siempre completamente cerrada o abierta.

Certificados de material

Bajo demanda se entregarán certificados de fábrica o de material según DIN EN 10204.

Advertencias generales

Las presiones nominales señaladas valen solamente para una temperatura de servicio máxima de hasta +100°C en condiciones de uso normales con carga de presión estática.

Technische Informationen

Technical Information

Información Técnica

**Niederdruck-Kugelhahn
PN 130/100**

**Low Pressure Ball Valve
PN 130/100**

**Llave esférica de baja presión
PN 130/100**

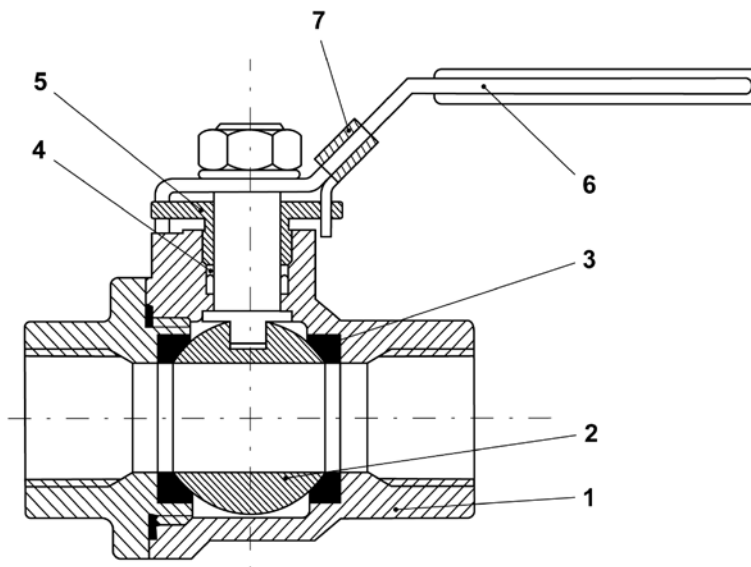

	Bauteil Part Componente	Werkstoff Material Material
1	Gehäuse Body Carcasa	Edelstahl 1.4408 / AISI 316 Stainless steel 1.4408 / AISI 316 Acero inoxidable 1.4408 / AISI 316
2	Kugel Ball Bola	Edelstahl 1.4408 / AISI 316 Stainless steel 1.4408 / AISI 316 Acero inoxidable 1.4408 / AISI 316
3	Dichtung Sealing Junta	PTFE + 15 % GF* PTFE + 15 % GF* PTFE + 15 % GF*
4	Spindeldichtung Stem sealing Husillo de junta	PTFE PTFE PTFE
5	Stopfbuchse Gland Prensaestopas	Edelstahl 1.4301 / AISI 304 Stainless steel 1.4301 / AISI 304 Acero inoxidable 1.4301 / AISI 304
6	Hebel Handle Palanca	Edelstahl 1.4301 / AISI 304 Stainless steel 1.4301 / AISI 304 Acero inoxidable 1.4301 / AISI 304
7	Abschliessvorrichtung Locking device Posicionador da cerrar	Edelstahl 1.4301 / AISI 304 Stainless steel 1.4301 / AISI 304 Acero inoxidable 1.4301 / AISI 304

2-teilig

Voller Durchgang
Innengewinde DIN ISO 228/1
Druck: 130 bar / 1/4" bis 1"
Druck: 100 bar / 1/4" bis 2"
Sicherheitsfaktor: 1.5-fach
Dichtung: PTFE +15 % GF*
Temperatur: -50°C bis +180°C

2-parts

Full bore
Female thread DIN ISO 228/1
Pressure: 130 bar (2000 psi) / 1/4" to 1"
Pressure: 100 bar (1500 psi) / 1/4" to 2"
Safety factor: 1.5 times
Sealing: PTFE +15 % GF*
Temperature: -50°C to +180°C

2 piezas

Paso total
Rosca interior DIN ISO 228/1
Presión: 130 bar / 1/4" a 1"
Presión: 100 bar / 1/4" a 2"
Factor de seguridad: 1.5 veces
Junta: PTFE + 15 % GF*
Temperatura: -50°C a +180°C

* glasfaserverstärkt

* fiber-glass reinforced

* refuerzo de fibra de vidrio

Druck-Temperatur-Diagramm

Niederdruck-Kugelhahn PN 130

Pressure-Temperature-Diagram

Low pressure ball valve PN 130

Diagrama de presión y temperatura

Llave esférica de baja presión PN 130

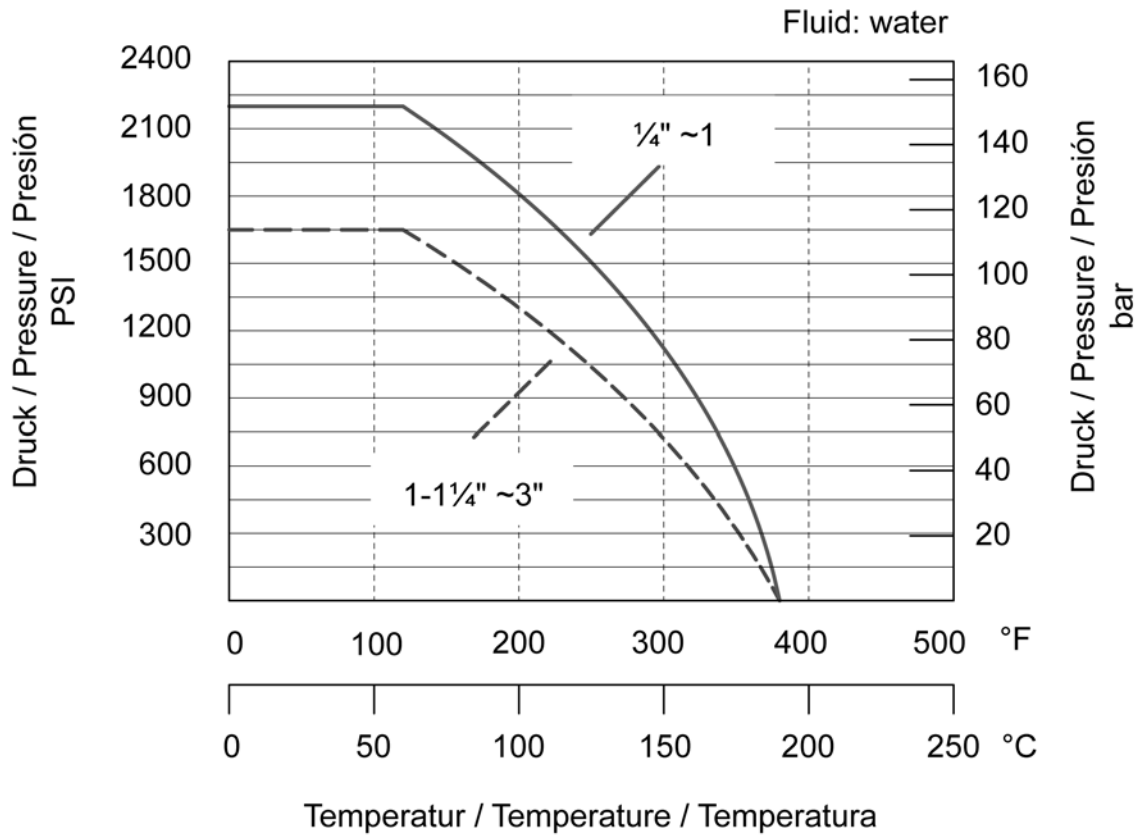

Niederdruck-Kugelhähne PN 130/100

beidseitig Innengewinde nach ISO 228/1

Low pressure ball valves PN 130/100

double-sided female thread to ISO 228/1

Llaves esféricas de baja presión PN 130/100

rosca interior en los dos lados según ISO 228/1

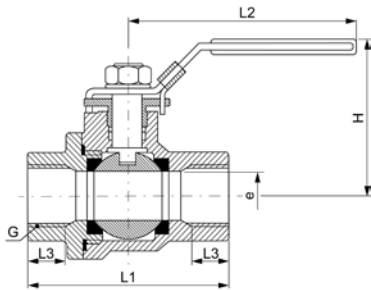

NKM-G PN 130/100

Type-G	Mat.-Nr.	PN	G	H	L1	L2	L3	e	g/Stk
G=Rohrgewinde (zylindrisch)		G=BSP thread (parallel)				G=rosca de conexión (cilíndrica)			
NKM-G 1.4 PN 130	808.8021.040	130	1/4	53.0	60.0	95.0	13.0	11.6	334
NKM-G 3.8 PN 130	808.8021.060	130	3/8	53.0	60.0	95.0	13.0	12.7	320
NKM-G 1.2 PN 130	808.8021.080	130	1/2	53.0	75.0	95.0	15.0	15.0	346
NKM-G 3.4 PN 130	808.8021.120	130	3/4	60.0	80.0	110.0	17.0	20.0	586
NKM-G 1.1 PN 130	808.8021.160	130	1	74.0	90.0	135.0	19.0	25.0	1035
NKM-G 5.4 PN 100	808.8021.180	100	1 1/4	80.0	111.0	135.0	21.0	32.0	1035
NKM-G 3.2 PN 100	808.8021.200	100	1 1/2	92.0	120.0	165.0	22.0	38.0	1800
NKM-G 4.2 PN 100	808.8021.220	100	2	101.0	140.0	200.0	22.0	50.0	4340

L3=minimal nutzbare Gewindetiefe

L3=useable thread length minimum

L3=profundidad de la rosca mínimamente usable

e=kleinster Innen-Ø

e=minimum inside diameter

e=Ø interior mínimo

Niederdruck-Kugelhähne PN 130 / 100

beidseitig Schneidringanschluss nach ISO 8434-1, ohne Mutter und Schneidring

Low pressure ball valves PN 130 / 100

both sides cutting ring connection to ISO 8434-1, without nut and cutting ring

Llaves esféricas de baja presión PN 130/100

conexión de anillo de corte en los dos lados según ISO 8434-1, sin tuerca y anillo cortante

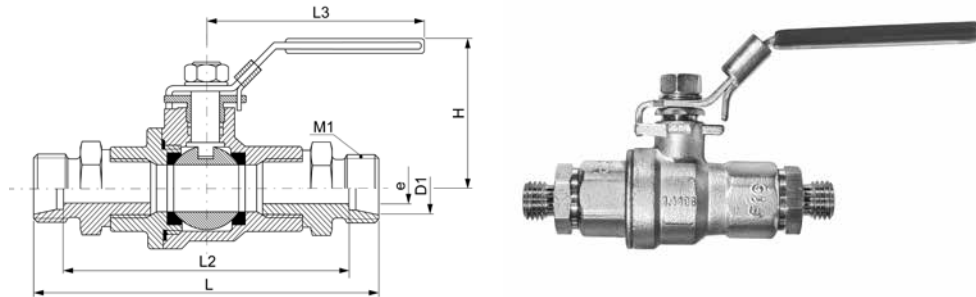

XNKS-PN 130/100

Type-D1	Mat.-Nr.	PN	M1	H	L	L2	L3	SW2	e	g/Stk
XNKS-06L PN 130	806.8020.060	130	12x1.5	53.0	94.0	80.0	95.0	19	4.0	396
XNKS-08L PN 130	806.8020.080	130	14x1.5	53.0	94.0	80.0	95.0	19	5.0	392
XNKS-10L PN 130	806.8020.100	130	16x1.5	53.0	96.0	82.0	95.0	19	7.0	394
XNKS-12L PN 130	806.8020.120	130	18x1.5	53.0	99.0	85.0	95.0	19	9.0	404
XNKS-15L PN 130	806.8020.150	130	22x1.5	53.0	117.0	103.0	95.0	24	11.0	492
XNKS-18L PN 130	806.8020.180	130	26x1.5	60.0	119.0	104.0	110.0	27	14.0	530
XNKS-22L PN 130	806.8020.220	130	30x2.0	60.0	128.0	113.0	110.0	32	18.0	790
XNKS-28L PN 130	806.8020.280	130	36x2.0	74.0	140.0	125.0	135.0	41	25.0	1370
XNKS-35L PN 100	806.8020.350	100	45x2.0	80.0	167.0	146.0	135.0	46	32.0	1925
XNKS-42L PN 100	806.8020.420	100	52x2.0	80.0	180.0	158.0	165.0	55	38.0	3315

D1=Rohr außen-Ø
M1=metrisches Anschlußgewinde
e=kleinster Innen-Ø

D1=tube outside diameter
M1=metric connecting thread
e=minimum inside diameter

D1=Ø exterior del tubo
M1=rosca métrica conexión
e=Ø interior mínimo

Niederdruck-Kugelhähne PN 130/100

beidseitig Schneidringanschluss nach ISO 8434-1

Low pressure ball valves PN 130/100

double-sided cutting ring connection to ISO 8434-1

Llaves esféricas de baja presión PN 130/100

conexión de anillo cortante en los dos lados según ISO 8434-1

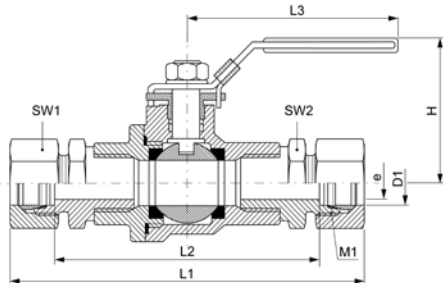

NKS-PN 130/100

Type-D1	Mat.-Nr.	PN	M1	H	L1	L2	L3	SW1	SW2	e	g/Stk
NKS-06L PN 130	808.8020.060	130	12x1.5	53.0	110.0	80.0	95.0	14	19	4.0	418
NKS-08L PN 130	808.8020.080	130	14x1.5	53.0	110.0	80.0	95.0	17	19	5.0	426
NKS-10L PN 130	808.8020.100	130	16x1.5	53.0	112.0	82.0	95.0	19	19	7.0	436
NKS-12L PN 130	808.8020.120	130	18x1.5	53.0	115.0	85.0	95.0	22	19	9.0	462
NKS-15L PN 130	808.8020.150	130	22x1.5	53.0	133.0	103.0	95.0	27	24	11.0	582
NKS-18L PN 130	808.8020.180	130	26x1.5	60.0	137.0	104.0	110.0	32	27	14.0	626
NKS-22L PN 130	808.8020.220	130	30x2.0	60.0	146.0	113.0	110.0	36	32	18.0	965
NKS-28L PN 130	808.8020.280	130	36x2.0	74.0	158.0	125.0	135.0	41	41	25.0	1580
NKS-35L PN 100	808.8020.350	100	45x2.0	80.0	189.0	146.0	135.0	50	46	32.0	2250
NKS-42L PN 100	808.8020.420	100	52x2.0	80.0	204.0	158.0	165.0	60	55	38.0	3825

Baumaße sind Ungefährmaße bei angezogener Überwurfmutter.

Sizes are approximate dimensions at tightened nut.

Las medidas son aproximadas con la tuerca de unión apretada.

Artikel bis 22L auch als NC Ausführung erhältlich.

Articles up to 22L also available as NC version.

Los artículos hasta 22L también están disponibles en versión NC.

D1=Rohr außen-Ø
M1=metrisches Anschlußgewinde
e=kleinster Innen-Ø

D1=tube outside diameter
M1=metric connecting thread
e=minimum inside diameter

D1=Ø exterior del tubo
M1=rosca métrica conexión
e=Ø interior mínimo

Technische Informationen

Technical Information

Información Técnica

**Niederdruck-Kugelhahn
PN 63**

**Low Pressure Ball Valve
PN 63**

**Llave esférica de baja presión
PN 63**

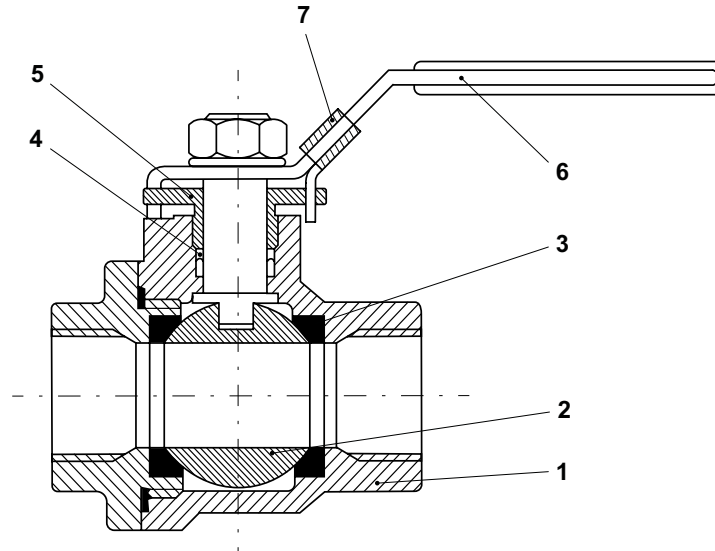

	Bauteil Part Componente	Werkstoff Material Material
1	Gehäuse Body Carcasa	Edelstahl 1.4408 / AISI 316 Stainless steel 1.4408 / AISI 316 Acero inoxidable 1.4408 / AISI 316
2	Kugel Ball Bola	Edelstahl 1.4408 / AISI 316 Stainless steel 1.4408 / AISI 316 Acero inoxidable 1.4408 / AISI 316
3	Dichtung Sealing Junta	PTFE PTFE PTFE
4	Spindeldichtung Stem sealing Junta husillo	PTFE PTFE PTFE
5	Stopfbuchse Gland Prensaestopas	Edelstahl 1.4301 / AISI 304 Stainless steel 1.4301 / AISI 304 Acero inoxidable 1.4301 / AISI 304
6	Hebel Handle Palanca	Edelstahl 1.4301 / AISI 304 Stainless steel 1.4301 / AISI 304 Acero inoxidable 1.4301 / AISI 304
7	Abschliessvorrichtung Locking device Posicionador da cerrar	Edelstahl 1.4301 / AISI 304 Stainless steel 1.4301 / AISI 304 Acero inoxidable 1.4301 / AISI 304

2-teilig

Voller Durchgang
Innengewinde ISO 228/1 oder NPT
Druck: 63 bar / ¼" bis 2"
Sicherheitsfaktor: 1.5-fach
Dichtung: PTFE
Temperatur: -50°C bis +180°C

2-parts

Full bore
Female thread ISO 228/1 or NPT
Pressure: 63 bar (1000 psi) / ¼" to 2"
Safety factor: 1.5 times
Sealing: PTFE
Temperature: -50°C to +180°C

2 piezas

Paso total
Rosca interior ISO 228/1 o NPT
Presión: 63 bar / ¼" a 2"
Factor de seguridad: 1.5 veces
Junta: PTFE
Temperatura: -50°C a +180°C

Druck-Temperatur-Diagramm

Niederdruck-Kugelhahn PN 63

Pressure-Temperature-Diagram

Low pressure ball valve PN 63

Diagrama de presión y temperatura

Llave esférica de baja presión PN 63

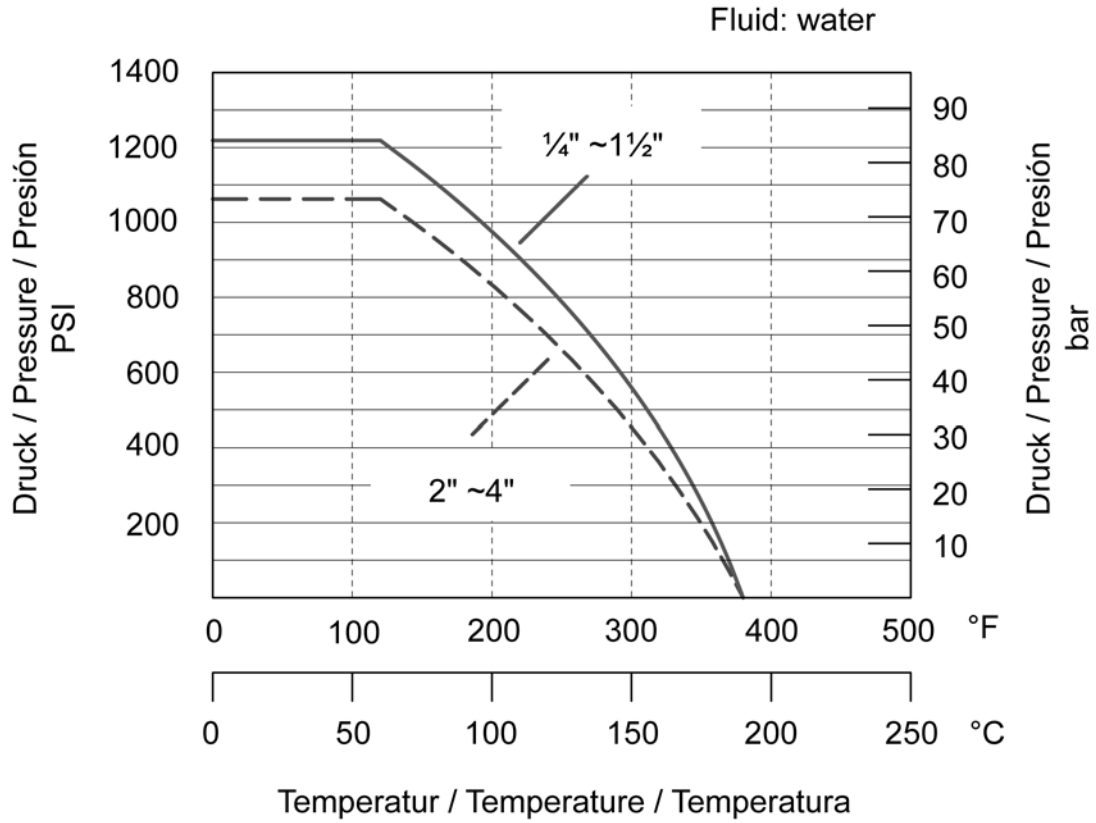

Niederdruck-Kugelhähne PN 63

beidseitig Innengewinde nach ISO 228/1

Low pressure ball valves PN 63

double-sided female thread to ISO 228/1

Llaves esféricas de baja presión PN 63

rosca interior en los dos lados según ISO 228/1

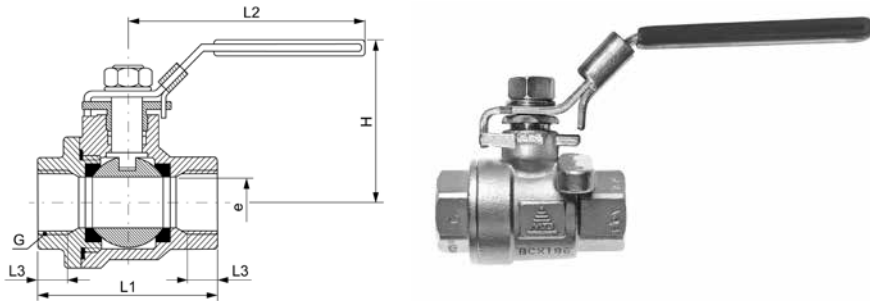

NKM-G PN 63

Type-G	Mat.-Nr.	PN	G	H	L1	L2	L3	e	g/Stk
G=Rohrgewinde (zylindrisch)		G=BSP thread (parallel)				G=rosca de conexión (cilíndrica)			
NKM-G 1.4 PN 63	808.8022.040	63	1/4	51.0	45.0	95.0	6.0	11.6	334
NKM-G 3.8 PN 63	808.8022.060	63	3/8	51.0	44.5	95.0	6.0	12.7	320
NKM-G 1.2 PN 63	808.8022.080	63	1/2	53.0	57.0	95.0	8.0	15.0	346
NKM-G 3.4 PN 63	808.8022.120	63	3/4	59.5	65.0	110.0	9.0	20.0	586
NKM-G 1.1 PN 63	808.8022.160	63	1	73.0	76.0	135.0	12.0	25.0	1035
NKM-G 5.4 PN 63	808.8022.180	63	1 1/4	79.0	87.5	135.0	13.0	32.0	1035
NKM-G 3.2 PN 63	808.8022.200	63	1 1/2	100.0	102.0	165.0	16.0	38.0	2610
NKM-G 4.2 PN 63	808.8022.220	63	2	99.0	121.0	165.0	20.0	50.0	2710

Nur für kegelige Einschraubgewinde geeignet.

Only suitable for tapered threads.

Sólo apto para rosca cónica.

Niederdruck-Kugelhähne NPT PN 63

beidseitig Innengewinde NPT nach ANSI B 1.20.1 - 1983

Low pressure ball valves NPT PN 63

double-sided female thread NPT to ANSI B 1.20.1 - 1983

Llaves esféricas de baja presión NPT PN 63

rosca interior NPT en los dos lados según ANSI B 1.20.1 - 1983

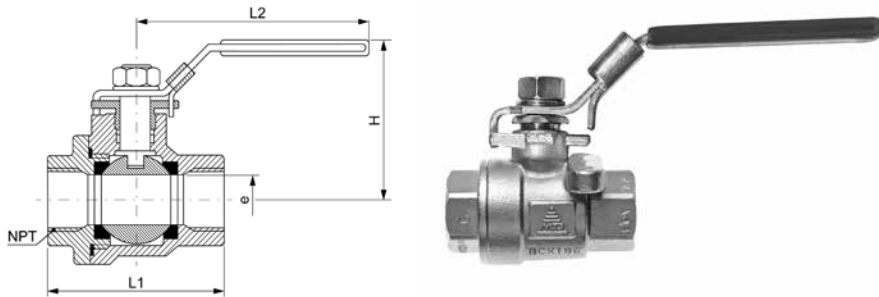

NKM-NPT PN 63

Type -NPT	Mat.-Nr.	PN	NPT	H	L1	L2	e	g/Stk
NPT=Einschraubgewinde NPT		NPT=tapered male adaptor thread NPT			NPT=rosca de conexión cónica NPT			
NKM-NPT 1.4 PN 63	808.8023.040	63	1/4	51.0	45.0	95.0	11.6	233
NKM-NPT 3.8 PN 63	808.8023.060	63	3/8	51.0	45.0	95.0	12.7	320
NKM-NPT 1.2 PN 63	808.8023.080	63	1/2	53.0	57.0	95.0	15.0	346
NKM-NPT 3.4 PN 63	808.8023.120	63	3/4	60.0	65.0	110.0	20.0	453
NKM-NPT 1.1 PN 63	808.8023.160	63	1	73.0	76.0	135.0	25.0	751
NKM-NPT 5.4 PN 63	808.8023.180	63	1 1/4	79.0	87.0	135.0	32.0	1106
NKM-NPT 3.2 PN 63	808.8023.200	63	1 1/2	91.0	102.0	165.0	38.0	1872
NKM-NPT 4.2 PN 63	808.8023.220	63	2	99.0	121.0	165.0	50.0	4340

PN 130 auf Anfrage erhältlich.

PN 130 is available on request.

PN 130 disponible bajo demanda.

e=kleinster Innen-Ø

e=minimum inside diameter

e=Ø interior mínimo

Technische Informationen

Technical Information

Información Técnica

**Hochdruck-Kugelhahn
PN 500**

**High Pressure Ball Valve
PN 500**

**Llave esférica de alta presión
PN 500**

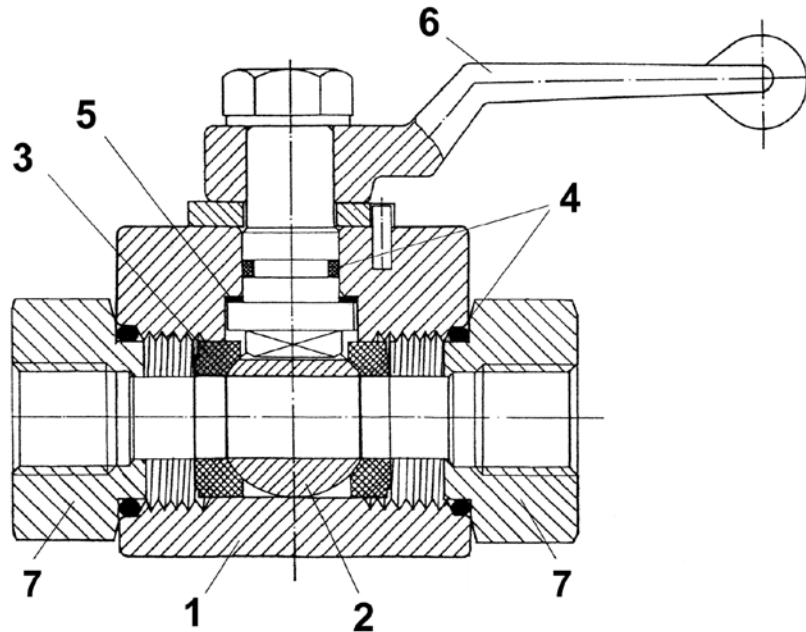

	Bauteil Part Componente	Werkstoff Material Material
1	Gehäuse Body Carcasa	Edelstahl 1.4571 / AISI 316 Ti Stainless steel 1.4571 / AISI 316 Ti Acero inoxidable 1.4571 / AISI 316 Ti
2	Kugel Ball Bola	Edelstahl 1.4571 / AISI 316 Ti Stainless steel 1.4571 / AISI 316 Ti Acero inoxidable 1.4571 / AISI 316 Ti
3	Dichtschale Sealing bush Asiento	POM; Sonderausführung PEEK auf Anfrage POM; special sealing PEEK on request POM; versión especial PEEK bajo demanda
4	Dichtung Sealing Junta	O-Ring FKM O-ring FKM Junta tórica FKM
5	Anlaufscheibe Washer Arandela tope	POM; Sonderausführung PEEK auf Anfrage POM; special sealing PEEK on request POM; versión especial PEEK bajo demanda
6	Hebel Handle Palanca	Edelstahl 1.4571 / AISI 316 Ti Stainless steel 1.4571 / AISI 316 Ti Acero inoxidable 1.4571 / AISI 316 Ti
7	Verschraubungen Adapters Raccorrs	Edelstahl 1.4571 / AISI 316 Ti Stainless steel 1.4571 / AISI 316 Ti Acero inoxidable 1.4571 / AISI 316 Ti

Druck-Temperatur-Diagramm

Hochdruck-Kugelhahn
POM + PEEK

Pressure-Temperature-Diagram

High pressure ball valve
POM + PEEK

Diagrama de presión y temperatura

Llave esférica de alta presión
POM + PEEK

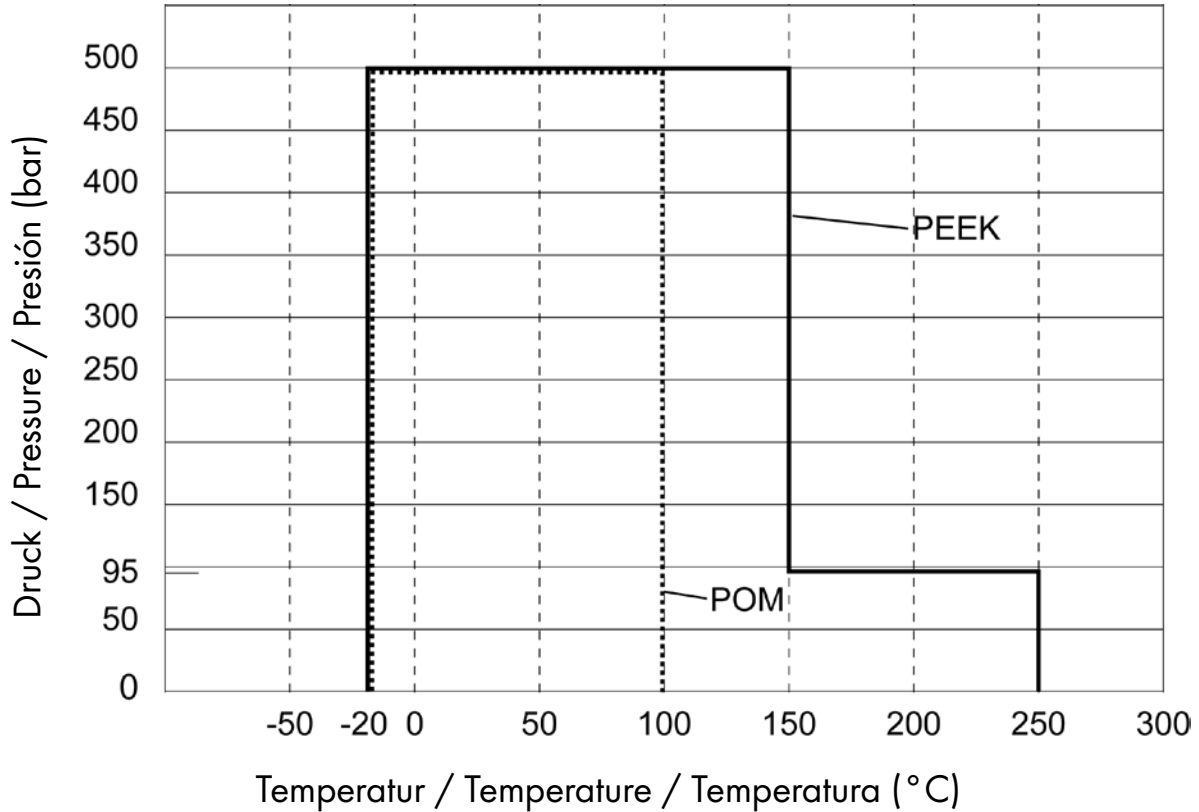

50

Achtung!

Bei Bestellungen von Hochdruck-Kugelhähnen mit Sonderdichtschalen aus Werkstoff PEEK ist zur Typenbezeichnung der Zusatz "PEEK" erforderlich.

Hochdruck-Kugelhähne sind auf Anfrage mit pneumatischem (einfach oder doppelt wirkend) oder elektrischem Antrieb erhältlich. Fragen Sie nach unserer Checkliste.

Anmerkung:

Der maximal mögliche Betriebsdruck PN kann auf Grund der Anschlüsse unter dem als maximal angegebenen Nenndruck PN liegen. Sicherheitsfaktor: 1.5-fach

Attention!

For orders of high pressure ball valves with special sealing bushes in material PEEK, it is necessary to add "PEEK" to the type of the standard valves.

High pressure ball valves are available on request with pneumatic (single or double acting) or electric actuator. Ask for our checklist.

Remark:

Due to the connectors, the maximum possible working pressure PN can be lower than the maximum nominal pressure PN specified.. Safety factor: 1.5 times

Atención!

Para pedidos de llaves esféricas de alta presión con asientos especiales de PEEK debe añadirse el código "PEEK".

Las válvulas de bola de alta presión están disponibles bajo pedido con actuador neumático (simple o doble efecto) o eléctrico. Solicite nuestra lista de control.

Nota:

Por cuestiones relacionadas con las conexiones, la presión de servicio máxima PN puede ser menor que la presión nominal PN señalada. Factor de seguridad: 1.5 veces

Hochdruck-Kugelhähne

beidseitig Innengewinde nach ISO 228/1

High pressure ball valves

double-sided female thread to ISO 228/1

Llaves esféricas de alta presión

rosca interior en los dos lados según ISO 228/1

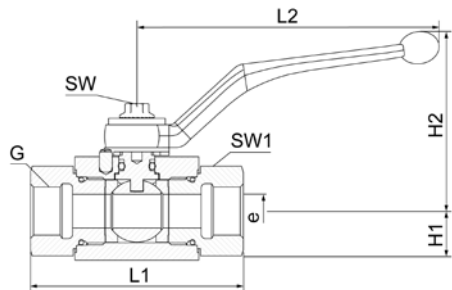

HKM-G

Type-G	Mat.-Nr.	DN	PN	G	H1	H2	L1	L2	SW	SW1	e	g/Stk
G=Rohrgewinde (zylindrisch)		G=BSP thread (parallel)					G=rosca de conexión (cilíndrica)					
HKM-G 1.8	808.8100.020	04	500	1/8	13.5	71.5	69.0	115.0	9	22	5.0	410
HKM-G 1.4	808.8100.040	06	500	1/4	13.5	71.5	69.0	115.0	9	22	6.0	400
HKM-G 3.8	808.8100.060	10	500	3/8	17.5	72.5	72.0	115.0	9	27	10.0	540
HKM-G 1.2	808.8100.080	13	500	1/2	19.0	73.0	83.0	115.0	9	30	13.0	650
HKM-G 3.4	808.8100.120	20	350	3/4	24.5	86.5	95.0	160.0	14	41	20.0	1500
HKM-G 1.1	808.8100.160	25	350	1	29.5	89.5	113.0	160.0	14	50	25.0	2200
HKM-G 5.4	808.8100.180	25	315	1 1/4	29.5	89.5	120.0	160.0	14	55	25.0	2300

e=kleinster Innen-Ø

e=minimum inside diameter

e=Ø interior mínimo

Hochdruck-Kugelhähne NPT

beidseitig Innengewinde NPT nach ANSI B 1.20.1 - 1983

High pressure ball valves NPT

double-sided female thread to ANSI B 1.20.1 - 1983

Llaves esféricas de alta presión NPT

rosca interior en los dos lados NPT según ANSI B 1.20.1 - 1983

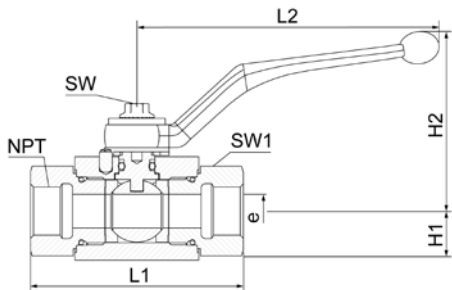

HKM-NPT

Type -NPT	Mat.-Nr.	DN	PN	NPT	H1	H2	L1	L2	SW	SW1	e	g/Stk
NPT=Einschraubgewinde NPT		NPT=tapered male adaptor thread NPT			NPT=rosca de conexión cónica NPT							
HKM-NPT 1.8	808.8113.020	04	500	1/8	13.5	71.5	69.0	115.0	9	22	5.0	300
HKM-NPT 1.4	808.8113.040	06	500	1/4	13.5	71.5	69.0	115.0	9	22	6.0	400
HKM-NPT 3.8	808.8113.060	10	500	3/8	17.5	72.5	72.0	115.0	9	27	10.0	550
HKM-NPT 1.2	808.8113.080	13	500	1/2	19.0	73.0	83.0	115.0	9	30	13.0	750
HKM-NPT 3.4	808.8113.120	20	315	3/4	24.5	86.5	95.0	160.0	14	41	20.0	1630
HKM-NPT 1.1	808.8113.180	25	315	1	29.5	89.5	113.0	160.0	14	50	25.0	2300

50

e=kleinster Innen-Ø

e=minimum inside diameter

e=Ø interior mínimo

Hochdruck-Kugelhähne

beidseitig Rohranschluss nach ISO 8434-1, ohne Mutter und Schneidring

High pressure ball valves

double-sided tube connection to ISO 8434-1, without nut and cutting ring

Llaves esféricas de alta presión

conexión de tubos en los dos lados según ISO 8434-1, sin tuerca y anillo cortante

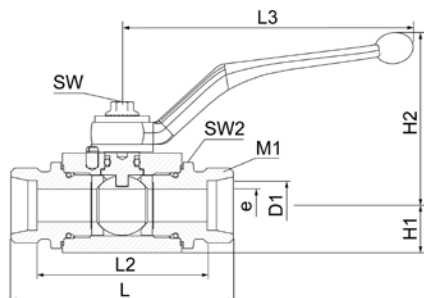

XHKS-..L/S

Type-D1	Mat.-Nr.	DN	PN	M1	H1	H2	L	L2	L3	SW	SW2	e	g/Stk
XHKS-06L	806.8114.060.20	04	500	12x1.5	13.5	71.5	67.0	53.0	115.0	9	22	5.0	360
XHKS-08L	806.8114.080.20	06	500	14x1.5	13.5	71.5	67.0	53.0	115.0	9	22	6.0	370
XHKS-10L	806.8114.100.20	08	500	16x1.5	13.5	71.5	74.0	60.0	115.0	9	22	8.0	380
XHKS-12L	806.8114.120.20	10	400	18x1.5	17.5	72.5	74.0	60.0	115.0	9	27	10.0	500
XHKS-15L	806.8114.150.20	13	400	22x1.5	19.0	73.0	82.0	68.0	115.0	9	30	13.0	610
XHKS-18L	806.8114.180.20	13	400	26x1.5	19.0	73.0	82.0	67.0	115.0	9	30	13.0	600
XHKS-22L	806.8114.220.20	20	250	30x2.0	24.5	86.5	101.0	86.0	160.0	14	41	20.0	1490
XHKS-28L	806.8114.280.20	25	250	36x2.0	29.5	89.5	108.0	93.0	160.0	14	50	25.0	2000
XHKS-35L	806.8114.350.20	25	250	45x2.0	29.5	89.5	112.0	91.0	160.0	14	50	25.0	2120
XHKS-08S	806.8114.080.30	04	500	16x1.5	13.5	71.5	73.0	59.0	115.0	9	22	5.0	380
XHKS-10S	806.8114.100.30	06	500	18x1.5	13.5	71.5	73.0	58.0	115.0	9	22	6.0	390
XHKS-12S	806.8114.120.30	08	500	20x1.5	13.5	71.5	76.0	61.0	115.0	9	22	8.0	390
XHKS-14S	806.8114.140.30	10	500	22x1.5	17.5	72.5	80.0	64.0	115.0	9	27	10.0	500
XHKS-16S	806.8114.160.30	13	500	24x1.5	19.0	73.0	86.0	69.0	115.0	9	30	13.0	600
XHKS-20S	806.8114.200.30	13	420	30x2.0	19.0	73.0	90.0	69.0	115.0	9	32	13.0	600
XHKS-25S	806.8114.250.30	20	315	36x2.0	24.5	86.5	109.0	85.0	160.0	14	41	20.0	1650
XHKS-30S	806.8114.300.30	25	315	42x2.0	29.5	89.5	120.0	93.0	160.0	14	50	25.0	2100
XHKS-38S	806.8114.380.30	25	315	52x2.0	29.5	89.5	124.0	92.0	160.0	14	60	25.0	2150

D1=Rohr außen-Ø
M1=metrisches Anschlußgewinde
e=kleinster Innen-Ø

D1=tube outside diameter
M1=metric connecting thread
e=minimum inside diameter

D1=Ø exterior del tubo
M1=rosca métrica conexión
e=Ø interior mínimo

Hochdruck-Kugelhähne

beidseitig Schneidringanschluss nach ISO 8434-1

High pressure ball valves

double-sided cutting ring connection to ISO 8434-1

Llaves esféricas de alta presión

conexión de anillo cortante en los dos lados según ISO 8434-1

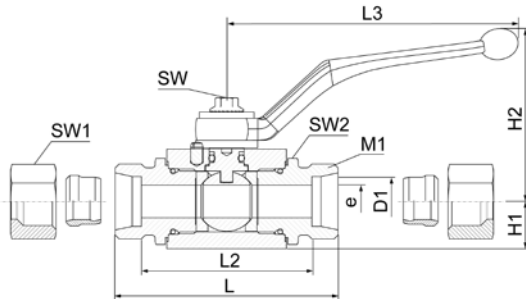

HKS-..L/S

Type-D1	Mat.-Nr.	DN	PN	M1	H1	H2	L1	L2	L3	SW	SW1	SW2	e	g/Stk
HKS-06L	808.8114.060.20	04	500	12x1.5	13.5	71.5	83.0	53.0	115.0	9	14	22	5.0	384
HKS-08L	808.8114.080.20	06	500	14x1.5	13.5	71.5	83.0	53.0	115.0	9	17	22	6.0	404
HKS-10L	808.8114.100.20	08	500	16x1.5	13.5	71.5	91.0	60.0	115.0	9	19	22	8.0	424
HKS-12L	808.8114.120.20	10	400	18x1.5	17.5	72.5	92.0	60.0	115.0	9	22	27	10.0	554
HKS-15L	808.8114.150.20	13	400	22x1.5	19.0	73.0	100.0	68.0	115.0	9	27	30	13.0	700
HKS-18L	808.8114.180.20	13	400	26x1.5	19.0	73.0	100.5	66.5	115.0	9	32	30	13.0	734
HKS-22L	808.8114.220.20	20	250	30x2.0	24.5	86.5	120.0	86.0	160.0	14	36	41	20.0	1664
HKS-28L	808.8114.280.20	25	250	36x2.0	29.5	89.5	127.5	93.0	160.0	14	41	50	25.0	2198
HKS-35L	808.8114.350.20	25	250	45x2.0	29.5	89.5	136.0	91.0	160.0	14	50	50	25.0	2438
HKS-08S	808.8114.080.30	04	500	16x1.5	13.5	71.5	90.0	59.0	115.0	9	19	22	5.0	422
HKS-10S	808.8114.100.30	06	500	18x1.5	13.5	71.5	92.5	58.0	115.0	9	22	22	6.0	454
HKS-12S	808.8114.120.30	08	500	20x1.5	13.5	71.5	95.5	61.0	115.0	9	24	22	8.0	464
HKS-14S	808.8114.140.30	10	500	22x1.5	17.5	72.5	101.5	64.0	115.0	9	27	27	10.0	608
HKS-16S	808.8114.160.30	13	500	24x1.5	19.0	73.0	110.0	68.5	115.0	9	30	30	13.0	736
HKS-20S	808.8114.200.30	13	420	30x2.0	19.0	73.0	114.5	68.5	115.0	9	36	32	13.0	822
HKS-25S	808.8114.250.30	20	315	36x2.0	24.5	86.5	137.0	85.0	160.0	14	46	41	20.0	2092
HKS-30S	808.8114.300.30	25	315	42x2.0	29.5	89.5	149.0	93.0	160.0	14	50	50	25.0	2586
HKS-38S	808.8114.380.30	25	315	52x2.0	29.5	89.5	154.0	93.0	160.0	14	55	60	25.0	2900

50

Baumaße sind Ungefährmaße bei angezogener Überwurfmutter.

Sizes are approximate dimensions at tightened nut.

Las medidas son aproximadas con la tuerca de unión apretada.

Artikel bis 22L und 25S auch als NC Ausführung erhältlich.

Articles up to 22L and 25S also available as NC version.

Los artículos hasta 22L y 25S también están disponibles en versión NC.

D1=Rohr außen-Ø
M1=metrisches Anschlußgewinde
e=kleinster Innen-Ø

D1=tube outside diameter
M1=metric connecting thread
e=minimum inside diameter

D1=Ø exterior del tubo
M1=rosca métrica conexión
e=Ø interior mínimo

Kugelhähne, Ventile

Ball valves, Valves

Llaves esféricas, Válvulas

Zubehör für Hochdruckkugelhähne HKM/HKS

Accessory for high pressure ball valves HKM/HKS

Accesorios para llaves esféricas de alta presión HKM/HKS

**Dichtungssätze POM
Seal kits POM
Conjuntos de juntas POM**



Materialnummer Part-No. No. de materiale	Bezeichnung Designation Designación	geeignet für suitable for apropiado para
803.8102.040	DS-DN04 POM	HKM-G 1.8, HKM-NPT 1.8, (X)HKS-06L/08S
803.8102.060	DS-DN06 POM	HKM-G 1.4, HKM-NPT 1.4, (X)HKS-08L/10S
803.8102.080	DS-DN08 POM	(X)HKS-10L/12S
803.8102.100	DS-DN10 POM	HKM-G 3.8, HKM-NPT 3.8, (X)HKS-12L/14S
803.8102.130	DS-DN13 POM	HKM-G 1.2, HKM-NPT 1.2, (X)HKS-15L/18L/16S/20S
803.8102.200	DS-DN20 POM	HKM-G 3.4, HKM-NPT 3.4, (X)HKS-22L/25S
803.8102.250	DS-DN25 POM	HKM-G 1.1/5.4, HKM-NPT 1.1, (X)HKS-28L/35L/30S

Hinweis: Das Austauschen des Dichtungssatzes darf nur von geeignetem Fachpersonal durchgeführt werden, da fehlerhafte Montage ein Gefahrenpotential in sich birgt. Auf Wunsch sind Dichtungssätze PEEK lieferbar.

Notice: Only qualified technicians may replace the sealing set as improper assembly poses a potential risk. PEEK seal kits are available on request.

Advertencia: La sustitución del conjunto de juntas debe ser realizada exclusivamente por personal técnico adecuado, ya que un montaje incorrecto podría conllevar peligros. Conjuntos de juntas PEEK están disponibles bajo demanda.

**Griffe
Handles
Palancas**

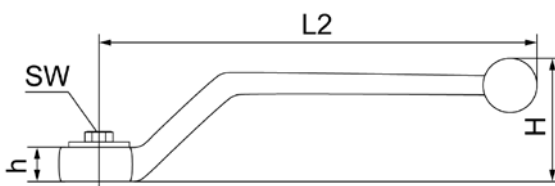

Materialnummer Part-No. No. de materiale	Bezeichnung Designation Designación	SW	h	L2	H	geeignet für suitable for apropiado para
805.8019.100	HS-SW9-VA	9	9	115	47	HKM-G 1.8/1.4/3.8/1.2 HKM-NPT 1.8/1.4/3.8/1.2 (X)HKS-06L - 18L / 08S - 20S
805.8019.200	HS-SW14-VA	14	12	160	48	HKM-G 3.4/1.1/5.4 HKM-NPT 3.4/1.1 (X)HKS-22L - 35L / 25S - 38S

Material: Edelstahl

Material: Stainless steel

Material: acero inoxidable

Kugelhähne, Ventile

Ball valves, Valves

Llaves esféricas, Válvulas

Zubehör für Hochdruckkugelhähne HKM/HKS

Accessory for high pressure ball valves HKM/HKS

Accesorios para llaves esféricas de alta presión HKM/HKS

**Abschliessvorrichtungen
Locking device
Posicionador da cerrar**

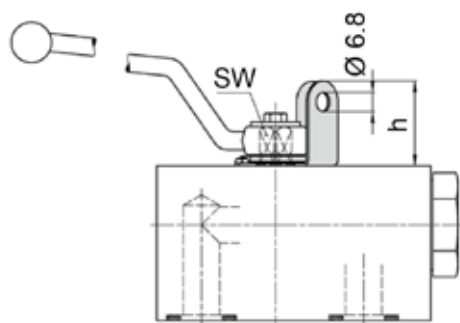

Materialnummer Part-No. No. de materiale	Bezeichnung Designation Designación	SW	h	geeignet für suitable for apropiado para
803.8500.090	ASV-SW9-VA	9	28.0	HKM-G 1.8/1.4/3.8/1.2 HKM-NPT 1.8/1.4/3.8/1.2 (X)HKS-06L - 18L / 08S - 20S
803.8500.140	ASV-SW14-VA	14	34.5	HKM-G 3.4/1.1/5.4 HKM-NPT 3.4/1.1 (X)HKS-22L - 35L / 25S - 38S

Material: Edelstahl

Material: Stainless steel

Material: acero inoxidable

50

**Automatische Antriebe
Automatic Actuators
Accionamientos Automáticos**



Für unsere Hochdruck-Kugelhähne sind zwei Arten von automatischen Antrieben erhältlich: elektrischer oder pneumatischer Antrieb.

Two types of automatic actuators are available for our high pressure ball valves: electric or pneumatic actuator.

Hay dos tipos de accionamientos automáticos para nuestras llaves esféricas de alta presión: el accionamiento eléctrico o el neumático.

Basierend auf Ihren Anforderungen arbeiten wir gerne ein passendes Angebot aus. Bitte kontaktieren Sie unseren Verkauf.

Based on your requirements we will be pleased to work out a customized offer. Please contact our sales department.

En base a sus requerimientos estaremos encantados de elaborar una oferta personalizada. Por favor, contacte con nuestro departamento de ventas.

Einbaufertige Rohrleitungen

Jährlich konfektionieren wir über 150'000 m Metallrohre. Den Großteil davon biegen und verpressen wir mit Verschraubungen und Ventilen für kundenspezifische Lösungen. Unsere einbaufertigen Rohre finden in vielen Branchen Anwendung, sie sind in Kaffeemaschinen genauso verbaut wie in Schienenfahrzeugen.

Konfektioniert mit EXMAR Schneidring-Komponenten

Wir konfektionieren für Sie unsere Rohre mit Schneidring-Verschraubungen, -Ventilen, -Kugelhähnen und anderen Teilen aus dem EXMAR-Sortiment. Durch den großen Lagerbestand in Frauenfeld profitieren Sie von kurzen Reaktionszeiten und einem schnellen, flexiblen Service.

Konfektioniert mit EXMAR NC Klemmring-Komponenten

Besonders für Anwendungen mit erhöhter korrosiver Beanspruchung empfehlen wir den Einsatz unserer Klemmringanschlüsse. Ihnen steht ein ebenso großes Sortiment in den Anschlussgrößen 6 bis 25 mm zur Verfügung.

Konfektioniert mit Sonderteilen

Immer gefragter sind orbitalgeschweisste oder vakuumgelötete Komponenten. Dank unserer langjährigen Erfahrungen und professionellen Partnern können wir Ihnen auch hier eine passende Lösung bieten. Natürlich verpressen wir auf Kundenwunsch auch Komponenten von SERTO oder von Mitbewerbern. Ganz gleich, ob diese vom Kunden mitgeliefert werden oder wir sie nach seinen Angaben selber beschaffen.

Beispiele



Ready-to-fit pipelines

We assemble over 150,000 metres of metal pipes per year. We bend and press most of these with unions, valves and couplings for customer-specific solutions. Our ready-to-fit pipes are applied in many sectors, installed in everything from coffee machines to rail vehicles.

Pre-assembled with EXMAR cutting ring components

We assemble our pipes for you with cutting ring unions, valves, ball valves and other parts from the EXMAR range. Due to the large amount of warehouse stock in Frauenfeld, you can benefit from short reaction times and fast and flexible service.

Pre-assembled with EXMAR NC clamping ring components

Especially for applications with increased corrosive stress we recommend the use of our clamping ring connections. You can choose from an equally large range of connection sizes from 6 to 25 mm.

Pre-assembled with special parts

Orbital-welded or vacuum-welded components are increasingly in demand. We can also offer you a suitable solution for this requirement thanks to our many years of experience and professional partners. Of course, we also press components from competitors if a customer requests this. This applies whether these are supplied by the customer or if we purchase them ourselves in accordance with the customer requirements.

Examples

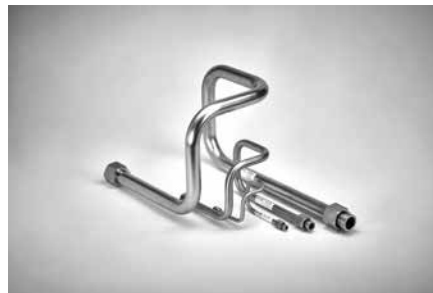

Tuberías listas para ser instaladas

Ensamblamos más de 150.000 metros de tubos de metal por año. Doblamos y prensamos la mayoría de ellos con uniones, válvulas y acoplamientos para soluciones específicas del cliente. Nuestros tubos listos para montar se aplican en muchos sectores, instalados en todo, desde máquinas de café hasta vehículos ferroviarios.

Premontados con componentes de anillo cortante EXMAR

Ensamblamos nuestros tubos con uniones de anillo cortante, válvulas, válvulas de bola y otros productos de la gama EXMAR. Debido a la gran cantidad de existencias en el almacén de Frauenfeld, puede beneficiarse de tiempos de reacción cortos y un servicio ágil y rápido.

Premontado con componentes de anillos de apriete EXMAR NC

Especialmente para aplicaciones con un mayor estrés corrosivo recomendamos el uso de nuestras conexiones de anillo de apriete. Puede elegir entre una gama igualmente amplia de tamaños de conexión de 6 a 25 mm.

Premontado con piezas especiales

Los componentes con soldadura orbital o de vacío tienen cada vez más demanda. Gracias a nuestros muchos años de experiencia y a nuestros socios profesionales, también podemos ofrecerle una solución adecuada para esta necesidad. Por supuesto, también prensamos componentes de la competencia si un cliente lo solicita. Esto se aplica tanto si son suministrados por el cliente como si los compramos nosotros mismos de acuerdo con los requisitos del cliente.

Ejemplos



Technische Informationen

Technical Information

Información Técnica

Rückschlagventil

Non-return valve

Válvula de retención

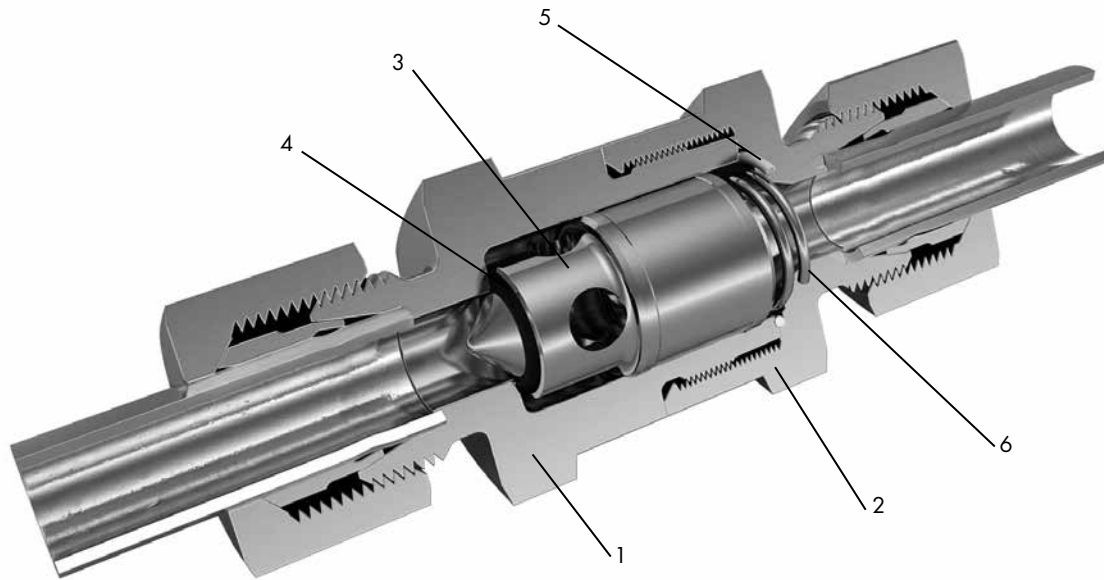

	Bauteil Part Componente	Werkstoff Material Material
1	Ventilkegelführung Valve cone guide Guía de cono de válvula	Edelstahl 1.4571 / AISI 316 Ti Stainless steel 1.4571 / AISI 316 Ti Acero inoxidable 1.4571 / AISI 316 Ti
2	Ventilmutter Valve nut Tuerca de válvula	Edelstahl 1.4571 / AISI 316 Ti Stainless steel 1.4571 / AISI 316 Ti Acero inoxidable 1.4571 / AISI 316 Ti
3	Ventilkegel Valve cone Cono de válvula	Edelstahl 1.4571 / AISI 316 Ti Stainless steel 1.4571 / AISI 316 Ti Acero inoxidable 1.4571 / AISI 316 Ti
4	Dichtung Kegel* Sealing cone* Junta de cono*	O-Ring FKM (Optionen auf Anfrage) O-ring FKM (Options on request) Junta tórica FKM (opciones a petición)
5	Dichtung Sealing Junta	PTFE PTFE PTFE
6	Druckfeder Compression spring Resorte de compresión	Edelstahl 1.4401 / AISI 316 Stainless steel 1.4401 / AISI 316 Acero inoxidable 1.4401 / AISI 316

Spezifikationen

Nennndruck (PN): 100 bis 800 bar
Temperatur: -20 °C bis +200 °C
Öffnungsdruck: 1 bar +/- 20 %
Sicherheitsfaktor: 1.5-fach

Optionen

Öffnungsdruck: 0.2/0.5/2/3/5 bar,
+/- 20 % (mind. +/- 0.1 bar)
*Dichtung Kegel: EPDM, PTFE, NBR

Specifications

Nom. pressure (PN): 100 to 800 bar
Temperature: -20 °C to +200 °C
Opening pressure: 1 bar +/- 20 %
Safety factor: 1.5 times

Options

Opening pressure: 0.2/0.5/2/3/5 bar,
+/- 20 % (min. +/- 0.1 bar)
*Sealing cone: EPDM, PTFE, NBR

Especificaciones

Presión nom. (PN): 100 a 800 bar
Temperatura: -20 °C a +200 °C
Presión de apertura: 1 bar +/- 20 %
Factor de seguridad: 1.5 veces

Opciones

Presión de apertura: 0.2/0.5/2/3/5 bar,
+/- 20 % (min. +/- 0.1 bar)
*Junta de cono: EPDM, PTFE, NBR

Durchflussdiagramm

Der Druckabfall nimmt mit zunehmendem Durchfluss überproportional zu.

Flow rate

The pressure drop increases disproportionately with increasing flow rate.

Diagrama de flujo

La pérdida de presión aumenta de manera sobreproporcional con el incremento del flujo.

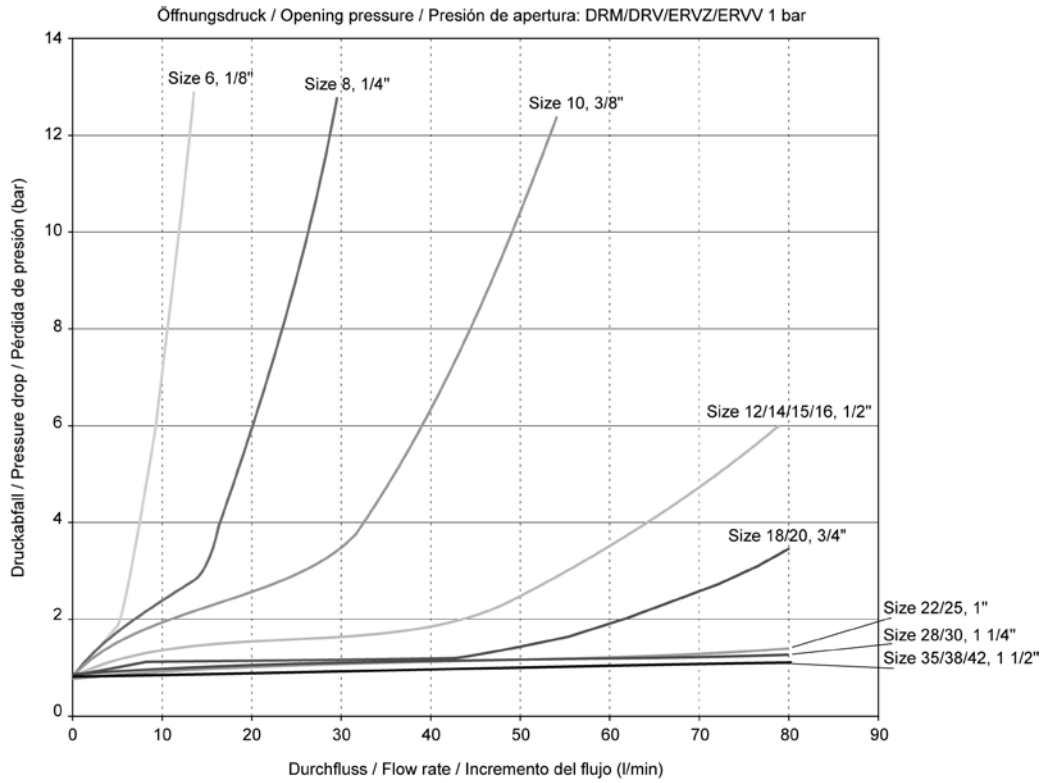

Öffnungsdruckdiagramm

Der Öffnungsdruck bewegt sich im hell skizzierten Bereich (1). Das Ventil schliesst spätestens im dunkel skizzierten Bereich (2).

Opening pressure diagram

The opening pressure ranges within the light marked section (1). The valve closes latest within the dark marked section (2).

Diagrama de presión de apertura

La presión de apertura varía en la zona en color claro (1). La válvula se cierra en la zona en color oscuro (2).

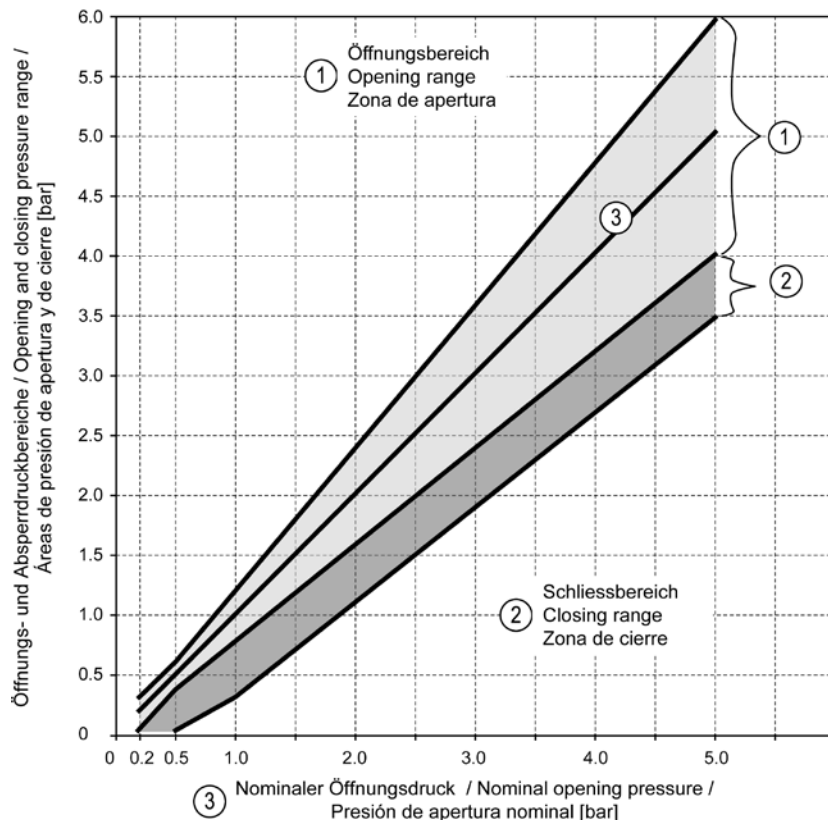

Rückschlagventile

beidseitig Innengewinde

Non-return valves

double-sided female thread

Válvulas de retención

rosca interior en los dos lados

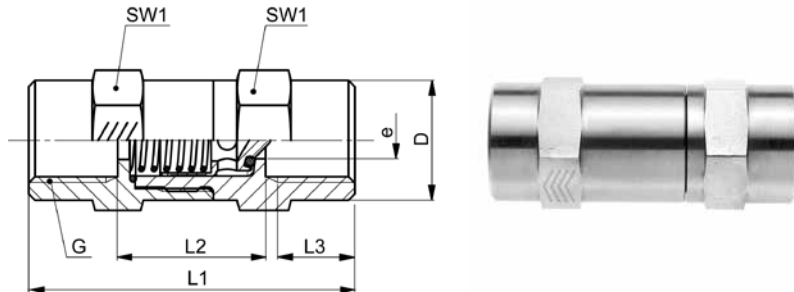

DRM-..

Type-G	Mat.-Nr.	PN	D	G	L1	L2	L3	SW1	e	g/Stk
G=Rohrgewinde (zylindrisch)		G=BSP thread (parallel)						G=rosca de conexión (cilíndrica)		
DRM-G 1.8	808.3100.020.30	500	17.0	1/8	42.5	10.0	8.0	17	4.0	60
DRM-G 1.4	808.3100.040.30	500	19.0	1/4	51.0	14.0	12.0	19	6.0	81
DRM-G 3.8	808.3100.060.30	400	24.0	3/8	60.0	14.0	12.0	24	7.5	181
DRM-G 1.2	808.3100.080.30	400	30.0	1/2	72.0	18.0	14.0	30	11.0	266
DRM-G 3.4	808.3100.120.30	250	36.0	3/4	84.0	20.0	16.0	36	14.0	450
DRM-G 1.1	808.3100.160.30	250	46.0	1	95.0	23.0	18.0	46	18.0	817
DRM-G 5.4	808.3100.180.30	250	50.0	1 1/4	110.0	25.0	20.0	50	24.0	920
DRM-G 3.2	808.3100.200.30	250	60.0	1 1/2	114.0	27.0	22.0	60	28.0	1436

50

Dichtung: FKM; EPDM, NBR, PTFE auf Anfrage.

Seal: FKM; EPDM, NBR, PTFE on request.

Junta: FKM; EPDM, NBR, PTFE bajo demanda.

Druckangaben basieren auf Kombination mit Stutzen der leichten Baureihe. In Verbindung mit Stutzen der schweren Baureihe sind höhere Nenndrücke möglich.

Pressure specifications are based on combination with light series connectors. Higher nominal pressures are possible in combination with heavy series connectors.

.Las especificaciones de presión se basan en la combinación con cuerpos roscados de series ligeras. Las presiones nominales más altas son posibles en combinación con cuerpos de series pesadas.

Öffnungsdruck 1 bar (Normalausführung). Abweichende Öffnungsdrücke werden auf Wunsch geliefert.

Opening pressure 1 bar (standard type). Additional pressure rates can be supplied on request.

Presión de apertura 1 bar (versión normal). Presiones de apertura diferentes bajo demanda.

e=kleinster Innen-Ø

e=minimum inside diameter

e=Ø interior mínimo

Rückschlagventile

beidseitig Rohranschluss, ohne Mutter und Schneidring

Non-return valves

double-sided tube connection, without nut and cutting ring

Válvulas de retención

conexión de tubos en los dos lados, sin tuerca y anillo cortante

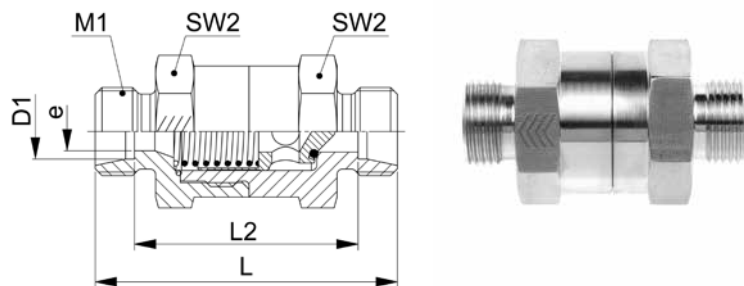

XDRV-..L/S

Type-D1	Mat.-Nr.	PN	M1	L	L2	SW2	e	g/Stk
XDRV-06L	806.3104.060.20	500	12x1.5	43.0	29.0	17	4.0	45
XDRV-08L	806.3104.080.20	500	14x1.5	44.0	30.0	19	6.0	56
XDRV-10L	806.3104.100.20	500	16x1.5	54.5	40.5	24	7.0	112
XDRV-12L	806.3104.120.20	400	18x1.5	57.5	43.5	30	11.0	166
XDRV-15L	806.3104.150.20	400	22x1.5	61.5	47.5	30	11.0	193
XDRV-18L	806.3104.180.20	400	26x1.5	66.5	51.5	36	14.0	319
XDRV-22L	806.3104.220.20	250	30x2.0	77.0	61.5	46	18.0	551
XDRV-28L	806.3104.280.20	250	36x2.0	84.5	69.0	50	24.0	672
XDRV-35L	806.3104.350.20	250	45x2.0	96.0	74.5	60	28.0	1144
XDRV-42L	806.3104.420.20	250	52x2.0	96.5	74.0	60	28.0	1205
XDRV-06S	806.3104.060.30	800	14x1.5	48.5	34.5	17	4.0	58
XDRV-08S	806.3104.080.30	800	16x1.5	48.5	34.5	19	6.0	69
XDRV-10S	806.3104.100.30	800	18x1.5	55.5	40.0	24	7.0	120
XDRV-12S	806.3104.120.30	630	20x1.5	57.5	42.5	30	11.0	170
XDRV-14S	806.3104.140.30	630	22x1.5	63.5	47.5	30	11.0	195
XDRV-16S	806.3104.160.30	630	24x1.5	67.5	50.5	30	11.0	222
XDRV-20S	806.3104.200.30	420	30x2.0	75.5	54.5	36	14.0	371
XDRV-25S	806.3104.250.30	420	36x2.0	82.5	58.0	46	18.0	605
XDRV-30S	806.3104.300.30	420	42x2.0	97.0	69.5	50	24.0	807
XDRV-38S	806.3104.380.30	420	52x2.0	107.5	75.0	60	28.0	1334

Dichtung: FKM; EPDM, NBR, PTFE auf Anfrage.

Seal: FKM; EPDM, NBR, PTFE on request.

Junta: FKM; EPDM, NBR, PTFE bajo demanda.

Öffnungsdruck 1 bar (Normalausführung).
Abweichende Öffnungsdrücke werden auf Wunsch geliefert.

Opening pressure 1 bar (standard type).
Additional pressure rates can be supplied on request.

Presión de apertura 1 bar (versión normal).
Presiones de apertura diferentes bajo demanda.

D1=Rohr außen-Ø
M1=metrisches Anschlußgewinde
e=kleinster Innen-Ø

D1=tube outside diameter
M1=metric connecting thread
e=minimum inside diameter

D1=Ø exterior del tubo
M1=rosca métrica conexión
e=Ø interior mínimo

Rückschlagventile

beidseitig Schneidringanschluss

Non-return valves

double-sided cutting ring connection

Válvulas de retención

conexión de anillo cortante en los dos lados

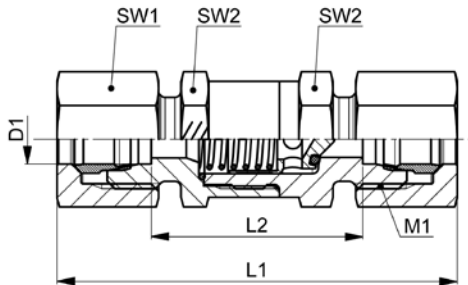

DRV-..L/S

Type-D1	Mat.-Nr.	PN	M1	L1	L2	SW1	SW2	g/Stk
DRV-06L	808.3104.060.20	500	12x1.5	59.0	29.0	14	17	71
DRV-08L	808.3104.080.20	500	14x1.5	60.0	30.0	17	19	103
DRV-10L	808.3104.100.20	500	16x1.5	71.0	40.5	19	24	152
DRV-12L	808.3104.120.20	400	18x1.5	73.5	43.5	22	30	230
DRV-15L	808.3104.150.20	400	22x1.5	77.5	47.5	27	30	278
DRV-18L	808.3104.180.20	400	26x1.5	84.5	51.5	32	36	412
DRV-22L	808.3104.220.20	250	30x2.0	95.0	61.5	36	46	598
DRV-28L	808.3104.280.20	250	36x2.0	102.5	69.0	41	50	970
DRV-35L	808.3104.350.20	250	45x2.0	118.0	74.5	50	60	1620
DRV-42L	808.3104.420.20	250	52x2.0	120.5	74.0	60	60	2880
DRV-06S	808.3104.060.30	800	14x1.5	64.5	34.5	17	17	117
DRV-08S	808.3104.080.30	800	16x1.5	64.5	34.5	19	19	132
DRV-10S	808.3104.100.30	800	18x1.5	73.5	40.0	22	24	174
DRV-12S	808.3104.120.30	630	20x1.5	75.5	42.5	24	30	211
DRV-14S	808.3104.140.30	630	22x1.5	83.5	47.5	27	30	307
DRV-16S	808.3104.160.30	630	24x1.5	87.5	50.5	30	30	415
DRV-20S	808.3104.200.30	420	30x2.0	97.0	54.5	36	36	600
DRV-25S	808.3104.250.30	420	36x2.0	106.5	58.0	46	46	962
DRV-30S	808.3104.300.30	420	42x2.0	123.0	69.5	50	50	1630
DRV-38S	808.3104.380.30	420	52x2.0	137.5	75.0	60	60	2380

Baumaße sind Ungefährmaße bei angezogener Überwurfmutter.

Sizes are approximate dimensions at tightened nut.

Las medidas son aproximadas con la tuerca de unión apretada.

Dichtung: FKM; EPDM, NBR, PTFE auf Anfrage.

Seal: FKM; EPDM, NBR, PTFE on request.

Junta: FKM; EPDM, NBR, PTFE bajo demanda.

Öffnungsdruck 1 bar (Normalausführung).
Abweichende Öffnungsdrücke werden auf Wunsch geliefert.

Opening pressure 1 bar (standard type).
Additional pressure rates can be supplied on request.

Presión de apertura 1 bar (versión normal).
Presiones de apertura diferentes bajo demanda.

D1=Rohraußen-Ø
M1=metrisches Anschlußgewinde

D1=tube outside diameter
M1=metric connecting thread

D1=Ø exterior del tubo
M1=rosca métrica conexión

Rückschlagventile mit Einschraubgewinde

Abdichtung durch Profildichtring Form E nach ISO 1179-2, Anströmseite Rohranschluss, ohne Mutter und Schneidring

Non-return valves with male adaptor thread

profile sealing ring form E acc. ISO 1179-2, inflow side at tube connection, without nut and cutting ring

Válvulas de retención con conexión de rosca

cierre hermético mediante junta con perfil forma E según ISO 1179-2, flujo de entrada en la conexión de tubo, sin tuerca y anillo cortante

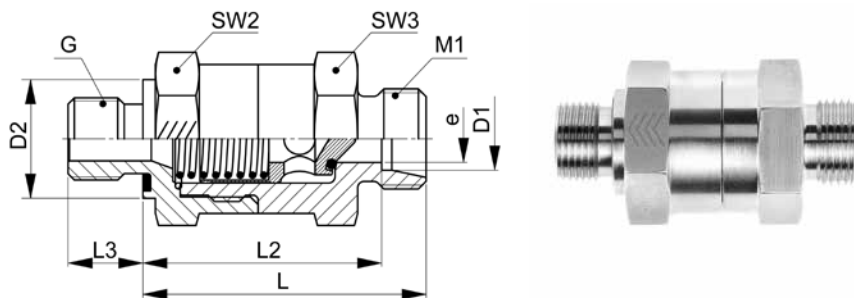

XERVZ-..LR WD/SR WD

Type-D1 G	Mat.-Nr.	PN	D2	G	M1	L	L2	L3	SW2	SW3	e	g/Stk
G=Rohrgewinde (zylindrisch)		G=BSP thread (parallel)					G=rosca de conexión (cilíndrica)					
XERVZ-06LR 1.8 WD	806.3111.100.20	500	14.0	1/8	12x1.5	35.0	28.0	8.0	17	17	4.0	46
XERVZ-08LR 1.4 WD	806.3111.170.20	500	19.0	1/4	14x1.5	36.5	29.5	12.0	19	19	6.0	62
XERVZ-10LR 1.4 WD	806.3111.270.20	500	19.0	1/4	16x1.5	45.5	38.5	12.0	24	24	7.0	108
XERVZ-12LR 3.8 WD	806.3111.390.20	400	22.0	3/8	18x1.5	49.0	42.0	12.0	30	30	11.0	171
XERVZ-15LR 1.2 WD	806.3111.534.20	400	27.0	1/2	22x1.5	52.0	45.0	14.0	30	30	11.0	206
XERVZ-18LR 1.2 WD	806.3111.646.20	400	27.0	1/2	26x1.5	57.5	50.0	14.0	36	36	14.0	320
XERVZ-22LR 3.4 WD	806.3111.768.20	250	32.0	3/4	30x2.0	62.5	55.0	16.0	46	46	18.0	521
XERVZ-28LR 1.1 WD	806.3111.850.20	250	40.0	1	36x2.0	70.5	63.0	18.0	50	50	24.0	644
XERVZ-35LR 5.4 WD	806.3111.944.20	250	50.0	1 1/4	45x2.0	79.5	69.0	20.0	60	60	28.0	1138
XERVZ-42LR 3.2 WD	806.3111.992.20	250	55.0	1 1/2	52x2.0	79.5	68.5	22.0	60	60	28.0	1257
XERVZ-06SR 1.4 WD	806.3111.110.30	800	19.0	1/4	14x1.5	38.5	31.5	12.0	19	17	4.0	64
XERVZ-08SR 1.4 WD	806.3111.170.30	800	19.0	1/4	16x1.5	38.5	31.5	12.0	19	19	6.0	68
XERVZ-10SR 3.8 WD	806.3111.280.30	800	22.0	3/8	18x1.5	45.5	38.0	12.0	24	24	7.0	124
XERVZ-12SR 3.8 WD	806.3111.390.30	630	22.0	3/8	20x1.5	49.0	41.5	12.0	30	30	11.0	173
XERVZ-14SR 1.2 WD	806.3111.504.30	630	27.0	1/2	22x1.5	52.5	44.5	14.0	30	30	11.0	204
XERVZ-16SR 1.2 WD	806.3111.566.30	630	27.0	1/2	24x1.5	55.0	46.5	14.0	30	30	11.0	220
XERVZ-20SR 3.4 WD	806.3111.704.30	420	32.0	3/4	30x2.0	62.5	52.0	16.0	36	36	14.0	382
XERVZ-25SR 1.1 WD	806.3111.810.30	420	40.0	1	36x2.0	66.5	54.5	18.0	46	46	18.0	616
XERVZ-30SR 5.4 WD	806.3111.902.30	420	50.0	1 1/4	42x2.0	77.5	64.0	20.0	50	50	24.0	834
XERVZ-38SR 3.2 WD	806.3111.953.30	420	55.0	1 1/2	52x2.0	85.5	69.5	22.0	60	60	28.0	1330

Dichtung: FKM; EPDM, NBR, PTFE auf Anfrage.

Seal: FKM; EPDM, NBR, PTFE on request.

Junta: FKM; EPDM, NBR, PTFE bajo demanda.

Öffnungsdruck 1 bar (Normalausführung).
Abweichende Öffnungsdrücke werden auf Wunsch geliefert.

Opening pressure 1 bar (standard type).
Additional pressure rates can be supplied on request.

Presión de apertura 1 bar (versión normal).
Presiones de apertura diferentes bajo demanda.

D1=Rohraußen-Ø
M1=metrisches Anschlußgewinde
e=kleinster Innen-Ø

D1=tube outside diameter
M1=metric connecting thread
e=minimum inside diameter

D1=Ø exterior del tubo
M1=rosca métrica conexión
e=Ø interior mínimo

Rückschlagventile mit Einschraubgewinde

Abdichtung durch Profildichtring Form E nach ISO 1179-2, einseitig Schneidringanschluss, Anströmseite Rohranschluss

Non-return valves with male adaptor thread

profile sealing ring form E acc. ISO 1179-2, with cutting ring connection on one side, inflow side at tube connection

Válvulas de retención con conexión de rosca

cierre hermético mediante junta con perfil forma E según ISO 1179-2, conexión de anillo cortante en un lado, flujo de entrada en la conexión de tubo

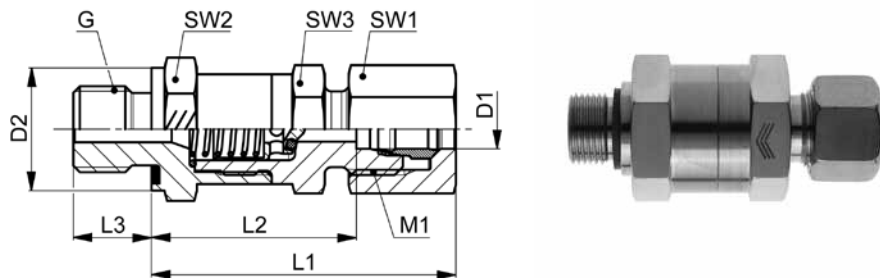

ERVZ-..LR WD/SR WD

Type-D1 G	Mat.-Nr.	PN	D2	G	M1	L1	L2	L3	SW1	SW2	SW3	g/Stk
G=Rohrgewinde (zylindrisch)		G=BSP thread (parallel)			G=rosca de conexión (cilíndrica)							
ERVZ-06LR 1.8 WD	808.3111.100.20	500	14.0	1/8	12x1.5	43.0	28.0	8.0	14	17	17	59
ERVZ-08LR 1.4 WD	808.3111.170.20	500	19.0	1/4	14x1.5	44.5	29.5	12.0	17	19	19	81
ERVZ-10LR 1.4 WD	808.3111.270.20	500	19.0	1/4	16x1.5	53.5	38.5	12.0	19	24	24	152
ERVZ-12LR 3.8 WD	808.3111.390.20	400	22.0	3/8	18x1.5	57.0	42.0	12.0	22	30	30	203
ERVZ-15LR 1.2 WD	808.3111.534.20	400	27.0	1/2	22x1.5	60.0	45.0	14.0	27	30	30	246
ERVZ-18LR 1.2 WD	808.3111.646.20	400	27.0	1/2	26x1.5	66.5	50.0	14.0	32	36	36	358
ERVZ-22LR 3.4 WD	808.3111.768.20	250	32.0	3/4	30x2.0	71.5	55.0	16.0	36	46	46	612
ERVZ-28LR 1.1 WD	808.3111.850.20	250	40.0	1	36x2.0	79.5	63.0	18.0	41	50	50	743
ERVZ-35LR 5.4 WD	808.3111.944.20	250	50.0	1 1/4	45x2.0	90.5	69.0	20.0	50	60	60	1444
ERVZ-42LR 3.2 WD	808.3111.992.20	250	55.0	1 1/2	52x2.0	91.5	68.5	22.0	60	60	60	1600
ERVZ-06SR 1.4 WD	808.3111.110.30	800	19.0	1/4	14x1.5	46.5	31.5	12.0	17	19	17	91
ERVZ-08SR 1.4 WD	808.3111.170.30	800	19.0	1/4	16x1.5	46.5	31.5	12.0	19	19	19	97
ERVZ-10SR 3.8 WD	808.3111.280.30	800	22.0	3/8	18x1.5	54.5	38.0	12.0	22	24	24	91
ERVZ-12SR 3.8 WD	808.3111.390.30	630	22.0	3/8	20x1.5	58.0	41.5	12.0	24	30	30	192
ERVZ-14SR 1.2 WD	808.3111.504.30	630	27.0	1/2	22x1.5	62.5	44.5	14.0	27	30	30	269
ERVZ-16SR 1.2 WD	808.3111.566.30	630	27.0	1/2	24x1.5	65.0	46.5	14.0	30	30	30	359
ERVZ-20SR 3.4 WD	808.3111.704.30	420	32.0	3/4	30x2.0	73.5	52.0	16.0	36	36	36	636
ERVZ-25SR 1.1 WD	808.3111.810.30	420	40.0	1	36x2.0	78.5	54.5	18.0	46	46	46	850
ERVZ-30SR 5.4 WD	808.3111.902.30	420	50.0	1 1/4	42x2.0	90.5	64.0	20.0	50	50	50	1406
ERVZ-38SR 3.2 WD	808.3111.953.30	420	55.0	1 1/2	52x2.0	100.5	69.5	22.0	60	60	60	1950

Baumaße sind Ungefährmaße bei angezogener Überwurfmutter.

Sizes are approximate dimensions at tightened nut.

Las medidas son aproximadas con la tuerca de unión apretada.

Dichtung: FKM; EPDM, NBR, PTFE auf Anfrage.

Seal: FKM; EPDM, NBR, PTFE on request.

Junta: FKM; EPDM, NBR, PTFE bajo demanda.

Öffnungsdruck 1 bar (Normalausführung).
Abweichende Öffnungsdrücke werden auf Wunsch geliefert.

Opening pressure 1 bar (standard type).
Additional pressure rates can be supplied on request.

Presión de apertura 1 bar (versión normal).
Presiones de apertura diferentes bajo demanda.

D1=Rohraußen-Ø
M1=metrisches Anschlußgewinde

D1=tube outside diameter
M1=metric connecting thread

D1=Ø exterior del tubo
M1=rosca métrica conexión

Rückschlagventile mit Einschraubgewinde

Abdichtung durch Profildichtring Form E nach ISO 1179-2, Anströmseite Einschraubgewinde, ohne Mutter und Schneidring

Non-return valves with male adaptor thread

profile sealing ring form E acc. ISO 1179-2, inflow side at male adaptor thread, without nut and cutting ring

Válvulas de retención con conexión de rosca

cierre hermético mediante junta con perfil forma E según ISO 1179-2, flujo de entrada en la conexión de rosca, sin tuerca y anillo cortante

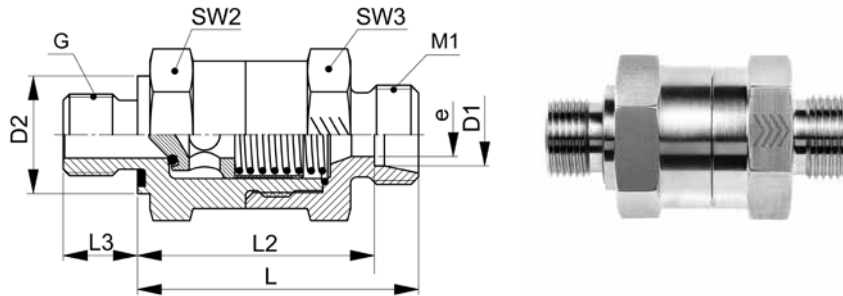

XERVV-..LR WD/SR WD

Type-D1 G	Mat.-Nr.	PN	D2	G	M1	L	L2	L3	SW2	SW3	e	g/Stk	
G=Rohrgewinde (zylindrisch)		G=BSP thread (parallel)					G=rosca de conexión (cilíndrica)						
XERVV-06LR 1.8 WD	806.3107.100.20	500	14.0	1/8	12x1.5	33.5	26.5	8.0	17	17	4.0	43	
XERVV-08LR 1.4 WD	806.3107.170.20	500	19.0	1/4	14x1.5	35.5	28.5	12.0	19	19	6.0	60	
XERVV-10LR 1.4 WD	806.3107.270.20	500	19.0	1/4	16x1.5	35.5	28.5	12.0	24	24	6.0	60	
XERVV-12LR 3.8 WD	806.3107.390.20	400	22.0	3/8	18x1.5	47.5	40.5	12.0	30	30	11.0	165	
XERVV-15LR 1.2 WD	806.3107.534.20	400	27.0	1/2	22x1.5	49.5	42.5	14.0	30	30	11.0	195	
XERVV-18LR 1.2 WD	806.3107.646.20	400	27.0	1/2	26x1.5	50.5	48.0	14.0	36	36	14.0	304	
XERVV-22LR 3.4 WD	806.3107.768.20	250	32.0	3/4	30x2.0	63.5	56.0	16.0	46	46	18.0	530	
XERVV-28LR 1.1 WD	806.3107.850.20	250	40.0	1	36x2.0	71.5	64.0	18.0	50	50	24.0	679	
XERVV-35LR 5.4 WD	806.3107.944.20	250	50.0	1 1/4	45x2.0	80.5	70.0	20.0	60	60	28.0	1160	
XERVV-42LR 3.2 WD	806.3107.992.20	250	55.0	1 1/2	52x2.0	81.5	70.5	22.0	60	60	28.0	1263	
XERVV-06SR 1.4 WD	806.3107.110.30	800	19.0	1/4	14x1.5	38.5	31.5	12.0	19	17	4.0	64	
XERVV-08SR 1.4 WD	806.3107.170.30	800	19.0	1/4	16x1.5	38.0	31.0	12.0	19	19	6.0	67	
XERVV-10SR 3.8 WD	806.3107.280.30	800	22.0	3/8	18x1.5	45.5	38.0	12.0	24	24	7.0	123	
XERVV-12SR 3.8 WD	806.3107.390.30	630	22.0	3/8	20x1.5	47.5	40.0	12.0	30	30	11.0	166	
XERVV-14SR 1.2 WD	806.3107.504.30	630	27.0	1/2	22x1.5	51.0	43.0	14.0	30	30	11.0	197	
XERVV-16SR 1.2 WD	806.3107.566.30	630	27.0	1/2	24x1.5	52.5	44.0	14.0	30	30	11.0	208	
XERVV-20SR 3.4 WD	806.3107.704.30	420	32.0	3/4	30x2.0	60.5	50.0	16.0	36	36	14.0	366	
XERVV-25SR 1.1 WD	806.3107.810.30	420	40.0	1	36x2.0	66.5	54.5	18.0	46	46	18.0	613	
XERVV-30SR 5.4 WD	806.3107.902.30	420	50.0	1 1/4	42x2.0	77.5	64.0	20.0	50	50	24.0	835	
XERVV-38SR 3.2 WD	806.3107.953.30	420	55.0	1 1/2	52x2.0	87.5	71.5	22.0	60	60	28.0	1375	

Dichtung: FKM; EPDM, NBR, PTFE auf Anfrage.

Seal: FKM; EPDM, NBR, PTFE on request.

Junta: FKM; EPDM, NBR, PTFE bajo demanda.

Öffnungsdruck 1 bar (Normalausführung).
Abweichende Öffnungsdrücke werden auf Wunsch geliefert.

Opening pressure 1 bar (standard type).
Additional pressure rates can be supplied on request.

Presión de apertura 1 bar (versión normal).
Presiones de apertura diferentes bajo demanda.

D1=Rohr außen-Ø
M1=metrisches Anschlußgewinde
e=kleinster Innen-Ø

D1=tube outside diameter
M1=metric connecting thread
e=minimum inside diameter

D1=Ø exterior del tubo
M1=rosca métrica conexión
e=Ø interior mínimo

Rückschlagventile mit Einschraubgewinde

Abdichtung durch Profildichtring Form E nach ISO 1179-2, einseitig Schneidringanschluss, Anströmseite Einschraubgewinde

Non-return valves with male adaptor thread

profile sealing ring form E acc. ISO 1179-2, with cutting ring connection on one side, inflow side at male adaptor thread

Válvulas de retención con conexión de rosca

cierre hermético mediante junta con perfil forma E según ISO 1179-2, conexión de anillo cortante en un lado, flujo de entrada en la conexión de rosca

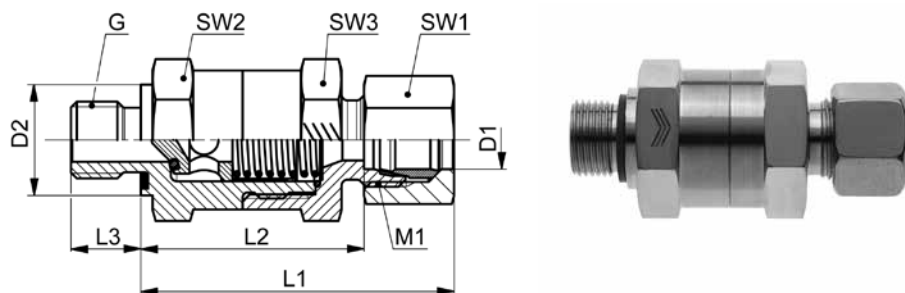

ERVV-..LR WD/SR WD

Type-D1 G	Mat.-Nr.	PN	D2	G	M1	L1	L2	L3	SW1	SW2	SW3	g/Stk
G=Rohrgewinde (zylindrisch)		G=BSP thread (parallel)			G=rosca de conexión (cilíndrica)							
ERVV-06LR 1.8 WD	808.3107.100.20	500	14.0	1/8	12x1.5	41.5	26.5	8.0	14	17	17	59
ERVV-08LR 1.4 WD	808.3107.170.20	500	19.0	1/4	14x1.5	43.5	28.5	12.0	17	19	19	81
ERVV-10LR 1.4 WD	808.3107.270.20	500	19.0	1/4	16x1.5	43.5	28.5	12.0	19	24	24	125
ERVV-12LR 3.8 WD	808.3107.390.20	400	22.0	3/8	18x1.5	55.5	40.5	12.0	22	30	30	203
ERVV-15LR 1.2 WD	808.3107.534.20	400	27.0	1/2	22x1.5	57.5	42.5	14.0	27	30	30	246
ERVV-18LR 1.2 WD	808.3107.646.20	400	27.0	1/2	26x1.5	59.5	48.0	14.0	32	36	36	358
ERVV-22LR 3.4 WD	808.3107.768.20	250	32.0	3/4	30x2.0	72.5	56.0	16.0	36	46	46	527
ERVV-28LR 1.1 WD	808.3107.850.20	250	40.0	1	36x2.0	80.5	64.0	18.0	41	50	50	794
ERVV-35LR 5.4 WD	808.3107.944.20	250	50.0	1 1/4	45x2.0	91.5	70.0	20.0	50	60	60	1444
ERVV-42LR 3.2 WD	808.3107.992.20	250	55.0	1 1/2	52x2.0	93.5	70.5	22.0	60	60	60	1516
ERVV-06SR 1.4 WD	808.3107.110.30	800	19.0	1/4	14x1.5	46.5	31.5	12.0	17	19	17	91
ERVV-08SR 1.4 WD	808.3107.170.30	800	19.0	1/4	16x1.5	46.0	31.0	12.0	19	19	19	97
ERVV-10SR 3.8 WD	808.3107.280.30	800	22.0	3/8	18x1.5	54.5	38.0	12.0	22	24	24	159
ERVV-12SR 3.8 WD	808.3107.390.30	630	22.0	3/8	20x1.5	56.5	40.0	12.0	24	30	30	192
ERVV-14SR 1.2 WD	808.3107.504.30	630	27.0	1/2	22x1.5	62.0	43.0	14.0	27	30	30	269
ERVV-16SR 1.2 WD	808.3107.566.30	630	27.0	1/2	24x1.5	62.5	44.0	14.0	30	30	30	359
ERVV-20SR 3.4 WD	808.3107.704.30	420	32.0	3/4	30x2.0	71.5	50.0	16.0	36	36	36	636
ERVV-25SR 1.1 WD	808.3107.810.30	420	40.0	1	36x2.0	78.5	54.5	18.0	46	46	46	856
ERVV-30SR 5.4 WD	808.3107.902.30	420	50.0	1 1/4	42x2.0	90.5	64.0	20.0	50	50	50	1406
ERVV-38SR 3.2 WD	808.3107.953.30	420	55.0	1 1/2	52x2.0	102.5	71.5	22.0	60	60	60	1950

Baumaße sind Ungefährmaße bei angezogener Überwurfmutter.

Sizes are approximate dimensions at tightened nut.

Las medidas son aproximadas con la tuerca de unión apretada.

Dichtung: FKM; EPDM, NBR, PTFE auf Anfrage.

Seal: FKM; EPDM, NBR, PTFE on request.

Junta: FKM; EPDM, NBR, PTFE bajo demanda.

Öffnungsdruck 1 bar (Normalausführung).
Abweichende Öffnungsdrücke werden auf Wunsch geliefert.

Opening pressure 1 bar (standard type).
Additional pressure rates can be supplied on request.

Presión de apertura 1 bar (versión normal).
Presiones de apertura diferentes bajo demanda.

D1=Rohr außen-Ø
M1=metrisches Anschlußgewinde

D1=tube outside diameter
M1=metric connecting thread

D1=Ø exterior del tubo
M1=rosca métrica conexión

Rückschlagventile

beidseitig Klemmringanschluss

Non-return valves

double-sided clamping ring connection

Válvulas de retención

conexión de anillo de apriete NC en los dos lados

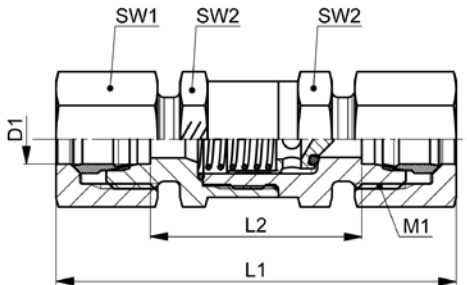

NC-DRV-..L/S

Type-D1	Mat.-Nr.	PN	M1	L1	L2	SW1	SW2	g/Stk
NC-DRV-06L	818.3104.060.20	250	12x1.5	61.0	29.0	14	17	71
NC-DRV-08L	818.3104.080.20	250	14x1.5	62.0	30.0	17	19	103
NC-DRV-10L	818.3104.100.20	250	16x1.5	75.0	40.5	19	24	152
NC-DRV-12L	818.3104.120.20	250	18x1.5	76.5	43.5	22	30	230
NC-DRV-15L	818.3104.150.20	250	22x1.5	81.5	47.5	27	30	278
NC-DRV-18L	818.3104.180.20	160	26x1.5	85.5	51.5	32	36	412
NC-DRV-22L	818.3104.220.20	160	30x2.0	101.0	61.5	36	46	598
NC-DRV-06S	818.3104.060.30	400	14x1.5	66.5	34.5	17	17	117
NC-DRV-08S	818.3104.080.30	400	16x1.5	66.5	34.5	19	19	132
NC-DRV-10S	818.3104.100.30	400	18x1.5	77.5	40.0	22	24	174
NC-DRV-12S	818.3104.120.30	400	20x1.5	80.5	42.5	24	30	211
NC-DRV-14S	818.3104.140.30	315	22x1.5	88.5	47.5	30	30	307
NC-DRV-16S	818.3104.160.30	315	24x1.5	93.5	50.5	30	30	415
NC-DRV-20S	818.3104.200.30	250	30x2.0	104.5	54.5	36	36	600
NC-DRV-25S	818.3104.250.30	250	36x2.0	112.5	58.0	46	46	962

Baumaße sind Ungefährmaße bei angezogener Überwurfmutter.

Sizes are approximate dimensions at tightened nut.

Las medidas son aproximadas con la tuerca de unión apretada.

Dichtung: FKM; EPDM, NBR, PTFE auf Anfrage.

Seal: FKM; EPDM, NBR, PTFE on request.

Junta: FKM; EPDM, NBR, PTFE bajo demanda.

Öffnungsdruck 1 bar (Normalausführung).
Abweichende Öffnungsdrücke werden auf Wunsch geliefert.

Opening pressure 1 bar (standard type).
Additional pressure rates can be supplied on request.

Presión de apertura 1 bar (versión normal).
Presiones de apertura diferentes bajo demanda.

D1=Rohraußen-Ø
M1=metrisches Anschlußgewinde

D1=tube outside diameter
M1=metric connecting thread

D1=Ø exterior del tubo
M1=rosca métrica conexión

Rückschlagventile mit Einschraubgewinde

Abdichtung durch Profildichtring Form E nach ISO 1179-2, einseitig Klemmringanschluss, Anströmseite Rohranschluss

Non-return valves with male adaptor thread

profile sealing ring form E acc. ISO 1179-2, with clamping ring connection on one side, inflow side at tube connection

Válvulas de retención con conexión de rosca

cierre hermético mediante junta con perfil forma E según ISO 1179-2, conexión de anillo de apriete NC en un lado, flujo de entrada en la conexión de tubo

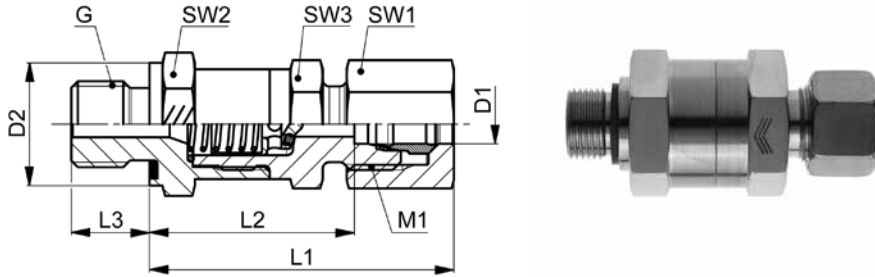

NC-ERVZ-..LR WD/SR WD

Type-D1 G	Mat.-Nr.	PN	D2	G	M1	L1	L2	L3	SW1	SW2	SW3	g/Stk
G=Rohrgewinde (zylindrisch)	G=BSP thread (parallel)	G=rosca de conexión (cilíndrica)										
NC-ERVZ-06LR 1.8 WD	818.3111.100.20	250	14.0	1/8	12x1.5	44.0	28.0	8.0	14	17	17	59
NC-ERVZ-08LR 1.4 WD	818.3111.170.20	250	19.0	1/4	14x1.5	45.5	29.5	12.0	17	19	19	81
NC-ERVZ-10LR 1.4 WD	818.3111.270.20	250	19.0	1/4	16x1.5	55.5	38.5	12.0	19	24	24	152
NC-ERVZ-12LR 3.8 WD	818.3111.390.20	250	22.0	3/8	18x1.5	58.5	42.0	12.0	22	30	30	203
NC-ERVZ-15LR 1.2 WD	818.3111.534.20	250	27.0	1/2	22x1.5	62.0	45.0	14.0	27	30	30	246
NC-ERVZ-18LR 1.2 WD	818.3111.646.20	160	27.0	1/2	26x1.5	67.0	50.0	14.0	32	36	36	358
NC-ERVZ-22LR 3.4 WD	818.3111.768.20	160	32.0	3/4	30x2.0	74.5	55.5	16.0	36	46	46	612
NC-ERVZ-06SR 1.4 WD	818.3111.110.30	400	19.0	1/4	14x1.5	47.5	31.5	12.0	17	19	17	91
NC-ERVZ-08SR 1.4 WD	818.3111.170.30	400	19.0	1/4	16x1.5	47.5	31.5	12.0	19	19	19	97
NC-ERVZ-10SR 3.8 WD	818.3111.280.30	400	22.0	3/8	18x1.5	56.5	38.0	12.0	22	24	24	159
NC-ERVZ-12SR 3.8 WD	818.3111.390.30	400	22.0	3/8	20x1.5	60.5	41.5	12.0	24	30	30	192
NC-ERVZ-14SR 1.2 WD	818.3111.504.30	315	27.0	1/2	22x1.5	65.0	44.5	14.0	27	30	30	269
NC-ERVZ-16SR 1.2 WD	818.3111.566.30	315	27.0	1/2	24x1.5	68.0	46.5	14.0	30	30	30	359
NC-ERVZ-20SR 3.4 WD	818.3111.704.30	250	32.0	3/4	30x2.0	77.0	52.0	16.0	36	36	36	636
NC-ERVZ-25SR 1.1 WD	818.3111.810.30	250	40.0	1	36x2.0	81.5	54.5	18.0	46	46	46	856

Baumaße sind Ungefährmaße bei angezogener Überwurfmutter.

Sizes are approximate dimensions at tightened nut.

Las medidas son aproximadas con la tuerca de unión apretada.

Dichtung: FKM; EPDM, NBR, PTFE auf Anfrage.

Seal: FKM; EPDM, NBR, PTFE on request.

Junta: FKM; EPDM, NBR, PTFE bajo demanda.

Öffnungsdruck 1 bar (Normalausführung).
Abweichende Öffnungsdrücke werden auf Wunsch geliefert.

Opening pressure 1 bar (standard type).
Additional pressure rates can be supplied on request.

Presión de apertura 1 bar (versión normal).
Presiones de apertura diferentes bajo demanda.

Rückschlagventile mit Einschraubgewinde

Abdichtung durch Profildichtring Form E nach ISO 1179-2, einseitig Klemmringanschluss, Anströmseite Einschraubgewinde

Non-return valves with male adaptor thread

profile sealing ring form E acc. ISO 1179-2, with clamping ring connection on one side, inflow side at male adaptor thread

Válvulas de retención con conexión de rosca

cierre hermético mediante junta con perfil forma E según ISO 1179-2, conexión de anillo de apriete NC en un lado, flujo de entrada en la conexión de rosca

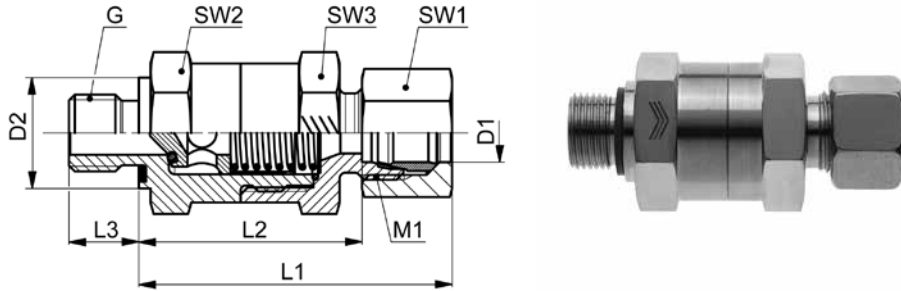

NC-ERVV-..LR WD/SR WD

Type-D1 G	Mat.-Nr.	PN	D2	G	M1	L1	L2	L3	SW1	SW2	SW3	g/Stk
G=Rohrgewinde (zylindrisch)		G=BSP thread (parallel)					G=rosca de conexión (cilíndrica)					
NC-ERVV-06LR 1.8 WD	818.3107.100.20	250	14.0	1/8	12x1.5	42.5	26.5	8.0	14	17	17	59
NC-ERVV-08LR 1.4 WD	818.3107.170.20	250	19.0	1/4	14x1.5	44.5	28.5	12.0	17	19	19	81
NC-ERVV-10LR 1.4 WD	818.3107.270.20	250	19.0	1/4	16x1.5	45.5	28.5	12.0	19	24	24	125
NC-ERVV-12LR 3.8 WD	818.3107.390.20	250	22.0	3/8	18x1.5	57.0	40.5	12.0	22	30	30	203
NC-ERVV-15LR 1.2 WD	818.3107.534.20	250	27.0	1/2	22x1.5	59.5	42.5	14.0	27	30	30	246
NC-ERVV-18LR 1.2 WD	818.3107.646.20	160	27.0	1/2	26x1.5	60.0	48.0	14.0	32	36	36	358
NC-ERVV-22LR 3.4 WD	818.3107.768.20	160	32.0	3/4	30x2.0	75.5	56.0	16.0	36	46	46	527
NC-ERVV-06SR 1.4 WD	818.3107.110.30	400	19.0	1/4	14x1.5	47.5	31.5	12.0	17	19	17	91
NC-ERVV-08SR 1.4 WD	818.3107.170.30	400	19.0	1/4	16x1.5	47.0	31.0	12.0	19	19	19	97
NC-ERVV-10SR 3.8 WD	818.3107.280.30	400	22.0	3/8	18x1.5	56.5	38.0	12.0	22	24	24	159
NC-ERVV-12SR 3.8 WD	818.3107.390.30	400	22.0	3/8	20x1.5	59.0	40.0	12.0	24	30	30	192
NC-ERVV-14SR 1.2 WD	818.3107.504.30	315	27.0	1/2	22x1.5	64.5	43.0	14.0	27	30	30	269
NC-ERVV-16SR 1.2 WD	818.3107.566.30	315	27.0	1/2	24x1.5	65.5	44.0	14.0	30	30	30	359
NC-ERVV-20SR 3.4 WD	818.3107.704.30	250	32.0	3/4	30x2.0	75.0	50.0	16.0	36	36	36	636
NC-ERVV-25SR 1.1 WD	818.3107.810.30	250	40.0	1	36x2.0	81.5	54.5	18.0	46	46	46	856

Baumaße sind Ungefährmaße bei angezogener Überwurfmutter.

Sizes are approximate dimensions at tightened nut.

Las medidas son aproximadas con la tuerca de unión apretada.

Dichtung: FKM; EPDM, NBR, PTFE auf Anfrage.

Seal: FKM; EPDM, NBR, PTFE on request.

Junta: FKM; EPDM, NBR, PTFE bajo demanda.

Öffnungsdruck 1 bar (Normalausführung).
Abweichende Öffnungsdrücke werden auf Wunsch geliefert.

Opening pressure 1 bar (standard type).
Additional pressure rates can be supplied on request.

Presión de apertura 1 bar (versión normal).
Presiones de apertura diferentes bajo demanda.

D1=Rohraußen-Ø
M1=metrisches Anschlußgewinde

D1=tube outside diameter
M1=metric connecting thread

D1=Ø exterior del tubo
M1=rosca métrica conexión

Technische Informationen

Technical Information

Información Técnica

**Hochdruck-Absperrventil
Typ AVD**

durchgeschmiedete Form, Kopfstück eingeschraubt

**High pressure needle valve
Type AVD**

forged form, screwed in bonnet

**Válvula de cierre de alta presión
Tipo AVD**

Forma forjada, cabeza enroscado

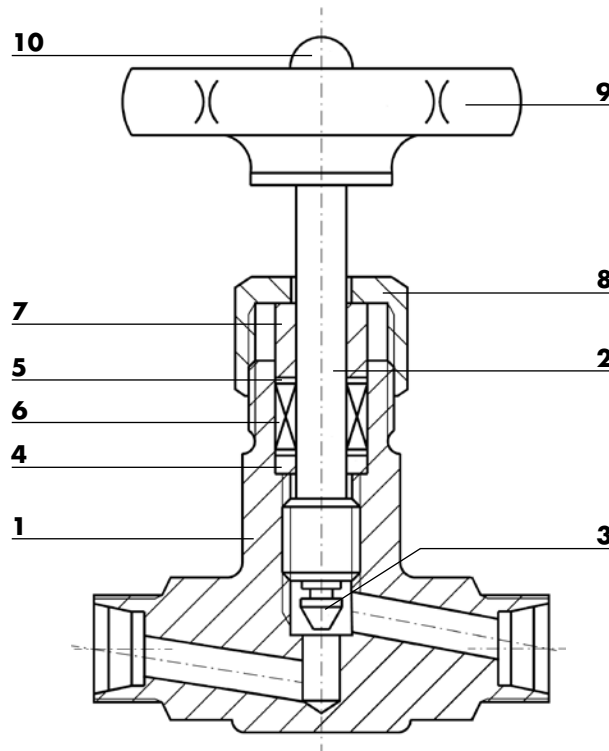

	Bauteil Part Componente	Werkstoff Material Material		Bauteil Part Componente	Werkstoff Material Material
1	Gehäuse Body Carcasa	Edelstahl 1.4571 / AISI 316 Ti Stainless steel 1.4571 / AISI 316 Ti Acero inoxidable 1.4571 / AISI 316 Ti	6	Packung Gland packing Empaquetadura	PTFE oder Reingraphit PTFE or Graphite PTFE o Grafito
2	Spindel Stem Husillo	Edelstahl 1.4571 / AISI 316 Ti Stainless steel 1.4571 / AISI 316 Ti Acero inoxidable 1.4571 / AISI 316 Ti	7	Stopfbuchse Gland Prensaestopa	Edelstahl 1.4571 / AISI 316 Ti Stainless steel 1.4571 / AISI 316 Ti Acero inoxidable 1.4571 / AISI 316 Ti
3	Dichtkegel Taper Junta cónica	Edelstahl 1.4571 / AISI 316 Ti Stainless steel 1.4571 / AISI 316 Ti Acero inoxidable 1.4571 / AISI 316 Ti	8	Überwurfmutter Nut Tuerca	Edelstahl 1.4571 / AISI 316 Ti Stainless steel 1.4571 / AISI 316 Ti Acero inoxidable 1.4571 / AISI 316 Ti
4	Grundring Bottom ring Anillo de fondo	Edelstahl 1.4571 / AISI 316 Ti Stainless steel 1.4571 / AISI 316 Ti Acero inoxidable 1.4571 / AISI 316 Ti	9	Handrad Hand wheel Volante	Stahlblech Steel plate Chapa de acero
5	Abstreifring Scraper ring Anillo despojarse	Novapress Novapress Novapress	10	Sechskantmutter Hexagon nut Tuerca hexágona	Edelstahl 1.4301 / AISI 304 Stainless steel 1.4301 / AISI 304 Acero inoxidable 1.4301 / AISI 304

Kugelhähne, Ventile

Ball valves, Valves

Llaves esféricas, Válvulas

Konstruktionsaufbau

Alle EXMAR Ventilgehäuse sind aus Edelstahl Werkstoff 1.4571/AISI 316 Ti geschmiedet. Eine anschließende Wärmebehandlung garantiert ein optimales Materialgefüge.

Diese Ventile haben ein innenliegendes Spindelgewinde. Die großzügig dimensionierte Spindel ist feinstbearbeitet und garantiert somit eine leichte Betätigung bei geringstem Verschleiß der Stopfbuchsenpackung.

Durch die 2-teilige Spindel wird eine sichere Abdichtung bei dünnflüssigen Medien gewährleistet.

Bei allen Ausführungen ist der Kegel in die Spindel "ingerollt", so dass der Kegel drehbar, aber selbstzentrierend und unlösbar ist.

Prüfungen

EXMAR Ventile werden auf Gehäusefestigkeit und Dichtheit geprüft. Hierbei gelten die Anforderungen nach DIN EN 12266-1.

Zeugnisse

Auf Wunsch werden Werksbescheinigungen oder Werkzeugeugnisse nach DIN EN 10204 erstellt.

Druck-Temperatur-Diagramm

Hochdruck-Absperrventil Typ AVD
PTFE

Design

All EXMAR valve bodies are forged from stainless steel material 1.4571/AISI 316 Ti. A final heat treatment guarantees optimum material structure.

These valves are built with an internal thread stem. The generously dimensioned stem is micro-machined and this guarantees smooth operation with very low wear of the gland packing.

The 2-parts stem ensures a secure sealing with highly fluid media.

In all versions the taper is "rolled into" the spindle so that the taper is rotatable but self-centering and non-detachable.

Tests

EXMAR valves are tested for the using stability and tightness. The requirements are specified in DIN EN 12266-1.

Certificates

Certificates of conformity or certificates of compliance in accordance with DIN EN 10204 will be provided upon request.

Pressure-Temperature-Diagram

High pressure needle valve Type AVD
PTFE

Diseño constructivo

Todos los cuerpos de válvulas EXMAR están forjados de acero inoxidable 1.4571/AIS 316 Ti. El tratamiento térmico siguiente garantiza una estructura óptima del material.

Las válvulas tienen una rosca de husillo interior. El husillo sobredimensionado está superacabado y garantiza facilidad de accionamiento con mínimo desgaste de la empaquetadura para prensaestopas.

El husillo de dos piezas garantiza una hermetización segura para medios líquidos.

En todas las versiones, el cono está "enrollado" dentro del husillo: aunque puede girar, es autocentrante y no extraíble.

Verificaciones

Las válvulas EXMAR son comprobadas en relación con la resistencia del cuerpo y la estanquidad. Se aplican los requisitos según DIN EN 12266-1.

Certificados

Bajo demanda se entregarán certificados de fábrica o de material según DIN EN 10204.

Diagrama de presión y temperatura

Válvula de cierre de alta presión Tipo AVD
PTFE

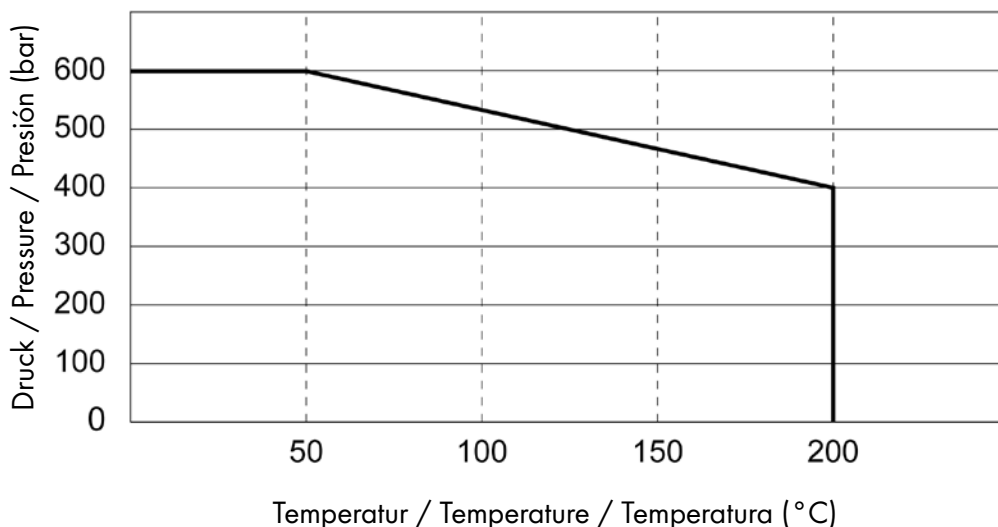

Anmerkung:

Der maximal mögliche Betriebsdruck PN kann auf Grund der Anschlüsse unter dem als maximal angegebenen Nenndruck PN liegen. Sicherheitsfaktor: 1.5-fach

Remark:

Due to the connectors, the maximum possible working pressure PN can be lower than the maximum nominal pressure PN specified. Safety factor: 1.5 times

Nota:

Por cuestiones relacionadas con las conexiones, la presión de servicio máxima PN puede ser menor que la presión nominal PN señalada. Factor de seguridad: 1.5 veces

Hochdruck-Absperrventile

beidseitig Innengewinde

High pressure needle valves

double-sided female thread

Válvulas de cierre de alta presión

rosca interior en los dos lados

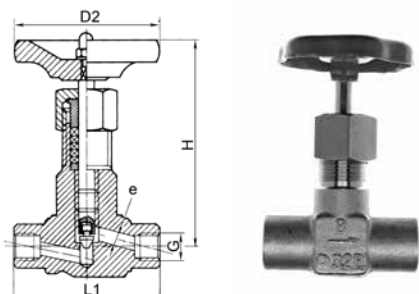

AVD-G

Type-G	Mat.-Nr.	PN	D2	G	H	L1	e	g/Stk
G=Rohrgewinde (zylindrisch)		G=BSP thread (parallel)						G=rosca de conexión (cilíndrica)
AVD-G 1.8	808.7004.020	400	70.0	1/8	85.0	65.0	4.0	350
AVD-G 1.4	808.7004.040	400	70.0	1/4	85.0	65.0	4.0	406
AVD-G 3.8	808.7004.060	400	70.0	3/8	85.0	65.0	6.0	386

Gewinde nach ISO 228/1

thread to ISO 228/1

rosca según ISO 228/1

e=kleinster Innen-Ø

e=minimum inside diameter

e=Ø interior mínimo

Hochdruck-Absperrventile

beidseitig Rohranschluss, ohne Mutter und Schneidring

High pressure needle valves

double-sided tube connection, without nut and cutting ring

Válvulas de cierre de alta presión

conexión de tubos en los dos lados, sin tuerca y anillo cortante

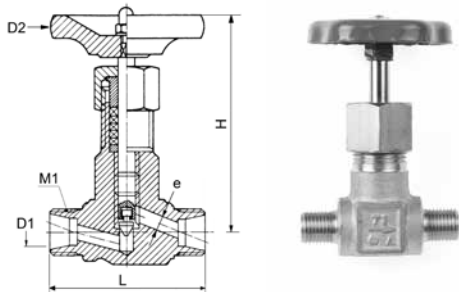

XAVD-..L/S

Type-D1	Mat.-Nr.	PN	M1	D2	H	L	e	g/Stk
XAVD-12L	806.7002.120.20	250	18x1.5	70.0	85.0	65.0	5.0	402
XAVD-08S	806.7002.080.30	400	16x1.5	70.0	85.0	65.0	5.0	374
XAVD-10S	806.7002.100.30	400	18x1.5	70.0	85.0	65.0	6.0	380
XAVD-12S	806.7002.120.30	400	20x1.5	70.0	85.0	65.0	6.0	402

D1=Rohraußen-Ø
M1=metrisches Anschlußgewinde
e=kleinster Innen-Ø

D1=tube outside diameter
M1=metric connecting thread
e=minimum inside diameter

D1=Ø exterior del tubo
M1=rosca métrica conexión
e=Ø interior mínimo

Hochdruck-Absperrventile

beidseitig Schneidringanschluss

High pressure needle valves

double-sided cutting ring connection

Válvulas de cierre de alta presión

conexión de anillo cortante en los dos lados

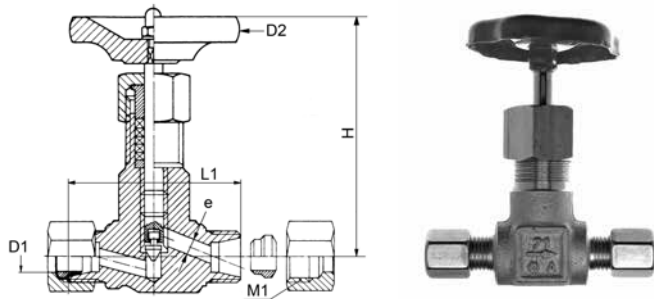

AVD-..L/S

Type-D1	Mat.-Nr.	PN	M1	D2	H	L1	e	g/Stk
AVD-12L	808.7002.120.20	250	18x1.5	70.0	85.0	65.0	5.0	476
AVD-08S	808.7002.080.30	400	16x1.5	70.0	85.0	65.0	5.0	416
AVD-10S	808.7002.100.30	400	18x1.5	70.0	85.0	65.0	6.0	443
AVD-12S	808.7002.120.30	400	20x1.5	70.0	85.0	65.0	6.0	476

Baumaße sind Ungefährmaße bei angezogener Überwurfmutter.

Sizes are approximate dimensions at tightened nut.

Las medidas son aproximadas con la tuerca de unión apretada.

Artikel auch als NC Ausführung erhältlich.

Articles also available as NC version.

Artículos también disponibles como versión NC.

D1=Rohraußen-Ø
M1=metrisches Anschlußgewinde
e=kleinster Innen-Ø

D1=tube outside diameter
M1=metric connecting thread
e=minimum inside diameter

D1=Ø exterior del tubo
M1=rosca métrica conexión
e=Ø interior mínimo

Mehr als Verschraubungen

- erfahrene Mitarbeiter mit grossem Know-how
- Montageschulungen in Ihrem Haus
- Beratung für Spezial-Anwendungen

More than fittings

- competent employees with extensive knowledge
- assembly trainings on your premises
- consulting for special applications

Más que racores

- empleados competentes con un know-how extenso
- cursos de montaje en sus dependencias
- consultoría para aplicaciones especiales



Technische Informationen

Technical Information

Información Técnica

**Hochdruck-Absperrventil
Typ AVI**

Kopfstück eingeschraubt

**High pressure needle valve
Type AVI**

Screwed in bonnet

**Válvula de cierre de alta presión
Tipo AVI**

Cabeza enroscada

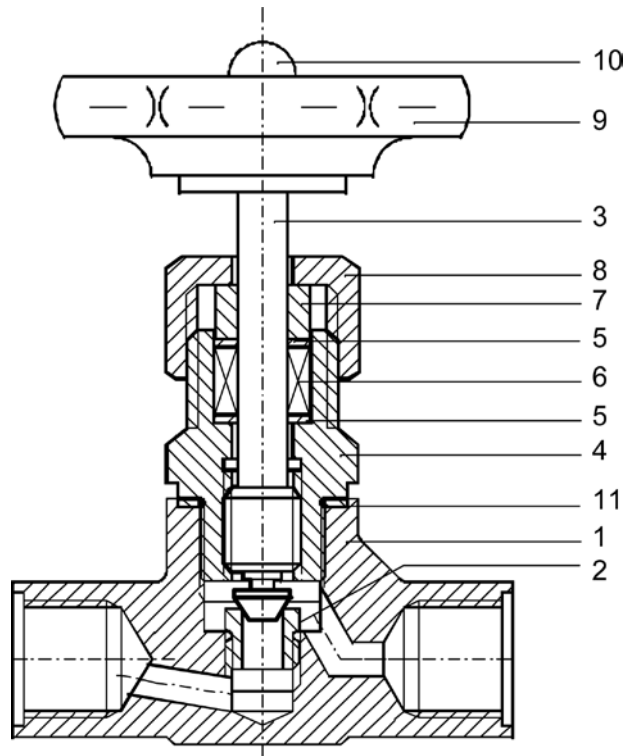

50

	Bauteil Part Componente	Werkstoff Material Material		Bauteil Part Componente	Werkstoff Material Material
1	Gehäuse Body Carcasa	Edelstahl 1.4571 / AISI 316 Ti Stainless steel 1.4571 / AISI 316 Ti Acero inoxidable 1.4571 / AISI 316 Ti	7	Stopfbuchse Gland Prensaestopa	Edelstahl 1.4571 / AISI 316 Ti Stainless steel 1.4571 / AISI 316 Ti Acero inoxidable 1.4571 / AISI 316 Ti
2	Sitz eingeschraubt Screw-in seat Sentada enroscada	Edelstahl 1.4571 / AISI 316 Ti Stainless steel 1.4571 / AISI 316 Ti Acero inoxidable 1.4571 / AISI 316 Ti	8	Überwurfmutter Nut Tuerca	Edelstahl 1.4571 / AISI 316 i Stainless steel 1.4571 / AISI 316 Ti Acero inoxidable 1.4571 / AISI 316 Ti
3	Spindel Stem Husillo	Edelstahl 1.4571 / AISI 316 Ti Stainless steel 1.4571 / AISI 316 Ti Acero inoxidable 1.4571 / AISI 316 Ti	9	Handrad Hand wheel Volante	Stahlblech Steel plate Chapa de acero
4	Kopfstück Bonnet Cabeza	Edelstahl 1.4571 / AISI 316 Ti Stainless steel 1.4571 / AISI 316 Ti Acero inoxidable 1.4571 / AISI 316 Ti	10	Mutter Nut Tuerca	Edelstahl 1.4301 / AISI 304 Stainless steel 1.4301 / AISI 304 Acero inoxidable 1.4301 / AISI 304
5	Abstreifring Scraper ring Anillo despojarse	Novapress Novapress Novapress	11	Dichtung Seal Junta	Edelstahl 1.4571 / AISI 316 Ti Stainless steel 1.4571 / AISI 316 Ti Acero inoxidable 1.4571 / AISI 316 Ti
6	Packung Gland packing Empaquetadura	PTFE PTFE PTFE			

Konstruktionsaufbau

Alle EXMAR-Ventilgehäuse sind aus Edelstahl Werkstoff 1.4571 / AISI 316 Ti geschmiedet. Eine anschließende Wärmebehandlung garantiert ein optimales Materialgefüge.

Diese Ventile haben ein innenliegendes Spindelgewinde. Die großzügig dimensionierte Spindel ist feinstbearbeitet und garantiert somit eine leichte Betätigung bei geringstem Verschleiß der Stopfbuchsenpackung.

Durch die 2-teilige Spindel wird eine sichere Abdichtung bei dünnflüssigen Medien gewährleistet.

Bei allen Ausführungen ist der Kegel in die Spindel "ingerollt", so dass der Kegel drehbar, aber selbstzentrierend und unlösbar ist.

Prüfungen

EXMAR-Ventile werden auf Gehäusefestigkeit und Dichtheit geprüft. Hierbei gelten die Anforderungen nach DIN EN 12266-1.

Zeugnisse

Auf Wunsch werden Werksbescheinigungen oder Werkszeugnisse nach DIN EN 10204 erstellt.

Druck-Temperatur-Diagramm

Hochdruck-Absperrventil Typ AVI PTFE

Design

All EXMAR valve bodies are forged from stainless steel material 1.4571 / AISI 316 Ti. A final heat treatment guarantees optimum material structure.

These valves are built with an internal thread stem. The generously dimensioned stem is micro-machined and this guarantees smooth operation with very low wear of the gland packing.

The 2-parts stem ensures a secure sealing with highly fluid media.

In all versions the taper is "rolled into" the spindle so that the taper is rotatable but self-centering and non-detachable.

Tests

EXMAR valves are tested for the using stability and tightness. The requirements are specified in DIN EN 12266-1.

Certificates

Certificates of conformity or certificates of compliance in accordance with DIN EN 10204 will be provided upon request.

Pressure-Temperature-Diagram

High pressure needle valve Type AVI PTFE

Diseño constructivo

Todos los cuerpos de válvulas EXMAR están forjados de acero inoxidable 1.4571 / AISI 316 Ti. El tratamiento térmico siguiente garantiza una estructura óptima del material.

Las válvulas tienen una rosca de husillo interior. El husillo sobredimensionado está superacabado y garantiza facilidad de accionamiento con mínimo desgaste de la empaquetadura para prensaestopas.

El husillo de dos piezas garantiza una hermetización segura para medios líquidos.

En todas las versiones, el cono está "enrollado" dentro del husillo: aunque puede girar, es autocentrante y no extraíble.

Verificaciones

Las válvulas EXMAR son comprobadas en relación con la resistencia del cuerpo y la estanquidad. Se aplican los requisitos según DIN EN 12266-1.

Certificados

Bajo demanda se entregarán certificados de fábrica o de material según DIN EN 10204.

Diagrama de presión y temperatura

Válvula de cierre de alta presión Tipo AVI PTFE

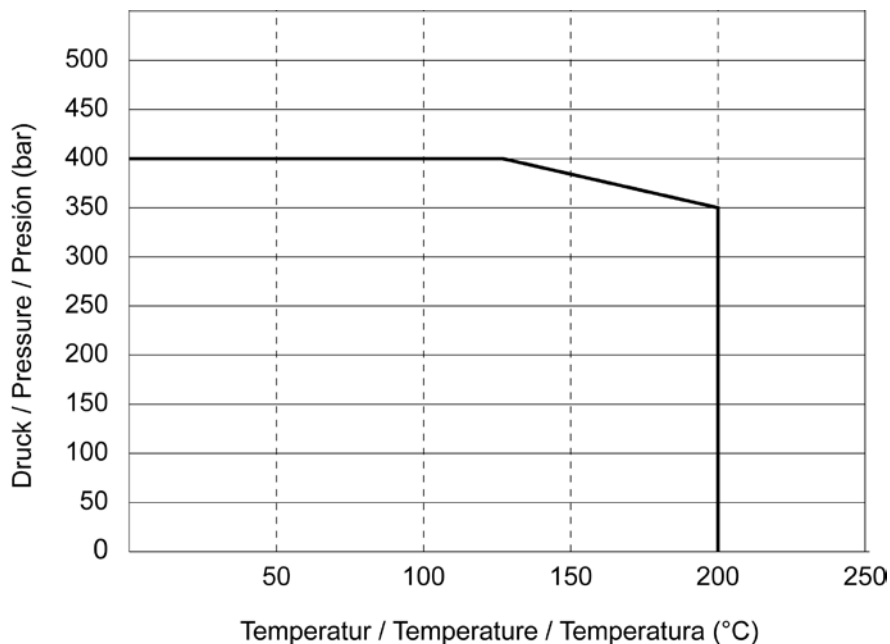

Anmerkung:

Der maximal mögliche Betriebsdruck PN kann auf Grund der Anschlüsse unter dem als maximal angegebenen Nenndruck PN liegen. Sicherheitsfaktor: 1.5-fach

Remark:

Due to the connectors, the maximum possible working pressure PN can be lower than the maximum nominal pressure PN specified. Safety factor: 1.5 times

Nota:

Por cuestiones relacionadas con las conexiones, la presión de servicio máxima PN puede ser menor que la presión nominal PN señalada. Factor de seguridad: 1.5 veces

Hochdruck-Absperrventile

beidseitig Innengewinde

High pressure needle valves

double-sided female thread

Válvulas de cierre de alta presión

rosca interior en los dos lados

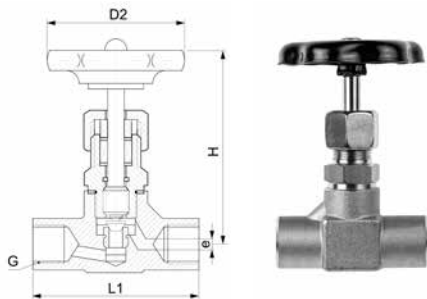

AVI-G

Type-G	Mat.-Nr.	PN	D2	G	H	L1	e	g/Stk
G=Rohrgewinde (zylindrisch)		G=BSP thread (parallel)					G=rosca de conexión (cilíndrica)	
AVI-G 3.8	808.7003.060	400	80.0	3/8	113.0	80.0	6.0	750
AVI-G 1.2	808.7003.080	400	80.0	1/2	113.0	80.0	8.0	920
• AVI-G 1.1	808.7003.160	400	80.0	1	160.0	100.0	11.8	1200

Gewinde nach ISO 228/1

female thread to ISO 228/1

rosca según ISO 228/1

e=kleinster Innen-Ø
•=abweichende Form

e=minimum inside diameter
•=different form

e=Ø interior mínimo
•=forma diferente

Hochdruck-Absperrventile

beidseitig Rohranschluss, ohne Mutter und Schneidring

High pressure needle valves

double-sided tube connection, without nut and cutting ring

Válvulas de cierre de alta presión

conexión de tubos en los dos lados, sin tuerca y anillo cortante

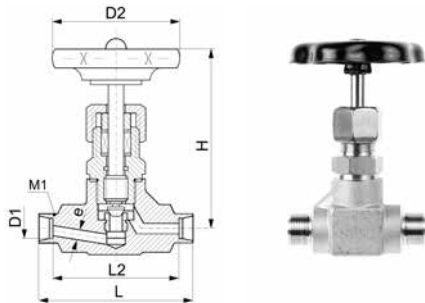

XAVI-..L/S

Type-D1	Mat.-Nr.	PN	M1	D2	H	L	L2	e	g/Stk
XAVI-08L	806.7001.080.20	250	14x1.5	80.0	115.0	80.0	60.0	5.0	670
XAVI-12L	806.7001.120.20	250	18x1.5	80.0	115.0	80.0	58.0	7.0	700
• XAVI-22L	806.7001.220.20	250	30x2.0	80.0	130.0	130.0	102.0	12.0	780
XAVI-08S	806.7001.080.30	400	16x1.5	80.0	115.0	80.0	56.0	6.0	680
XAVI-10S	806.7001.100.30	400	18x1.5	80.0	115.0	80.0	56.0	7.0	680
XAVI-12S	806.7001.120.30	400	20x1.5	80.0	115.0	80.0	56.0	8.0	690
• XAVI-20S	806.7001.200.30	400	30x2.0	80.0	130.0	130.0	98.0	12.0	1255

D1=Rohraußen-Ø
M1=metrisches Anschlußgewinde
e=kleinster Innen-Ø
•=abweichende Form

D1=tube outside diameter
M1=metric connecting thread
e=minimum inside diameter
•=different form

D1=Ø exterior del tubo
M1=rosca métrica conexión
e=Ø interior mínimo
•=forma diferente

Hochdruck-Absperrventile

beidseitig Schneidringanschluss

High pressure needle valves

double-sided cutting ring connection

Válvulas de cierre de alta presión

conexión de anillo cortante en los dos lados

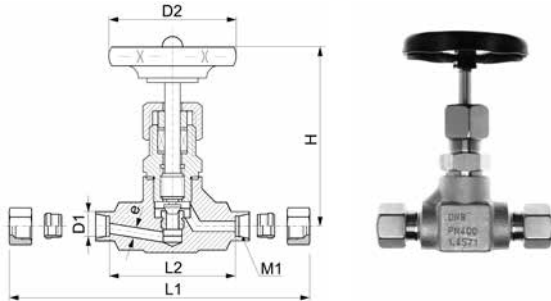

AVI-..L/S

Type-D1	Mat.-Nr.	PN	M1	D2	H	L1	L2	e	g/Stk
AVI-08L	808.7001.080.20	250	14x1.5	80.0	115.0	96.0	60.0	5.0	700
AVI-12L	808.7001.120.20	250	18x1.5	80.0	115.0	96.0	58.0	7.0	762
• AVI-22L	808.7001.220.20	250	30x2.0	80.0	130.0	148.0	102.0	12.0	962
AVI-08S	808.7001.080.30	400	16x1.5	80.0	115.0	131.0	56.0	6.0	725
AVI-10S	808.7001.100.30	400	18x1.5	80.0	115.0	133.0	56.0	7.0	745
AVI-12S	808.7001.120.30	400	20x1.5	80.0	115.0	133.0	56.0	8.0	762
• AVI-20S	808.7001.200.30	400	30x2.0	80.0	130.0	152.0	98.0	12.0	1480

Baumaße sind Ungefährmaße bei angezogener Überwurfmutter.

Sizes are approximate dimensions at tightened nut.

Las medidas son aproximadas con la tuerca de unión apretada.

Artikel auch als NC Ausführung erhältlich.

Articles also available as NC version.

Artículos también disponibles como versión NC.

D1=Rohr außen-Ø
 M1=metrisches Anschlußgewinde
 e=kleinster Innen-Ø
 •=abweichende Form

D1=tube outside diameter
 M1=metric connecting thread
 e=minimum inside diameter
 •=different form

D1=Ø exterior del tubo
 M1=rosca métrica conexión
 e=Ø interior mínimo
 •=forma diferente

Manometer-Ventile

ohne Prüfanschluss, DIN 16270

Gauge valves

without test connection for pressure gauges, DIN 16 270

Válvulas manométricas

sin conexión de control, DIN 16270

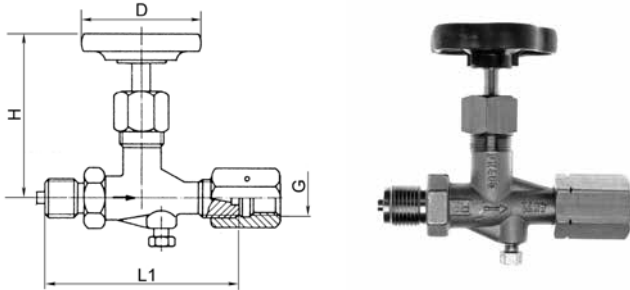

MV-R 16270

Type	Mat.-Nr.	PN	D	G	H	L1	g/Stk
G=Rohrgewinde (zylindrisch)		G=BSP thread (parallel)			G=rosca de conexión (cilíndrica)		
MV-R 16270 MZ-VA	808.9003.080	400	60.0	1/2	95.0	100.0	530

Packung: PTFE (Graphit auf Anfrage)
 Handrad: Kunststoff
 Werkstoff: Edelstahl 1.4571 / AISI 316 Ti

Packing: PTFE (graphite on request)
 Handwheel: plastic
 Material: stainless steel 1.4571 / AISI 316 Ti

Empaquetado: PTFE (grafito bajo demanda)
 Volante: plástico
 Material: acero inoxidable 1.4571 / AISI 316 Ti

Temperaturbereich:
 mit PTFE max. +200°C
 mit Graphit max. +400°C

Temperature range:
 with PTFE max. +200°C
 with graphite max. +400°C

Intervalo de temperatura:
 con PTFE máx. +200°C
 con grafito máx. +400°C

Druck:
 Sicherheitsfaktor: 1.5-fach

Pression:
 Safety factor: 1.5 times

Presión:
 Factor de seguridad: 1.5 veces

1. Form A mit Spannmuffe
2. Eingang Zapfen G1/2
3. Ausgang Zapfen G1/2 - Linksgewinde, mit passender Spannmuffe Links-/Rechtsgewinde
4. Manometerventile sind entsprechend der DIN-Vorschriften gefertigt und werden zum Absperrern von Druckmessgeräten eingesetzt.

1. Form A with clamping socket
2. Inlet plug G1/2
3. Outlet plug G1/2 - left-hand thread, with corresponding clamping socket left/right-hand thread
4. Manometer valves are manufactured to DIN regulations and are used to close off pressure measurement devices.

1. Forma A con manguito de apriete
2. Vástago entrada G1/2
3. Vástago salida G1/2 rosca izquierda, con manguito de apriete adecuado, rosca izquierda/derecha
4. Las válvulas manométricas se han fabricado de conformidad con la normativa DIN y se utilizan para cerrar equipos manométricos.

Manometer-Ventile

mit Prüfanschluss, DIN 16271

Gauge valves

with test connection for pressure gauges, DIN 16271

Válvulas manométricas

con conexión de prueba, DIN 16271

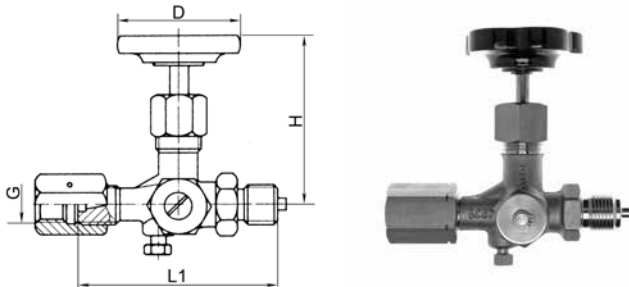

MV-R 16271

Type	Mat.-Nr.	PN	D	G	H	L1	g/Stk
G=Rohrgewinde (zylindrisch)		G=BSP thread (parallel)			G=rosca de conexión (cilíndrica)		
MV-R 16271 MZ-VA	808.9004.080	400	60.0	1/2	95.0	100.0	682

Packung: PTFE (Graphit auf Anfrage)
 Handrad: Kunststoff
 Werkstoff: Edelstahl 1.4571 / AISI 316 Ti

Packing: PTFE (graphite on request)
 Handwheel: plastic
 Material: stainless steel 1.4571 / AISI 316 Ti

Embalaje: PTFE (grafito bajo demanda)
 Volante: plástico
 Material: acero inoxidable 1.4571 / AISI 316 Ti

Temperaturbereich:
 mit PTFE max. +200°C
 mit Graphit max. +400°C

Temperature range:
 with PTFE max. +200°C
 with graphite max. +400°C

Intervalo de temperatura:
 con PTFE máx. +200°C
 con grafito máx. +400°C

Druck:
 Sicherheitsfaktor: 1.5-fach

Pression:
 Safety factor: 1.5 times

Presión:
 Factor de seguridad: 1.5 veces

1. Form A mit Spannmuffe
2. Eingang Zapfen G1/2
3. Ausgang Zapfen G1/2 - Linksgewinde, mit passender Spannmuffe Links-/Rechtsgewinde
4. Prüfanschluss M20x1.5 mit Verschlusskappe und Dichtlinse
5. Manometerventile sind entsprechend der DIN-Vorschriften gefertigt und werden zum Absperrn von Druckmeßgeräten eingesetzt.

1. Form A with clamping socket
2. Inlet plug G1/2
3. Outlet plug G1/2 - left-hand thread, with corresponding clamping socket left/right-hand thread
4. Test connection M20x1.5 with end cap and sealing lens
5. Manometer valves are manufactured to DIN regulations and are used to close off pressure measurement devices.

1. Forma A con manguito de apriete
2. Vástago entrada G1/2
3. Vástago salida G1/2 rosca izquierda, con manguito de apriete adecuado, rosca izquierda/derecha
4. Conexión de control M20x1.5 con tapón y junta lenticular
5. Las válvulas manométricas se han fabricado de conformidad con la normativa DIN y se utilizan para cerrar equipos manométricos.

Drosselventile
Throttle valves
Válvulas reguladoras

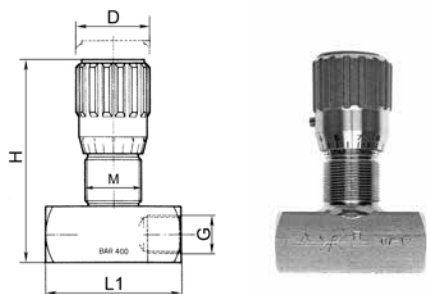

EFT 2257/2

Type -G	Mat.-Nr.	PN	max. l/min	D	G	M	H	L1	g/Stk
G=Rohrgewinde (zylindrisch)		G=BSP thread (parallel)				G=rosca de conexión (cilíndrica)			
EFT-2257/2-G 1.8	808.9006.020	400	10	22.0	1/8	17x1.0	59.0	38.0	110
EFT-2257/2-G 1.4	808.9006.040	400	15	27.0	1/4	20x1.0	71.0	49.5	204
EFT-2257/2-G 3.8	808.9006.060	400	30	33.0	3/8	25x1.5	84.0	59.0	382
EFT-2257/2-G 1.2	808.9006.080	400	50	38.0	1/2	30x1.5	97.0	68.0	612
EFT-2257/2-G 3.4	808.9006.120	400	80	47.0	3/4	40x1.5	120.5	86.0	1340

Zweiwege-Nadelventile zur Durchflussregelung in beide Richtungen.

Regelung der Durchflussrichtung durch Dezimalskala auf dem Griff. Unbeabsichtigte Bedienung durch Feststellschraube auf dem Griff nicht möglich.

Metallische Abdichtung.

Schalttafelmontage mit Nutmutter auf Anfrage.

Betriebstemperatur: -20°C bis +100°C

Filtrierungsgrad: 25 µm

Sicherheitsfaktor Druck: 1.5-fach

Auf Anfrage:

Anschlüsse Außen-/ Innengewinde, Dichtung aus FKM, Gewinde NPT, Hutmuttern

Two-way needle valves are suitable for flow control on both directions.

Flow control by a decimal scale on the handwheel. Unintentional operations are not possible due to the locking screw on the handwheel.

Metallic sealing.

Panel mounting with nut on request.

Working temperature: -20°C to +100°C

Filtration grade: 25µm

Safety factor pressure: 1.5 times

On request:

Connections male / female, FKM gaskets, NPT threads, cap nuts

Válvulas de aguja de dos vías para la regulación bidireccional del flujo.

Regulación de la dirección del flujo mediante escala decimal en la palanca. Seguro contra accionamiento involuntario mediante tornillo de bloqueo en la palanca.

Cierre hermético metálico.

Montaje en cuadro de mando con tuerca de sombrerete a petición.

Temperatura de servicio: -20°C a +100°C

Grado de filtración: 25 µm

Factor de seguridad de presión: 1.5 veces

Bajo demanda:

Conexiones rosca exterior/interior, junta de FKM, rosca NPT, tuercas de sombrerete

Drosselrückschlagventile
Throttle check valves
Válvulas reguladoras de retención

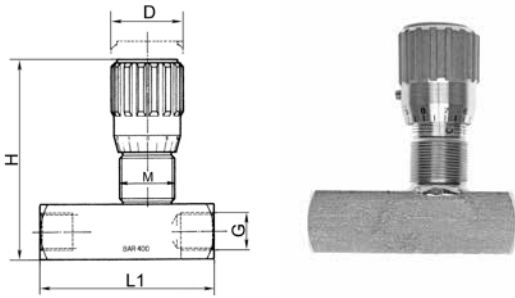

EFT 2257/5

Type -G	Mat.-Nr.	PN	max. l/min	D	G	M	H	L1	g/Stk
G=Rohrgewinde (zylindrisch)		G=BSP thread (parallel)				G=rosca de conexión (cilíndrica)			
EFT-2257/5-G 1.4	808.9005.040	400	15	27.0	1/4	20x1.0	71.0	66.0	254
EFT-2257/5-G 3.8	808.9005.060	400	30	33.0	3/8	25x1.5	84.0	79.0	466
EFT-2257/5-G 1.2	808.9005.080	400	50	38.0	1/2	30x1.5	97.0	94.5	776

Durchflussregelung in eine Richtung bzw. Durchflussabspernung, wobei Rückfluss in die entgegengesetzte Richtung möglich ist. Linearität des Durchflusses bei offenem Ventil, Kontrolle des Durchflusses durch Dezimalskala am Griff. Unbeabsichtigte Bedienung durch Feststellschraube auf dem Griff nicht möglich. Metallische Abdichtung. Schalttafelmontage auf Anfrage.

Öffnungsdruck: 0.35 bar
 Betriebstemperatur: -20°C bis +100°C
 Filtrationsgrad: 25µm
 Sicherheitsfaktor Druck: 1.5-fach

Auf Anfrage:
 Dichtung aus FKM, Gewinde NPT, Hutmuttern

Flow control in one direction or shut-off with reflux in the opposite direction possible. Flow linearity during opened-valve. Flow control by decimal scale on the handwheel. Unintentional operations are not possible due to the locking screw on the handwheel. Metallic sealing. Panel mounting on request.

Opening pressure: 0.35 bar
 Working temperature: -20°C to +100°C
 Filtration grade: 25µm
 Safety factor pression: 1.5 times

On request:
 FKM gaskets, NPT threads, cap nuts

Regulación de flujo unidireccional y bloqueo de flujo, con posibilidad de reflujo en dirección contraria. Cierre hermético metálico. Linealidad del flujo con válvula abierta, control del flujo mediante escala decimal en la palanca. Seguro contra accionamiento involuntario mediante tornillo de bloqueo en la palanca. Montaje en cuadro de mando bajo demanda. Presión de apertura: 0.35 bar

Temperatura de servicio: -20°C a +100°C
 Grado de filtración: 25 µm
 Factor de seguridad de presión: 1.5 veces

Bajo demanda:
 Junta de FKM, rosca NPT, tuercas de sombre-rete

**Durchflussdiagramme
EFT**

**Flow Diagrams
EFT**

**Diagramas de Flujo
EFT**

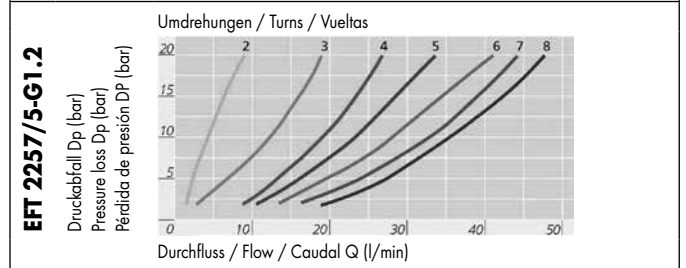
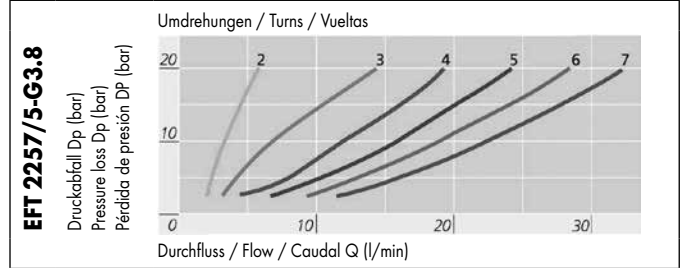
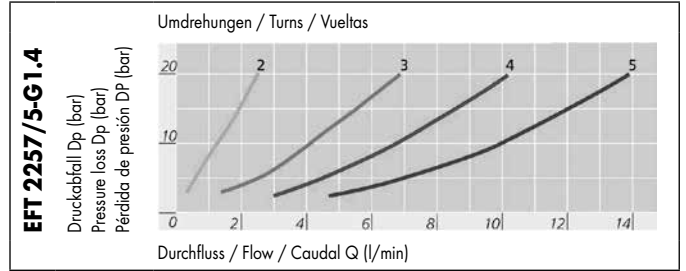
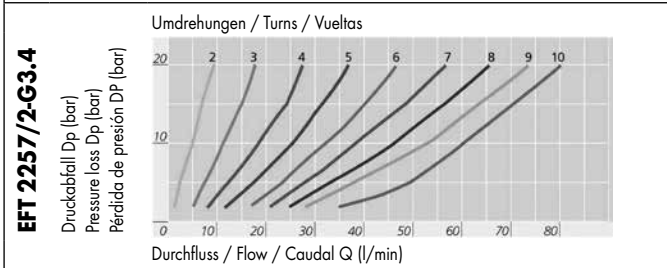
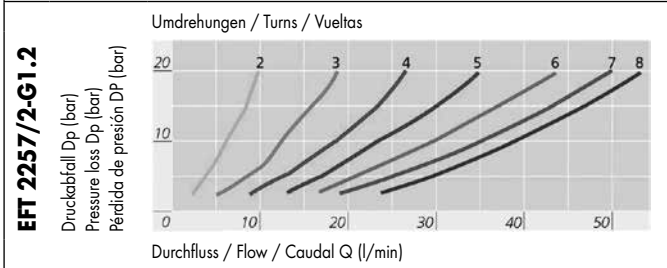
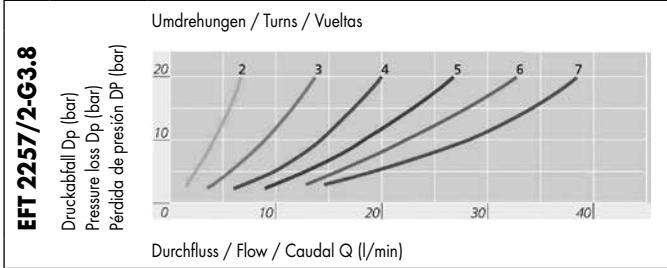
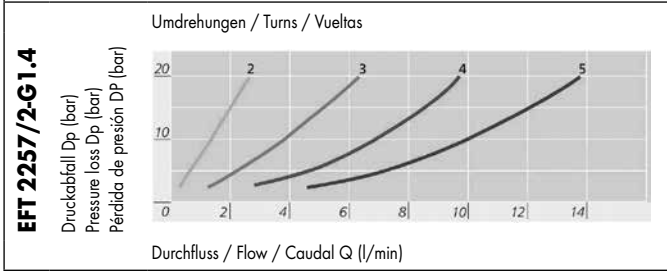
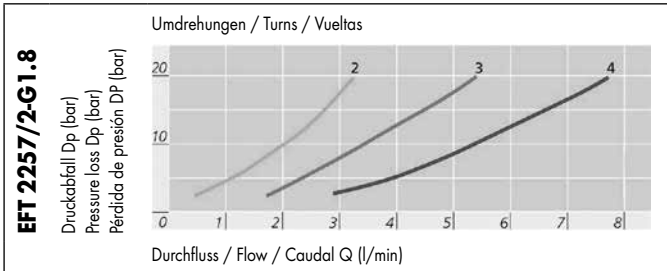

Schnellverschluss-Kupplungen ISO "B", Kuppler/Stecker
Quick disconnect couplings ISO "B", couplers/nipples
Acoplamiento de cierre rápido ISO "B", manguito/racores

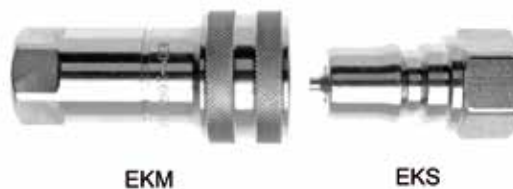
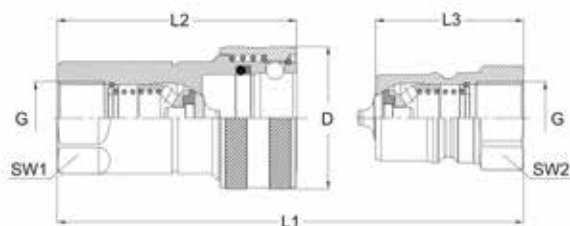

EKM/EKS

Type -G	Mat.-Nr.	PN	D	G	L1	L2	SW1	g/Stk
G=Rohrgewinde (zylindrisch)	G=BSP thread (parallel)			G=rosca de conexión (cilíndrica)				
EKM-106/G1.4	736.7155.091	300	28.0	1/4	74.0	58.5	19	165
EKM-210/G3.8	736.7155.092	250	35.0	3/8	78.0	64.0	24	229
EKM-313/G1.2	736.7155.093	250	42.0	1/2	91.0	73.0	30	480
EKM-420/G3.4	736.7155.094	250	52.0	3/4	107.0	87.5	36	628
EKM-520/G1.1	736.7155.095	200	60.0	1	126.0	103.0	41	1250

Type -G	Mat.-Nr.	PN	G	L1	L3	SW2	g/Stk
G=Rohrgewinde (zylindrisch)	G=BSP thread (parallel)			G=rosca de conexión (cilíndrica)			
EKS-106/G1.4	736.7156.091	300	1/4	74.0	37.0	19	38
EKS-210/G3.8	736.7156.092	250	3/8	78.0	39.0	22	60
EKS-313/G1.2	736.7156.093	250	1/2	91.0	45.5	27	110
EKS-420/G3.4	736.7156.094	250	3/4	107.0	54.0	36	218
EKS-520/G1.1	736.7156.095	200	1	126.0	63.0	41	338

50

Werkstoff: Edelstahl 1.4401 / AISI 316

Option: NPT-Gewinde

Dichtungsmaterial: FKM (andere Werkstoffe auf Anfrage)

Betriebstemperatur: -15°C bis +200°C

Sicherheitsfaktor Druck: 2.5-fach

Material: stainless steel 1.4401 / AISI 316

Option: NPT thread

Sealing material: FKM (other materials on request)

Working temperature: -15°C to +200°C

Safety factor pression: 2.5 times

Material: acero inoxidable 1.4401 / AISI 316

Opción: rosca NPT

Material de junta tórica: FKM (otros materiales bajo demanda)

Temperatura de servicio: -15°C a +200°C

Factor de seguridad de presión: 2.5 veces

Gewichtsangabe für gesamte Kupplung

Indicated weight for complete coupling



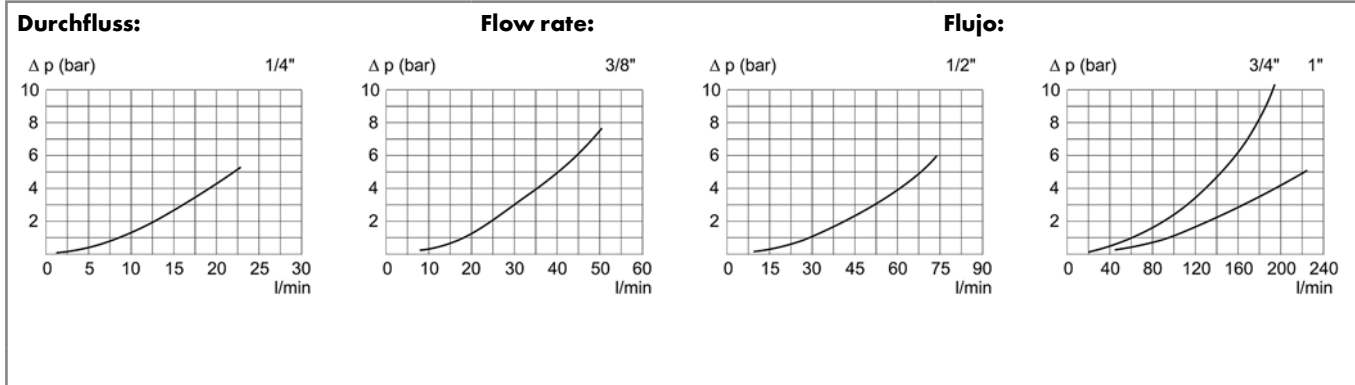





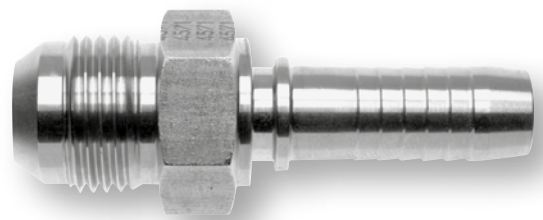











Peso indicado para el acoplamiento completa



Schlaucharmaturen Hose couplings

Conectores de
manguera



Seite/Page/Página	Seite/Page/Página	Seite/Page/Página
<p>Pressfassungen Ferrules Casquillos para prensar</p> <p>60.5-60.7</p>  <p>EF</p>	<p>Nippel mit Dichtkegel und O-Ring, 45°/90° Nipples with taper and O-ring, 45°/90° Espigas con junta conica y junta tórica a 45°/90°</p> <p>60.18-60.19</p>  <p>EDKOL/EDKOS 45°/90°</p>	<p>Nippel mit 74° JIC Konus, gerade Nipples with 74° JIC taper, straight Espigas con cono de 74° JIC rectas</p> <p>60.27</p>  <p>EDKJ</p>
<p>Nippel mit Rohrstützen, gerade Nipples with pipe connector, straight Espiga lisa recta</p> <p>60.8</p>  <p>EBEL/EBES</p>	<p>Außengewinde-Nippel mit 24° Konus Male adaptor nipples with 24° taper Espigas para roscar con cono de 24°</p> <p>60.20</p>  <p>ECEL/ECES</p>	<p>Außengewinde-Nippel, 74° JIC, 45°/90° Male adaptor nipples, 74° JIC, 45°/90° Espigas para roscar de 74° JIC a 45°/90°</p> <p>60.28-60.29</p>  <p>EDKJ 45°/90°</p>
<p>Nippel mit Rohrstützen, 45°/90° Nipples with pipe connector, 45°/90° Espigas lisa a 45°/90°</p> <p>60.9-60.10</p>  <p>EBEL/EBES 45°/90°</p>	<p>Außengewinde-Nippel mit 60° Konus Male adaptor nipples with 60° taper Espigas para roscar cono de 60°</p> <p>60.21</p>  <p>EAGR</p>	<p>Schlauch-Adapter Hose adaptors Adaptadores para tubos flexibles</p> <p>60.30</p>  <p>ESA</p>
<p>Nippel mit Universal-Dichtkegel, gerade Nipples with universal taper, straight Espigas con junta cónica universal rectas</p> <p>60.11</p>  <p>EDKL</p>	<p>Außengewinde-Nippel BSPP Male adaptor nipples BSPP Espigas para roscar BSPP</p> <p>60.22</p>  <p>EAGF</p>	<p>Schlauch-Überwurfmutter Hose nuts Tuercas de unión para tubos flexibles</p> <p>60.31</p>  <p>SÜM</p>
<p>Nippel mit Universal-Dichtkegel, 45°/90° Nipples with universal taper, 45°/90° Espigas con junta conica universal a 45°/90°</p> <p>60.12-60.13</p>  <p>EDKL 45°/90°</p>	<p>Außengewinde-Nippel BSPT Male adaptor nipples BSPT Espigas para roscar BSPT</p> <p>60.23</p>  <p>EAGK</p>	
<p>Nippel mit Dichtkegel, gerade Nipples with taper, straight Espigas con junta cónica rectas</p> <p>60.14</p>  <p>EDKR</p>	<p>Außengewinde-Nippel NPT Male adaptor nipples NPT Espigas para roscar NPT</p> <p>60.24</p>  <p>EAGN</p>	
<p>Nippel mit Dichtkegel, 45°/90° Nipples with taper, 45°/90° Espigas con junta conica a 45°/90°</p> <p>60.15-60.16</p>  <p>EDKR 45°/90°</p>	<p>Außengewinde-Nippel NPTF Male adaptor nipples NPTF Espigas para roscar NPTF</p> <p>60.25</p>  <p>EAGNF</p>	
<p>Nippel mit Dichtkegel und O-Ring, gerade Nipples with taper and O-ring, straight Espigas con junta cónica y junta tórica rectas</p> <p>60.17</p>  <p>EDKOL/EDKOS</p>	<p>Außengewinde-Nippel mit 74° JIC Konus Male adaptor nipples with 74° JIC taper Espigas para roscar con JIC cono de 74°</p> <p>60.26</p>  <p>EAGJ</p>	

Pressmaße
Crimp dimensions
**Dimensiones di
presado**

Schläuche 1 SC, ungeschält Hoses 1 SC, non-skived Mangueras 1 SC, sin pelar		
Pressfassung Typ Ferrules type Tipo de casquillo para presar	theor. Pressmaß Ø Crimp dimension theor. Ø Dimensiones de presado teor. Ø [mm]	Nippel einfallmaß Nipple deformation Compresión de la boquilla [mm]
EF09-DN06	15.1 - 15.5	0.2 - 0.6
EF09-DN08	16.7 - 17.1	0.2 - 0.6
EF09-DN10	19.5 - 19.9	0.3 - 0.7
EF10-DN12	22.9 - 23.3	0.3 - 0.7
EF10-DN16	26.8 - 27.2	0.4 - 0.9
EF10-DN19	30.5 - 30.9	0.5 - 1.0
EF10-DN25	37.2 - 37.6	0.5 - 1.0

Schläuche 2 SC (bis DN 25), 1 SN, 2 TE (bis DN 25), ungeschält Hoses 2 SC (to DN 25), 1 SN, 2 TE (to DN 25), non-skived Mangueras 2 SC (hasta DN 25), 1 SN, 2 TE (hasta DN 25), sin pelar		
Pressfassung Typ Ferrules type Tipo de casquillo para presar	theor. Pressmaß Ø Crimp dimension theor. Ø Dimensiones de presado teor. Ø [mm]	Nippel einfallmaß Nipple deformation Compresión de la boquilla [mm]
EF10-DN06	15.8 - 16.3	0.2 - 0.6
EF10-DN08	17.4 - 17.9	0.2 - 0.6
EF10-DN10	20.5 - 21.0	0.3 - 0.7
EF10-DN12	24.2 - 24.7	0.3 - 0.7
EF10-DN16	28.1 - 28.8	0.4 - 0.9
EF10-DN19	31.9 - 32.4	0.5 - 1.0
EF10-DN25	38.8 - 39.4	0.5 - 1.0
EF10-DN31	44.6 - 47.5	0.5 - 1.0
EF10-DN38	53.2 - 55.6	0.6 - 1.2
EF10-DN51	66.0 - 68.5	0.6 - 1.2

Schläuche 2 SN, ungeschält Hoses 2 SN, non-skived Mangueras 2 SN, sin pelar		
Pressfassung Typ Ferrules type Tipo de casquillo para prensar	theor. Pressmaß Ø Crimp dimension theor. Ø Dimensiones de prensado teor. Ø [mm]	Nippel­einfallmaß Nipple deformation Compresión de la boquilla [mm]
EF20-DN06	18.1 - 18.9	0.2 - 0.6
EF20-DN08	19.6 - 20.7	0.2 - 0.6
EF20-DN10	21.8 - 23.0	0.3 - 0.7
EF20-DN12	25.2 - 26.6	0.3 - 0.7
EF20-DN16	28.1 - 29.7	0.4 - 0.9
EF20-DN19	31.9 - 33.7	0.5 - 1.0
EF20-DN25	40.6 - 42.4	0.5 - 1.0
EF20-DN31	50.0 - 52.0	0.5 - 1.0
EF20-DN38	57.8 - 59.8	0.6 - 1.2
EF20-DN51	70.5 - 72.5	0.6 - 1.2

Die Press- und Nippel­einfallmaße sind Richtwerte und abhängig von Schlauchtyp, Toleranzen und Hersteller. Die Werte unterliegen nicht dem Änderungsdienst. Das ordnungsgemäße Verpressen der Armatur ist vom Schlauchkonfektionär mit entsprechenden Mitteln zu prüfen.

Both crimp and nipple deformation dimensions are guide values and depend on hose type, tolerance and manufacturer. These values are not considered for our modification information service. The correct mounting of the hose couplings is to be checked with appropriate means by who crimps them.

Los valores de prensado y compresión de las boquillas son indicativos y dependen del tipo de manguera, su tolerancia y el fabricante. Estos valores no se toman en cuenta para el servicio de información de modificaciones. Quien confecciona las mangueras debe verificar la calidad de prensado de las boquillas con herramientas apropiadas.

Pressfassungen

für ungeschälte Hydraulikschläuche 1SC (DIN 857)

Ferrules

for non-skived hydraulic hoses 1SC (DIN 857)

Casquillos para prensar

para mangueras hidráulicas sin pelar 1SC (DIN 857)

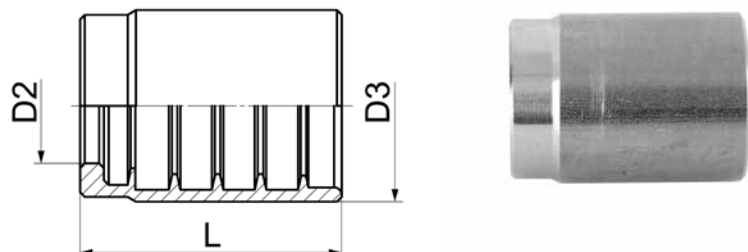

EF-09

Type -DN	Mat.-Nr.	D2	D3	L	g/Stk
EF09-DN06	736.8250.060	11.0	18.5	27.5	20
EF09-DN08	736.8250.080	12.0	20.5	27.5	24
EF09-DN10	736.8250.100	14.5	23.5	30.0	34

Pressfassungen

für ungeschälte Hydraulikschläuche 1SC* (DIN 857), 2SC (DIN 857), 2TE (DIN 854), 1SN (DIN 853)

Ferrules

for non-skived hydraulic hoses 1SC* (DIN 857), 2SC (DIN 857), 2TE (DIN 854), 1SN (DIN 853)

Casquillos para prensar

para mangueras hidráulicas sin pelar 1SC* (DIN 857), 2SC (DIN 857), 2TE (DIN 854), 1SN (DIN 853)

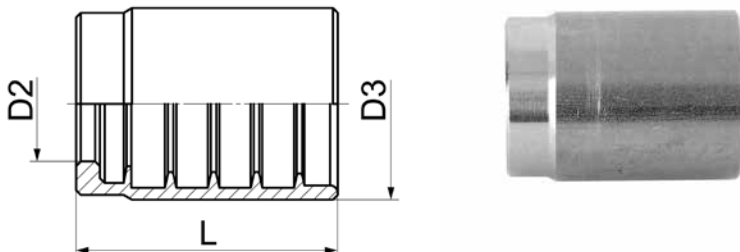

EF-10

Type-DN	Mat.-Nr.	D2	D3	L	g/Stk
EF10-DN06	736.8051.060	12.0	20.0	27.5	22
EF10-DN08	736.8051.080	13.0	22.0	27.5	26
EF10-DN10	736.8051.100	16.0	25.0	30.0	37
EF10-DN12	736.8051.120	19.0	28.0	33.0	45
EF10-DN16	736.8051.160	21.5	32.0	35.0	64
EF10-DN19	736.8051.200	25.0	36.0	38.0	82
EF10-DN25	736.8051.250	31.5	44.0	46.0	126
EF10-DN31	736.8051.320	38.5	53.0	55.0	185
EF10-DN38	736.8051.400	44.0	61.0	57.0	238
EF10-DN51	736.8051.500	57.0	75.0	70.0	370

*Achtung: Für 1SC-Schläuche Größen DN06, DN08 und DN10 wählen Sie bitte die Pressfassung EF-09

*Please note: For 1SC-hoses sizes DN06, DN08 and DN10 please use the ferrule EF-09

*Atención: Para mangueras 1SC de tamaños DN06, DN08 y DN10 por favor use la casquillo para prensar EF-09

Pressfassungen

für ungeschälte Hydraulikschläuche 2SN (DIN 853)

Ferrules

for non-skived hydraulic hoses 2SN (DIN 853)

Casquillos para prensar

para mangueras hidráulicas sin pelar 2SN (DIN 853)

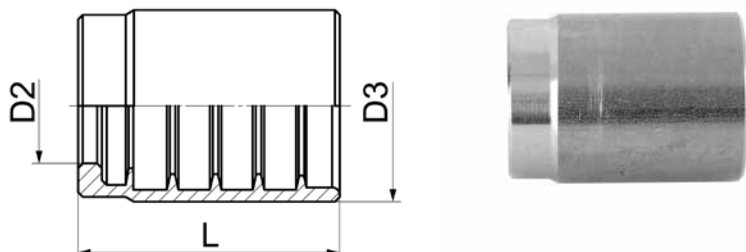

EF-20

Type -DN	Mat.-Nr.	D2	D3	L	g/Stk
EF20-DN06	736.8150.060	11.5	23.0	30.0	37
EF20-DN08	736.8150.080	12.5	25.0	30.0	44
EF20-DN10	736.8150.100	15.0	27.5	32.0	49
EF20-DN12	736.8150.120	19.0	31.0	35.0	70
EF20-DN16	736.8150.160	21.5	34.0	37.0	80
EF20-DN19	736.8150.200	24.5	38.0	42.0	103
EF20-DN25	736.8150.250	31.0	48.0	50.0	169
EF20-DN31	736.8150.320	38.0	59.0	60.0	260
EF20-DN38	736.8150.400	44.5	67.0	65.0	374
EF20-DN51	736.8150.500	57.5	80.0	79.0	589

Rohrstutzen, gerade
Pipe connectors, straight
Espigas lisa rectas

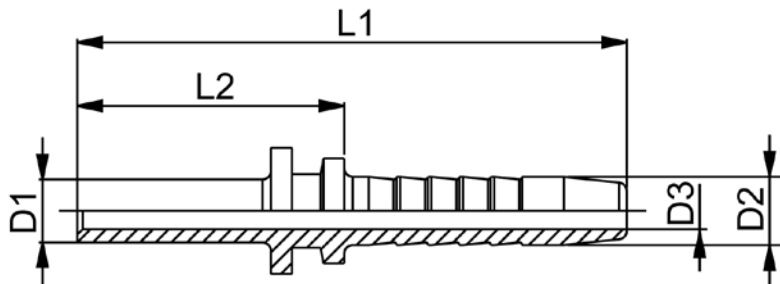

EBEL/EBES

Type -D1 -DN	Mat.-Nr.	D2	D3	L1	L2	g/Stk
EBEL-06L DN06	726.1005.106	6.5	3.5	52.5	25.5	5
EBEL-08L DN06	726.1005.108	6.5	4.0	53.5	26.5	10
EBEL-08L DN08	726.1005.208	8.0	5.0	53.5	26.5	10
EBEL-08L DN10	726.1005.308	9.5	5.5	58.0	28.0	15
EBEL-10L DN08	726.1005.210	8.0	5.0	54.5	27.5	15
EBEL-10L DN10	726.1005.310	9.5	7.0	59.0	29.0	20
EBEL-12L DN10	726.1005.312	9.5	7.0	59.0	29.0	20
EBEL-12L DN12	726.1005.412	13.0	9.0	61.0	29.0	30
EBEL-15L DN10	726.1005.315	9.5	7.0	60.0	30.0	30
EBEL-15L DN12	726.1005.415	13.0	9.5	62.0	30.0	40
EBEL-18L DN12	726.1005.418	13.0	9.5	62.0	30.0	40
EBEL-18L DN16	726.1005.518	16.0	12.0	65.0	31.0	55
EBEL-18L DN19	726.1005.618	19.0	13.0	70.5	31.5	65
EBEL-22L DN16	726.1005.522	16.0	12.0	66.0	32.0	70
EBEL-22L DN19	726.1005.622	19.0	15.0	71.5	32.5	80
EBEL-28L DN25	726.1005.725	25.5	21.0	83.0	35.0	130
EBEL-35L DN31	726.1005.835	32.0	27.0	96.5	41.0	215
EBEL-42L DN38	726.1005.942	38.5	33.0	99.5	42.0	295
EBES-10S DN06	726.1015.110	6.5	4.0	56.0	29.0	15
EBES-12S DN06	726.1015.112	6.5	4.0	57.0	30.0	15
EBES-12S DN08	726.1015.212	8.0	5.0	57.0	30.0	20
EBES-14S DN10	726.1015.314	9.5	7.0	63.0	33.0	30
EBES-14S DN12	726.1015.414	13.0	9.5	65.0	33.0	40
EBES-16S DN12	726.1015.416	13.0	9.5	65.0	33.0	40
EBES-20S DN12	726.1015.420	13.0	9.5	69.0	37.0	55
EBES-20S DN16	726.1015.520	16.0	12.0	71.0	37.0	55
EBES-20S DN19	726.1015.620	19.0	15.0	77.0	38.0	75
EBES-25S DN19	726.1015.625	19.0	15.0	80.5	41.5	100
EBES-25S DN25	726.1015.725	25.5	18.0	90.5	42.5	140
EBES-30S DN25	726.1015.730	25.5	21.0	92.0	44.0	155
EBES-38S DN31	726.1015.838	32.0	27.0	104.5	50.0	295

Rohrstutzen, 45° Bogen

Pipe connectors, 45° elbow

Espigas lisa a 45°

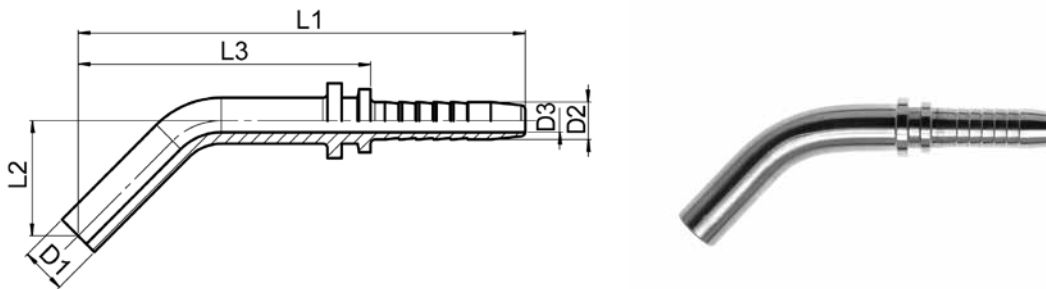

EBEL/EBES-45°

Type-D1-DN	Mat.-Nr.	D2	D3	L1	L2	L3	g/Stk
EBEL-06L DN06-45°	726.1025.106	6.5	3.5	81.0	33.0	54.0	17
EBEL-08L DN06-45°	726.1025.108	6.5	4.0	78.0	20.0	51.0	21
EBEL-08L DN08-45°	726.1025.208	8.0	5.0	78.0	20.0	51.0	26
EBEL-08L DN10-45°	726.1025.308	9.5	5.5	85.0	22.0	55.0	29
EBEL-10L DN08-45°	726.1025.210	8.0	5.0	85.5	22.5	58.5	30
EBEL-10L DN10-45°	726.1025.310	9.5	7.0	86.5	22.5	56.5	35
EBEL-12L DN10-45°	726.1025.312	9.5	7.0	96.0	34.0	66.0	42
EBEL-12L DN12-45°	726.1025.412	13.0	9.0	98.0	33.0	66.0	55
EBEL-15L DN10-45°	726.1025.315	9.5	7.0	102.5	38.0	72.5	66
EBEL-15L DN12-45°	726.1025.415	13.0	9.5	107.5	34.0	75.5	76
EBEL-18L DN12-45°	726.1025.418	13.0	9.5	124.5	47.5	92.5	124
EBEL-18L DN16-45°	726.1025.518	16.0	12.0	125.5	47.5	91.5	133
EBEL-18L DN19-45°	726.1025.618	19.0	13.0	143.5	47.5	104.5	154
EBEL-22L DN16-45°	726.1025.522	16.0	12.0	120.0	32.0	86.0	214
EBEL-22L DN19-45°	726.1025.622	19.0	15.0	143.0	47.0	104.0	226
EBEL-28L DN25-45°	726.1025.725	25.5	21.0	164.0	58.0	116.0	357
EBEL-35L DN31-45°	726.1025.835	32.0	27.0	238.5	64.0	183.0	736
EBEL-42L DN38-45°	726.1025.942	38.5	33.0	256.0	68.0	198.5	1070
EBES-10S DN06-45°	726.1035.110	6.5	4.0	86.5	22.5	59.5	33
EBES-12S DN06-45°	726.1035.112	6.5	4.0	92.0	32.0	65.0	51
EBES-12S DN08-45°	726.1035.212	8.0	5.0	93.0	22.0	66.0	52
EBES-14S DN10-45°	726.1035.314	9.5	7.0	103.0	22.0	73.0	68
EBES-14S DN12-45°	726.1035.414	13.0	9.5	121.0	48.0	89.0	77
EBES-16S DN12-45°	726.1035.416	13.0	9.5	124.5	50.5	92.5	109
EBES-20S DN12-45°	726.1035.420	13.0	9.5	127.0	56.0	95.0	149
EBES-20S DN16-45°	726.1035.520	16.0	12.0	125.0	32.0	91.0	156
EBES-20S DN19-45°	726.1035.620	19.0	15.0	146.0	34.0	107.0	166
EBES-25S DN19-45°	726.1035.625	19.0	15.0	146.0	39.5	107.0	290
EBES-25S DN25-45°	726.1035.725	25.5	18.0	156.0	39.5	108.0	330
EBES-30S DN25-45°	726.1035.730	25.5	21.0	161.5	43.5	113.5	512
EBES-38S DN31-45°	726.1035.838	32.0	27.0	250.5	75.5	196.0	1076

60

Rohrstutzen, 90° Bogen

Pipe connectors, 90° elbow

Espigas lisa a 90°

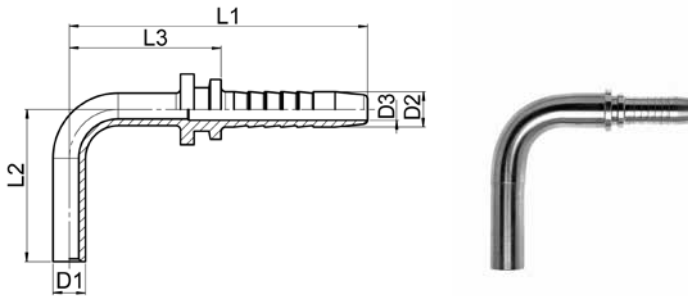

EBEL/EBES-90°

Type-D1-DN	Mat.-Nr.	D2	D3	L1	L2	L3	g/Stk
EBEL-06L DN06-90°	726.1045.106	6.5	3.5	53.0	47.0	26.0	17
EBEL-08L DN06-90°	726.1045.108	6.5	4.0	59.0	32.0	32.0	21
EBEL-08L DN08-90°	726.1045.208	8.0	5.0	59.0	32.0	32.0	26
EBEL-08L DN10-90°	726.1045.308	9.5	5.5	64.0	32.0	34.0	29
EBEL-10L DN08-90°	726.1045.210	8.0	5.0	65.0	36.0	38.0	30
EBEL-10L DN10-90°	726.1045.310	9.5	7.0	66.0	36.0	36.0	35
EBEL-12L DN10-90°	726.1045.312	9.5	7.0	74.0	45.0	44.0	42
EBEL-12L DN12-90°	726.1045.412	13.0	9.0	76.0	44.0	44.0	55
EBEL-15L DN10-90°	726.1045.315	9.5	7.0	73.5	44.5	43.5	66
EBEL-15L DN12-90°	726.1045.415	13.0	9.5	84.5	48.5	52.5	76
EBEL-18L DN12-90°	726.1045.418	13.0	9.5	94.0	65.0	62.0	124
EBEL-18L DN16-90°	726.1045.518	16.0	12.0	97.0	61.0	63.0	133
EBEL-18L DN19-90°	726.1045.618	19.0	13.0	89.0	49.0	50.0	154
EBEL-22L DN16-90°	726.1045.522	16.0	12.0	89.0	56.0	55.0	214
EBEL-22L DN19-90°	726.1045.622	19.0	15.0	95.0	56.0	56.0	226
EBEL-28L DN25-90°	726.1045.725	25.5	21.0	130.0	74.0	82.0	357
EBEL-35L DN31-90°	726.1045.835	32.0	27.0	175.5	109.5	120.0	736
EBEL-42L DN38-90°	726.1045.942	38.5	33.0	188.0	120.0	130.5	1070
EBES-10S DN06-90°	726.1055.110	6.5	4.0	64.0	37.0	37.0	33
EBES-12S DN06-90°	726.1055.112	6.5	4.0	70.0	44.0	43.0	51
EBES-12S DN08-90°	726.1055.212	8.0	5.0	68.0	41.0	41.0	52
EBES-14S DN10-90°	726.1055.314	9.5	7.0	75.0	45.0	45.0	68
EBES-14S DN12-90°	726.1055.414	13.0	9.5	77.0	45.0	45.0	77
EBES-16S DN12-90°	726.1055.416	13.0	9.5	89.0	67.0	57.0	109
EBES-20S DN12-90°	726.1055.420	13.0	9.5	90.0	58.0	58.0	149
EBES-20S DN16-90°	726.1055.520	16.0	12.0	92.0	58.0	58.0	156
EBES-20S DN19-90°	726.1055.620	19.0	15.0	98.0	58.0	59.0	166
EBES-25S DN19-90°	726.1055.625	19.0	15.0	107.5	69.5	68.5	290
EBES-25S DN25-90°	726.1055.725	25.5	18.0	118.5	69.5	70.5	330
EBES-30S DN25-90°	726.1055.730	25.5	21.0	124.0	78.0	76.0	512
EBES-38S DN31-90°	726.1055.838	32.0	27.0	170.0	130.0	115.5	1076

Nippel mit Universal-Dichtkegel, gerade
Nipples with universal taper, straight
Espigas con junta cónica universal rectas

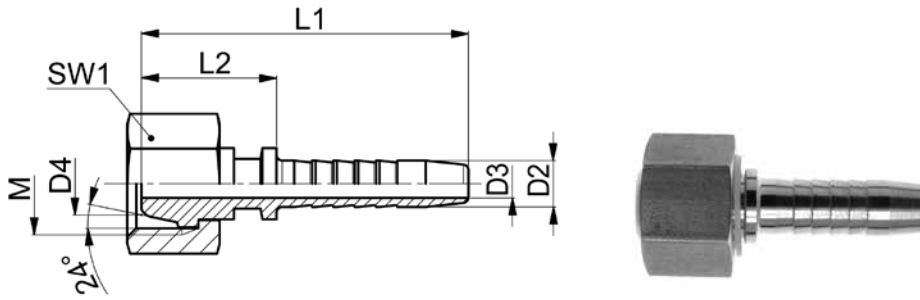

EDKL

Type -D1 -DN	Mat.-Nr.	D2	D3	D4	M	L1	L2	SW1	g/Stk
M=metrisches Gewinde (zylindrisch)	M=metric thread (parallel)	M=rosca métrica (cilíndrica)							
* EDKL-06L DN06	728.3805.106	6.5	4.0	7.3	12x1.5	47.0	20.0	14	20
EDKL-08L DN06	728.3805.108	6.5	4.0	9.3	14x1.5	46.0	19.0	17	29
* EDKL-08L DN08	728.3805.208	8.0	5.0	9.3	14x1.5	47.0	20.0	17	32
EDKL-10L DN06	728.3805.110	6.5	4.0	11.5	16x1.5	46.0	19.0	19	34
EDKL-10L DN08	728.3805.210	8.0	5.0	11.5	16x1.5	46.0	19.0	19	36
* EDKL-10L DN10	728.3805.310	9.5	7.0	11.5	16x1.5	51.5	21.5	19	42
EDKL-12L DN06	728.3805.112	6.5	4.0	13.5	18x1.5	46.0	19.0	22	46
EDKL-12L DN08	728.3805.212	8.0	5.0	13.5	18x1.5	46.0	19.0	22	48
EDKL-12L DN10	728.3805.312	9.5	7.0	13.5	18x1.5	50.0	20.0	22	49
EDKL-15L DN10	728.3805.315	9.5	7.0	16.5	22x1.5	50.0	20.0	27	71
EDKL-15L DN12	728.3805.415	13.0	9.5	16.5	22x1.5	52.0	20.0	27	76
EDKL-18L DN16	728.3805.518	16.0	12.0	19.5	26x1.5	54.0	20.0	32	106
EDKL-22L DN19	728.3805.620	19.0	15.0	23.1	30x2.0	65.0	26.0	36	156
EDKL-28L DN25	728.3805.728	25.5	21.0	29.1	36x2.0	75.0	27.0	41	211
EDKL-42L DN38	728.3805.942	38.5	33.0	42.7	52x2.0	86.0	28.5	60	470

passend zu Bohrungsform Y (60°), DIN 3863
 passend zu Bohrungsform W (24°), DIN 3861

suitable for bore type Y (60°), DIN 3863
 suitable for bore type W (24°), DIN 3861

su instalación en forma de taladro Y (60°),
 DIN 3863
 su instalación en forma de taladro W (24°),
 DIN 3861

60

D1=Rohr außen-Ø
 *=mit Drahtmutter

D1=tube outside diameter
 *=with wire nut

D1=Ø exterior del tubo
 *=con tuerca de alambre

Nippel mit Universal-Dichtkegel, 45° Bogen
Nipples with universal taper, 45° elbow
Espigas con junta cónica universal a 45°

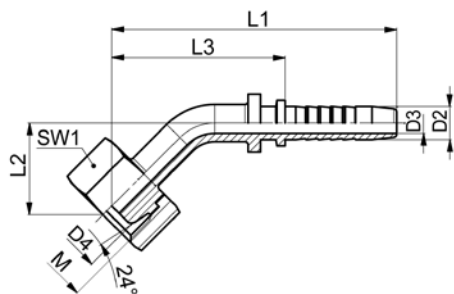

EDKL-45°

Type -D1 -DN	Mat.-Nr.	D2	D3	D4	M	L1	L2	L3	SW1	g/Stk
M=metrisches Gewinde (zylindrisch)		M=metric thread (parallel)				M=rosca métrica (cilindrica)				
* EDKL-06L DN06-45°	728.3815.106	6.5	4.0	7.3	12x1.5	70.5	18.0	43.5	14	28
EDKL-08L DN06-45°	728.3815.108	6.5	4.0	9.3	14x1.5	71.0	16.5	44.0	17	34
* EDKL-08L DN08-45°	728.3815.208	8.0	5.0	9.3	14x1.5	73.0	17.5	46.0	17	42
EDKL-10L DN06-45°	728.3815.110	6.5	4.0	11.5	16x1.5	71.5	16.0	44.5	19	40
EDKL-10L DN08-45°	728.3815.210	8.0	5.0	11.5	16x1.5	75.5	18.0	48.5	19	46
* EDKL-10L DN10-45°	728.3815.310	9.5	7.0	11.5	16x1.5	80.5	17.5	50.5	19	53
EDKL-12L DN06-45°	728.3815.112	6.5	4.0	13.5	18x1.5	73.0	14.5	46.0	22	50
EDKL-12L DN08-45°	728.3815.212	8.0	5.0	13.5	18x1.5	75.0	22.5	48.0	22	57
EDKL-12L DN10-45°	728.3815.312	9.5	7.0	13.5	18x1.5	81.0	17.0	51.0	22	59
EDKL-15L DN10-45°	728.3815.315	9.5	7.0	16.5	22x1.5	82.0	19.0	52.0	27	88
EDKL-15L DN12-45°	728.3815.415	13.0	9.5	16.5	22x1.5	94.0	25.0	62.0	27	116
EDKL-18L DN16-45°	728.3815.518	16.0	12.0	19.5	26x1.5	113.0	26.5	79.0	32	167
EDKL-22L DN19-45°	728.3815.620	19.0	15.0	23.1	30x2.0	114.0	30.0	75.0	36	250
EDKL-28L DN25-45°	728.3815.728	25.5	21.0	29.1	36x2.0	139.0	37.0	90.5	41	358
EDKL-35L DN31-45°	728.3815.835	32.0	27.0	35.7	45x2.0	202.0	60.5	146.5	50	676
EDKL-42L DN38-45°	728.3815.942	38.5	33.0	42.7	52x2.0	220.0	59.5	162.5	60	868

passend zu Bohrungsform Y (60°), DIN 3863
 passend zu Bohrungsform W (24°), DIN 3861

suitable for bore type Y (60°), DIN 3863
 suitable for bore type W (24°), DIN 3861

su instalación en forma de taladro Y (60°),
 DIN 3863
 su instalación en forma de taladro W (24°),
 DIN 3861

D1=Rohr außen-Ø
 *=mit Drahmutter

D1=tube outside diameter
 *=with wire nut

D1=Ø exterior del tubo
 *=con tuerca de alambre

Nippel mit Universal-Dichtkegel, 90° Bogen
Nipples with universal taper, 90° elbow
Espigas con junta cónica universal a 90°

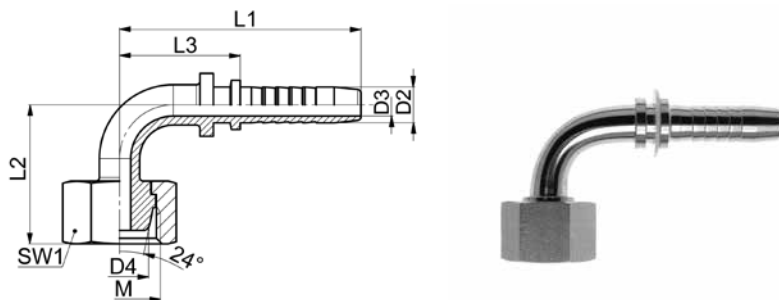

EDKL-90°

Type -D1 -DN	Mat.-Nr.	D2	D3	D4	M	L1	L2	L3	SW1	g/Stk
M=metrisches Gewinde (zylindrisch)		M=metric thread (parallel)				M=rosca métrica (cilindrica)				
* EDKL-06L DN06-90°	728.3825.106	6.5	4.0	7.3	12x1.5	52.5	31.5	25.5	14	28
EDKL-08L DN06-90°	728.3825.108	6.5	4.0	9.3	14x1.5	54.5	29.5	27.5	17	34
* EDKL-08L DN08-90°	728.3825.208	8.0	5.0	9.3	14x1.5	51.5	31.5	24.5	17	42
EDKL-10L DN06-90°	728.3825.110	6.5	4.0	11.5	16x1.5	57.5	29.5	30.5	19	40
EDKL-10L DN08-90°	728.3825.210	8.0	5.0	11.5	16x1.5	57.5	33.5	30.5	19	46
* EDKL-10L DN10-90°	728.3825.310	9.5	7.0	11.5	16x1.5	59.0	37.0	29.0	19	53
EDKL-12L DN06-90°	728.3825.112	6.5	4.0	13.5	18x1.5	63.5	27.5	36.5	22	50
EDKL-12L DN08-90°	728.3825.212	8.0	5.0	13.5	18x1.5	59.5	31.5	32.5	22	57
EDKL-12L DN10-90°	728.3825.312	9.5	7.0	13.5	18x1.5	61.0	34.0	31.0	22	59
EDKL-15L DN10-90°	728.3825.315	9.5	7.0	16.5	22x1.5	61.0	34.0	31.0	27	88
EDKL-15L DN12-90°	728.3825.415	13.0	9.5	16.5	22x1.5	67.0	38.0	35.0	27	116
EDKL-18L DN16-90°	728.3825.518	16.0	12.0	19.5	26x1.5	84.5	51.5	50.5	32	167
EDKL-22L DN19-90°	728.3825.620	19.0	15.0	23.1	30x2.0	88.0	54.0	49.0	36	250
EDKL-28L DN25-90°	728.3825.728	25.5	21.0	29.1	36x2.0	107.0	63.0	59.0	41	347
EDKL-35L DN31-90°	728.3825.835	32.0	27.0	35.7	45x2.0	149.5	98.5	94.0	50	676
EDKL-42L DN38-90°	728.3825.942	38.5	33.0	42.7	52x2.0	159.5	107.5	102.0	60	868

passend zu Bohrungsform Y (60°), DIN 3863
 passend zu Bohrungsform W (24°), DIN 3861

suitable for bore type Y (60°), DIN 3863
 suitable for bore type W (24°), DIN 3861

su instalación en forma de taladro Y (60°),
 DIN 3863
 su instalación en forma de taladro W (24°),
 DIN 3861

D1=Rohr außen-Ø
 *=mit Drahtmutter

D1=tube outside diameter
 *=with wire nut

D1=Ø exterior del tubo
 *=con tuerca de alambre

Nippel mit Dichtkegel, gerade

für Gegenanschluss mit 60° Konus

Nipples with taper, straight

for fittings with 60° taper

Espigas con junta cónica rectas

para conector con cono de 60°

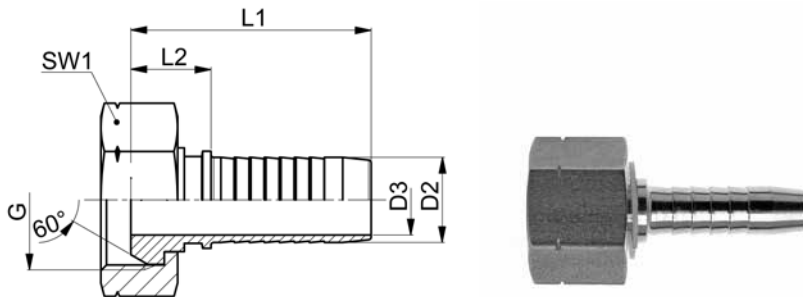

EDKR

Type-G-DN	Mat.-Nr.	D2	D3	G	L1	L2	SW1	g/Stk
G=Rohrgewinde (zylindrisch)		G=BSP thread (parallel)		G=rosca de conexión (cilíndrica)				
* EDKR-G 1.8 DN06	728.3505.106	6.5	3.0	1/8	44.0	17.0	14	21
EDKR-G 1.4 DN06	728.3505.108	6.5	4.0	1/4	44.0	17.0	17	28
EDKR-G 3.8 DN06	728.3505.110	6.5	4.0	3/8	45.0	18.0	22	47
* EDKR-G 1.4 DN08	728.3505.208	8.0	5.0	1/4	44.0	17.0	17	29
EDKR-G 3.8 DN08	728.3505.210	8.0	5.0	3/8	45.0	18.0	22	51
* EDKR-G 3.8 DN10	728.3505.310	9.5	7.0	3/8	51.0	21.0	22	58
EDKR-G 1.2 DN10	728.3505.312	9.5	7.0	1/2	49.0	19.0	24	58
* EDKR-G 3.8 DN12	728.3505.410	13.0	9.5	3/8	54.0	22.0	22	67
* EDKR-G 1.2 DN12	728.3505.412	13.0	9.5	1/2	54.0	22.0	24	75
EDKR-G 5.8 DN12	728.3505.415	13.0	9.5	5/8	50.0	18.0	27	113
EDKR-G 3.4 DN12	728.3505.414	13.0	9.5	3/4	51.0	19.0	32	79
* EDKR-G 1.2 DN16	728.3505.512	16.0	12.0	1/2	57.0	23.0	24	82
* EDKR-G 5.8 DN16	728.3505.513	16.0	12.0	5/8	57.0	23.0	27	103
EDKR-G 3.4 DN16	728.3505.514	16.0	12.0	3/4	57.0	23.0	32	128
* EDKR-G 3.4 DN19	728.3505.614	19.0	15.0	3/4	64.0	25.0	32	148
EDKR-G 1.1 DN19	728.3505.625	19.0	15.0	1	61.0	22.0	41	214
* EDKR-G 1.1 DN25	728.3505.725	25.5	21.0	1	75.0	27.0	41	260
EDKR-G 5.4 DN25	728.3505.728	25.5	21.0	1 1/4	72.0	24.0	50	338
* EDKR-G 5.4 DN31	728.3505.828	32.0	27.0	1 1/4	80.0	24.5	50	392
* EDKR-G 5.4 DN38	728.3505.928	38.5	27.0	1 1/4	86.0	28.5	50	463
* EDKR-G 3.2 DN38	728.3505.930	38.5	33.0	1 1/2	83.0	25.5	55	472
EDKR-G 4.2 DN38	728.3505.942	38.5	33.0	2	89.0	31.5	70	818
* EDKR-G 4.2 DN51	728.3505.042	50.5	44.5	2	106.0	31.0	70	880

*=mit Drahtmutter

*=with wire nut

*=con tuerca de alambre

Nippel mit Dichtkegel, 45° Bogen

für Gegenanschluss mit 60° Konus

Nipples with taper, 45° elbow

for fittings with 60° taper

Espigas con junta cónica a 45°

para conector con cono de 60°

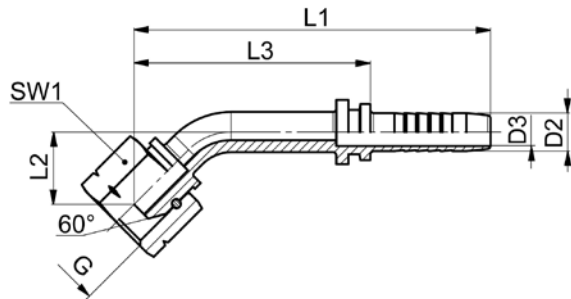

EDKR-45°

Type-G-DN	Mat.-Nr.	D2	D3	G	L1	L2	L3	SW1	g/Stk
G=Rohrgewinde (zylindrisch)		G=BSP thread (parallel)			G=rosca de conexión (cilíndrica)				
EDKR-G 1.4 DN06-45°	728.3515.108	6.5	4.0	1/4	74.5	15.0	47.5	17	33
EDKR-G 3.8 DN06-45°	728.3515.110	6.5	4.0	3/8	75.5	16.0	48.5	22	55
EDKR-G 3.8 DN08-45°	728.3515.210	8.0	5.0	3/8	77.5	18.0	50.5	22	61
* EDKR-G 3.8 DN10-45°	728.3515.310	9.5	7.0	3/8	86.5	23.5	56.5	22	74
EDKR-G 1.2 DN10-45°	728.3515.312	9.5	7.0	1/2	85.0	22.0	55.0	24	99
* EDKR-G 1.2 DN12-45°	728.3515.412	13.0	9.5	1/2	98.0	28.0	66.0	24	114
* EDKR-G 5.8 DN16-45°	728.3515.513	16.0	12.0	5/8	106.5	28.0	72.5	27	169
EDKR-G 3.4 DN16-45°	728.3515.514	16.0	12.0	3/4	108.5	28.0	74.5	32	197
* EDKR-G 3.4 DN19-45°	728.3515.614	19.0	15.0	3/4	138.5	33.5	99.5	32	252
EDKR-G 1.1 DN19-45°	728.3515.625	19.0	15.0	1	120.5	27.5	81.5	41	322
* EDKR-G 1.1 DN25-45°	728.3515.725	25.5	21.0	1	152.5	40.5	104.5	41	396
* EDKR-G 5.4 DN31-45°	728.3515.828	32.0	27.0	1 1/4	243.5	78.0	188.0	50	730
* EDKR-G 3.2 DN38-45°	728.3515.930	38.5	33.0	1 1/2	274.0	88.5	216.5	55	905
* EDKR-G 4.2 DN51-45°	728.3515.042	50.5	44.5	2	311.0	83.0	236.0	70	1949

60

*=mit Drahtmutter

*=with wire nut

*=con tuerca de alambre

Nippel mit Dichtkegel, 90° Bogen

für Gegenanschluss mit 60° Konus

Nipples with taper, 90° elbow

for fittings with 60° taper

Espigas con junta cónica a 90°

para conector con cono de 60°

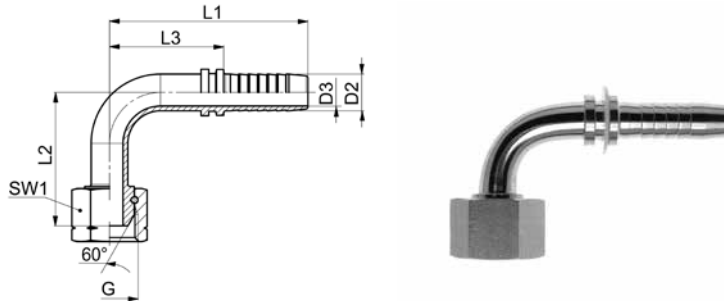

EDKR-90°

Type-G-DN	Mat.-Nr.	D2	D3	G	L1	L2	L3	SW1	g/Stk
G=Rohrgewinde (zylindrisch)	G=BSP thread (parallel)	G=rosca de conexión (cilíndrica)							
EDKR-G 1.4 DN06-90°	728.3525.108	6.5	4.0	1/4	53.5	26.5	26.5	17	33
EDKR-G 3.8 DN06-90°	728.3525.110	6.5	4.0	3/8	57.5	30.5	30.5	22	55
EDKR-G 3.8 DN08-90°	728.3525.210	8.0	5.0	3/8	58.5	31.5	31.5	22	61
* EDKR-G 3.8 DN10-90°	728.3525.310	9.5	7.0	3/8	60.0	42.0	30.0	22	74
EDKR-G 1.2 DN10-90°	728.3525.312	9.5	7.0	1/2	62.0	40.0	32.0	24	99
* EDKR-G 1.2 DN12-90°	728.3525.412	13.0	9.5	1/2	68.0	51.0	36.0	24	114
* EDKR-G 5.8 DN16-90°	728.3525.513	16.0	12.0	5/8	81.5	47.5	47.5	27	169
EDKR-G 3.4 DN16-90°	728.3525.514	16.0	12.0	3/4	82.5	48.5	48.5	32	197
* EDKR-G 3.4 DN19-90°	728.3525.614	19.0	15.0	3/4	101.0	63.0	62.0	32	252
EDKR-G 1.1 DN19-90°	728.3525.625	19.0	15.0	1	93.0	54.0	54.0	41	322
* EDKR-G 1.1 DN25-90°	728.3525.725	25.5	21.0	1	116.0	68.0	68.0	41	396
* EDKR-G 5.4 DN31-90°	728.3525.828	32.0	27.0	1 1/4	175.5	120.5	120.0	50	730
* EDKR-G 3.2 DN38-90°	728.3525.930	38.5	33.0	1 1/2	172.5	117.5	115.0	55	905
* EDKR-G 4.2 DN51-90°	728.3525.042	50.5	44.5	2	237.0	162.0	162.0	70	1949

*=mit Drahtmutter

*=with wire nut

*=con tuerca de alambre

Nippel mit Dichtkegel und O-Ring, gerade

für Gegenanschluss mit 24° Konus

Nipples with taper and O-ring, straight

for fittings with 24° taper

Espigas con junta cónica y junta tórica rectas

para conector con cono de 24°

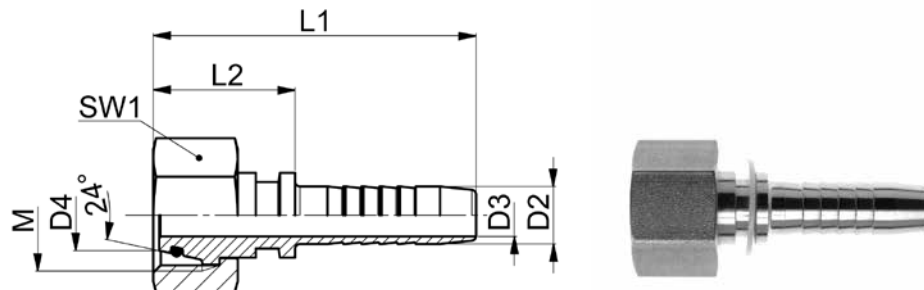

EDKOL/EDKOS

Type-D1 -DN	Mat.-Nr.	D2	D3	D4	M	L1	L2	SW1	g/Stk
M=metrisches Gewinde (zylindrisch)	M=metric thread (parallel)	M=rosca métrica (cilíndrica)							
* EDKOL-06L DN06	728.3905.106	6.5	2.5	5.7	12x1.5	49.0	22.0	14	24
EDKOL-08L DN06	728.3905.108	6.5	4.0	7.7	14x1.5	48.0	21.0	17	30
EDKOL-10L DN06	728.3905.110	6.5	4.0	9.7	16x1.5	48.0	21.0	19	34
EDKOL-10L DN08	728.3905.210	8.0	5.0	9.7	16x1.5	48.0	21.0	19	36
* EDKOL-10L DN10	728.3905.310	9.5	7.0	9.7	16x1.5	53.5	23.5	19	46
EDKOL-12L DN06	728.3905.112	6.5	4.0	11.7	18x1.5	48.0	21.0	22	44
EDKOL-12L DN08	728.3905.212	8.0	5.0	11.7	18x1.5	48.0	21.0	22	47
EDKOL-12L DN10	728.3905.312	9.5	7.0	11.7	18x1.5	52.5	22.5	22	51
* EDKOL-12L DN12	728.3905.412	13.0	9.5	11.7	18x1.5	56.0	24.0	22	64
EDKOL-15L DN10	728.3905.315	9.5	7.0	14.7	22x1.5	52.5	22.5	27	70
EDKOL-15L DN12	728.3905.415	13.0	9.5	14.7	22x1.5	54.5	22.5	27	76
EDKOL-18L DN12	728.3905.418	13.0	9.5	17.7	26x1.5	54.5	22.5	32	98
EDKOL-18L DN16	728.3905.518	16.0	12.0	17.7	26x1.5	55.5	21.5	32	106
EDKOL-22L DN16	728.3905.522	16.0	12.0	21.7	30x2.0	63.0	29.0	36	153
EDKOL-22L DN19	728.3905.622	19.0	15.0	21.7	30x2.0	63.0	24.0	36	149
EDKOL-28L DN25	728.3905.725	25.5	21.0	27.7	36x2.0	73.0	25.0	41	203
EDKOL-35L DN31	728.3905.835	32.0	27.0	34.7	45x2.0	82.5	27.0	50	309
EDKOL-42L DN38	728.3905.942	38.5	33.0	41.7	52x2.0	84.5	27.0	60	449
EDKOS-08S DN06	728.3935.108	6.5	4.0	7.7	16x1.5	47.5	20.5	19	34
EDKOS-10S DN06	728.3935.110	6.5	4.0	9.7	18x1.5	48.0	21.0	22	45
EDKOS-10S DN08	728.3935.210	8.0	5.0	9.7	18x1.5	48.0	21.0	22	47
EDKOS-12S DN08	728.3935.212	8.0	5.0	11.7	20x1.5	48.0	21.0	24	54
EDKOS-12S DN10	728.3935.312	9.5	7.0	11.7	20x1.5	51.5	21.5	24	61
EDKOS-14S DN10	728.3935.314	9.5	7.0	13.7	22x1.5	51.5	21.5	27	69
EDKOS-16S DN12	728.3935.416	13.0	9.5	17.7	24x1.5	53.5	21.5	30	88
EDKOS-20S DN12	728.3935.420	13.0	9.5	19.7	30x2.0	57.5	25.5	36	138
EDKOS-20S DN16	728.3935.520	16.0	12.0	19.7	30x2.0	59.5	25.5	36	146
EDKOS-20S DN19	728.3935.620	19.0	15.0	19.7	30x2.0	64.5	25.5	36	153
* EDKOS-20S DN25	728.3935.720	25.5	21.0	19.7	30x2.0	78.5	30.5	36	219
EDKOS-25S DN19	728.3935.625	19.0	15.0	24.7	36x2.0	64.5	25.5	41	182
EDKOS-30S DN25	728.3935.730	25.5	21.0	29.7	42x2.0	74.5	26.5	50	325
EDKOS-38S DN31	728.3935.838	32.0	27.0	37.7	52x2.0	82.5	27.0	60	420

Dichtungsmaterial: FKM (andere Werkstoffe auf Anfrage)

Sealing material: FKM (other materials on request)

Material de junta tórica: FKM (otros materiales bajo demanda)

D1=Rohr außen-Ø
*=mit Drahtmutter

D1=tube outside diameter
*=with wire nut

D1=Ø exterior del tubo
*=con tuerca de alambre

Nippel mit Dichtkegel und O-Ring, 45° Bogen

für Gegenanschluss mit 24° Konus

Nipples with taper and O-ring, 45° elbow

for fittings with 24° taper

Espigas con junta cónica y junta tórica a 45°

para conector con cono de 24°

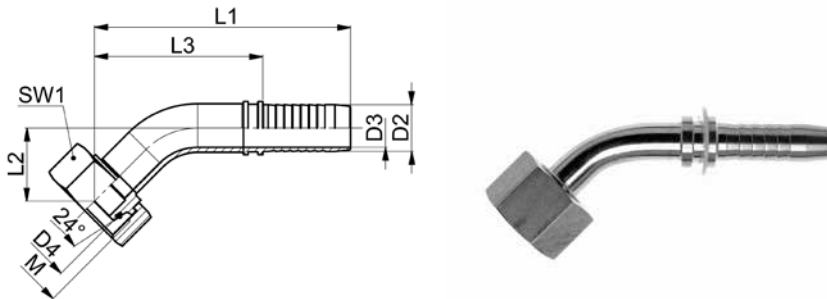

EDKOL/EDKOS-45°

Type-D1 -DN	Mat.-Nr.	D2	D3	D4	M	L1	L2	L3	SW1	g/Stk
M=metrisches Gewinde (zylindrisch)	M=metric thread (parallel)	M=rosca métrica (cilíndrica)								
* EDKOL-06L DN06-45°	728.3915.106	6.5	2.5	5.7	12x1.5	71.0	18.5	44.0	14	28
EDKOL-08L DN06-45°	728.3915.108	6.5	4.0	7.7	14x1.5	72.0	17.5	45.0	17	34
EDKOL-10L DN06-45°	728.3915.110	6.5	4.0	9.7	16x1.5	72.5	19.0	45.5	19	42
EDKOL-10L DN08-45°	728.3915.210	8.0	5.0	9.7	16x1.5	79.5	19.0	52.5	19	47
* EDKOL-10L DN10-45°	728.3915.310	9.5	7.0	9.7	16x1.5	81.5	21.5	51.5	19	53
EDKOL-12L DN10-45°	728.3915.312	9.5	7.0	11.7	18x1.5	80.5	20.5	50.5	22	61
* EDKOL-12L DN12-45°	728.3915.412	13.0	8.0	11.7	18x1.5	97.5	29.5	65.5	22	95
EDKOL-15L DN10-45°	728.3915.315	9.5	7.0	14.7	22x1.5	79.5	22.5	49.5	27	88
EDKOL-15L DN12-45°	728.3915.415	13.0	9.5	14.7	22x1.5	98.5	27.5	66.5	27	118
EDKOL-18L DN12-45°	728.3915.418	13.0	9.5	17.7	26x1.5	96.5	26.5	64.5	32	136
EDKOL-18L DN16-45°	728.3915.518	16.0	12.0	17.7	26x1.5	115.5	32.0	81.5	32	169
EDKOL-22L DN19-45°	728.3915.622	19.0	15.0	21.7	30x2.0	137.0	36.0	98.0	36	240
EDKOL-28L DN25-45°	728.3915.725	25.5	21.0	27.7	36x2.0	148.0	45.0	100.0	41	336
EDKOL-35L DN31-45°	728.3915.835	32.0	27.0	34.7	45x2.0	189.5	56.0	134.0	50	638
EDKOL-42L DN38-45°	728.3915.942	38.5	33.0	41.7	52x2.0	263.0	88.5	205.5	60	853
EDKOS-08S DN06-45°	728.3945.108	6.5	4.0	7.7	16x1.5	74.0	17.5	47.0	19	38
EDKOS-10S DN06-45°	728.3945.110	6.5	4.0	9.7	18x1.5	75.5	18.0	48.5	22	50
EDKOS-10S DN08-45°	728.3945.210	8.0	5.0	9.7	18x1.5	79.5	20.0	52.5	22	58
EDKOS-12S DN08-45°	728.3945.212	8.0	5.0	11.7	20x1.5	77.5	21.0	50.5	24	70
EDKOS-12S DN10-45°	728.3945.312	9.5	7.0	11.7	20x1.5	85.5	22.5	55.5	24	73
EDKOS-14S DN10-45°	728.3945.314	9.5	7.0	13.7	22x1.5	86.0	23.0	56.0	27	86
EDKOS-16S DN12-45°	728.3945.416	13.0	9.5	15.7	24x1.5	98.5	28.5	66.5	30	143
EDKOS-20S DN16-45°	728.3945.520	16.0	12.0	19.7	30x2.0	120.0	28.5	86.0	36	210
EDKOS-25S DN19-45°	728.3945.625	19.0	15.0	24.7	36x2.0	139.0	40.0	100.0	41	278
EDKOS-30S DN25-45°	728.3945.730	25.5	21.0	29.7	42x2.0	159.5	36.5	111.5	50	465
EDKOS-38S DN31-45°	728.3945.838	32.0	27.0	37.7	52x2.0	201.0	66.5	145.5	60	717

Dichtungsmaterial: FKM (andere Werkstoffe auf Anfrage)

Sealing material: FKM (other materials on request)

Material de junta tórica: FKM (otros materiales bajo demanda)

D1=Rohr außen-Ø
*=mit Drahtmutter

D1=tube outside diameter
*=with wire nut

D1=Ø exterior del tubo
*=con tuerca de alambre

Nippel mit Dichtkegel und O-Ring, 90° Bogen

für Gegenanschluss mit 24° Konus

Nipples with taper and O-ring, 90° elbow

for fittings with 24° taper

Espigas con junta cónica y junta tórica a 90°

para conector con cono de 24°

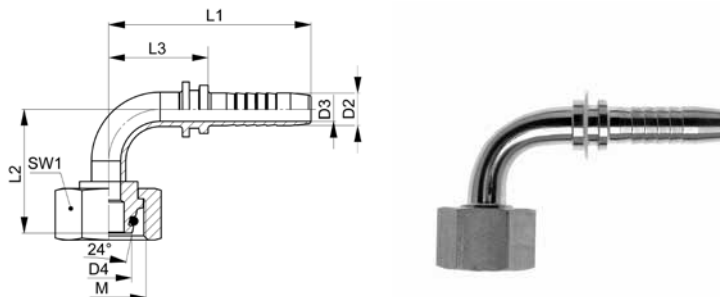

EDKOL/EDKOS-90°

Type-D1 -DN	Mat.-Nr.	D2	D3	D4	M	L1	L2	L3	SW1	g/Stk
M=metrisches Gewinde (zylindrisch)		M=metric thread (parallel)				M=rosca métrica (cilíndrica)				
* EDKOL-06L DN06-90°	728.3925.106	6.5	2.5	5.7	12x1.5	52.5	30.5	25.5	14	28
EDKOL-08L DN06-90°	728.3925.108	6.5	4.0	7.7	14x1.5	53.5	30.5	26.5	17	34
EDKOL-10L DN06-90°	728.3925.110	6.5	4.0	9.7	16x1.5	54.5	33.5	27.5	19	42
EDKOL-10L DN08-90°	728.3925.210	8.0	5.0	9.7	16x1.5	58.5	34.5	31.5	19	47
* EDKOL-10L DN10-90°	728.3925.310	9.5	7.0	9.7	16x1.5	59.0	38.0	29.0	19	53
EDKOL-12L DN10-90°	728.3925.312	9.5	7.0	11.7	18x1.5	60.0	38.0	30.0	22	61
* EDKOL-12L DN12-90°	728.3925.412	13.0	8.0	11.7	18x1.5	70.0	51.0	38.0	22	95
EDKOL-15L DN10-90°	728.3925.315	9.5	7.0	14.7	22x1.5	62.0	42.0	32.0	27	88
EDKOL-15L DN12-90°	728.3925.415	13.0	9.5	14.7	22x1.5	70.0	50.0	38.0	27	118
EDKOL-18L DN12-90°	728.3925.418	13.0	9.5	17.7	26x1.5	69.0	48.0	37.0	32	136
EDKOL-18L DN16-90°	728.3925.518	16.0	12.0	17.7	26x1.5	84.5	53.5	50.5	32	169
EDKOL-22L DN19-90°	728.3925.622	19.0	15.0	21.7	30x2.0	102.0	62.0	63.0	36	240
EDKOL-28L DN25-90°	728.3925.725	25.5	21.0	27.7	36x2.0	112.0	72.0	64.0	41	336
EDKOL-35L DN31-90°	728.3925.835	32.0	27.0	34.7	45x2.0	172.5	115.5	117.0	50	638
EDKOL-42L DN38-90°	728.3925.942	38.5	33.0	41.7	52x2.0	158.5	111.5	101.0	60	853
EDKOS-08S DN06-90°	728.3955.108	6.5	4.0	7.7	16x1.5	56.5	30.5	29.5	19	38
EDKOS-10S DN06-90°	728.3955.110	6.5	4.0	9.7	18x1.5	56.5	31.5	29.5	22	50
EDKOS-10S DN08-90°	728.3955.210	8.0	5.0	9.7	18x1.5	58.5	34.5	31.5	22	58
EDKOS-12S DN08-90°	728.3955.212	8.0	5.0	11.7	20x1.5	54.5	38.5	27.5	24	70
EDKOS-12S DN10-90°	728.3955.312	9.5	7.0	11.7	20x1.5	61.0	40.0	31.0	24	73
EDKOS-14S DN10-90°	728.3955.314	9.5	7.0	13.7	22x1.5	62.0	41.0	32.0	27	86
EDKOS-16S DN12-90°	728.3955.416	13.0	9.5	15.7	24x1.5	72.0	48.0	40.0	30	143
EDKOS-20S DN16-90°	728.3955.520	16.0	12.0	19.7	30x2.0	88.5	55.5	54.5	36	210
EDKOS-25S DN19-90°	728.3955.625	19.0	15.0	24.7	36x2.0	101.0	69.0	62.0	41	278
EDKOS-30S DN25-90°	728.3955.730	25.5	21.0	29.7	42x2.0	111.0	74.0	63.0	50	465
EDKOS-38S DN31-90°	728.3955.838	32.0	27.0	37.7	52x2.0	169.5	114.5	114.0	60	717

Dichtungsmaterial: FKM (andere Werkstoffe auf Anfrage)

Sealing material: FKM (other materials on request)

Material de junta tórica: FKM (otros materiales bajo demanda)

D1=Rohr außen-Ø
*=mit Drahtmutter

D1=tube outside diameter
*=with wire nut

D1=Ø exterior del tubo
*=con tuerca de alambre

60

Außengewinde-Nippel mit 24° Konus

für Rohrverschraubungen

Male adaptor nipples with 24° taper

for tube fittings

Espigas para roscar con cono de 24°

para racores de tubos

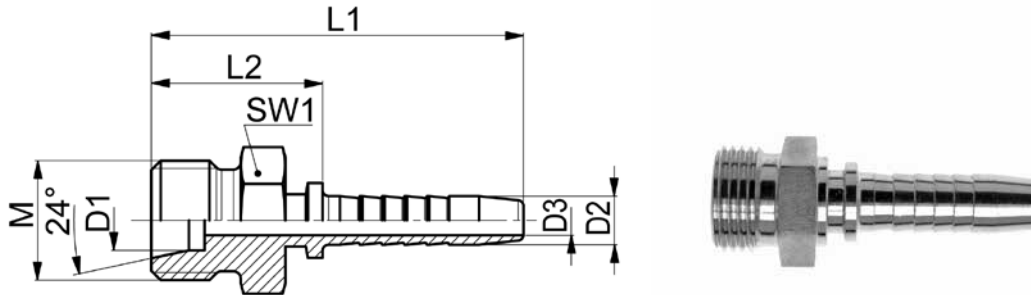

ECEL/ECES

Type-D1-DN	Mat.-Nr.	D2	D3	M	L1	L2	SW1	g/Stk
M=metrisches Gewinde (zylindrisch)	M=metric thread (parallel)	M=rosca métrica (cilíndrica)						
ECEL-06L DN06	726.6505.106	6.5	4.0	12x1.5	46.5	19.5	12	10
ECEL-08L DN06	726.6505.108	6.5	4.0	14x1.5	47.5	20.5	14	15
ECEL-10L DN06	726.6505.110	6.5	4.0	16x1.5	49.5	22.5	17	25
ECEL-10L DN08	726.6505.210	8.0	5.0	16x1.5	49.0	22.0	17	25
ECEL-10L DN10	726.6505.310	9.5	7.0	16x1.5	55.0	25.0	17	32
ECEL-12L DN06	726.6505.112	6.5	4.0	18x1.5	49.0	22.0	19	30
ECEL-12L DN08	726.6505.212	8.0	5.0	18x1.5	49.0	22.0	19	30
ECEL-12L DN10	726.6505.312	9.5	7.0	18x1.5	52.5	22.5	19	35
ECEL-15L DN10	726.6505.315	9.5	7.0	22x1.5	54.5	24.5	22	50
ECEL-15L DN12	726.6505.415	13.0	9.5	22x1.5	56.5	24.5	22	55
ECEL-18L DN12	726.6505.418	13.0	9.5	26x1.5	57.5	25.5	27	80
ECEL-18L DN16	726.6505.518	16.0	12.0	26x1.5	59.5	25.5	27	85
ECEL-22L DN19	726.6505.622	19.0	15.0	30x2.0	68.0	29.0	32	125
ECEL-28L DN25	726.6505.728	25.5	21.0	36x2.0	79.0	31.0	36	175
ECEL-35L DN31	726.6505.835	32.0	27.0	45x2.0	91.0	35.5	46	310
ECEL-42L DN38	726.6505.942	38.5	33.0	52x2.0	96.0	38.5	55	460
ECES-08S DN06	726.6605.108	6.5	4.0	16x1.5	50.0	23.0	17	30
ECES-10S DN06	726.6605.110	6.5	4.0	18x1.5	50.0	23.0	19	35
ECES-10S DN08	726.6605.210	8.0	5.0	18x1.5	50.0	23.0	19	35
ECES-10S DN10	726.6605.310	9.5	7.0	18x1.5	53.5	23.5	19	35
ECES-12S DN08	726.6605.212	8.0	5.0	20x1.5	51.0	24.0	22	55
ECES-12S DN10	726.6605.312	9.5	7.0	20x1.5	54.5	24.5	22	50
ECES-14S DN10	726.6605.314	9.5	7.0	22x1.5	56.5	26.5	22	55
ECES-14S DN12	726.6605.414	13.0	9.5	22x1.5	58.5	26.5	22	65
ECES-16S DN12	726.6605.416	13.0	9.5	24x1.5	59.5	27.5	24	75
ECES-20S DN16	726.6605.520	16.0	12.0	30x2.0	64.5	30.5	30	125
ECES-20S DN19	726.6605.620	19.0	15.0	30x2.0	70.0	31.0	30	125
ECES-25S DN19	726.6605.625	19.0	15.0	36x2.0	73.0	34.0	41	125
ECES-25S DN25	726.6605.725	25.5	21.0	36x2.0	83.0	35.0	41	225
ECES-30S DN25	726.6605.730	25.5	21.0	42x2.0	87.0	39.0	46	320
ECES-38S DN31	726.6605.838	32.0	27.0	52x2.0	100.0	45.5	55	535

D1=Rohr außen-Ø

D1=tube outside diameter

D1=Ø exterior del tubo

Außengewinde-Nippel mit 60° Konus
Male adaptor nipples with 60° taper
Espigas para roscar cono de 60°

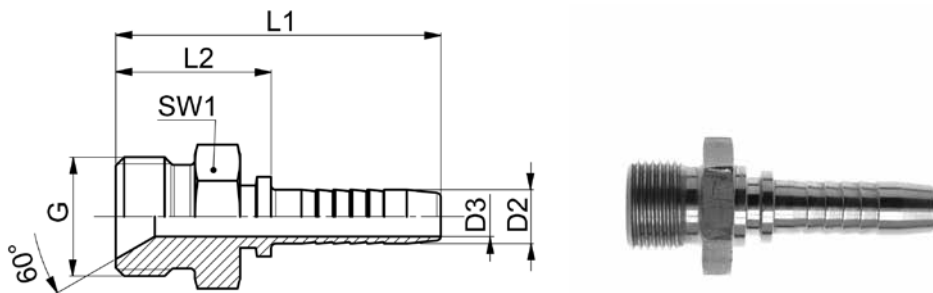

EAGR

Type-G-DN	Mat.-Nr.	D2	D3	G	L1	L2	SW1	g/Stk
G=Rohrgewinde (zylindrisch)		G=BSP thread (parallel)			G=rosca de conexión (cilíndrica)			
EAGR-G 1.8 DN06	726.6005.106	6.5	4.0	1/8	46.0	19.0	12	14
EAGR-G 1.4 DN06	726.6005.108	6.5	4.0	1/4	50.0	23.0	14	22
EAGR-G 3.8 DN06	726.6005.110	6.5	4.0	3/8	51.0	24.0	17	24
EAGR-G 1.4 DN08	726.6005.208	8.0	5.0	1/4	50.0	23.0	14	33
EAGR-G 3.8 DN08	726.6005.210	8.0	5.0	3/8	51.0	24.0	17	35
EAGR-G 3.8 DN10	726.6005.310	9.5	7.0	3/8	54.5	24.5	17	36
EAGR-G 1.2 DN10	726.6005.312	9.5	7.0	1/2	57.5	27.5	22	61
EAGR-G 1.2 DN12	726.6005.412	13.0	9.5	1/2	59.5	27.5	22	66
EAGR-G 5.8 DN16	726.6005.515	16.0	12.0	5/8	62.5	28.5	24	81
EAGR-G 3.4 DN16	726.6005.514	16.0	12.0	3/4	64.5	30.5	27	107
EAGR-G 3.4 DN19	726.6005.614	19.0	15.0	3/4	70.0	31.0	27	108
EAGR-G 1.1 DN19	726.6005.625	19.0	15.0	1	73.0	34.0	36	184
EAGR-G 1.1 DN25	726.6005.725	25.5	21.0	1	83.0	35.0	36	263
EAGR-G 5.4 DN25	726.6005.728	25.5	21.0	1 1/4	90.0	42.0	46	380
EAGR-G 5.4 DN31	726.6005.828	32.0	27.0	1 1/4	98.0	42.5	46	374
EAGR-G 3.2 DN31	726.6005.830	32.0	27.0	1 1/2	100.0	44.5	50	474
EAGR-G 3.2 DN38	726.6005.930	38.5	33.0	1 1/2	102.0	44.5	50	450
EAGR-G 4.2 DN51	726.6005.042	50.5	44.5	2	121.0	46.5	60	676

Außengewinde-Nippel BSPP
Male adaptor nipples BSPP
Espigas para roscar BSPP

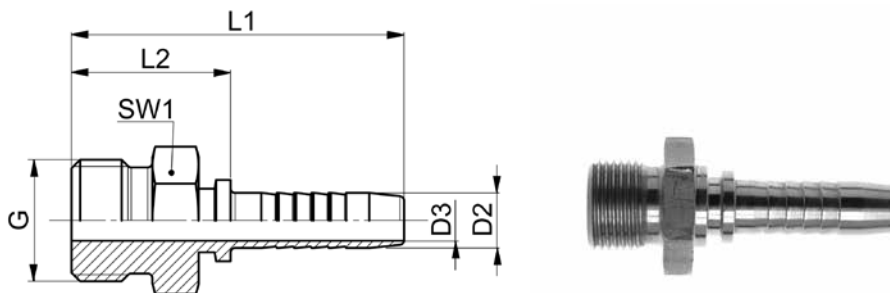

EAGF

Type -G -DN	Mat.-Nr.	D2	D3	G	L1	L2	SW1	g/Stk
G=Rohrgewinde (zylindrisch)		G=BSP thread (parallel)			G=rosca de conexión (cilíndrica)			
EAGF-G 1.4 DN06	726.6035.108	6.5	4.0	1/4	50.5	23.5	14	25
EAGF-G 3.8 DN08	726.6035.210	8.0	5.0	3/8	51.0	24.0	17	35
EAGF-G 3.8 DN10	726.6035.310	9.5	7.0	3/8	54.5	24.5	17	40
EAGF-G 1.2 DN10	726.6035.312	9.5	7.0	1/2	57.5	27.5	22	70
EAGF-G 1.2 DN12	726.6035.412	13.0	9.5	1/2	60.5	28.5	22	70
EAGF-G 5.8 DN16	726.6035.515	16.0	12.0	5/8	62.5	28.5	24	85
EAGF-G 3.4 DN19	726.6035.614	19.0	15.0	3/4	70.0	31.0	27	110
EAGF-G 1.1 DN19	726.6035.625	19.0	15.0	1	73.0	34.0	36	205
EAGF-G 1.1 DN25	726.6035.725	25.5	21.0	1	83.0	35.0	36	200
EAGF-G 5.4 DN25	726.6035.728	25.5	21.0	1 1/4	90.0	42.0	46	400
EAGF-G 5.4 DN31	726.6035.828	32.0	27.0	1 1/4	98.0	42.5	46	380
EAGF-G 3.2 DN38	726.6035.930	38.5	33.0	1 1/2	102.0	44.5	50	465
EAGF-G 4.2 DN51	726.6035.042	50.5	44.5	2	121.0	46.5	60	695

Außengewinde-Nippel BSPT

mit 60° Konus

Male adaptor nipples BSPT

with 60° taper

Espigas para roscar BSPT

con cono de 60°

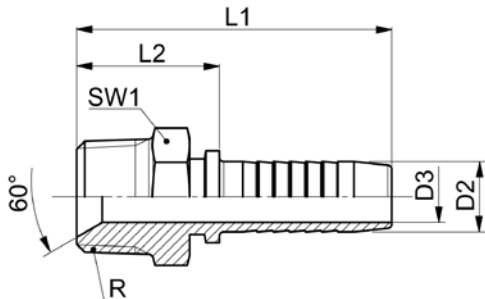

EAGK

Type -R -DN	Mat.-Nr.	D2	D3	R	L1	L2	SW1	g/Stk
R=Rohrgewinde (kegelig)		R=BSP thread (tapered)			R=rosca para tubos (cónica)			
EAGK-R 1.4 DN06	726.6045.108	6.5	4.0	1/4	50.0	23.0	14	23
EAGK-R 3.8 DN08	726.6045.210	8.0	5.0	3/8	50.0	23.0	17	34
EAGK-R 3.8 DN10	726.6045.310	9.5	7.0	3/8	53.5	23.5	17	35
EAGK-R 1.2 DN10	726.6045.312	9.5	7.0	1/2	56.5	26.5	22	61
EAGK-R 1.2 DN12	726.6045.412	13.0	9.5	1/2	58.5	26.5	22	66
EAGK-R 3.4 DN12	726.6045.414	13.0	9.5	3/4	62.5	30.5	27	107
EAGK-R 3.4 DN16	726.6045.514	16.0	12.0	3/4	63.5	29.5	27	107
EAGK-R 3.4 DN19	726.6045.614	19.0	15.0	3/4	70.0	31.0	27	112
EAGK-R 1.1 DN19	726.6045.625	19.0	15.0	1	73.0	34.0	36	192
EAGK-R 1.1 DN25	726.6045.725	25.5	21.0	1	83.0	35.0	36	199
EAGK-R 5.4 DN31	726.6045.828	32.0	27.0	1 1/4	95.0	39.5	46	351
EAGK-R 3.2 DN38	726.6045.930	38.5	33.0	1 1/2	102.0	44.5	50	460
EAGK-R 4.2 DN51	726.6045.042	50.5	44.5	2	121.0	46.5	60	685

Außengewinde-Nippel NPT

mit 60° Konus

Male adaptor nipples NPT

with 60° taper

Espigas para roscar NPT

con cono de 60°

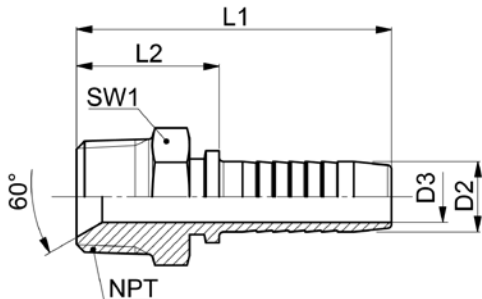

EAGN

Type-NPT-DN	Mat.-Nr.	D2	D3	NPT	L1	L2	SW1	g/Stk
NPT=Einschraubgewinde NPT		NPT=tapered male adaptor thread NPT			NPT=rosca de conexión cónica NPT			
EAGN-NPT 1.4 DN06	726.6055.108	6.5	4.0	1/4	52.0	25.0	14	24
EAGN-NPT 3.8 DN06	726.6055.110	6.5	4.0	3/8	52.0	25.0	17	35
EAGN-NPT 1.4 DN08	726.6055.208	8.0	5.0	1/4	52.0	25.0	14	25
EAGN-NPT 3.8 DN08	726.6055.210	8.0	5.0	3/8	52.0	25.0	17	36
EAGN-NPT 3.8 DN10	726.6055.310	9.5	7.0	3/8	55.5	25.5	17	37
EAGN-NPT 1.2 DN10	726.6055.312	9.5	7.0	1/2	61.5	31.5	22	67
EAGN-NPT 1.2 DN12	726.6055.412	13.0	9.5	1/2	63.5	31.5	22	71
EAGN-NPT 3.4 DN12	726.6055.414	13.0	9.5	3/4	65.5	33.5	27	113
EAGN-NPT 1.2 DN16	726.6055.512	16.0	12.0	1/2	65.5	31.5	22	73
EAGN-NPT 3.4 DN16	726.6055.514	16.0	12.0	3/4	67.5	33.5	27	115
EAGN-NPT 3.4 DN19	726.6055.614	19.0	15.0	3/4	73.0	34.0	27	114
EAGN-NPT 1.1 DN19	726.6055.625	19.0	15.0	1	80.0	41.0	36	219
EAGN-NPT 1.1 DN25	726.6055.725	25.5	21.0	1	90.0	42.0	36	213
EAGN-NPT 5.4 DN25	726.6055.728	25.5	21.0	1 1/4	93.0	45.0	46	377
EAGN-NPT 5.4 DN31	726.6055.828	32.0	27.0	1 1/4	101.0	45.5	46	367
EAGN-NPT 3.2 DN31	726.6055.830	32.0	27.0	1 1/2	101.0	45.5	50	465
EAGN-NPT 3.2 DN38	726.6055.930	38.5	33.0	1 1/2	106.0	48.5	50	471
EAGN-NPT 4.2 DN51	726.6055.042	50.5	44.5	2	124.0	49.5	60	684

Außengewinde-Nippel NPTF

mit 60° Konus

Male adaptor nipples NPTF

with 60° taper

Espigas para roscar NPTF

con cono de 60°

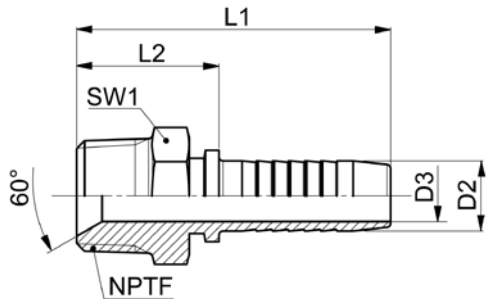

EAGNF

Type-NPTF-DN	Mat.-Nr.	D2	D3	NPTF	L1	L2	SW1	g/Stk
NPTF=Einschraubgewinde NPTF		NPTF=tapered male adaptor thread NPTF			NPTF=rosca de conexión cónica NPTF			
EAGNF-NPT F1.4 DN06	726.6015.108	6.5	4.0	1/4	52.0	25.0	14	25
EAGNF-NPT F3.8 DN08	726.6015.210	8.0	5.0	3/8	52.0	25.0	17	36
EAGNF-NPT F3.8 DN10	726.6015.310	9.5	7.0	3/8	55.5	25.5	17	37
EAGNF-NPT F1.2 DN10	726.6015.312	9.5	7.0	1/2	61.5	31.5	22	67
EAGNF-NPT F1.2 DN12	726.6015.412	13.0	9.5	1/2	63.5	31.5	22	71
EAGNF-NPT F3.4 DN16	726.6015.514	16.0	12.0	3/4	67.5	33.5	27	115
EAGNF-NPT F3.4 DN19	726.6015.614	19.0	15.0	3/4	73.0	34.0	27	114
EAGNF-NPT F1.1 DN25	726.6015.725	25.5	21.0	1	90.0	42.0	36	213
EAGNF-NPT F5.4 DN31	726.6015.828	32.0	27.0	1 1/4	101.0	45.5	46	367
EAGNF-NPT F3.2 DN38	726.6015.930	38.5	33.0	1 1/2	106.0	48.5	50	471
EAGNF-NPT F4.2 DN51	726.6015.042	50.5	44.5	2	124.0	49.5	60	684

Außengewinde-Nippel mit 74° JIC Konus
Male adaptor nipples with 74° JIC taper
Espigas para roscar con JIC cono de 74°

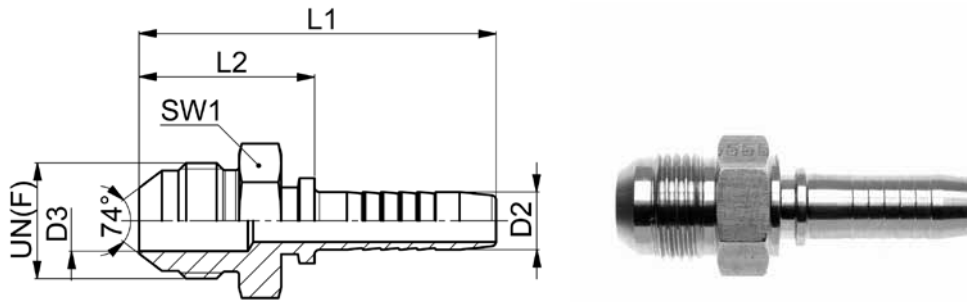

EAGJ

Type -UN(F) -DN	Mat.-Nr.	D2	D3	UNF	UN	L1	L2	SW1	g/Stk
UNF=Einschraubgewinde UNF				UNF=tapered adaptor thread UNF		UNF=rosca de conexión cónica UNF			
UN=Einschraubgewinde UN				UN=tapered adaptor thread UN		UN=rosca de conexión cónica UN			
EAGJ-UNF 7/16 DN06	726.6025.108	6.5	4.0	7/16	-	52.0	25.0	13	18
EAGJ-UNF 1/2 DN06	726.6025.112	6.5	4.0	1/2	-	52.0	25.0	14	20
EAGJ-UNF 9/16 DN06	726.6025.110	6.5	4.0	9/16	-	52.0	25.0	17	25
EAGJ-UNF 1/2 DN08	726.6025.212	8.0	5.0	1/2	-	52.0	25.0	14	23
EAGJ-UNF 9/16 DN08	726.6025.210	8.0	5.0	9/16	-	52.0	25.0	17	27
EAGJ-UNF 9/16 DN10	726.6025.310	9.5	7.0	9/16	-	55.5	25.5	17	29
EAGJ-UNF 3/4 DN10	726.6025.314	9.5	7.0	3/4	-	59.0	29.0	22	47
EAGJ-UNF 7/8 DN10	726.6025.316	9.5	7.0	7/8	-	63.0	33.0	24	67
EAGJ-UNF 3/4 DN12	726.6025.414	13.0	9.5	3/4	-	61.0	29.0	22	56
EAGJ-UNF 7/8 DN12	726.6025.416	13.0	9.5	7/8	-	65.0	33.0	24	75
EAGJ-UNF 7/8 DN16	726.6025.516	16.0	12.0	7/8	-	67.0	33.0	24	82
EAGJ-UN 1 1/16 DN16	726.6025.520	16.0	12.0	-	1 1/16	70.5	36.5	30	121
EAGJ-UN 1 1/16 DN19	726.6025.620	19.0	15.0	-	1 1/16	76.0	37.0	30	130
EAGJ-UN 1 5/16 DN19	726.6025.625	19.0	15.0	-	1 5/16	78.0	39.0	36	180
EAGJ-UN 1 1/16 DN25	726.6025.720	25.5	21.0	-	1 1/16	86.0	38.0	30	154
EAGJ-UN 1 5/16 DN25	726.6025.725	25.5	21.0	-	1 5/16	88.0	40.0	36	202
EAGJ-UN 1 5/8 DN25	726.6025.825	25.5	21.0	-	1 5/8	94.0	46.0	46	346
EAGJ-UN 1 5/8 DN31	726.6025.830	32.0	27.0	-	1 5/8	102.0	46.5	46	366
EAGJ-UN 1 7/8 DN38	726.6025.930	38.5	33.0	-	1 7/8	107.5	50.0	50	464
EAGJ-UN 2 1/2 DN51	726.6025.035	50.5	44.5	-	2 1/2	131.0	56.5	65	876

Nippel mit 74° JIC Konus, gerade
Nipples with 74° JIC taper, straight
Espigas con cono de 74° JIC rectas

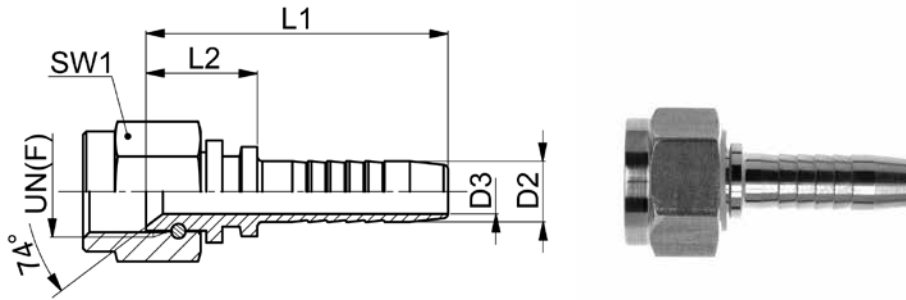

EDKJ

Type -UN(F) -DN	Mat.-Nr.	D2	D3	UNF	UN	L1	L2	SW1	g/Stk
UNF=Einschraubgewinde UNF				UNF=tapered adaptor thread UNF		UNF=rosca de conexión cónica UNF			
UN=Einschraubgewinde UN				UN=tapered adaptor thread UN		UN=rosca de conexión cónica UN			
* EDKJ-UNF 7/16 DN06	728.1065.108	6.5	4.0	7/16	-	43.5	16.5	17	49
* EDKJ-UNF 1/2 DN06	728.1065.112	6.5	4.0	1/2	-	43.5	16.5	19	42
EDKJ-UNF 9/16 DN06	728.1065.110	6.5	4.0	9/16	-	44.5	17.5	19	35
* EDKJ-UNF 1/2 DN08	728.1065.212	8.0	5.0	1/2	-	43.5	16.5	19	44
* EDKJ-UNF 9/16 DN08	728.1065.210	8.0	5.0	9/16	-	43.5	16.5	19	42
* EDKJ-UNF 9/16 DN10	728.1065.310	9.5	7.0	9/16	-	47.5	17.5	19	45
EDKJ-UNF 3/4 DN10	728.1065.314	9.5	7.0	3/4	-	49.5	19.5	24	63
* EDKJ-UNF 3/4 DN12	728.1065.414	13.0	9.5	3/4	-	50.5	18.5	24	77
EDKJ-UNF 7/8 DN12	728.1065.416	13.0	9.5	7/8	-	54.0	22.0	27	90
EDKJ-UN 1 1/16 DN12	728.1065.418	13.0	9.5	-	1 1/16	54.0	22.0	32	130
* EDKJ-UNF 7/8 DN16	728.1065.516	16.0	12.0	7/8	-	55.0	21.0	27	111
EDKJ-UN 1 1/16 DN16	728.1065.520	16.0	12.0	-	1 1/16	56.0	22.0	32	137
* EDKJ-UN 1 1/16 DN19	728.1065.620	19.0	15.0	-	1 1/16	60.5	21.5	32	156
* EDKJ-UN 1 1/16 DN25	728.1065.720	25.5	21.0	-	1 1/16	70.5	22.5	32	205
* EDKJ-UN 1 5/16 DN25	728.1065.725	25.5	21.0	-	1 5/16	70.5	22.5	38	269
* EDKJ-UN 1 5/8 DN31	728.1065.830	32.0	27.0	-	1 5/8	78.5	23.0	50	395
* EDKJ-UN 1 7/8 DN38	728.1065.932	38.5	33.0	-	1 7/8	80.5	23.0	60	599
EDKJ-UN 2 1/2 DN51	728.1065.035	50.5	44.5	-	2 1/2	98.5	24.0	70	793

60

*=mit Drahtmutter

*=with wire nut

*=con tuerca de alambre

Nippel mit 74° JIC Konus, 45° Bogen
Nipples with 74° JIC taper, 45° elbow
Espigas con cono de 74° JIC a 45°

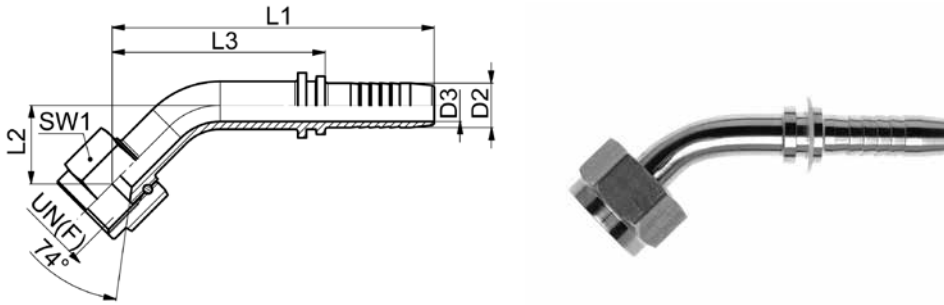

EDKJ-45°

Type -UN(F) -DN	Mat.-Nr.	D2	D3	UNF	UN	L1	L2	L3	SW1	g/Stk
UNF=Einschraubgewinde UNF				UNF=tapered adaptor thread UNF		UNF=rosca de conexión cónica UNF				
UN=Einschraubgewinde UN				UN=tapered adaptor thread UN		UN=rosca de conexión cónica UN				
* EDKJ-UNF 7/16 DN06-45°	728.1075.108	6.5	4.0	7/16	-	65.5	16.0	38.5	17	39
* EDKJ-UNF 1/2 DN06-45°	728.1075.112	6.5	4.0	1/2	-	66.5	15.5	39.5	19	45
EDKJ-UNF 9/16 DN06-45°	728.1075.110	6.5	4.0	9/16	-	72.5	16.0	45.5	19	42
* EDKJ-UNF 1/2 DN08-45°	728.1075.212	8.0	5.0	1/2	-	72.5	17.5	45.5	19	52
* EDKJ-UNF 9/16 DN08-45°	728.1075.210	8.0	5.0	9/16	-	71.5	18.0	44.5	19	50
* EDKJ-UNF 9/16 DN10-45°	728.1075.310	9.5	7.0	9/16	-	75.0	19.5	45.0	19	54
EDKJ-UNF 3/4 DN10-45°	728.1075.314	9.5	7.0	3/4	-	80.0	21.0	50.0	24	72
* EDKJ-UNF 3/4 DN12-45°	728.1075.414	13.0	9.5	3/4	-	93.0	27.0	61.0	24	104
EDKJ-UNF 7/8 DN12-45°	728.1075.416	13.0	9.5	7/8	-	103.0	35.0	71.0	27	128
* EDKJ-UNF 7/8 DN16-45°	728.1075.516	16.0	12.0	7/8	-	108.5	35.5	74.5	27	158
EDKJ-UN 1 1/16 DN16-45°	728.1075.520	16.0	12.0	-	1 1/16	115.5	41.0	81.5	32	196
* EDKJ-UN 1 1/16 DN19-45°	728.1075.620	19.0	15.0	-	1 1/16	127.0	38.5	88.0	32	230
* EDKJ-UN 1 5/16 DN25-45°	728.1075.725	25.5	21.0	-	1 5/16	160.0	35.0	112.0	38	342
* EDKJ-UN 1 5/8 DN31-45°	728.1075.830	32.0	27.0	-	1 5/8	221.5	75.0	166.0	50	779
* EDKJ-UN 1 7/8 DN38-45°	728.1075.932	38.5	33.0	-	1 7/8	242.5	82.5	185.0	60	1121
EDKJ-UN 2 1/2 DN51-45°	728.1075.035	50.5	44.5	-	2 1/2	317.0	115.5	242.5	70	1965

*=mit Drahtmutter

*=with wire nut

*=con tuerca de alambre

Nippel mit 74° JIC Konus, 90° Bogen
Nipples with 74° JIC taper, 90° elbow
Espigas con cono de 74° JIC a 90°

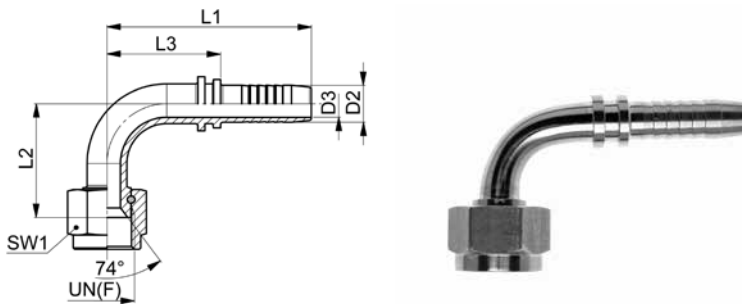

EDKJ-90°

Type -UN(F) -DN	Mat.-Nr.	D2	D3	UNF	UN	L1	L2	L3	SW1	g/Stk
UNF=Einschraubgewinde UNF		UNF=tapered adaptor thread UNF				UNF=rosca de conexión cónica UNF				
UN=Einschraubgewinde UN		UN=tapered adaptor thread UN				UN=rosca de conexión cónica UN				
* EDKJ-UNF 7/16 DN06-90°	728.1085.108	6.5	4.0	7/16	-	52.5	25.5	25.5	17	39
* EDKJ-UNF 1/2 DN06-90°	728.1085.112	6.5	4.0	1/2	-	52.5	25.5	25.5	19	45
EDKJ-UNF 9/16 DN06-90°	728.1085.110	6.5	4.0	9/16	-	55.5	28.5	28.5	19	42
* EDKJ-UNF 1/2 DN08-90°	728.1085.212	8.0	5.0	1/2	-	53.5	28.5	26.5	19	52
* EDKJ-UNF 9/16 DN08-90°	728.1085.210	8.0	5.0	9/16	-	54.5	27.5	27.5	19	50
* EDKJ-UNF 9/16 DN10-90°	728.1085.310	9.5	7.0	9/16	-	60.0	30.0	30.0	19	54
EDKJ-UNF 3/4 DN10-90°	728.1085.314	9.5	7.0	3/4	-	60.0	35.0	30.0	24	72
* EDKJ-UNF 3/4 DN12-90°	728.1085.414	13.0	9.5	3/4	-	72.0	40.0	40.0	24	104
EDKJ-UNF 7/8 DN12-90°	728.1085.416	13.0	9.5	7/8	-	77.0	49.0	45.0	27	128
* EDKJ-UNF 7/8 DN16-90°	728.1085.516	16.0	12.0	7/8	-	84.5	50.5	50.5	27	158
EDKJ-UN 1 1/16 DN16-90°	728.1085.520	16.0	12.0	-	1 1/16	85.5	59.5	51.5	32	196
* EDKJ-UN 1 1/16 DN19-90°	728.1085.620	19.0	15.0	-	1 1/16	98.0	59.0	59.0	32	230
* EDKJ-UN 1 5/16 DN25-90°	728.1085.725	25.5	21.0	-	1 5/16	114.0	78.0	66.0	38	243
* EDKJ-UN 1 5/8 DN31-90°	728.1085.830	32.0	27.0	-	1 5/8	165.5	109.5	110.0	50	779
* EDKJ-UN 1 7/8 DN38-90°	728.1085.932	38.5	33.0	-	1 7/8	180.5	122.5	123.0	60	1121
EDKJ-UN 2 1/2 DN51-90°	728.1085.035	50.5	44.5	-	2 1/2	238.0	163.0	163.5	70	1965

60

*=mit Drahtmutter

*=with wire nut

*=con tuerca de alambre

Schlauch-Adapter

für dünnwandige Kunststoffrohre

Hose adaptors

for thin-walled flexible hoses

Adaptadores para tubos flexibles

para tubos flexibles de plástico de pared delgada

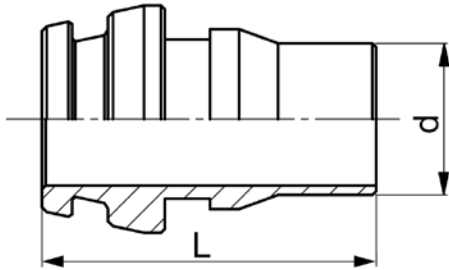

ESA

Type-D1	Mat.-Nr.	PN	d	M	L1	O-Ring	g/Stk
M=metrisches Gewinde (zylindrisch)	M=metric thread (parallel)	M=rosca métrica (cilindrica)					
ESA-06L04	708.0502.110.20	20	4.00	12x1.5	15.0	4.0x1.5	2
ESA-08L06	708.0502.140.20	20	6.00	14x1.5	15.0	6.0x1.5	2
ESA-10L08	708.0502.190.20	20	8.00	16x1.5	18.0	7.5x1.5	4
ESA-12L10	708.0502.240.20	20	10.00	18x1.5	19.5	9.0x1.5	5
ESA-15L12	708.0502.420.20	20	12.00	22x1.5	19.5	12.0x2.0	8

Passend für 24° Innenkonus

Dichtungsmaterial: FKM (andere Werkstoffe auf Anfrage)

For 24° conus connections

Sealing material: FKM (other materials on request)

Apto para cono interior de 24°

Material de junta tórica: FKM (otros materiales bajo demanda)

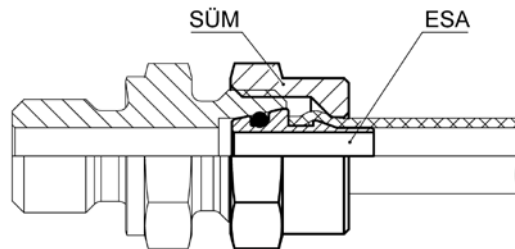

- Schlauch-Überwurfmutter (SÜM) mit der Schulter voran auf den Schlauch schieben
- Schlauch-Adapter (ESA) in den Schlauch drücken
- Mutter auf ein Verschraubungsgrundteil aufschrauben

Der Kunststoffschlauch wird zwischen Schulter der Mutter und Kegel des Adapters sicher geklemmt, die Verbindung dichtet mittels O-Ring.

- push the hose nut (SÜM) with the shoulder at the front onto the hose
- press the hose adapter (ESA) into the hose
- screw the nut onto the base part of the fitting

The plastic tube is securely clamped between the shoulder of the nut and the cone of the adaptor, the connection is sealed by the O-ring.

- empuja la tuerca de unión para tubos flexibles (SÜM) con el hombro en la parte delantera sobre la manguera
- presiona el adaptador para tubos flexibles (ESA) en la manguera
- enroscar la tuerca en la parte de la base del racor

El tubo de plástico se sujeta firmemente entre el hombro de la tuerca y el cono del adaptador, la conexión se sella con la junta tórica.

Schlauch-Überwurfmuttern

Hose nuts

Tuercas de unión para tubos flexibles

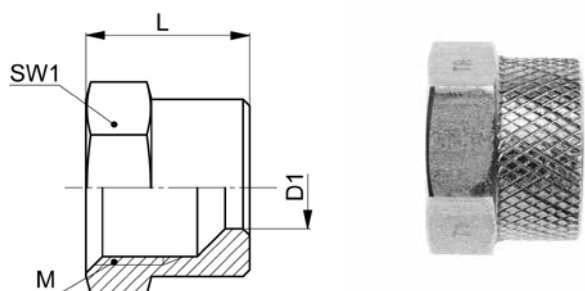

SÜM

Type -D1	Mat.-Nr.	PN	M	L	SW1	g/Stk
M=metrisches Gewinde (zylindrisch)	M=metric thread (parallel)			M=rosca métrica (cilindrica)		
SÜM-06L	706.0204.060.20	20	12x1.5	12.5	14	7
SÜM-08L	706.0204.080.20	20	14x1.5	12.5	17	12
SÜM-10L	706.0204.100.20	20	16x1.5	15.5	19	17
SÜM-12L	706.0204.120.20	20	18x1.5	15.5	22	23
SÜM-15L	706.0204.150.20	20	22x1.5	16.0	27	36

Zur Verwendung mit Schlauch-Adapter ESA

For use with hose adaptor ESA

Utilizar con adaptador para tubos flexibles ESA

Rohre, Schläuche

Tubes, hoses

Tubos, mangueras



Seite/Page/Página

Seite/Page/Página

Hydraulikschläuche
Hydraulic hoses
Mangueras hidráulicas

70.3-70.7



Perfluorethylenpropylen FEP
Fluorinated ethylene propylene FEP
Perfluoretileno/propileno FEP

70.19



Präzisionsrohre aus Edelstahl 1.4571
Stainless steel tubes 1.4571
Tubos de precisión de acero inoxidable 1.4571

70.9



Perfluoralkoxy-Rohr (PFA)
Perfluoroalkoxy tube (PFA)
Tubo de perfluoroalcoxi (PFA)

70.20



Präzisionsrohre aus Edelstahl 1.4301
Stainless steel tubes 1.4301
Tubos de precisión de acero inoxidable 1.4301

70.10



SERTOflex-Rohr
SERTOflex tube
Tubo SERTOflex

70.21



Polyamid-Rohr (PA)
Polyamide tube (PA)
Tubo de poliamida (PA)

70.11-70.12



Polyethylen-Rohr (LD-PE)
Polyethylene tube (LD-PE)
Tubo de polietileno (LD-PE)

70.13-70.14



Polyurethan-Rohr (PU)
Polyurethane tube (PU)
Tubo de poliuretano (PU)

70.15



Polytetrafluorethylen-Rohr (PTFE)
Polytetrafluorethylene tube (PTFE)
Tubo de politetrafluoroetileno (PTFE)

70.16-70.17



Polyvinylidenfluorid-Rohr (PVDF)
Polyvinylide fluoride tube (PVDF)
Tubo de polivinilidenfluoruro (PVDF)

70.18



Rohre, Schläuche

Tubes, Hoses

Tubos, Mangueras

Hydraulikschläuche

Hydraulic hoses

Mangueras hidráulicas

Schlauchtypen

Hose types

Tipo di manguera

Schlauch Hose Manguera	Typ Type Tipo	DIN	SAE
1 Drahteinlage mit dünner Außenschicht 1 wire inlet with thin covering 1 malla metálica con cubierta fina	1 SN	DIN EN 853	100 R 1 AT
2 Drahteinlagen mit dünner Außenschicht 2 wire inlets with thin covering 2 mallas metálicas con cubierta fina	2 SN	DIN EN 853	100 R 2 AT
1 Drahteinlage mit dünner Außenschicht 1 wire inlet with thin covering 1 malla metálica con cubierta fina	1 SC	DIN EN 857	
2 Drahteinlagen mit dünner Außenschicht 2 wire inlets with thin covering 2 mallas metálicas con cubierta fina	2 SC	DIN EN 857	
2 Textilgeflechte mit dünner Außenschicht 2 textile braids with thin covering 2 enrejados de textil con cubierta fina	2 TE	DIN EN 854	



Hydraulikschläuche

Hydraulic hoses

Mangueras hidráulicas

Hydraulikschläuche zeichnen sich durch Robustheit, Flexibilität sowie Korrosions- und Druckbeständigkeit aus. Lieferbar sind verschiedene Schläuchtypen mit Armaturen aus Edelstahl 1.4571 in unterschiedlichen Längen nach Kundenspezifikation.

Hydraulic hoses offer robustness, flexibility, corrosion and pressure resistance. Various hose types with fittings made of stainless steel 1.4571 are available in different lengths according to customer specifications.

Las mangueras hidráulicas se caracterizan por su robustez, su flexibilidad y su resistencia a la presión y a la corrosión. Suministramos distintos tipos de mangueras con conectores de acero inoxidable 1.4571 y diferentes longitudes adaptadas a las especificaciones del cliente.

Messbeispiele für die Nennlänge (NL) der konfektionierten Hydraulikschläuche:

Measuring examples for the nominal length (NL) of the assembled hydraulic hoses:

Ejemplos de medidas de longitud nominal (NL) de las mangueras hidráulicas con conector:

1. Schlaucharmaturen gerade

1. Hose couplings straight

1. Conectores de manguera rectos

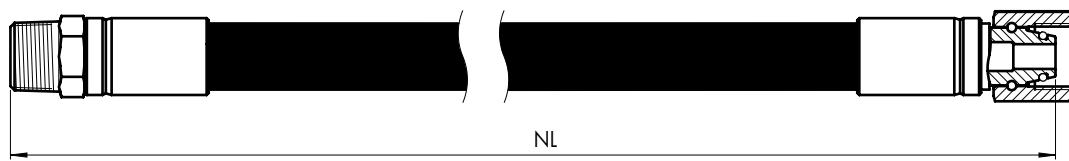

2. Schlaucharmaturen 45°

2. Hose couplings 45°

2. Conectores de manguera a 45°

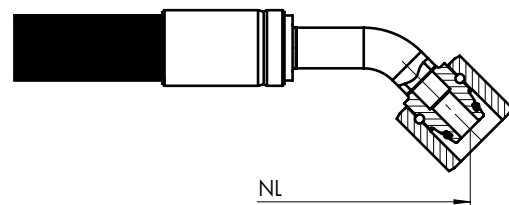
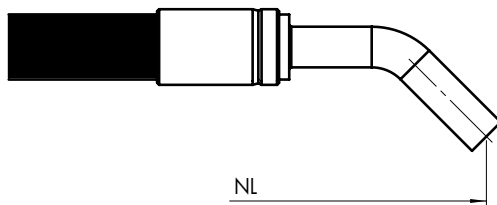

3. Schlaucharmaturen 90°

3. Hose couplings 90°

3. Conectores de manguera a 90°

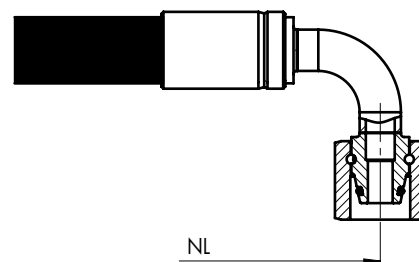
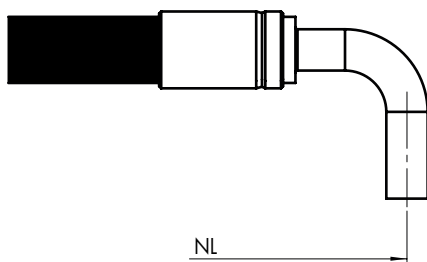

NL = Nennlänge des Schlauches gemäss Massbild

NL = Nominal length of tube as per drawing

NL = longitud nominal de la manguera según el plano acotado

4. Toleranzen

4. Tolerances

4. Tolerancias

NL	≤ DN25	> DN25
≤ 630 mm	+ 7 / - 3 mm	+ 12 / - 4 mm
> 630 - 1250 mm	+ 12 / - 4 mm	+ 20 / - 6 mm
> 1250 - 2500 mm	+ 20 / - 6 mm	+ 25 / - 6 mm
> 2500 - 8000 mm	+ 1.5 / - 0.5 %	
> 8000 mm	+ 3.0 / - 10.0 %	

Hydraulikschläuche

Hydraulic hoses

Mangueras hidráulicas

Verdrehwinkel bei gebogenen Armaturen

Werden an beiden Schlauchenden gebogene Armaturen eingesetzt, kann der Verdrehwinkel gewählt werden. Dieser wird, ausgehend vom 1. Anschluss, in Schritten von 45° im Gegenuhrzeigersinn definiert. Andere Verdrehwinkel auf Anfrage. Toleranz 3°.

Rotation angle for angled fittings

If angled fittings are used on both sides, the rotation angle can be selected. This is defined, starting from the 1. fitting, in steps of 45° counterclockwise. Tolerance 3°

Ángulo de giro en conectores acodados

Si en ambos extremos de la manguera se utilizan conectores acodados, el ángulo de giro podrá elegirse. Este se determina a intervalos de 45° en sentido antihorario, partiendo de la primera conexión. Existen otros ángulos de giro disponibles previa solicitud (tolerancia = 3°).

Beispiele:

Example:

Ejemplos:

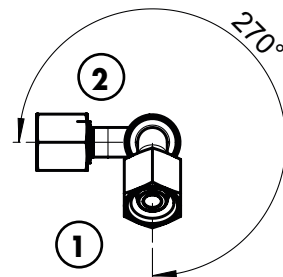
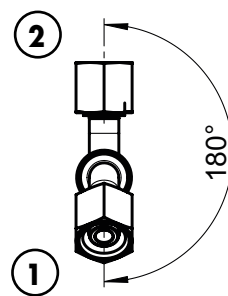
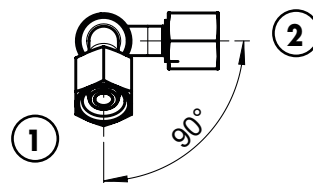
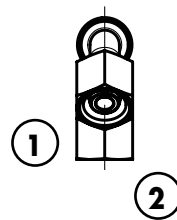
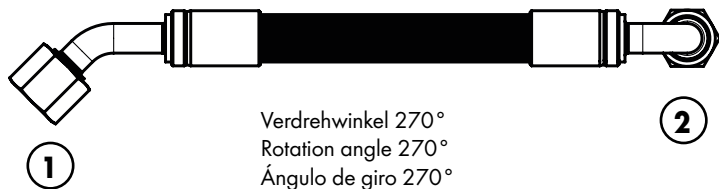
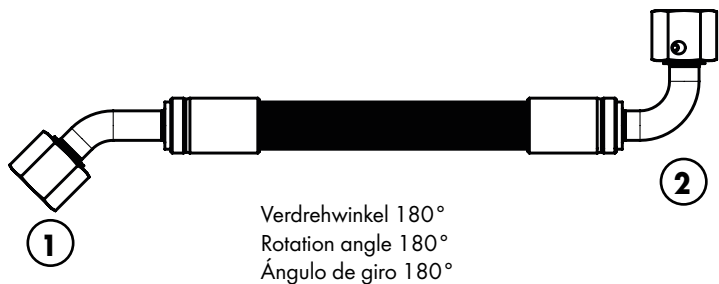
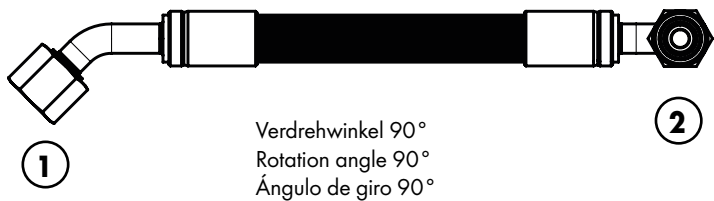
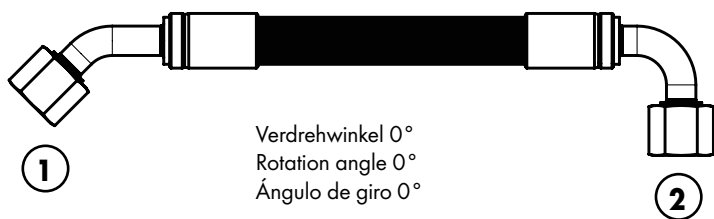

Hinweise zur Verlegung von Schlauchleitungen

Information on installing hose lines

Información de la instalación de mangueras

1. Keine Zugspannung

Schlauch leicht durchhängen lassen. Unter Belastung kann sich die Länge einer Schlauchleitung ändern. Eine Verkürzung bedeutet eine zusätzliche Zugspannung. Beachten Sie auch die für Hubbewegungen benötigte Schlauchlänge.

1. No tensile stress

Give the hose slightly additional slack. The length of a hose line can change under load. A shortening means additional tensile stress. Please also note the hose length required for lifting movements.

1. Evitar el esfuerzo de tracción

Deje que la manguera cuelgue ligeramente. La longitud de un conducto de manguera puede cambiar bajo presión. Un acortamiento de esta indica la existencia de un esfuerzo de tracción adicional. Tenga en cuenta además la longitud de manguera necesaria para los movimientos de elevación.

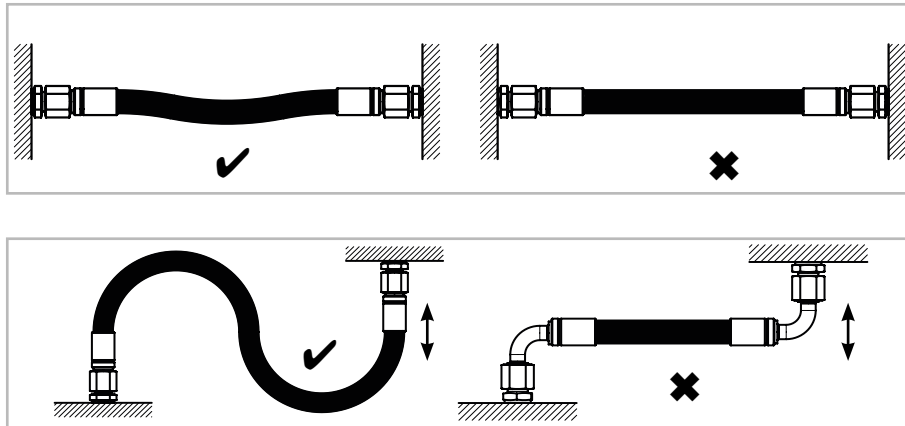

2. Keine Torsion

Schlauchleitung beim Einbau nicht verdrehen (keine Torsion).

2. No torsion

Do not distort the hose line during installation (no torsion).

2. Evitar la torsión

No distorsione la línea de la manguera durante la instalación (sin torsión).

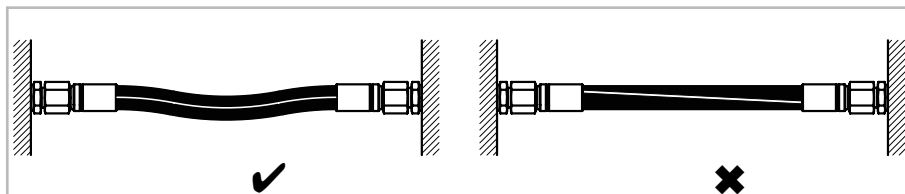

3. Keine Knicke

Bei gekrümmtem Einbau ist auf den zulässigen Biegeradius zu achten. Scharfe Knicke sind zu vermeiden. Beachten Sie bei der Bemessung der freien Schlauchlänge zwischen den Armaturen die Länge der Anschlussarmaturen.

3. No kinks

For curved installation, the permissible bending radius must be observed. Sharp kinks are to be avoided. When dimensioning the free hose length between the fittings, observe the length of the hose couplings.

3. Evitar dobleces

En caso de realizar un montaje curvilíneo, tenga en cuenta el radio de flexión autorizado. Deben evitarse las dobleces pronunciadas. Al calcular la longitud de manguera libre entre los conectores, tenga en cuenta la longitud de los racores de conexión.

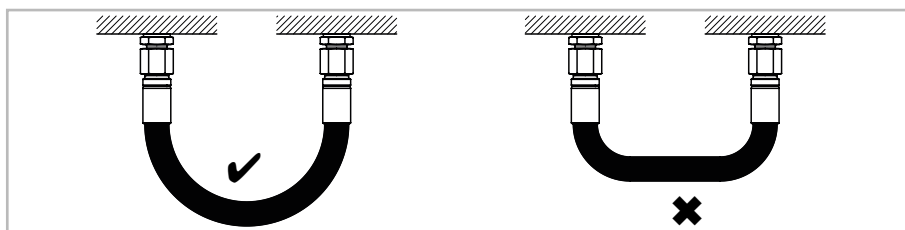

Hinweise zur Verlegung von Schlauchleitungen

Information on installing hose lines

Información de la instalación de mangueras

4. Richtige Armaturenwahl

Benutzen Sie gebogene Schlaucharmaturen. Ihr Radius ermöglicht auch bei beengten Einbauverhältnissen eine richtige Verlegung der Schlauchleitung. Gebogene Schlaucharmaturen sind auch dort angebracht, wo die Anordnung der Anschlüsse einen "hängenden" Bogen nicht zulässt und bei "stehenden" Bogen stets eine Knickgefahr hinter der Schlauchfassung besteht.

4. Correct choice of fittings

Use bent hose couplings. Their radius enables the hose line to be installed correctly even in tight spaces. Bent hose couplings are also used where the arrangement of the connections does not allow a "hanging" bend and where there is always a danger of kinking behind the hose fitting when the bend is "standing".

4. Elección correcta de los conectores

Utilice conectores de manguera acodados. El radio de estos permite tender correctamente el conducto de manguera aun en espacios reducidos. Los conectores de manguera acodados también son apropiados allí donde la disposición de las conexiones no admite la existencia de un arco "colgante" y el empleo de un arco "recto" provoca un riesgo de flexión constante tras el soporte de la manguera.

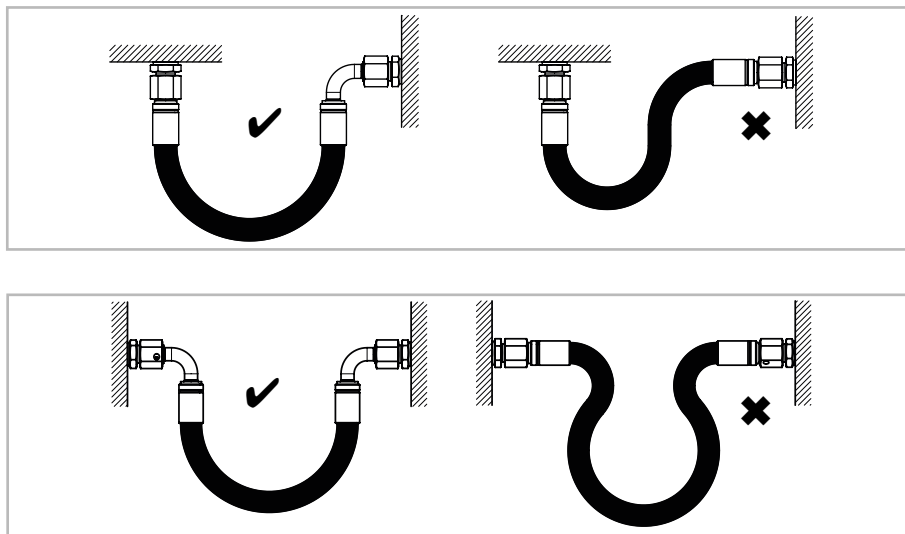

5. Sonstige Hinweise

Überwurfmuttern nur soweit anziehen, bis der Anschluss dicht ist. Weiteres Anziehen verbessert die Dichtheit nicht, sondern beschädigt den Anschluss.

Informieren Sie sich über Schutzschläuche. Sie bieten Hydraulikschläuchen zusätzlichen Schutz gegen Beschädigung (Feuer, mechanische Einwirkungen) oder kennzeichnen die Medien.

5. Additional information

Nuts should only be tightened up to the point of leak-tightness. Further tightening will not improve the leak-tightness of the connection, but will damage it.

Inform yourself about protective hoses. They offer the hydraulic hoses additional protection against damage (fire, mechanical effects) or mark the media.

5. Otras indicaciones

Apriete las tuercas de racor solo hasta que la conexión sea hermética. Apretarlas más no mejoraría la hermeticidad; antes bien, el hacerlo dañaría la conexión.

Infórmese sobre los tubos flexibles de aislamiento. Estos dotan a las mangueras hidráulicas de una protección adicional contra daños (fuego, acciones mecánicas) o identifican los fluidos utilizados.

Technische Information
Rohre und Schläuche

Technical information
Tubes and hoses

Información técnica
Tubos y mangueras

Eigenschaften, Besonderheiten

- speziell auf EXMAR-Verbindungen abgestimmt
- reichhaltiges Zubehör
- Rohre und Schläuche für spezielle Anwendungen
- verschiedene Materialien

Kunststoffrohre

Speziell für Niederdruck- und Niedertemperaturbereich geeignet.

Ablängen

Kombizangen, Scheren usw. können Rohrenden quetschen, was später oft zu Rissbildungen führt. Mit dem "Schlauch-Cutty" lassen sich Kunststoffrohre einwandfrei zuschneiden.

Wärmedehnung

Bei Montage zu beachten:
Große Wärmeausdehnung bzw. Kontraktion bei Kälte führen zu Längenänderungen.

Licht- und Temperaturbeständigkeit

Kunststoffrohre sollten nicht direkter Sonnenbestrahlung ausgesetzt werden und nicht in Berührung mit heißen Teilen kommen bzw. nicht im Bereich von Wärmestauungen installiert werden. Ggf. schwarze Rohre verwenden. Sie sind lichtbeständig und gegen Wärmealterung unempfindlich.

Characteristics, specialities

- fits the special requirements of the EXMAR unions
- wide range of accessories
- tubes and hoses for special applications
- different materials available

Plastic tubing

Especially suitable for low pressure and low temperature ranges.

Cutting to length

Combination shears, scissors etc. can crush the tube ends and are often the cause for later splitting. The "Hose Cutty" is the ideal tool for the clean cutting.

Thermal expansion

Plastic tubing has a high thermal expansion or contraction. Proper installation entails the consideration of the temperature-dependent dimensional changes.

Light and temperature stabilized

Plastics should not be exposed to direct sunlight, should not come into contact with hot components nor installed in hot areas. Black plastic tubing should be used preferably (light and temperature stabilized).

Propiedades, particularidades

- adaptado especialmente a las uniones EXMAR
- numerosos accesorios
- tubos y mangueras para aplicaciones especiales
- diferentes materiales

Tubos de plástico

Especialmente adecuados para aplicaciones de baja presión y baja temperatura.

Corte a medida

Los alicates universales, las cizallas, etc. pueden aplastar los extremos de los tubos y favorecer la aparición de grietas más adelante. El cortador de mangueras "Cutty" permite cortar a medida tubos de plástico.

Dilatación térmica

Para tener en cuenta en el montaje:
Valores altos de dilatación térmica o contracción por frío provocan variaciones de longitud.

Resistencia a la luz y la temperatura

Los tubos de plástico no deben estar expuestos a radiación solar directa, entrar en contacto con piezas muy calientes o instalarse cerca de zonas en las que se acumule el calor. En su caso, utilizar tubos negros: son resistentes a la luz y al envejecimiento por calor.

Präzisionsrohre aus Edelstahl 1.4571
Stainless steel tubes 1.4571
Tubos de precisión de acero inoxidable 1.4571

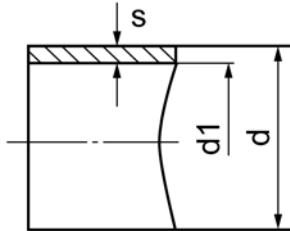

INOX 1.4571

Type d / d1 x s	Mat.-Nr.	PN	d	d1	s	kg/m
Inox-Rohr 6/4x1 (1.4571) 6m	450.1006.200	530	6.00	4.00	1.00	0.130
Inox-Rohr 8/6x1 (1.4571) 6m	450.1006.300	380	8.00	6.00	1.00	0.180
Inox-Rohr 10/7x1,5 (1.4571) 6m	450.1006.355	490	10.00	7.00	1.50	0.319
Inox-Rohr 10/8x1 (1.4571) 6m	450.1006.350	290	10.00	8.00	1.00	0.260
Inox-Rohr 12/9x1,5 (1.4571) 6m	450.1006.405	370	12.00	9.00	1.50	0.390
Inox-Rohr 15/12x1,5 (1.4571) 6m	450.1006.555	270	15.00	12.00	1.50	0.500
Inox-Rohr 18/15x1,5 (1.4571) 6m	450.1006.705	240	18.00	15.00	1.50	0.620

Druckauswertungsgrad in % des PN				Pressure coefficient in % of PN			Coeficiente de presión en % de la PN			
°C										
-196°	-110°	-60°	0°		300°	400°	450°	500°	600°	
50 %	70 %			100 %	75 %	60 %	50 %	auf Anfrage on request bajo demanda		

Spezifikationen:	Specifications:	Especificaciones:
Werkstoff: 1.4571 (≈ AISI 316Ti)	Material: 1.4571 (≈ AISI 316Ti)	Material: 1.4571 (≈ AISI 316Ti)
Temperaturbereich: -196°C bis +500°C (bis +600°C auf Anfrage)	Temperature range: -196° to +500°C (up to +600°C on request)	Intervalo de temperatura: -196°C a +500°C (hasta +600°C bajo demanda)
Berstdruck: 4-facher Betriebsdruck bei ruhender Belastung	Burst pressure: 4 times working pressure under static load	Presión de rotura: 4 veces la presión de servicio con carga estática
Abmessungen und Toleranzen: siehe Kapitel i	Dimensions and tolerances: see chapter i	Dimensiones y tolerancias: ver capítulo i

Merkmale:	Characteristics:	Características:
- nahtlos gezogene Präzisionsrohre nach EN 10305-1 / EN 10216-5 / EN ISO 1127	- seamless, cold drawn, high precision tubes according to EN 10305-1 / EN 10216-5 / EN ISO 1127	- tubos de precisión estirados sin costuras según EN 10305-1 / EN 10216-5 / EN ISO 1127
- speziell auf unsere Verschraubungen abgestimmt	- especially adapted to our unions	- adaptados especialmente a nuestros racores
- Bescheinigungen über Werkstoffprüfungen nach DIN EN 10204 können abgegeben werden	- material test certificates according to DIN EN 10204 can be provided upon request	- posibilidad de entregar certificados de ensayos de material según DIN EN 10204

PN=Arbeitsdruck bei +23°C
d=Rohr außen-ø
d1=Rohr innen-ø
s=Wandstärke

PN=operation pressure at +23°C
d=tube outside diameter
d1=tube inside diameter
s=wall thickness

PN=presión de trabajo a +23°C
d=ø exterior tubo
d1=ø interior tubo
s=grosor de pared

Präzisionsrohre aus Edelstahl 1.4301
Stainless steel tubes 1.4301
Tubos de precisión de acero inoxidable 1.4301

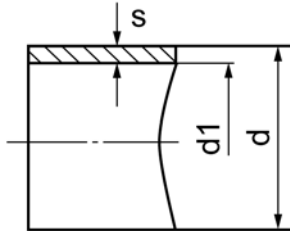

INOX 1.4301

Type d / d1 x s	Mat.-Nr.	PN	d	d1	s	kg/m
Inox-Rohr 6/4x1 (1.4301) 6m	451.1006.200	530	6.00	4.00	1.00	0.130
Inox-Rohr 8/6x1 (1.4301) 6m	451.1006.300	380	8.00	6.00	1.00	0.180
Inox-Rohr 10/8x1 (1.4301) 6m	451.1006.350	290	10.00	8.00	1.00	0.260

Druckauswertungsgrad in % des PN				Pressure coefficient in % of PN			Coeficiente de presión en % de la PN			
°C										
-196°	-110°	-60°	0°		300°	400°	450°	500°	600°	
50%	70%			100%	75%	60%	50%	auf Anfrage on request bajo demanda		

Spezifikationen:	Specifications:	Especificaciones:
Werkstoff: 1.4301 (= AISI 304) Temperaturbereich: -196°C bis +500°C (bis +600°C auf Anfrage) Berstdruck: 4-facher Betriebsdruck bei ruhender Belastung Abmessungen und Toleranzen: siehe Kapitel i	Material: 1.4301 (= AISI 304) Temperature range: -196°C to +500°C (up to +600°C on request) Burst pressure: 4 times working pressure under static load Dimensions and tolerances: see chapter i	Material: 1.4301 (= AISI 304) Intervalo de temperatura: -196°C a +500°C (hasta +600°C bajo demanda) Presión de rotura: 4 veces la presión de servicio con carga estática Dimensiones y tolerancias: ver capítulo i

Merkmale:	Characteristics:	Características:
- nahtlos gezogene Präzisionsrohre nach EN 10305-1 / EN 10216-5 / EN ISO 1127 - speziell auf unsere Verschraubungen abgestimmt - Bescheinigungen über Werkstoffprüfungen nach DIN EN 10204 können abgegeben werden	- seamless, cold drawn, high precision tubes according to EN 10305-1 / EN 10216-5 / EN ISO 1127 - especially adapted to our unions - material test certificates according to DIN EN 10204 can be provided upon request	- tubos de precisión estirados sin costuras según EN 10305-1 / EN 10216-5 / EN ISO 1127 - adaptados especialmente a nuestros racores - posibilidad de entregar certificados de ensayos de material según DIN EN 10204

PN=Arbeitsdruck bei +23°C
d=Rohr außen-ø
d1=Rohr innen-ø
s=Wandstärke

PN=operation pressure at +23°C
d=tube outside diameter
d1=tube inside diameter
s=wall thickness

PN=presión de trabajo a +23°C
d=ø exterior tubo
d1=ø interior tubo
s=grosor de pared

Polyamid-Rohr (PA)
Polyamide tube (PA)
Tubo de poliamida (PA)

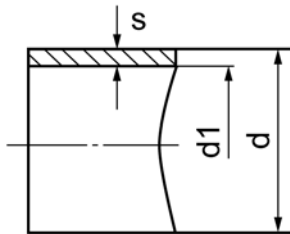

PA-ROHRE

Type d / d1 x s (1)	Mat.-Nr.	PN	d	d1	s	Tol. d	B.Radius	kg/100m
PAW 4/2x1 W, 100m	421.1100.105	44	4.00	2.00	1.00	±0.10	15	0.970
PAW 5/3x1 W, 100m	421.1150.105	33	5.00	3.00	1.00	±0.10	30	1.140
PAW 6/4x1 W, 100m	421.1200.105	27	6.00	4.00	1.00	±0.10	35	1.620
PAW 6/4x1 S, 100m	421.1200.205	27	6.00	4.00	1.00	±0.10	35	1.620
PAW 6/4x1 S, 500m	421.1200.208	27	6.00	4.00	1.00	±0.10	35	1.620
PAW 6/4x1 B, 100m	421.1200.305	27	6.00	4.00	1.00	±0.10	35	1.620
PAW 6/4x1 R, 100m	421.1200.405	27	6.00	4.00	1.00	±0.10	35	1.620
PAW 6/4x1 Y, 100m	421.1200.505	27	6.00	4.00	1.00	±0.10	35	1.620
PAW 6/4x1 G, 100m	421.1200.605	27	6.00	4.00	1.00	±0.10	35	1.620
PAW 8/6x1 W, 100m	421.1300.105	19	8.00	6.00	1.00	±0.10	40	2.270
PAW 8/6x1 S, 100m	421.1300.205	19	8.00	6.00	1.00	±0.10	40	2.270
PAW 8/6x1 B, 100m	421.1300.305	19	8.00	6.00	1.00	±0.10	40	2.270
PAW 8/6x1 R, 100m	421.1300.405	19	8.00	6.00	1.00	±0.10	40	2.270
PAW 8/6x1 G, 100m	421.1300.605	19	8.00	6.00	1.00	±0.10	40	2.270
PAW 10/8x1 W, 50m	421.1350.105	15	10.00	8.00	1.00	±0.10	60	2.910
PAW 10/8x1 S, 50m	421.1350.205	15	10.00	8.00	1.00	±0.10	60	2.910
PAW 10/8x1 B, 50m	421.1350.305	15	10.00	8.00	1.00	±0.10	60	2.910
PAW 10/7x1,5 W, 50m	421.1355.105	24	10.00	7.00	1.50	±0.10	45	3.540
PAW 12/10x1 W, 50m	421.1400.105	12	12.00	10.00	1.00	±0.15	85	4.000
PAW 12/10x1 S, 50m	421.1400.205	12	12.00	10.00	1.00	±0.15	85	4.000
PAW 12/9x1.5 W, 50m	421.1405.105	19	12.00	9.00	1.50	±0.15	70	5.100
PAW 12/9x1.5 S, 50m	421.1405.205	19	12.00	9.00	1.50	±0.15	70	5.100
PAW 15/12x1.5 W, 50m	421.1555.103	15	15.00	12.00	1.50	±0.15	100	6.570

70

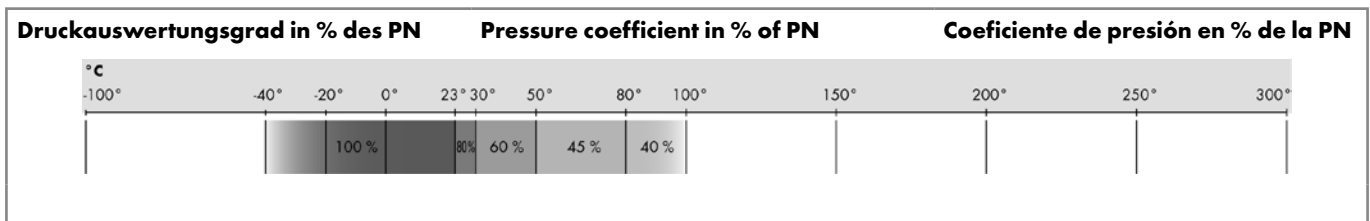

PN=Arbeitsdruck bei +23°C
 B.Radius=min. Biegeradius
 d=Rohr außen-ø
 d1=Rohr innen-ø
 s=Wandstärke

PN=operation pressure at +23°C
 B.Radius=min. bending radius
 d=tube outside diameter
 d1=tube inside diameter
 s=wall thickness

PN=presión de trabajo a +23°C
 B.Radius=radio de curvatura min.
 d=ø exterior tubo
 d1=ø interior tubo
 s=grosor de pared

Rohre, Schläuche

Tubes, Hoses

Tubos, Mangueras

Spezifikationen:

Werkstoff: Polyamid PA 12/PA10.12 weich
 Temperaturbereich: -40°C bis +100°C (kurzfristig: +125°C)
 Brandverhalten: gem. UL 94 HB
 Härte: Shore D65
 Berstdruck: 3-facher Betriebsdruck
 (1) Farben: W = weiß, S = schwarz, B = blau, R = rot, Y = gelb, G = grün
 Alle technischen Daten basieren auf den Herstellerangaben.

Specifications:

Material: Polyamide PA 12/PA10.12 soft
 Temperature range: -40°C to +100°C (short-term: +125°C)
 Flammability: acc. to UL 94 HB
 Hardness: Shore D65
 Burst pressure: 3 x working pressure
 (1) Colors: W = white, S = black, B = blue, R = red, Y = yellow, G = green
 All technical data are based on manufacturer's specifications.

Especificaciones:

Material: poliamida PA 12/PA10.12 blando
 Intervalo de temperatura: -40°C a +100°C (brevemente: +125°C)
 Inflamabilidad: según UL 94 HB
 Dureza: Shore D65
 Presión de rotura: 3 x presión de servicio
 (1) Colores: W = blanco, S = negro, B = azul, R = rojo, Y = amarillo, G = verde
 Todos los datos técnicos se basan en las indicaciones del fabricante.

Merkmale:

- breiter Temperatur- und Einsatzbereich
- Farbe schwarz, UV-beständig
- silikonfrei, halogenfrei
- druckbeständig, schlag- und kerbschlagzäh
- glatte und undurchlässige Oberfläche
- Beständigkeitsliste siehe Anhang
- Anwendungen: Druckluft, Hydraulik, Unterdruck, Kühlleitungen, Kraftstoff- und Schmierleitungen

Characteristics:

- wide temperature and application range
- colour black, UV resistant
- silicone free, halogen free
- pressure and impact resistant
- smooth surface and impermeable
- chemical resistance list see appendix.
- applications: compressed air, hydraulics, negative pressure, cooling lines, fuel and lubricating lines

Características:

- intervalo de temperatura y campo de aplicación amplio
- color negro, resistente a los rayos UV
- sin silicona, sin halógenos
- resistente a la presión y alos impacto
- superficie lisa e impermeable
- lista de resistencias, ver anexo
- aplicaciones: aire a presión, hidráulica, presión negativa, tuberías de refrigeración, tuberías de combustible y lubricante

PN=Arbeitsdruck bei +23°C
 B.Radius=min. Biegeradius
 d=Rohr außen-ø
 d1=Rohrinnen-ø
 s=Wandstärke

PN=operation pressure at +23°C
 B.Radius=min. bending radius
 d=tube outside diameter
 d1=tube inside diameter
 s=wall thickness

PN=presión de trabajo a +23°C
 B.Radius=radio de curvatura min.
 d=ø exterior tubo
 d1=ø interior tubo
 s=grosor de pared

Polyethylen-Rohr (LD-PE)
Polyethylene tube (LD-PE)
Tubo de polietileno (LD-PE)

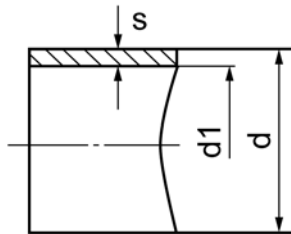

LDPE-ROHRE

Type d / d1 x s (1)	Mat.-Nr.	PN	d	d1	s	Tol. d	B.Radius	kg/100m
LDPE 4/2x1 W, 100m	420.0100.105	21	4.00	2.00	1.00	±0.20	18	1.180
LDPE 4/2x1 S, 100m	420.0100.205	21	4.00	2.00	1.00	±0.20	18	1.180
LDPE 5/3x1 W, 100m	420.0150.105	14	5.00	3.00	1.00	±0.20	20	1.470
LDPE 5/3x1 S, 100m	420.0150.205	14	5.00	3.00	1.00	±0.20	20	1.470
LDPE 6/4x1 W, 100m	420.0200.105	13	6.00	4.00	1.00	±0.20	30	1.540
LDPE 6/4x1 W, 250m	420.0200.115	13	6.00	4.00	1.00	±0.20	30	1.540
LDPE 6/4x1 S, 100m	420.0200.205	13	6.00	4.00	1.00	±0.20	30	1.540
LDPE 6/4x1 S, 250m	420.0200.215	13	6.00	4.00	1.00	±0.20	30	1.540
LDPE 6/4x1 B, 100m	420.0200.305	13	6.00	4.00	1.00	±0.20	30	1.540
LDPE 6/4x1 B, 250m	420.0200.315	13	6.00	4.00	1.00	±0.20	30	1.540
LDPE 6/4x1 R, 100m	420.0200.405	13	6.00	4.00	1.00	±0.20	30	1.540
LDPE 6/4x1 R, 250m	420.0200.415	13	6.00	4.00	1.00	±0.20	30	1.540
LDPE 6/4x1 Y, 100m	420.0200.505	13	6.00	4.00	1.00	±0.20	30	1.540
LDPE 6/4x1 G, 100m	420.0200.605	13	6.00	4.00	1.00	±0.20	30	1.540
LDPE 6,35/4,35x1 W, 100m	420.0210.105	10	4.00	4.35	1.00	±0.20	30	2.050
LDPE 8/6x1 W, 100m	420.0300.105	9	8.00	6.00	1.00	±0.20	40	2.640
LDPE 8/6x1 S, 100m	420.0300.205	9	8.00	6.00	1.00	±0.20	40	2.640
LDPE 8/6x1 B, 100m	420.0300.305	9	8.00	6.00	1.00	±0.20	40	2.640
LDPE 8/6x1 R, 100m	420.0300.405	9	8.00	6.00	1.00	±0.20	40	2.640
LDPE 8/6x1 Y, 100m	420.0300.505	9	8.00	6.00	1.00	±0.20	40	2.640
LDPE 8/6x1 G, 100m	420.0300.605	9	8.00	6.00	1.00	±0.20	40	2.640
LDPE 9.52/6.52x1.5 W, 100m	420.0315.105	10	9.52	6.52	1.50	±0.20	40	3.000
LDPE 10/8x1 W, 50m	420.0350.105	7	10.00	8.00	1.00	±0.20	60	3.230
LDPE 10/8x1 S, 50m	420.0350.205	7	10.00	8.00	1.00	±0.20	60	3.230
LDPE 10/8x1 B, 50m	420.0350.305	7	10.00	8.00	1.00	±0.20	60	3.230
LDPE 10/8x1 R, 50m	420.0350.405	7	10.00	8.00	1.00	±0.20	60	3.230
LDPE 10/7x1.5 W, 50m	420.0355.105	11	10.00	7.00	1.50	±0.20	40	3.740
LDPE 10/7x1.5 S, 50m	420.0355.205	11	10.00	7.00	1.50	±0.20	40	3.740
LDPE 12/10x1 W, 50m	420.0400.105	6	12.00	10.00	1.00	±0.30	80	4.620
LDPE 12/10x1 S, 50m	420.0400.205	6	12.00	10.00	1.00	±0.30	80	4.620
LDPE 12/9x1.5 W, 50m	420.0405.105	9	12.00	9.00	1.50	±0.30	65	4.620
LDPE 12/9x1.5 S, 50m	420.0405.205	9	12.00	9.00	1.50	±0.30	65	4.620
LDPE 16/13x1.5 W, 50m	420.0500.105	6	16.00	13.00	1.50	±0.20	80	7.000

PN=Arbeitsdruck bei +23°C
 B.Radius=min. Biegeradius
 d=Rohr außen-ø
 d1=Rohrinnen-ø
 s=Wandstärke

PN=operation pressure at +23°C
 B.Radius=min. bending radius
 d=tube outside diameter
 d1=tube inside diameter
 s=wall thickness

PN=presión de trabajo a +23°C
 B.Radius=radio de curvatura min.
 d=ø exterior tubo
 d1=ø interior tubo
 s=grosor de pared

70

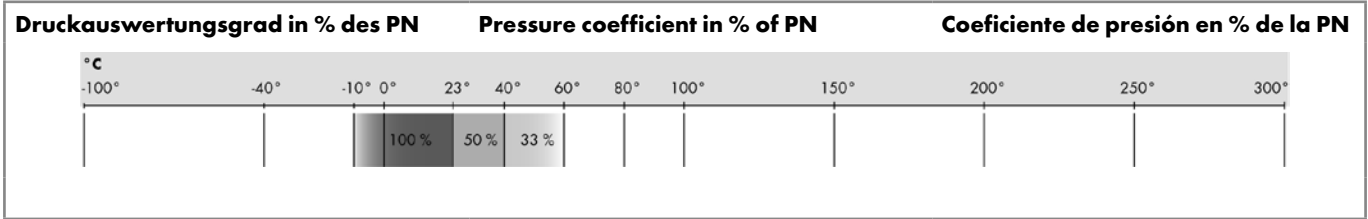

<p>Spezifikationen: Werkstoff: Polyethylen LD (niedrige Dichte) Temperaturbereich: -10°C bis +60°C (kurzfristig: +80°C) Brandverhalten: gem. UL 94 HB Härte: Shore D45 Berstdruck: 3-facher Betriebsdruck (1) Farben: W = weiß, S = schwarz, B = blau, R = rot, Y = gelb, G = grün Alle technischen Daten basieren auf den Herstellerangaben.</p>	<p>Specifications: Material: Polyethylene LD (low density) Temperature range: -10°C to +60°C (short-term: +80°C) Flammability: acc. to UL 94 HB Hardness: Shore D45 Burst pressure: 3 x working pressure (1) Colours: W = white, S = black, B = blue, R = red, Y = yellow, G = green All technical data are based on manufacturer's specifications.</p>	<p>Especificaciones: Material: polietileno LD (baja densidad) Intervalo de temperatura: -10°C a +60°C (brevemente: +80°C) Inflamabilidad: según UL 94 HB Dureza: Shore D45 Presión de rotura: 3 x presión de servicio (1) Colores: W = blanco, S = negro, B = azul, R = rojo, Y = amarillo, G = verde Todos los datos técnicos se basan en las indicaciones del fabricante.</p>
---	---	---

<p>Merkmale: - gute Flexibilität, schlagfest - Farbe schwarz UV-beständig - silikonfrei, halogenfrei - physiologisch unbedenklich - Beständigkeitsliste siehe Anhang - Anwendungen: Druckluftleitungen für Regeltechnik, Probenahmeleitungen, flexible Pneumatikleitungen im unteren Druckbereich, Umgebungen mit hohem Feuchtigkeitsgrad</p>	<p>Characteristics: - good flexibility, impact resistant - colour black UV-resistant - silicone free, halogen free - non-toxic - chemical resistance list see appendix - applications: compressed air for control technology, sampling lines, flexible pneumatic lines in low pressure range, environments with high humidity</p>	<p>Características: - buena flexibilidad, a prueba de golpes - color negro resistente a los rayos UV - sin silicona, sin halógenos - fisiológicamente inocuo - lista de resistencias, ver anexo - aplicaciones: tuberías de aire a presión para técnica de regulación, tuberías de muestreo, tuberías neumáticas flexibles para bajas presiones, entornos con alto índice de humedad.</p>
--	--	--

PN=Arbeitsdruck bei +23°C
 B.Radius=min. Biegeradius
 d=Rohr außen-ø
 d1=Rohr innen-ø
 s=Wandstärke

PN=operation pressure at +23°C
 B.Radius=min. bending radius
 d=tube outside diameter
 d1=tube inside diameter
 s=wall thickness

PN=presión de trabajo a +23°C
 B.Radius=radio de curvatura min.
 d=ø exterior tubo
 d1=ø interior tubo
 s=grosor de pared

Polyurethan-Rohr (PU)
Polyurethane tube (PU)
Tubo de poliuretano (PU)

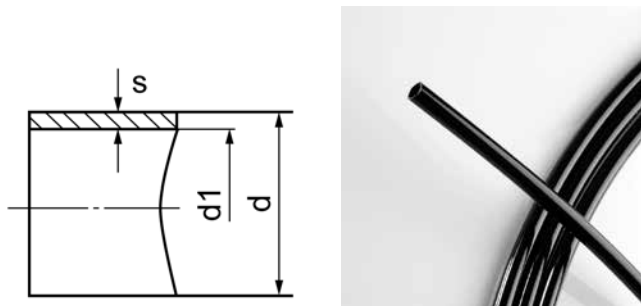

PU-ROHRE

Type d / d1 x s (1)	Mat.-Nr.	PN	d	d1	s	Tol. d	B.Radius	kg/100m
PU 6/4x1 S, 100m	424.0200.205	13	6.00	4.00	1.00	±0.10	20	2.000
PU 6/4x1 B, 100m	424.0200.305	13	6.00	4.00	1.00	±0.10	20	2.000
PU 8/6x1 S, 100m	424.0300.205	10	8.00	6.00	1.00	±0.10	25	3.400
PU 8/6x1 B, 100m	424.0300.305	10	8.00	6.00	1.00	±0.10	25	3.400
PU 10/8x1 S, 100m	424.0350.205	7	10.00	8.00	1.00	±0.15	35	5.200
PU 10/8x1 B, 100m	424.0350.305	7	10.00	8.00	1.00	±0.15	35	5.200

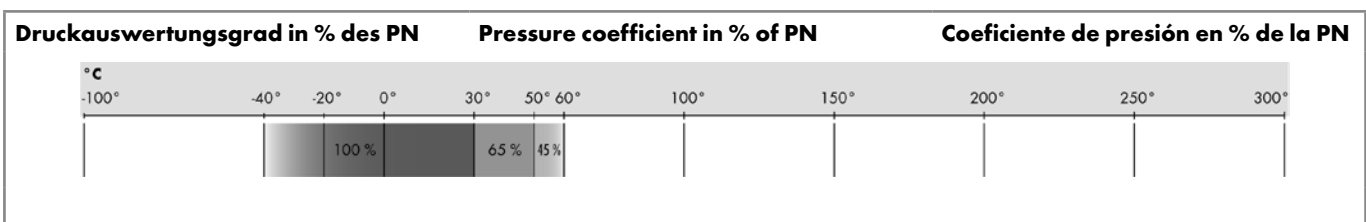

Spezifikationen:	Specifications:	Especificaciones:
Werkstoff: Polyurethan	Material: Polyurethane	Material: poliuretano
Temperaturbereich: -40°C bis +60°C (kurzfristig: +80°C)	Temperature range: -40°C to +60°C (short-term: +80°C)	Intervalo de temperatura: -40°C a +60°C (brevemente: +80°C)
Brandverhalten: gem. UL 94 HB	Flammability: acc. to UL 94 HB	Inflamabilidad: según UL 94 HB
Härte: Shore D52	Hardness: Shore D52	Dureza: Shore D52
Berstdruck: 3-facher Betriebsdruck	Burst pressure: 3 x working pressure	Presión de rotura: 3 x presión de servicio
(1) Farben: S = schwarz, B = blau	(1) Colors: S = black, B = blue	(1) Colores: S = negro, B = azul
Alle technischen Daten basieren auf den Herstellerangaben.	All technical data are based on manufacturer's specifications.	Todos los datos técnicos se basan en las indicaciones del fabricante.

Merkmale:	Characteristics:	Características:
- hervorragende Biegefähigkeit, hohe Kälteflexibilität	- excellent bending, high cold flexibility	- flexibilidad extraordinaria, alta flexibilidad en frío
- geringe Verformung auch bei Langzeitbelastung	- little deformation even with long-term stress	- baja deformación incluso con cargas prolongadas
- silikonfrei, halogenfrei	- silicone free, halogen free	- sin silicona, sin halógenos
- abriebfest	- abrasion resistant	- resistente al desgaste
- Beständigkeitsliste siehe Anhang	- chemical resistance list see appendix	- lista de resistencias, ver anexo
- Anwendungen: Mess- und Regeltechnik, Pneumatik, Hydraulik, Maschinen- und Motorenbau, Kraftstoff- und Schmierleitungen	- applications: measurement and control technology, pneumatics, hydraulics, machine and motor engineering, fuel and lubricating lines	- aplicaciones: técnica de medición y regulación, neumática, hidráulica, construcción de máquinas y motores, tuberías de combustible y lubricante

PN=Arbeitsdruck bei +23°C
 B.Radius=min. Biegeradius
 d=Rohr außen-ø
 d1=Rohr innen-ø
 s=Wandstärke

PN=operation pressure at +23°C
 B.Radius=min. bending radius
 d=tube outside diameter
 d1=tube inside diameter
 s=wall thickness

PN=presión de trabajo a +23°C
 B.Radius=radio de curvatura min.
 d=ø exterior tubo
 d1=ø interior tubo
 s=grosor de pared

Polytetrafluorethylen-Rohr (PTFE)
Polytetrafluorethylene tube (PTFE)
Tubo de politetrafluoroetileno (PTFE)

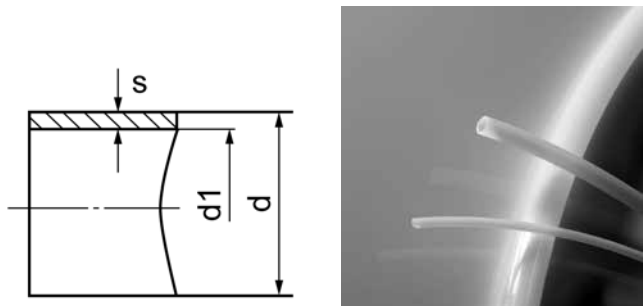

PTFE-ROHRE

Type d / d1 x s	Mat.-Nr.	PN	d	d1	s	Tol. d	B.Radius	kg/100m
PTFE 2/1x0,5, 50m	431.0040.000	46	2.00	1.00	0.50	±0.10	8	1.200
PTFE 3/2x0,5, 50m	431.0050.000	23	3.00	2.00	0.50	±0.10	12	1.520
PTFE 4/2x1, 50m	431.0100.000	46	4.00	2.00	1.00	±0.10	12	2.100
PTFE 5/3x1, 50m	431.0150.000	31	5.00	3.00	1.00	±0.15	15	2.900
PTFE 6/4x1, 50m	431.0200.000	23	6.00	4.00	1.00	±0.15	20	3.700
PTFE 6/4x1, 100m	431.0200.010	23	6.00	4.00	1.00	±0.15	20	3.700
PTFE 8/6x1, 50m	431.0300.000	15	8.00	6.00	1.00	±0.15	40	5.120
PTFE 8/6x1, 100m	431.0300.010	15	8.00	6.00	1.00	±0.15	40	5.120
PTFE 10/8x1, 50m	431.0350.000	11	10.00	8.00	1.00	±0.20	55	5.760
PTFE 10/7x1,5, 50m	431.0355.000	20	10.00	7.00	1.50	±0.20	50	8.800
PTFE 12/10x1, 50m	431.0400.000	9	12.00	10.00	1.00	±0.20	90	7.360
PTFE 12/9x1,5, 50m	431.0405.000	15	12.00	9.00	1.50	±0.20	60	11.040
PTFE 16/13x1,5, 50m	431.0605.000	10	16.00	13.00	1.50	±0.25	100	14.700

Druckauswertungsgrad in % des PN

Pressure coefficient in % of PN

Coeficiente de presión en % de la PN

°C											
-100°	-75°	-40°	0°	23°	50°	75°	100°	150°	200°	250°	300°
25 %	50 %	100 %		77 %	59 %	48 %	33 %	25 %			

Spezifikationen:

Werkstoff: Polytetrafluorethylen, FDA-konform
 Temperaturbereich: -200°C bis +200°C
 (kurzfristig: +260°C)
 Brandverhalten: gem. UL 94 V0
 Härte: Shore D55
 Berstdruck: 3-facher Betriebsdruck
 Farbe: natur
 Alle technischen Daten basieren auf den Herstellerangaben.

Specifications:

Material: Polytetrafluoroethylene, FDA approved
 Temperature range: -200°C to +200°C (short-term: +260°C)
 Flammability: acc. to UL 94 V0
 Hardness: Shore D55
 Burst pressure: 3 x working pressure
 Colour: natural
 All technical data are based on manufacturer's specifications.

Especificaciones:

Material: politetrafluoroetileno, cumple la FDA
 Intervalo de temperatura: -200°C a +200°C (brevemente: +260°C)
 Inflamabilidad: según UL 94 V0
 Dureza: Shore D55
 Presión de rotura: 3 x presión de servicio
 Color: natural
 Todos los datos técnicos se basan en las indicaciones del fabricante.

PN=Arbeitsdruck bei +23°C
 B.Radius=min. Biegeradius
 d=Rohr außen-ø
 d1=Rohr innen-ø
 s=Wandstärke

PN=operation pressure at +23°C
 B.Radius=min. bending radius
 d=tube outside diameter
 d1=tube inside diameter
 s=wall thickness

PN=presión de trabajo a +23°C
 B.Radius=radio de curvatura min.
 d=ø exterior tubo
 d1=ø interior tubo
 s=grosor de pared

Rohre, Schläuche

Tubes, Hoses

Tubos, Mangueras

Merkmale:

- gute Temperaturbeständigkeit
- physiologisch unbedenklich
- nicht leitfähig
- hohe Festigkeit, Steifheit, Zähigkeit, sehr flexibel
- UV- und witterungsbeständig
- ausgezeichnete Antihafteigenschaften
- nicht geeignet für Druckpulsation
Empfehlung: FEP, PFA oder Jacoflon verwenden
- universelle chemische Beständigkeit;
Beständigkeitsliste siehe Anhang
- Anwendungen: Labor, Medizin, Chemie,
Analysentechnik, Vakuum

Characteristics:

- good temperature resistance
- non-toxic
- non-conductive
- high strength, rigidity, toughness and very good flexibility
- UV and weather resistant
- outstanding non-stick properties
- not suitable for pressure pulsation
recommendation: use FEP, PFA or Jacoflon
- universal chemical resistance; chemical resistance list see appendix
- applications: laboratory, medicine, chemical engineering, analysis technology, vacuum

Características:

- buena resistencia a la temperatura
- fisiológicamente inocuo
- no conductivo
- alta resistencia mecánica, rigidez, tenacidad, muy buena flexibilidad
- resistente a los rayos UV y a la intemperie
- propiedades antiadherentes extraordinarias
- no apto para pulsación de presión recomendación: utilizar FEP, PFA o Jacoflon
- resistencia química universal; lista de resistencias: ver anexo
- aplicaciones: laboratorios, medicina, sector químico, técnica de análisis, vacío

PN=Arbeitsdruck bei +23 °C
 B.Radius=min. Biegeradius
 d=Rohraußen-ø
 d1=Rohrinnen-ø
 s=Wandstärke

PN=operation pressure at +23 °C
 B.Radius=min. bending radius
 d=tube outside diameter
 d1=tube inside diameter
 s=wall thickness

PN=presión de trabajo a +23 °C
 B.Radius=radio de curvatura min.
 d=ø exterior tubo
 d1=ø interior tubo
 s=grosor de pared

Polyvinylidenfluorid-Rohr (PVDF)

Polyvinylide fluoride tube (PVDF)

Tubo de polivinilidenfluoruro (PVDF)

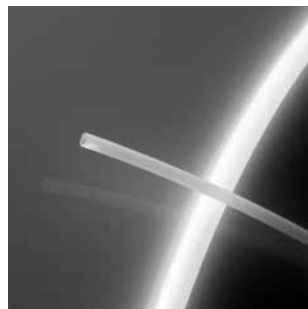
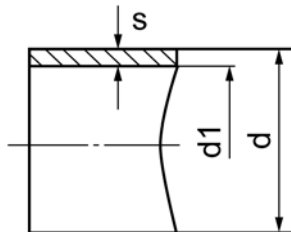

PVDF-ROHRE

Type d / d1 x s	Mat.-Nr.	PN	d	d1	s	Tol. d	B.Radius	kg/100m
PVDF 6/4x1, 50m	430.0200.003	36	6.00	4.00	1.00	±0.10	70	2.800
PVDF 8/6x1, 50m	430.0300.003	24	8.00	6.00	1.00	±0.12	130	3.850
PVDF 10/8x1, 50m	430.0350.003	18	10.00	8.00	1.00	±0.15	200	5.000
PVDF 12/10x1, 50m	430.0400.003	15	12.00	10.00	1.00	±0.20	293	6.000
PVDF 12/9x1.5, 50m	430.0405.003	24	12.00	9.00	1.50	±0.20	200	8.200
PVDF 16/13x1.5, 50m	430.0605.003	16	16.00	13.00	1.50	±0.25	375	9.500

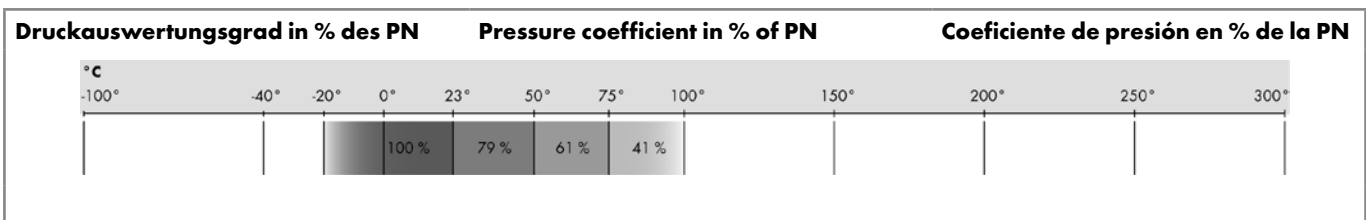

Spezifikationen:	Specifications:	Especificaciones:
Werkstoff: Polyvinylidenfluorid, FDA-konform	Material: Polyvinylide fluoride, FDA approved	Material: polivinilidenfluoruro, cumple la FDA
Temperaturbereich: -20°C bis +100°C (kurzfristig: +130°C)	Temperature range: -20°C to +100°C (short-term: +130°C)	Intervalo de temperatura: -20°C a +100°C (brevemente: +130°C)
Brandverhalten: gem. UL 94 V0	Flammability: acc. to UL 94 V0	Inflamabilidad: según UL 94 V0
Härte: Shore D78	Hardness: Shore D78	Dureza: Shore D78
Berstdruck: 3-facher Betriebsdruck	Burst pressure: 3 x working pressure	Presión de rotura: 3 x presión de servicio
Farbe: natur	Colour: natural	Color: natural
Alle technischen Daten basieren auf den Herstellerangaben.	All technical data are based on manufacturer's specifications.	Todos los datos técnicos se basan en las indicaciones del fabricante.

Merkmale:	Characteristics:	Características:
- molekularer, teilkristalliner Thermoplast	- molecular, partially crystalline thermoplastic	- termoplástico molecular semicristalino
- hervorragende Kombination von Festigkeit, Zähigkeit, Abriebfestigkeit	- excellent combination of stability, strength, abrasion resistance	- combinación excelente entre resistencia mecánica, fortaleza y resistencia al desgaste
- enorme Spannungsris- und Chemikalienbeständigkeit	- excellent stress crack and chemical resistance	- extraordinaria resistencia a la corrosión interna por fisuras y a los productos químicos
- physiologisch unbedenklich, sterilisierbar	- non-toxic, sterilisable	- fisiológicamente inocuo, esterilizable
- silikonfrei	- silicone free	- sin silicona
- UV- und witterungsbeständig	- UV and weather resistant	- resistente a los rayos UV y a la intemperie
- verschweisbar	- weldable	- soldable
- Beständigkeitsliste siehe Anhang	- chemical resistance list see appendix	- lista de resistencias, ver anexo
- Anwendungen: Medizin, Chemie, Analysetechnik, Nahrungsmittelindustrie	- applications: medicine, chemical engineering, analysis technology, food industry	- aplicaciones: medicina, sector químico, técnica de análisis, industria alimentaria

PN=Arbeitsdruck bei +23°C
 B.Radius=min. Biegeradius
 d=Rohraußen-ø
 d1=Rohrinnen-ø
 s=Wandstärke

PN=operation pressure at +23°C
 B.Radius=min. bending radius
 d=tube outside diameter
 d1=tube inside diameter
 s=wall thickness

PN=presión de trabajo a +23°C
 B.Radius=radio de curvatura min.
 d=ø exterior tubo
 d1=ø interior tubo
 s=grosor de pared

Perfluorethylenpropylen-Rohr (FEP)
Fluorinated ethylene propylene tube (FEP)
Tubo de perfluoretileno/propileno (FEP)

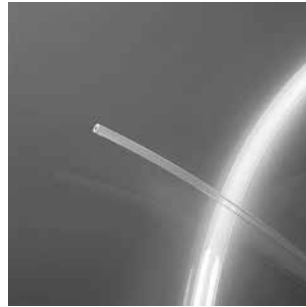
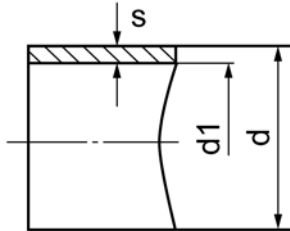

FEP-ROHRE

Type d / d1 x s	Mat.-Nr.	PN	d	d1	s	Tol. d	B.Radius	kg/100m
FEP 4/2.5x0.75, 50m	432.0095.005	22	4.00	2.50	0.75	±0.10	20	1.700
FEP 4/2x1, 50m	432.0100.003	37	4.00	2.00	1.00	±0.10	15	2.100
FEP 6/4x1, 50m	432.0200.003	18	6.00	4.00	1.00	±0.15	30	3.550
FEP 6/3x1.5, 50m	432.0205.003	37	6.00	3.00	1.50	±0.15	25	4.600
FEP 8/6x1, 50m	432.0300.003	12	8.00	6.00	1.00	±0.15	55	4.850
FEP 10/8x1, 50m	432.0350.003	9	10.00	8.00	1.00	±0.20	90	5.800
FEP 12/10x1, 50m	432.0400.003	8	12.00	10.00	1.00	±0.20	135	7.430
FEP 12/9x1,5, 50m	432.0405.003	13	12.00	9.00	1.50	±0.20	95	10.640

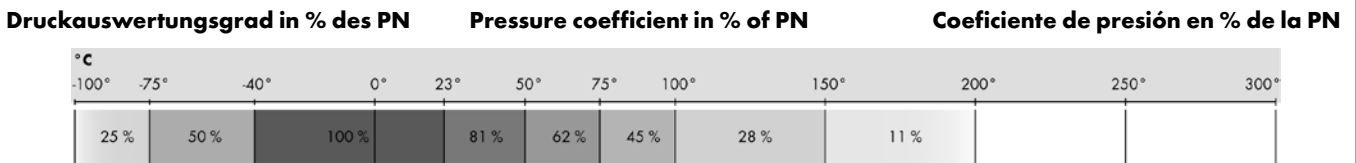

Spezifikationen:	Specifications:	Especificaciones:
<p>Werkstoff: Perfluorethylenpropylen, FDA-konform Temperaturbereich: -200°C bis +200°C Brandverhalten: gem. UL 94 V0 Härte: Shore D55 Berstdruck: 3-facher Betriebsdruck Farbe: natur Alle technischen Daten basieren auf den Herstellerangaben.</p>	<p>Material: Fluorinated ethylene propylene, FDA approved Temperature range: -200°C to +200°C Flammability: acc. to UL 94 V0 Hardness: Shore D55 Burst pressure: 3 x working pressure Colour: natural All technical data are based on manufacturer's specifications.</p>	<p>Material: Perfluoretileno/propileno, cumple la FDA Intervalo de temperatura: -200°C a +200°C Inflamabilidad: según UL 94 V0 Dureza: Shore D55 Presión de rotura: 3 x presión de servicio Color: natural Todos los datos técnicos se basan en las indicaciones del fabricante.</p>

Merkmale:	Characteristics:	Características:
<ul style="list-style-type: none"> - gute Temperaturbeständigkeit - gute Antihafteigenschaften, silikonfrei, sterilisierbar - elastischer als PTFE - geringe Permeabilität - dielektrische Eigenschaften, nicht leitfähig - UV- und witterungsbeständig - beständig gegen Sauerstoff und Ozon; Beständigkeitsliste siehe Anhang - Anwendungen: Pharma, Labor, Medizin, Lebensmittelindustrie, Halbleitertechnik 	<ul style="list-style-type: none"> - good temperature resistance - good non-stick properties, silicone-free, sterilisable - higher elasticity than PTFE - low permeability - dielectric properties, non-conductive - UV and weather resistant - resistant to oxygen and ozone; chemical resistance list see appendix - applications: pharmaceuticals, laboratory, medicine, food industry, semiconductor technology 	<ul style="list-style-type: none"> - buena resistencia a la temperatura - buena propiedades antiadherentes, sin silicona, esterilizable - más elástico que PTFE - baja permeabilidad - propiedades dieléctricas, no conductivo - resistente a los rayos UV y a la intemperie - resistente al oxígeno y al ozono; lista de resistencias, ver anexo - aplicaciones: farmacéutica, laboratorio, medicina, industria alimentaria, tecnología de semiconductores

PN=Arbeitsdruck bei +23°C
 B.Radius=min. Biegeradius
 d=Rohr außen-ø
 d1=Rohr innen-ø
 s=Wandstärke

PN=operation pressure at +23°C
 B.Radius=min. bending radius
 d=tube outside diameter
 d1=tube inside diameter
 s=wall thickness

PN=presión de trabajo a +23°C
 B.Radius=radio de curvatura min.
 d=ø exterior tubo
 d1=ø interior tubo
 s=grosor de pared

Perfluoralkoxy-Rohr (PFA)
Perfluoroalkoxy tube (PFA)
Tubo de perfluoroalcoxi (PFA)

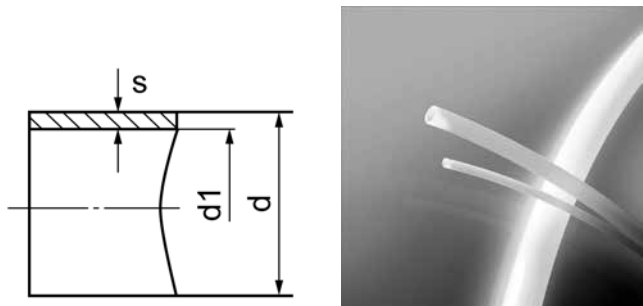

PFA-ROHRE

Type d / d1 x s	Mat.-Nr.	PN	d	d1	s	Tol. d	B.Radius	kg/100m
PFA 6/4x1, 100m	436.0200.003	23	6.00	4.00	1.00	±0.15	30	3.370
PFA 6/3x1.5, 100m	436.0205.003	46	6.00	3.00	1.50	±0.15	25	4.680
PFA 8/6x1, 100m	436.0300.003	15	8.00	6.00	1.00	±0.15	55	4.730

Druckauswertungsgrad in % des PN		Pressure coefficient in % of PN					Coeficiente de presión en % de la PN				
°C											
-100°	-75°	-40°	0°	23°	50°	75°	100°	150°	200°	250°	300°
25 %	50 %	100 %	86 %	61 %	50 %	36 %	25 %				

Spezifikationen:

Werkstoff: Perfluoralkoxy, FDA-konform
 Temperaturbereich: -200°C bis +200°C
 (kurzfristig: bis +260°C)
 Brandverhalten: gem. UL 94 V0
 Härte: Shore D60
 Berstdruck: 3-facher Betriebsdruck
 Farbe: natur
 Alle technischen Daten basieren auf den Herstellerangaben.

Specifications:

Material: Perfluoroalkoxy, FDA approved
 Temperature range: -200°C to +200°C
 (short term: +260°C)
 Flammability: acc. to UL 94 V0
 Hardness: Shore D60
 Burst pressure: 3 x working pressure
 Colour: natural
 All technical data are based on manufacturer's specifications.

Especificaciones:

Material: perfluoroalcoxi, cumple la FDA
 Intervalo de temperatura: -200°C a +200°C
 (brevemente: hasta +260°C)
 Inflamabilidad: según UL 94 V0
 Dureza: Shore D60
 Presión de rotura: 3 x presión de servicio
 Color: natural
 Todos los datos técnicos se basan en las indicaciones del fabricante.

Merkmale:

- gute Temperaturbeständigkeit
- gute Antihafteigenschaften, silikonfrei, sterilisierbar
- elastischer als PTFE
- geringe Permeabilität
- dielektrische Eigenschaften, nicht leitfähig
- UV- und witterungsbeständig
- beständig gegen Sauerstoff und Ozon;
 Beständigkeitsliste siehe Anhang
- Anwendungen: Pharma, Labor, Medizin, Lebensmittelindustrie, Halbleitertechnik

Characteristics:

- good temperature resistance
- good non-stick properties, silicone-free, sterilizable
- higher elasticity than PTFE
- low permeability
- dielectric properties, non-conductive
- UV and weather resistant
- resistant to oxygen and ozone;
 chemical resistance list see appendix
- applications: pharmaceuticals, laboratory, medicine, food industry, semiconductor technology

Características:

- buena resistencia a la temperatura
- buena propiedades antiadherentes, sin silicona, esterilizable
- más elástico que PTFE
- baja permeabilidad
- propiedades dieléctricas, no conductivo
- resistente a los rayos UV y a la intemperie
- resistente al oxígeno y al ozono;
 lista de resistencias, ver anexo
- aplicaciones: farmacéutica, laboratorio, medicina, industria alimentaria, tecnología de semiconductores

PN=Arbeitsdruck bei +23°C
 B.Radius=min. Biegeradius
 d=Rohr außen-ø
 d1=Rohr innen-ø
 s=Wandstärke

PN=operation pressure at +23°C
 B.Radius=min. bending radius
 d=tube outside diameter
 d1=tube inside diameter
 s=wall thickness

PN=presión de trabajo a +23°C
 B.Radius=radio de curvatura min.
 d=ø exterior tubo
 d1=ø interior tubo
 s=grosor de pared

SERTOflex-Rohr
SERTOflex tube
Tubo SERTOflex

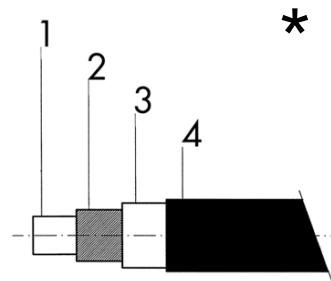
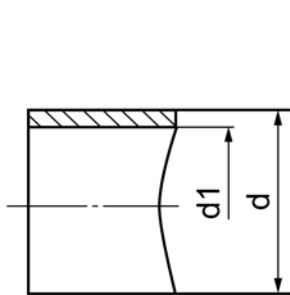

SERTO FLEX

Type -d	Mat.-Nr.	PN	d	d1	s	B.Radius	kg/100m
SERTOflex 6 S, 100m	440.1006.210	38	6.00	4.00	1.00	19	2.400
SERTOflex 6.35 S, 300m	440.1007.215	38	6.35	4.30	1.00	19	2.400
SERTOflex 8 S, 100m	440.1008.210	38	8.00	5.30	1.35	25	3.900
SERTOflex 10 S, 100m	440.1010.210	38	10.00	6.20	1.90	32	5.800
SERTOflex 12 S, 100m	440.1012.210	33	12.00	8.10	1.95	40	7.500
SERTOflex 14 S, 100m	440.1014.210	30	14.00	9.80	2.10	50	9.600
SERTOflex 15 S, 100m	440.1015.210	22	15.00	10.70	2.15	50	10.200

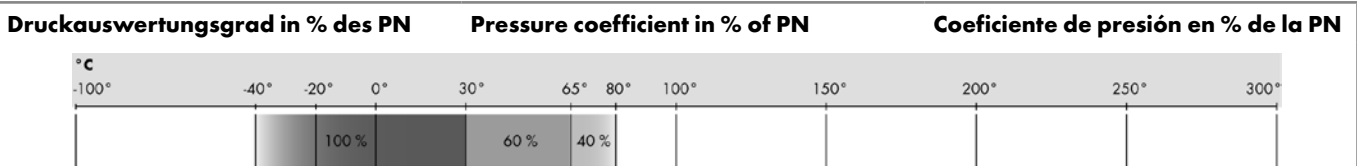

Spezifikationen:

Temperaturbereich: -40°C bis +80°C
 Farbe: schwarz
 Berstdruck: 3-facher Betriebsdruck
 Toleranz AD: +0.20/-0.35 mm
 Alle technischen Daten basieren auf den Herstellerangaben.

Kalibrierwerkzeug zu SERTOflex: siehe Kapitel Zubehör, Werkzeuge

Specifications:

Temperature range: -40°C to +80°C
 Colour: black
 Burst pressure: 3 x working pressure
 Tolerance outside Ø: +0.20/-0.35 mm
 All technical data are based on manufacturer's specifications.

Calibration tool for SERTOflex: see chapter Accessories, Tools

Especificaciones:

Intervalo de temperatura: -40°C a +80°C
 Color: negro
 Presión de rotura: 3 x presión de servicio
 Tolerancia Ø exterior: +0.20/-0.35 mm
 Todos los datos técnicos se basan en las indicaciones del fabricante.

Herramienta de calibrage per SERTOflex ver capítulo Accesorios, Utillajes

Merkmale:

- Mehrschichtrohr aus PE und Aluminium-Einlage
- von Hand verformbar
- formstabil, halogen- und silikonfrei
- geringes Gewicht bei hoher Stabilität
- Anwendungen: ausschließlich für pneumatische Steuer- und Prozessleitungen, vor allem in feuchter und nasser Umgebung

Characteristics:

- multilayer tube of PE and aluminium core
- can be bent manually
- stable in form, halogen and silicone free
- lightweight with high stability
- applications: exclusively for pneumatic control and process lines, especially in humid and wet environment

Características:

- tubo multicapa de PE y refuerzo interior de aluminio
- dúctil
- estabilidad de forma, sin halógenos y silicona
- poco peso y mucha resistencia
- aplicaciones: exclusivamente para tuberías de mando y procesos neumáticos, sobre todo en entornos húmedos y mojados

- * 1 Innere Beschichtung: PE
- 2 Einlage: Aluminium
- 3 Film: PE
- 4 Mantel: HD-PE

- 1 Internal coating: PE
- 2 Inlay: aluminium
- 3 Film: PE
- 4 Jacket: HD-PE

- 1 Revestimiento interior: PE
- 2 Refuerzo interior: aluminio
- 3 Lámina delgada: PE
- 4 Revestimiento externo: HD-PE

PN=Arbeitsdruck bei +23°C
 B.Radius=min. Biegeradius
 d=Rohr außen-Ø
 d1=Rohr innen-Ø
 s=Wandstärke

PN=operation pressure at +23°C
 B.Radius=min. bending radius
 d=tube outside diameter
 d1=tube inside diameter
 s=wall thickness

PN=presión de trabajo a +23°C
 B.Radius=radio de curvatura min.
 d=Ø exterior tubo
 d1=Ø interior tubo
 s=grosor de pared

70

Rohrschellen

Tube clamps

Abrazaderas de tubo



Seite/Page/Página

Seite/Page/Página

Schellenkörper PP, Serie A
Clamp body PP, series A
Cuerpo de la abrazadera PP, serie A

80.4-80.5



RS RGA-PP

Anschweißplatte kurz, Serie B
Weld-on plate short, series B
Chapa de soldadura corta, serie B

80.15



RS AKZ3B

Schellenkörper PA, Serie A
Clamp body PA, series A
Cuerpo de la abrazadera PA, serie A

80.6-80.7



RS RGA-PA

Deckplatte, Serie A
Cover plate, series A
Placa de cobertura, serie A

80.16-80.17



RS DPA

Schellenkörper PA flammh., Serie A
Clamp body PA flame ret., series A
Cuerpo de la abrazadera PA ignifugo, serie A

80.8



RS RGA-PA F

Deckplatte, Serie B
Cover plate, series B
Placa de cobertura, serie B

80.18



RS DPB

Schellenkörper Aluminium, Serie A
Clamp body aluminium, series A
Cuerpo de la abrazadera aluminio, serie A

80.9



RS RGA-AL

Sechskantschraube, Serie A
Hexagon screw, series A
Tornillo hexagonal, serie A

80.19-80.20



RS SSA

Schellenkörper PP, Serie B
Clamp body PP, series B
Cuerpo de la abrazadera PP, serie B

80.10



RS RGB-PP

Innensechskantschraube, Serie A
Hexagon socket screw, series A
Tornillo hexágono interior, serie A

80.21-80.22



RS ISA

Schellenkörper PA, Serie B
Clamp body PA, series B
Cuerpo de la abrazadera PA, serie B

80.11



RS RGB-PA

Aufbauschraube, Serie A
Stacking screw, serie A
Tornillo de apilamiento, serie A

80.23



RS ASA

Schellenkörper PA flammh., Serie B
Clamp body PA flame ret., series B
Cuerpo de la abrazadera PA ignifugo, serie B

80.12



RS RGB-PA F

Tragschiene, Serie A
Mounting rail, series A
Riel de soporte, serie A

80.24



RS TS

Anschweißplatte kurz, Serie A
Weld-on plate short, series A
Chapa de soldadura corta, serie A

80.13-80.14



RS AKZ1A

Tragschienenmutter, Serie A
Rail nut, series A
Tuerca de riel de soporte, serie A

80.25-80.26



RS TMA/TMVA

Rohrschellen

Tube clamps

Abrazaderas de tubo

Funktion

- Halten und Führen von Rohrleitungen
- Aufnahme von axialen und radialen Kräften
- Bewegungen verhindern oder dämpfen

Norm

leichte Baureihe Serie A/B, nach DIN 3015

Werkstoff

- Rohrschellen: PP, PA6, PA66 F, Aluminium
- Anschweißplatten: Stahl phosphatiert und Edelstahl 1.4401/1.4571
- Tragschienen: Stahl blank und Edelstahl 1.4401/1.4571
- Tragschienenmutter, Schrauben, Deckplatten: Stahl verzinkt und Edelstahl 1.4401/1.4571

Eigenschaften

PP Rohrschellen:

- -30°C bis +90°C
- leichter als Rohrschellen aus PA6
- Rohrhaltekräfte von 0.6 kN bis 2.3 kN
- Farbe: dunkelgrün

PA6 Rohrschellen:

- -40°C bis +120°C
- schwerer als Rohrschellen aus PP
- Rohrhaltekräfte von 0.6 kN bis 3.5 kN
- leicht flammhemmend
- Farbe: schwarz

PA66 F Rohrschellen:

- -40°C bis +120°C
- schwerer als Rohrschellen aus PP
- Rohrhaltekräfte von 0.6 kN bis 3.5 kN
- Erfüllung der Anforderungssätze R22 / R23 / R24 / R26 für die Gefährdungsstufen HL1-HL2-HL3 nach EN 45545-2
- Farbe: weiss-grau

Aluminium Rohrschellen:

- -40°C bis +300°C
- Rohrhaltekräfte von 3.5 kN bis 8.9 kN
- Farbe: grau

Function

- fixation and guidance of tubes
- absorption of axial and radial forces
- to absorb or prevent movement

Norm

light series A/B, according to DIN 3015

Material

- tube clamps: PP, PA6, PA66 F, aluminium
- weld-on plates: steel phosphatized or stainless steel 1.4401/1.4571
- mounting rails: bright steel or stainless steel 1.4401/1.4571
- rail nuts, screws, cover plates: zinc-plated steel or stainless steel 1.4401/1.4571

Characteristics

Tube clamps made of PP:

- -30°C to +90°C
- lighter than tube clamps made of PA6
- tube holding power 0.6 kN to 2.3 kN
- color: dark green

Tube clamps made of PA6:

- -40°C to +120°C
- heavier than tube clamps made of PP
- tube holding power 0.6 kN to 3.5 kN
- slightly flame retardant
- color: black

Tube clamps made of PA66 F:

- -40°C to +120°C
- heavier than tube clamps made of PP
- tube holding power 0.6 kN to 3.5 kN
- fulfilment of the requirement sets R22 / R23 / R24 / R26 for the hazard levels HL1-HL2-HL3 according to EN 45545-2
- color: white-grey

Tube clamps made of aluminium:

- -40°C to +300°C
- tube holding power 3.5 kN to 8.9 kN
- color: grey

Función

- fijación y guía de tubos
- absorción de fuerzas axiales y radiales
- prevenir o amortiguar los movimientos

Norma

serie ligera A/B, según DIN 3015

Material

- abrazaderas de tubo: PP, PA6, PA66 F aluminio
- chapas de soldadura: acero fosfatado y acero inoxidable 1.4401/1.4571
- rieles de soporte: acero brillante y acero inoxidable 1.4401/1.4571
- tuercas para rieles de montaje, tornillos, placas de cobertura: acero galvanizado y acero inoxidable 1.4401/1.4571

Propiedades

Abrazaderas de tubo de PP:

- -30 °C a +90 °C
- más ligeras que las abrazaderas de tubo de PA6
- fuerzas de retención del tubo de 0,6 a 2,3 kN
- color: verde oscuro

Abrazaderas de tubo de PA6:

- -40°C a +120°C
- más pesadas que las abrazaderas de tubo de PP
- fuerzas de retención del tubo de 0,6 a 3.5 kN
- ligeramente piroretardante
- color: negro

Abrazaderas de tubo de PA66 F:

- -40°C a +120°C
- más pesadas que las abrazaderas de tubo de PP
- fuerzas de retención del tubo de 0,6 a 3.5 kN
- el cumplimiento de los conjuntos de requisitos R22 / R23 / R24 / R26 para los niveles de peligro HL1-HL2-HL3 según EN 45545-2
- color: blanco-grisáceo

Abrazaderas de tubo de aluminio:

- -40°C a +300°C
- fuerzas de retención del tubo de 3.5 a 8.9 kN
- color: gris

Chemische Beständigkeit

Chemical resistance

Resistencia química

	PP Rohrschellen Tube clamps PP Abrazaderas de tubo PP	PA Rohrschellen Tube clamps PA Abrazaderas de tubo PA	Aluminium Rohrschellen Tube clamps aluminium Abrazaderas de tubo aluminio
Säuren acids ácidos	bedingt beständig limited resistance resistencia condicionada	bedingt beständig limited resistance resistencia condicionada	bedingt beständig limited resistance resistencia condicionada
Laugen alkalis lejías	bedingt beständig limited resistance resistencia condicionada	bedingt beständig limited resistance resistencia condicionada	bedingt beständig limited resistance resistencia condicionada
Alkohole alcohols alcoholes	beständig resistant resistente	beständig resistant resistente	beständig resistant resistente
Benzin gasoline gasolina	bedingt beständig limited resistance resistencia condicionada	beständig resistant resistente	beständig resistant resistente
Mineralöl mineral oil aceites minerales	bedingt beständig limited resistance resistencia condicionada	beständig resistant resistente	beständig resistant resistente
sonstige Öle other oils otros aceites	beständig resistant resistente	beständig resistant resistente	beständig resistant resistente

Schellenkörper

PP, Serie A

Clamp body

PP, series A

Cuerpo de la abrazadera

PP, serie A

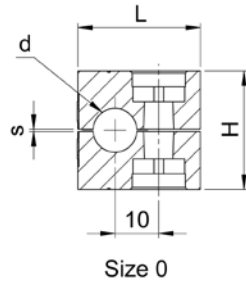
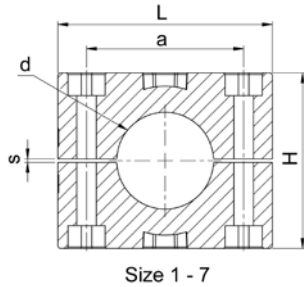

RS RGA-PP

Type-S-d	Mat.-Nr.	d (")	L	H	a	s	kg/100
RS RGA-PP-0-4	906.1000.004	-	28.0	27.0	0.0	0.60	0.990
RS RGA-PP-0-6	906.1000.006	-	28.0	27.0	0.0	0.60	0.850
RS RGA-PP-0-6.4	906.1000.007	1/4	28.0	27.0	0.0	0.60	1.020
RS RGA-PP-0-8	906.1000.008	5/16	28.0	27.0	0.0	0.60	0.950
RS RGA-PP-0-9.5	906.1000.009	3/8	28.0	27.0	0.0	0.60	0.850
RS RGA-PP-0-10	906.1000.010	-	28.0	27.0	0.0	0.60	0.940
RS RGA-PP-0-12	906.1000.012	-	28.0	27.0	0.0	0.60	0.890
RS RGA-PP-1-6	906.1000.106	-	34.0	27.0	20.0	0.60	1.360
RS RGA-PP-1-6.4	906.1000.107	1/4	34.0	27.0	20.0	0.60	1.190
RS RGA-PP-1-8	906.1000.108	5/16	34.0	27.0	20.0	0.60	1.230
RS RGA-PP-1-9.5	906.1000.109	3/8	34.0	27.0	20.0	0.60	1.340
RS RGA-PP-1-10	906.1000.110	-	34.0	27.0	20.0	0.60	1.160
RS RGA-PP-1-12	906.1000.112	-	34.0	27.0	20.0	0.60	1.300
RS RGA-PP-2-12.7	906.1000.212	1/2	42.0	33.0	26.0	0.80	1.740
RS RGA-PP-2-13.5	906.1000.213	-	42.0	33.0	26.0	0.80	1.690
RS RGA-PP-2-14	906.1000.214	-	42.0	33.0	26.0	0.80	1.650
RS RGA-PP-2-15	906.1000.215	-	42.0	33.0	26.0	0.80	1.610
RS RGA-PP-2-16	906.1000.216	5/8	42.0	33.0	26.0	0.80	1.640
RS RGA-PP-2-17.2	906.1000.217	-	42.0	33.0	26.0	0.80	1.540
RS RGA-PP-2-18	906.1000.218	-	42.0	33.0	26.0	0.80	1.500
RS RGA-PP-3-19	906.1000.319	3/4	49.0	35.0	33.0	1.00	1.770
RS RGA-PP-3-20	906.1000.320	-	49.0	35.0	33.0	1.00	1.830
RS RGA-PP-3-21.3	906.1000.321	-	49.0	35.0	33.0	1.00	1.870
RS RGA-PP-3-22	906.1000.322	-	49.0	35.0	33.0	1.00	1.840
RS RGA-PP-3-23	906.1000.323	-	49.0	35.0	33.0	1.00	1.810
RS RGA-PP-3-25	906.1000.325	-	49.0	35.0	33.0	1.00	1.940
RS RGA-PP-3-25.4	906.1000.326	1	49.0	35.0	33.0	1.00	1.700
RS RGA-PP-4-26.9	906.1000.426	-	59.0	42.0	40.0	1.20	2.700
RS RGA-PP-4-28	906.1000.428	-	59.0	42.0	40.0	1.20	2.590
RS RGA-PP-4-30	906.1000.430	-	59.0	42.0	40.0	1.20	2.530

Fortsetzung nächste Seite

Continued on next page

Continuación página próxima

d=Rohr außen-
d (")=d=Rohr außen-
S=Schellengröße

d=tube outside diameter
d (")=tube outside diameter inch
S=size of clamp

d=ø exterior tubo
d (")=ø exterior tubo inglesa
S=tamaño de abrazadera

Schellenkörper

PP, Serie A

Clamp body

PP, series A

Cuerpo de la abrazadera

PP, serie A

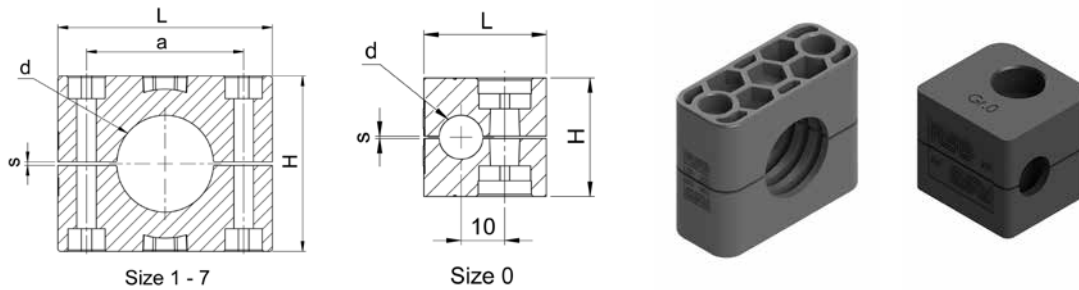

RS RGA-PP

Type-S-d	Mat.-Nr.	d (")	L	H	a	s	kg/100
RS RGA-PP-5-32	906.1000.532	1 1/4	71.0	58.0	52.0	1.20	4.780
RS RGA-PP-5-33.7	906.1000.533	-	71.0	58.0	52.0	1.20	4.760
RS RGA-PP-5-35	906.1000.535	-	71.0	58.0	52.0	1.20	4.780
RS RGA-PP-5-38	906.1000.538	1 1/2	71.0	58.0	52.0	1.20	4.320
RS RGA-PP-5-40	906.1000.540	-	71.0	58.0	52.0	1.20	4.250
RS RGA-PP-5-42	906.1000.542	-	71.0	58.0	52.0	1.20	4.030
RS RGA-PP-6-44.5	906.1000.644	1 3/4	86.0	66.0	66.0	1.20	5.970
RS RGA-PP-6-45	906.1000.645	-	86.0	66.0	66.0	1.20	5.940
RS RGA-PP-6-48	906.1000.648	-	86.0	66.0	66.0	1.20	5.600
RS RGA-PP-6-50	906.1000.650	-	86.0	66.0	66.0	1.20	5.510
RS RGA-PP-6-50.8	906.1000.651	2	86.0	66.0	66.0	1.20	5.330
RS RGA-PP-6-52	906.1000.652	-	86.0	66.0	66.0	1.20	5.180
RS RGA-PP-6-54	906.1000.654	-	86.0	66.0	66.0	1.20	5.840
RS RGA-PP-6-55	906.1000.655	-	86.0	66.0	66.0	1.20	4.750
RS RGA-PP-6-57	906.1000.657	-	86.0	66.0	66.0	1.20	4.520
RS RGA-PP-7-57.2	906.1000.757	2 1/4	121.0	93.6	94.0	1.60	13.600
RS RGA-PP-7-60.3	906.1000.760	-	121.0	93.6	94.0	1.60	13.650
RS RGA-PP-7-63.5	906.1000.763	2 1/2	121.0	93.6	94.0	1.60	12.550
RS RGA-PP-7-70	906.1000.770	2 3/4	121.0	93.6	94.0	1.60	12.100
RS RGA-PP-7-73	906.1000.773	-	121.0	93.6	94.0	1.60	14.000
RS RGA-PP-7-76.1	906.1000.776	3	121.0	93.6	94.0	1.60	10.950

Lieferung nur in Einheitspackungen:
Größen 0 bis 6 = Beutel à 25 Stk.
Größe 7 = Beutel à 10 Stk.

Delivery in packing units only:
Sizes 0 to 6 = Bags with 25 pcs.
Size 7 = Bags with 10 pcs.

Suministro únicamente en paquetes unitarios:
Tamaños 0 a 6 = Bolsas de 25 pzs.
Tamaño 7 = Bolsas de 10 pzs.

d=Rohr außen-
d (")=d=Rohr außen-
S=Schellengröße

d=tube outside diameter
d (")=tube outside diameter inch
S=size of clamp

d=ø exterior tubo
d (")=ø exterior tubo inglesa
S=tamaño de abrazadera

Schellenkörper

PA, Serie A

Clamp body

PA, series A

Cuerpo de la abrazadera

PA, serie A

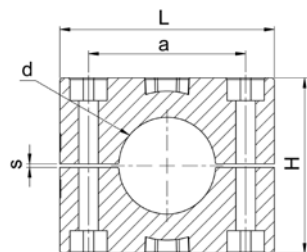

Size 1 - 7

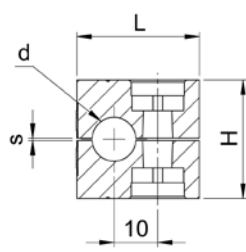

Size 0



RS RGA-PA

Type-S-d	Mat.-Nr.	d (")	L	H	a	s	kg/100
RS RGA-PA-0-4	906.2000.004	-	28.0	27.0	0.0	0.60	1.300
RS RGA-PA-0-6	906.2000.006	-	28.0	27.0	0.0	0.60	1.200
RS RGA-PA-0-6.4	906.2000.007	1/4	28.0	27.0	0.0	0.60	0.900
RS RGA-PA-0-8	906.2000.008	5/16	28.0	27.0	0.0	0.60	1.200
RS RGA-PA-0-9.5	906.2000.009	3/8	28.0	27.0	0.0	0.60	0.900
RS RGA-PA-0-10	906.2000.010	-	28.0	27.0	0.0	0.60	1.150
RS RGA-PA-0-12	906.2000.012	-	28.0	27.0	0.0	0.60	1.110
RS RGA-PA-1-6	906.2000.106	-	34.0	27.0	20.0	0.60	1.660
RS RGA-PA-1-6.4	906.2000.107	1/4	34.0	27.0	20.0	0.60	1.600
RS RGA-PA-1-8	906.2000.108	5/16	34.0	27.0	20.0	0.60	1.520
RS RGA-PA-1-9.5	906.2000.109	3/8	34.0	27.0	20.0	0.60	1.670
RS RGA-PA-1-10	906.2000.110	-	34.0	27.0	20.0	0.60	1.620
RS RGA-PA-1-12	906.2000.112	-	34.0	27.0	20.0	0.60	1.360
RS RGA-PA-2-12.7	906.2000.212	1/2	42.0	33.0	26.0	0.80	2.200
RS RGA-PA-2-13.5	906.2000.213	-	42.0	33.0	26.0	0.80	2.150
RS RGA-PA-2-14	906.2000.214	-	42.0	33.0	26.0	0.80	1.960
RS RGA-PA-2-15	906.2000.215	-	42.0	33.0	26.0	0.80	2.010
RS RGA-PA-2-16	906.2000.216	5/8	42.0	33.0	26.0	0.80	1.890
RS RGA-PA-2-17.2	906.2000.217	-	42.0	33.0	26.0	0.80	2.100
RS RGA-PA-2-18	906.2000.218	-	42.0	33.0	26.0	0.80	1.820
RS RGA-PA-3-19	906.2000.319	3/4	49.0	35.0	33.0	1.00	2.430
RS RGA-PA-3-20	906.2000.320	-	49.0	35.0	33.0	1.00	2.630
RS RGA-PA-3-21.3	906.2000.321	-	49.0	35.0	33.0	1.00	2.390
RS RGA-PA-3-22	906.2000.322	-	49.0	35.0	33.0	1.00	2.310
RS RGA-PA-3-23	906.2000.323	-	49.0	35.0	33.0	1.00	2.160
RS RGA-PA-3-25	906.2000.325	-	49.0	35.0	33.0	1.00	2.090
RS RGA-PA-3-25.4	906.2000.326	1	49.0	35.0	33.0	1.00	2.080
RS RGA-PA-4-26.9	906.2000.426	-	59.0	42.0	40.0	1.20	3.400
RS RGA-PA-4-28	906.2000.428	-	59.0	42.0	40.0	1.20	3.210
RS RGA-PA-4-30	906.2000.430	-	59.0	42.0	40.0	1.20	3.140

Fortsetzung nächste Seite

Continued on next page

Continuación página próxima

d=Rohr außen-
d (")=d=Rohr außen-
S=Schellengröße

d=tube outside diameter
d (")=tube outside diameter inch
S=size of clamp

d=ø exterior tubo
d (")=ø exterior tubo inglesa
S=tamaño de abrazadera

Schellenkörper

PA, Serie A

Clamp body

PA, series A

Cuerpo de la abrazadera

PA, serie A

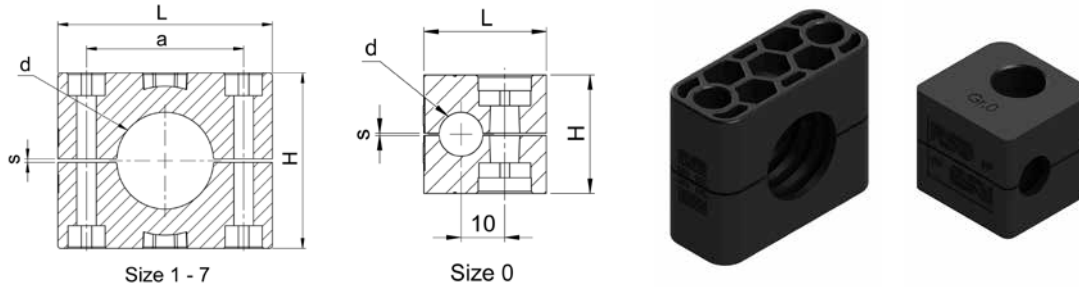

RS RGA-PA

Type-S-d	Mat.-Nr.	d (")	L	H	a	s	kg/100
RS RGA-PA-5-32	906.2000.532	1 1/4	71.0	58.0	52.0	1.20	5.900
RS RGA-PA-5-33.7	906.2000.533	-	71.0	58.0	52.0	1.20	5.570
RS RGA-PA-5-35	906.2000.535	-	71.0	58.0	52.0	1.20	5.640
RS RGA-PA-5-38	906.2000.538	1 1/2	71.0	58.0	52.0	1.20	5.390
RS RGA-PA-5-40	906.2000.540	-	71.0	58.0	52.0	1.20	5.030
RS RGA-PA-5-42	906.2000.542	-	71.0	58.0	52.0	1.20	4.750
RS RGA-PA-6-44.5	906.2000.644	1 3/4	86.0	66.0	66.0	1.20	7.500
RS RGA-PA-6-45	906.2000.645	-	86.0	66.0	66.0	1.20	7.500
RS RGA-PA-6-48	906.2000.648	-	86.0	66.0	66.0	1.20	7.950
RS RGA-PA-6-50	906.2000.650	-	86.0	66.0	66.0	1.20	6.450
RS RGA-PA-6-50.8	906.2000.651	2	86.0	66.0	66.0	1.20	6.430
RS RGA-PA-6-52	906.2000.652	-	86.0	66.0	66.0	1.20	7.440
RS RGA-PA-6-54	906.2000.654	-	86.0	66.0	66.0	1.20	6.150
RS RGA-PA-6-55	906.2000.655	-	86.0	66.0	66.0	1.20	7.500
RS RGA-PA-6-57	906.2000.657	-	86.0	66.0	66.0	1.20	7.500
RS RGA-PA-7-57.2	906.2000.757	2 1/4	121.0	93.6	94.0	1.60	17.200
RS RGA-PA-7-60.3	906.2000.760	-	121.0	93.6	94.0	1.60	16.100
RS RGA-PA-7-63.5	906.2000.763	2 1/2	121.0	93.6	94.0	1.60	16.300
RS RGA-PA-7-70	906.2000.770	2 3/4	121.0	93.6	94.0	1.60	14.000
RS RGA-PA-7-73	906.2000.773	-	121.0	93.6	94.0	1.60	14.000
RS RGA-PA-7-76.1	906.2000.776	3	121.0	93.6	94.0	1.60	14.000

Lieferung nur in Einheitspackungen:
Größen 0 bis 6 = Beutel à 25 Stk.
Größe 7 = Beutel à 10 Stk.

Delivery in packing units only:
Sizes 0 to 6 = Bags with 25 pcs.
Size 7 = Bags with 10 pcs.

Suministro únicamente en paquetes unitarios:
Tamaños 0 a 6 = Bolsas de 25 pzs.
Tamaño 7 = Bolsas de 10 pzs.

Schellenkörper

PA flammhemmend, Serie A

Clamp body

PA flame retardant, series A

Cuerpo de la abrazadera

PA ignifugo, serie A

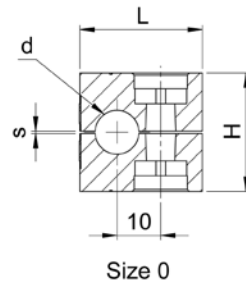
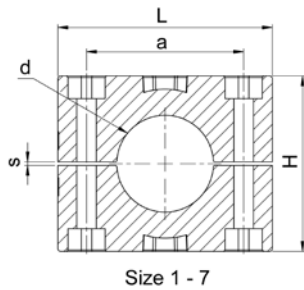

RS RGA PA F

Type-S-d	Mat.-Nr.	d (")	L	H	a	s	kg/100
RS RGA-PA-0-10 F	906.2000.010.F	-	28.0	27.0	0.0	0.60	1.150
RS RGA-PA-1-8 F	906.2000.108.F	5/16	34.0	27.0	20.0	0.60	1.520
RS RGA-PA-1-10 F	906.2000.110.F	-	34.0	27.0	20.0	0.60	1.620
RS RGA-PA-2-18 F	906.2000.218.F	-	42.0	33.0	26.0	0.80	1.820
RS RGA-PA-3-19 F	906.2000.319.F	3/4	49.0	35.0	33.0	1.00	2.430
RS RGA-PA-3-22 F	906.2000.322.F	-	49.0	35.0	33.0	1.00	2.310

Lieferung nur in Einheitspackungen = Beutel à 25 Stk.

Delivery in packing units only = bags with 25 pcs.

Suministro únicamente en paquetes unitarios = bolsas de 25 pzs.

d=Rohr außen-ø
d (")=d=Rohr außen-ø zoll
S=Schellengröße

d=tube outside diameter
d (")=tube outside diameter inch
S=size of clamp

d=ø exterior tubo
d (")=ø exterior tubo inglesa
S=tamaño de abrazadera

Schellenkörper

Aluminium, Serie A

Clamp body

aluminium, series A

Cuerpo de la abrazadera

aluminio, serie A

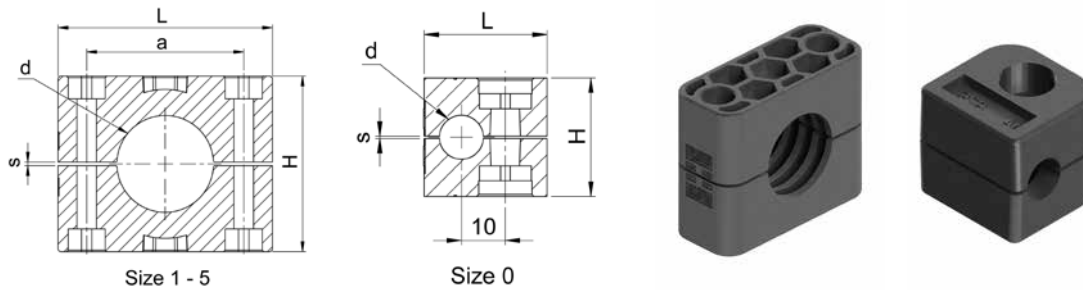

RS RGA-AL

Type-S-d	Mat.-Nr.	d (")	L	H	a	s	kg/100
RS RGA-AL-0-10	906.7000.010	-	28.0	27.0	0.0	0.60	4.020
RS RGA-AL-0-12	906.7000.012	-	28.0	27.0	0.0	0.60	3.800
RS RGA-AL-1-6	906.7000.106	-	34.0	27.0	20.0	0.60	3.750
RS RGA-AL-1-8	906.7000.108	5/16	34.0	27.0	20.0	0.60	3.420
RS RGA-AL-1-10	906.7000.110	-	34.0	27.0	20.0	0.60	3.310
RS RGA-AL-1-12	906.7000.112	-	34.0	27.0	20.0	0.60	3.160
RS RGA-AL-2-15	906.7000.215	-	42.0	33.0	26.0	0.80	5.550
RS RGA-AL-2-18	906.7000.218	-	42.0	33.0	26.0	0.80	5.300
RS RGA-AL-3-22	906.7000.322	-	49.0	35.0	33.0	1.00	5.820
RS RGA-AL-3-25	906.7000.325	-	49.0	35.0	33.0	1.00	5.380
RS RGA-AL-4-28	906.7000.428	-	59.0	42.0	40.0	1.20	7.510
RS RGA-AL-5-35	906.7000.535	-	71.0	58.0	52.0	1.20	14.130
RS RGA-AL-5-42	906.7000.542	-	71.0	58.0	52.0	1.20	12.150

Lieferung nur in Einheitspackungen = Beutel à 25 Stk.

Delivery in packing units only = bags with 25 pcs.

Suministro únicamente en paquetes unitarios = bolsas de 25 pzs.

d=Rohr außen-Ø
d (")=d=Rohr außen-Ø zoll
S=Schellengröße

d=tube outside diameter
d (")=tube outside diameter inch
S=size of clamp

d=Ø exterior tubo
d (")=Ø exterior tubo inglesa
S=tamaño de abrazadera

Schellenkörper

PP, Serie B (Zweirohrschellen)

Clamp body

PP, series B (twin-tube clamp)

Cuerpo de la abrazadera

PP, serie B (abrazaderos de dos tubos)

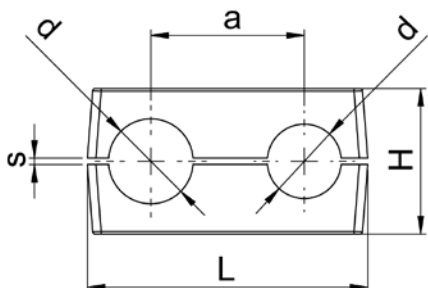

RS RGB-PP

Type-S-d	Mat.-Nr.	L	H	a	s	kg/100
RS RGB-PP-1-6	916.1000.106	36.0	27.0	20.0	1.00	1.330
RS RGB-PP-1-10	916.1000.110	36.0	27.0	20.0	1.00	1.230
RS RGB-PP-1-12	916.1000.112	36.0	27.0	20.0	1.00	1.130

Lieferung nur in Einheitspackungen = Beutel à 25 Stk.

Delivery in packing units only = bags with 25 pcs.

Suministro únicamente en paquetes unitarios = bolsas de 25 pzs.

d=Rohr außen-ø
 d (")=d=Rohr außen-ø zoll
 S=Schellengröße

d=tube outside diameter
 d (")=tube outside diameter inch
 S=size of clamp

d=ø exterior tubo
 d (")=ø exterior tubo inglesa
 S=tamaño de abrazadera

Schellenkörper

PA, Serie B (Zweirohrschellen)

Clamp body

PA, series B (twin-tube clamp)

Cuerpo de la abrazadera

PA, serie B (abrazaderos de dos tubos)

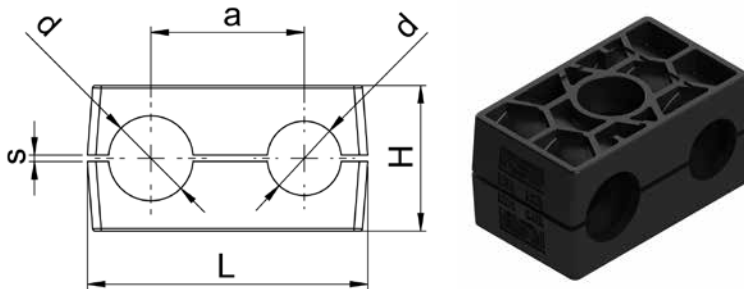

RS RGB-PA

Type-S-d	Mat.-Nr.	L	H	a	s	kg/100
RS RGB-PA-1-6	916.2000.106	36.0	27.0	20.0	1.00	1.680
RS RGB-PA-1-10	916.2000.110	36.0	27.0	20.0	1.00	1.540
RS RGB-PA-2-15	916.2000.215	53.0	27.4	29.0	1.20	2.160
RS RGB-PA-2-18	916.2000.218	53.0	27.4	29.0	1.20	1.800
RS RGB-PA-4-28	916.2000.428	82.0	42.0	52.0	2.00	3.980
RS RGB-PA-5-35	916.2000.535	106.0	54.0	56.0	2.00	7.200

Lieferung nur in Einheitspackungen = Beutel à 25 Stk.

Delivery in packing units only = bags with 25 pcs.

Suministro únicamente en paquetes unitarios = bolsas de 25 pzs.

d=Rohr außen-ø
d (")=d=Rohr außen-ø zoll
S=Schellengröße

d=tube outside diameter
d (")=tube outside diameter inch
S=size of clamp

d=ø exterior tubo
d (")=ø exterior tubo inglesa
S=tamaño de abrazadera

Schellenkörper

PA flammhemmend, Serie B (Zweirohrschellen)

Clamp body

PA flame retardant, series B (twin-tube clamp)

Cuerpo de la abrazadera

PA ignifugo, serie B (abrazaderos de dos tubos)

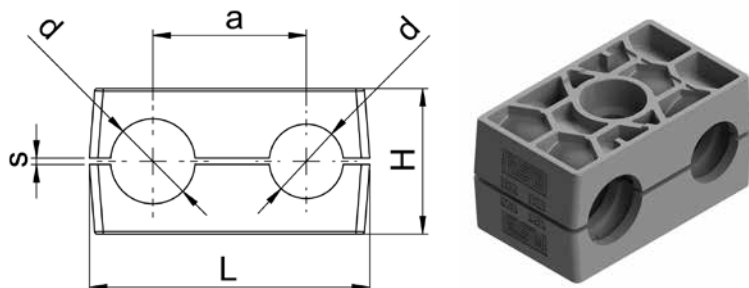

RS RGB-PA F

Type-S-d	Mat.-Nr.	d (")	L	H	a	s	kg/100
RS RGB-PA-1-8 F	916.2000.108.F	5/16	36.0	27.0	20.0	1.00	1.540
RS RGB-PA-1-10 F	916.2000.110.F	-	36.0	27.0	20.0	1.00	1.540
RS RGB-PA-1-12 F	916.2000.112.F	-	36.0	27.0	20.0	1.00	1.600
RS RGB-PA-2-15 F	916.2000.215.F	-	53.0	27.4	29.0	1.20	2.160
RS RGB-PA-4-28 F	916.2000.428.F	-	82.0	42.0	52.0	2.00	3.980
RS RGB-PA-5-35 F	916.2000.535.F	-	106.0	54.0	56.0	2.00	7.200

Lieferung nur in Einheitspackungen = Beutel à 25 Stk.

Delivery in packing units only = bags with 25 pcs.

Suministro únicamente en paquetes unitarios = bolsas de 25 pzs.

d=Rohraussen-ø
d (")=d=Rohraussen-ø zoll
S=Schellengröße

d=tube outside diameter
d (")=tube outside diameter inch
S=size of clamp

d=ø exterior tubo
d (")=ø exterior tubo inglesa
S=tamaño de abrazadera

Anschweisplatte kurz

Stahl phosphatiert, Serie A

Weld-on plate short

steel phosphatized, series A

Chapa de soldadura corta

acero fosfatado, serie A

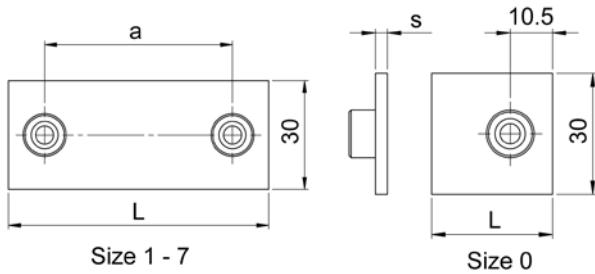

RS AKZ1A-SB

Type-S	Mat.-Nr.	L	a	s	kg/100
RS AKZ1A-SB-0	946.3108.000	30.0	0.0	3.00	2.400
RS AKZ1A-SB-1	946.3108.100	36.0	20.0	3.00	3.200
RS AKZ1A-SB-2	946.3108.200	42.0	26.0	3.00	3.600
RS AKZ1A-SB-3	946.3108.300	50.0	33.0	3.00	4.100
RS AKZ1A-SB-4	946.3108.400	59.0	40.0	3.00	4.800
RS AKZ1A-SB-5	946.3108.500	72.0	52.0	3.00	5.400
RS AKZ1A-SB-6	946.3108.600	88.0	66.0	3.00	6.000
RS AKZ1A-SB-7	946.3108.700	122.0	94.0	5.00	14.000

Lieferung nur in Einheitspackungen:
Größen 0 bis 6 = Beutel à 25 Stk.
Größe 7 = Beutel à 10 Stk.

Delivery in packing units only:
Sizes 0 to 6 = Bags with 25 pcs.
Size 7 = Bags with 10 pcs.

Suministro únicamente en paquetes unitarios:
Tamaños 0 a 6 = Bolsas de 25 pzs.
Tamaño 7 = Bolsas de 10 pzs.

Anschweisplatte kurz

Edelstahl 1.4571/1.4401, Serie A

Weld-on plate short

stainless steel 1.4571/1.4401, series A

Chapa de soldadura corta

acero inoxidable 1.4571/1.4401, serie A

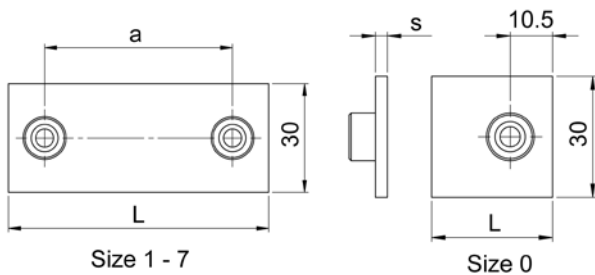

RS AKZ2A-E1

Type-S	Mat.-Nr.	L	a	s	kg/100
RS AKZ2A-E1-0	946.5118.000	30.0		3.00	2.200
RS AKZ2A-E1-1	946.5118.100	36.0	20.0	3.00	2.500
RS AKZ2A-E1-2	946.5118.200	42.0	26.0	3.00	2.900
RS AKZ2A-E1-3	946.5118.300	50.0	33.0	3.00	3.500
RS AKZ2A-E1-4	946.5118.400	59.0	40.0	3.00	4.000
RS AKZ2A-E1-5	946.5118.500	72.0	52.0	3.00	4.900
RS AKZ2A-E1-6	946.5118.600	88.0	66.0	3.00	6.300
RS AKZ2A-E1-7	946.5118.700	122.0	94.0	5.00	14.600

Lieferung nur in Einheitspackungen:
Größen 0 bis 6 = Beutel à 25 Stk.
Größe 7 = Beutel à 10 Stk.

Delivery in packing units only:
Sizes 0 to 6 = Bags with 25 pcs.
Size 7 = Bags with 10 pcs.

Suministro únicamente en paquetes unitarios:
Tamaños 0 a 6 = Bolsas de 25 pzs.
Tamaño 7 = Bolsas de 10 pzs.

Anschweisplatte kurz

mit Verdrehsicherung, Edelstahl 1.4571/1.4401, Serie B

Weld-on plate short

with torsion lock, stainless steel 1.4571/1.4401, series B

Chapa de soldadura corta

con bloqueo de torsión, acero inoxidable 1.4571/1.4401, serie B

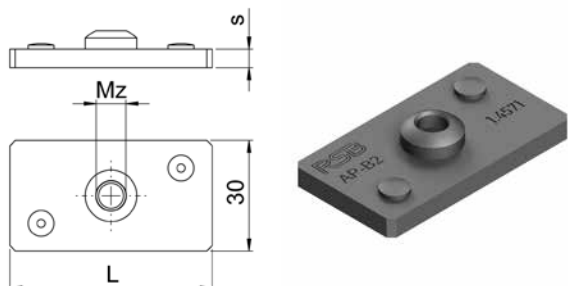

RS AKZ3B-E1

Type-S	Mat.-Nr.	Mz	L	s	kg/100
RS AKZ3B-E1-1	956.5118.100	M6	37.0	3.00	2.620
RS AKZ3B-E1-2	956.5118.200	M8	55.0	5.00	6.200
RS AKZ3B-E1-3	956.5118.300	M8	70.0	5.00	7.900
RS AKZ3B-E1-4	956.5118.400	M8	85.0	5.00	9.800
RS AKZ3B-E1-5	956.5118.500	M8	110.0	5.00	12.600

Lieferung nur in Einheitspackungen = Beutel à 25 Stk.

Delivery in packing units only = bags with 25 pcs.

Suministro únicamente en paquetes unitarios = bolsas de 25 pzs.

Deckplatte

Stahl verzinkt, Serie A

Cover plate

zinc-plated steel, series A

Placa de cobertura

acero galvanizado, serie A

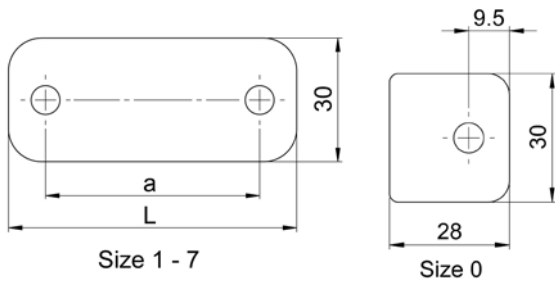

RS DPA-VZ

Type-S	Mat.-Nr.	L	a	kg/100
RS DPA-VZ-0	946.4130.000	28.0	0.0	1.700
RS DPA-VZ-1	946.4130.100	34.0	20.0	2.100
RS DPA-VZ-2	946.4130.200	40.0	26.0	2.500
RS DPA-VZ-3	946.4130.300	48.0	33.0	3.100
RS DPA-VZ-4	946.4130.400	57.0	40.0	3.700
RS DPA-VZ-5	946.4130.500	70.0	52.0	4.600
RS DPA-VZ-6	946.4130.600	86.0	66.0	5.700
RS DPA-VZ-7	946.4130.700	120.0	94.0	14.000

Lieferung nur in Einheitspackungen:
Größen 0 bis 6 = Beutel à 25 Stk.
Größe 7 = Beutel à 10 Stk.

Delivery in packing units only:
Sizes 0 to 6 = Bags with 25 pcs.
Size 7 = Bags with 10 pcs.

Suministro únicamente en paquetes unitarios:
Tamaños 0 a 6 = Bolsas de 25 pzs.
Tamaño 7 = Bolsas de 10 pzs.

Deckplatte

Edelstahl 1.4571/1.4401, Serie A

Cover plate

stainless steel 1.4571/1.4401, series A

Placa de cobertura

acero inoxidable 1.4571/1.4401, serie A

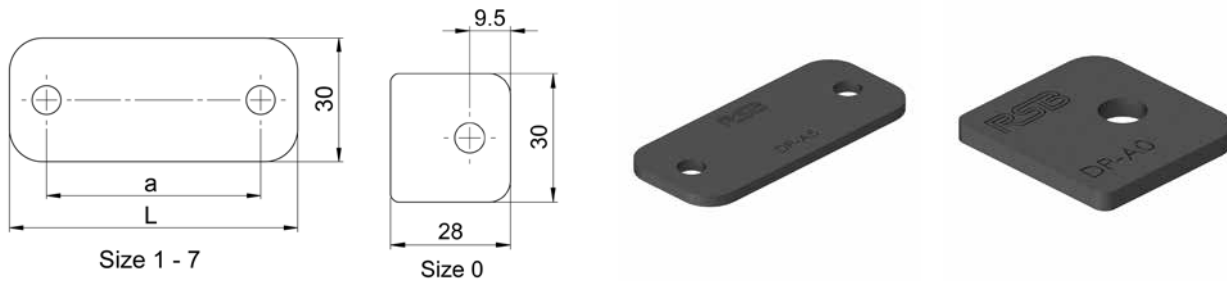

RS DPA-E1

Type-S	Mat.-Nr.	L	a	kg/100
RS DPA-E1-0	946.5130.000	28.0	0.0	1.900
RS DPA-E1-1	946.5130.100	34.0	20.0	2.000
RS DPA-E1-2	946.5130.200	40.0	26.0	2.400
RS DPA-E1-3	946.5130.300	48.0	33.0	3.100
RS DPA-E1-4	946.5130.400	57.0	40.0	3.600
RS DPA-E1-5	946.5130.500	70.0	52.0	4.000
RS DPA-E1-6	946.5130.600	86.0	66.0	5.800
RS DPA-E1-7	946.5130.700	120.0	94.0	13.400

Lieferung nur in Einheitspackungen:
Größen 0 bis 6 = Beutel à 25 Stk.
Größe 7 = Beutel à 10 Stk.

Delivery in packing units only:
Sizes 0 to 6 = Bags with 25 pcs.
Size 7 = Bags with 10 pcs.

Suministro únicamente en paquetes unitarios:
Tamaños 0 a 6 = Bolsas de 25 pzs.
Tamaño 7 = Bolsas de 10 pzs.

Deckplatte

Edelstahl 1.4571/1.4401, Serie B

Cover plate

stainless steel 1.4571/1.4401, series B

Placa de cobertura

acero inoxidable 1.4571/1.4401, serie B

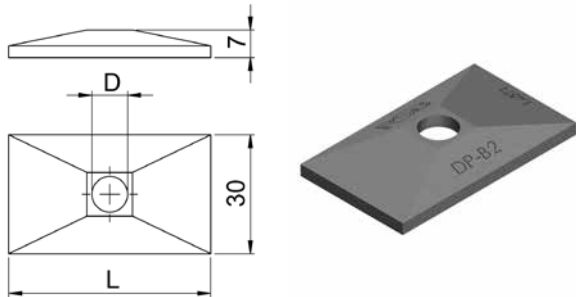

RS DPB-E1

Type-S	Mat.-Nr.	L	D	kg/100
RS DPB-E1-1	956.5130.100	34.0	7.0	2.300
RS DPB-E1-2	956.5130.200	51.0	9.0	3.400
RS DPB-E1-3	956.5130.300	64.0	9.0	4.400
RS DPB-E1-4	956.5130.400	78.0	9.0	5.300
RS DPB-E1-5	956.5130.500	102.0	9.0	7.200

Lieferung nur in Einheitspackungen = Beutel à 25 Stk.

Delivery in packing units only = bags with 25 pcs.

Suministro únicamente en paquetes unitarios = bolsas de 25 pzs.

Sechskantschraube

Stahl verzinkt, Serie A

Hexagon screw

zinc-plated steel, series A

Tornillo hexagonal

acero galvanizado, serie A

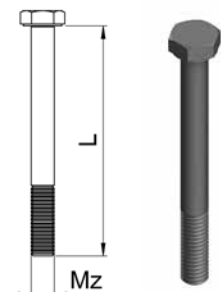

RS SSA-VZ

Type-S	Mat.-Nr.	Mz	L	kg/100
RS SSA-VZ-0/1	946.4210.000	M6	30.0	0.800
RS SSA-VZ-2	946.4210.200	M6	35.0	0.900
RS SSA-VZ-3	946.4210.300	M6	40.0	1.000
RS SSA-VZ-4	946.4210.400	M6	45.0	1.200
RS SSA-VZ-5	946.4210.500	M6	60.0	1.400
RS SSA-VZ-6	946.4210.600	M6	70.0	1.800
RS SSA-VZ-7	946.4210.700	M6	100.0	1.900

Lieferung nur in Einheitspackungen:
Größen 0 bis 6 = Beutel à 50 Stk.
Größe 7 = Beutel à 20 Stk.

Delivery in packing units only:
Sizes 0 to 6 = Bags with 50 pcs.
Size 7 = Bags with 20 pcs.

Suministro únicamente en paquetes unitarios:
Tamaños 0 a 6 = Bolsas de 50 pzs.
Tamaño 7 = Bolsas de 20 pzs.

Sechskantschraube

Edelstahl 1.4571/1.4401, Serie A

Hexagon screw

stainless steel 1.4571/1.4401, series A

Tornillo hexagonal

acero inoxidable 1.4571/1.4401, serie A

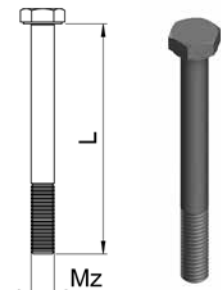

RS SSA-E1

Type-S	Mat.-Nr.	Mz	L	kg/100
RS SSA-E1-0/1	946.5210.000	M6	30.0	0.800
RS SSA-E1-2	946.5210.200	M6	35.0	0.900
RS SSA-E1-3	946.5210.300	M6	40.0	1.000
RS SSA-E1-4	946.5210.400	M6	45.0	1.200
RS SSA-E1-5	946.5210.500	M6	60.0	1.500
RS SSA-E1-6	946.5210.600	M6	70.0	1.800
RS SSA-E1-7	946.5210.700	M6	100.0	2.000

Lieferung nur in Einheitspackungen:
Größen 0 bis 6 = Beutel à 50 Stk.
Größe 7 = Beutel à 20 Stk.

Delivery in packing units only:
Sizes 0 to 6 = Bags with 50 pcs.
Size 7 = Bags with 20 pcs.

Suministro únicamente en paquetes unitarios:
Tamaños 0 a 6 = Bolsas de 50 pzs.
Tamaño 7 = Bolsas de 20 pzs.

Innensechskantschraube

Stahl verzinkt, Serie A

Hexagon socket screw

zinc-plated steel, series A

Tornillo hexágono interior

acero galvanizado, serie A

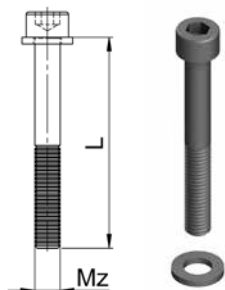

RS ISA-VZ

Type-S	Mat.-Nr.	Mz	L	kg/100
RS ISA-VZ-0/1	946.4220.000	M6	20.0	0.600
RS ISA-VZ-2	946.4220.200	M6	25.0	0.700
RS ISA-VZ-3	946.4220.300	M6	30.0	0.800
RS ISA-VZ-4	946.4220.400	M6	35.0	1.000
RS ISA-VZ-5	946.4220.500	M6	50.0	1.200
RS ISA-VZ-6	946.4220.600	M6	60.0	1.400
RS ISA-VZ-7	946.4220.700	M6	90.0	1.800

Lieferung nur in Einheitspackungen:
Größen 0 bis 6 = Beutel à 50 Stk.
Grösse 7 = Beutel à 20 Stk.

Delivery in packing units only:
Sizes 0 to 6 = Bags with 50 pcs.
Size 7 = Bags with 20 pcs.

Suministro únicamente en paquetes unitarios:
Tamaños 0 a 6 = Bolsas de 50 pzs.
Tamaño 7 = Bolsas de 20 pzs.

Innensechskantschraube

Edelstahl 1.4571/1.4401, Serie A

Hexagon socket screw

stainless steel 1.4571/1.4401, series A

Tornillo hexágono interior

acero inoxidable 1.4571/1.4401, serie A

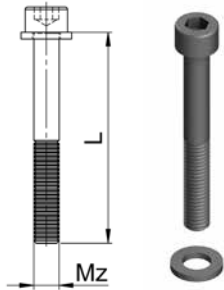

RS ISA-E1

Type-S	Mat.-Nr.	Mz	L	kg/100
RS ISA-E1-0/1	946.5220.000	M6	20.0	0.600
RS ISA-E1-2	946.5220.200	M6	25.0	0.700
RS ISA-E1-3	946.5220.300	M6	30.0	0.800
RS ISA-E1-4	946.5220.400	M6	35.0	1.000
RS ISA-E1-5	946.5220.500	M6	50.0	1.200
RS ISA-E1-6	946.5220.600	M6	60.0	1.400
RS ISA-E1-7	946.5220.700	M6	90.0	1.800

Lieferung nur in Einheitspackungen:
Größen 0 bis 6 = Beutel à 50 Stk.
Größe 7 = Beutel à 20 Stk.

Delivery in packing units only:
Sizes 0 to 6 = Bags with 50 pcs.
Size 7 = Bags with 20 pcs.

Suministro únicamente en paquetes unitarios:
Tamaños 0 a 6 = Bolsas de 50 pzs.
Tamaño 7 = Bolsas de 20 pzs.

Aufbauschraube

Edelstahl 1.4571/14401, Serie A

Stacking screw

stainless steel 1.4571/14401, serie A

Tornillo de apilamiento

acero inoxidable 1.4571/1.4401, serie A

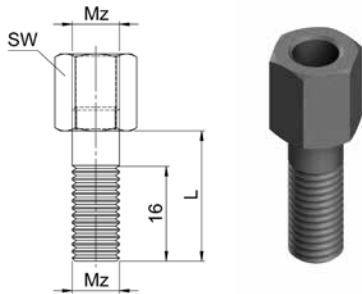

RS ASA-E1

Type-S	Mat.-Nr.	Mz	SW	L	kg/100
RS ASA-E1-0/1	946.5240.000	M6	11	20.0	1.400
RS ASA-E1-2	946.5240.200	M6	11	25.0	1.400
RS ASA-E1-3	946.5240.300	M6	11	28.0	1.700
RS ASA-E1-4	946.5240.400	M6	11	34.0	1.800
RS ASA-E1-5	946.5240.500	M6	11	50.0	2.000

Lieferung nur in Einheitspackungen = Beutel à 25 Stk.

Delivery in packing units only = bags with 25 pcs.

Suministro únicamente en paquetes unitarios = bolsas de 25 pzs.

Tragschiene

Stahl blank, Serie A

Mounting rail

steel, series A

Riel de soporte

acero, serie A

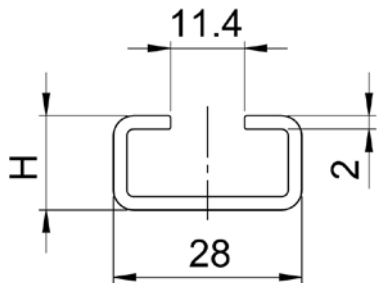

RSTS-SB

Type	Mat.-Nr.	L	H	kg/m
RS TS11A-SB-1m	946.4140.111	1000.0	11.0	0.866

Tragschiene

Edelstahl 1.4571/1.4401, Serie A

Mounting rail

stainless steel 1.4571/1.4401, series A

Riel de soporte

acero inoxidable 1.4571/1.4401, serie A

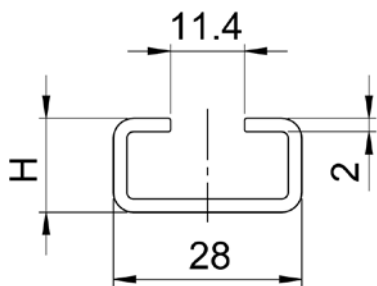

RSTS-E1

Type	Mat.-Nr.	L	H	kg/m
RS TS11A-E1-1m	946.5140.111	1000.0	11.0	0.862

Tragschienenmutter

Stahl verzinkt, Serie A

Rail nut

zinc-plated steel, series A

Tuerca de riel de soporte

acero galvanizado, serie A

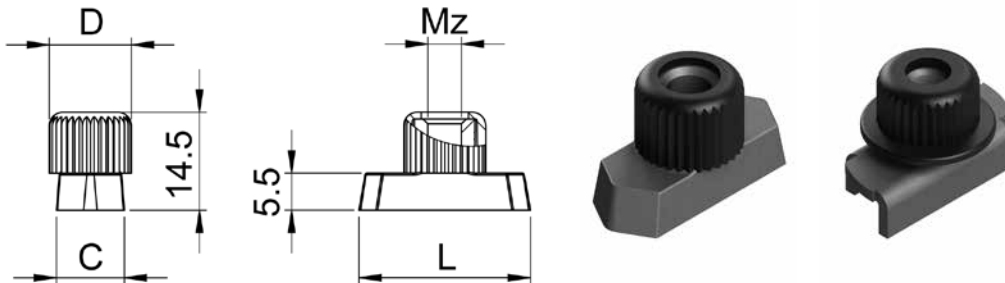

RS TMA-VZ/TMVA-VZ

Type	Mat.-Nr.	L	C	D	Mz	kg/100
RS TMA-VZ	946.4160.000	25.4	10.4	12.0	M6	1.200
RS TMVA-VZ	946.4170.000	24.9	10.5	12.0	M6	0.700

Typ TMVA mit Verlustsicherung.

Der grosse Flansch der Gummikappe verhindert, dass die Tragschienenmutter während der Montage in die Schiene fällt, und hat zusätzlich eine schall- und vibrationsdämmende Funktion. Dadurch ist das System schnell und einfach zu montieren und zu justieren, auch bei vertikaler Installation.

Lieferung nur in Einheitspackungen à 50 Stk.

Type TMVA with loss protection.

The large flange of the rubber cap prevents the rail nut from falling into the rail during installation and acts also to absorb impacts and vibrations. This makes the system quick and easy to install and adjust, even in a vertical installation.

Delivery in packing units of 50 pcs. only

Tipo TMVA con protección contra pérdida.

La gran brida en la tapa de goma previene que la tuerca caiga en el riel durante la instalación y absorbe también impactos y vibraciones. Esto hace que el sistema sea rápido y fácil de instalar y ajustar, incluso en una instalación vertical.

Suministro únicamente en paquetes unitarios de 50 pzs.

Tragschienenmutter

Edelstahl 1.4571/1.4401, Serie A

Rail nut

stainless steel 1.4571/1.4401, series A

Tuerca de riel de soporte

acero inoxidable 1.4571/1.4401, serie A

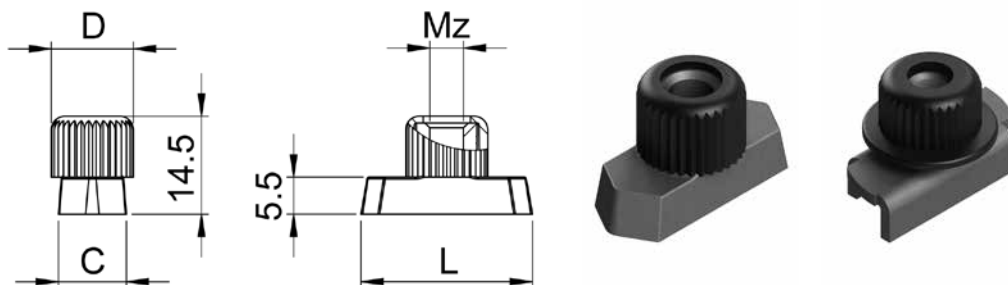

RS TMA-E1 / TMVA-E1

Type	Mat.-Nr.	L	C	D	Mz	kg/100
RS TMA-E1	946.5160.000	25.4	10.4	12.0	M6	1.508
RS TMVA-E1	946.5170.000	24.9	10.5	12.0	M6	0.940

Typ TMVA mit Verlusicherung.

Der grosse Flansch der Gummikappe verhindert, dass die Tragschienenmutter während der Montage in die Schiene fällt, und hat zusätzlich eine schall- und vibrationsdämmende Funktion. Dadurch ist das System schnell und einfach zu montieren und zu justieren, auch bei vertikaler Installation.

Lieferung nur in Einheitspackungen à 50 Stk.

Type TMVA with loss protection.

The large flange of the rubber cap prevents the rail nut from falling into the rail during installation and acts also to absorb impacts and vibrations. This makes the system quick and easy to install and adjust, even in a vertical installation.

Delivery in packing units of 50 pcs. only

Tipo TMVA con protección contra pérdida.

La gran brida en la tapa de goma previene que la tuerca caiga en el riel durante la instalación y absorbe también impactos y vibraciones. Esto hace que el sistema sea rápido y fácil de instalar y ajustar, incluso en una instalación vertical.

Suministro únicamente en paquetes unitarios de 50 pzs.

**Montage-
möglichkeiten**

Installation Options

Opciones de montaje

1. Montage auf Anschweißplatten

Die Anschweißplatten auf einer mit der Belastung abgestimmten Unterlage anschweißen. Hierbei ist auf die Ausrichtung der Schelle zu achten.

Die untere Schellenhälfte auf die Anschweißplatte klemmen, das Rohr einlegen, die zweite Schellenhälfte aufsetzen und mit den Schrauben festziehen. Auf die Vorspannung achten; Schellenhälften dürfen sich nach der Montage nicht berühren.

Nicht mit aufgesetzter Kunststoff-Schelle schweißen!

2. Montage auf Tragschienen

Die Tragschienen werden in Stücken zu 1 m geliefert; andere Längen auf Anfrage. Die Tragschiene anschweißen, Tragschienenmutter in die Schiene einführen und bis zum Anschlag drehen.

Die untere Schellenhälfte auf die Tragschienenmutter aufkleben, das Rohr einlegen, die zweite Schellenhälfte aufsetzen und mit den Schrauben festziehen. Vor dem Festziehen der Schrauben ist eine Positionierung der Schelle möglich. Auf die Vorspannung achten; Schellenhälften dürfen sich nach der Montage nicht berühren.

1. Installation on weld-on plates

Weld the weld-on plates to a base suitable for the load. Here it is important to make sure the clamp is properly aligned.

Fasten the lower half of the clamp to the weld-on plate, insert the tube, set the second half of the clamp in place, and use screws to tighten the clamp. Pay attention to the pretension; clamp halves should not be touching after installation.

Do not weld with plastic clamps in place!

2. Installation on mounting rails

The mounting rails are delivered in pieces of 1 m in length, other lengths available on request.

Weld the mounting rail, place the rail nuts in the rail and turn until they stop. Fasten the lower half of the clamp to the rail nuts, insert the tube, set the second half of the clamp in place, and use screws to tighten the clamp. The clamp can be positioned before the screws are tightened. Pay attention to the pretension; clamp halves should not be touching after installation.

1. Montaje sobre chapas de soldadura

Soldar las chapas de soldadura sobre una base adecuada para la carga prevista. Vigilar la orientación de la abrazadera.

Apretar la mitad inferior de la abrazadera sobre la chapa de soldadura, pasar el tubo, colocar la segunda mitad de la abrazadera y apretar con los tornillos. Vigilar la tensión inicial (las dos mitades de la abrazadera no deben tocarse una vez finalizado el montaje).

¡No soldar con la abrazadera de plástico colocada!

2. Montaje sobre rieles de soporte

Los rieles de soporte se suministran en piezas de 1 m (otros largos a petición). Soldar el riel de soporte o atornillarlo con un ángulo de fijación. Introducir las tuercas de riel de soporte en el riel y girar hasta el tope.

Apretar la mitad inferior de la abrazadera sobre las tuercas de riel de soporte, pasar el tubo, colocar la segunda mitad de la abrazadera y apretar con los tornillos. Antes de apretar los tornillos es posible posicionar la abrazadera. Vigilar la tensión inicial (las dos mitades de la abrazadera no deben tocarse una vez finalizado el montaje).

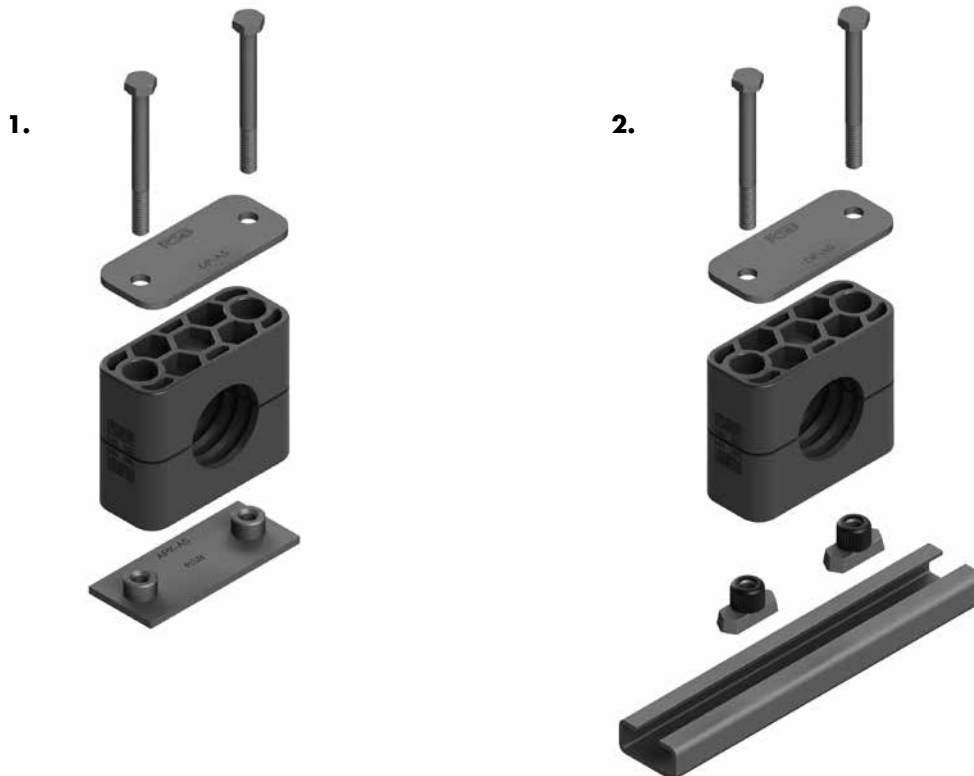

Hinweis: Beim Einsatz von Innensechskantschrauben werden keine Deckplatten verwendet. Die Innensechskantschrauben liegen in der Schellenhälfte versenkt.

Note: When using hexagon socket screws no cover plates are used. The hexagon socket screws are countersunk in the clamp body.

Nota: Si se usan tornillos de hexágono interior no se utilizan placas de cobertura. Los tornillos de hexágono interior quedan encastrados en el cuerpo de la abrazadera.

Rohrschellen

Tube clamps

Abrazaderas de tubo

**Montage-
möglichkeiten**

Installation Options

Opciones de montaje

Empfohlener Schellenabstand

Recommended clamp spacing

Separación recomendada entre las mitades de la abrazadera

Rohraußendurchmesser / External diameter of tube / Diámetro exterior del tubo (mm)	Schellenabstand / Clamp spacing / Separación de abrazadera A (m)
6.0 - 12.7	1.0
12.7 - 22.0	1.2
22.0 - 32.0	1.5
32.0 - 38.0	2.0
38.0 - 57.0	2.7
57.0 - 75.0	3.0
75.0 - 76.1	3.5

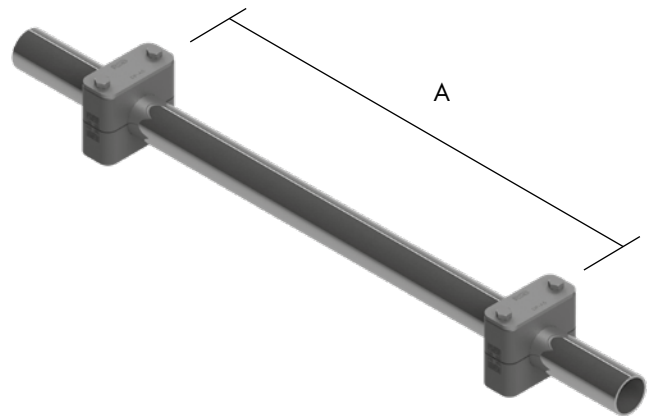

Rohrbogenmontage

Rohrbögen sind unmittelbar vor und hinter dem Bogen mit Rohrschellen zu befestigen.

Tube elbow installation

Tube elbows should be fastened with tube clamps directly before and after the bend.

Montaje en tubos acodados

Los tubos acodados se deben fijar con abrazaderas de tubo a los dos lados del codo.

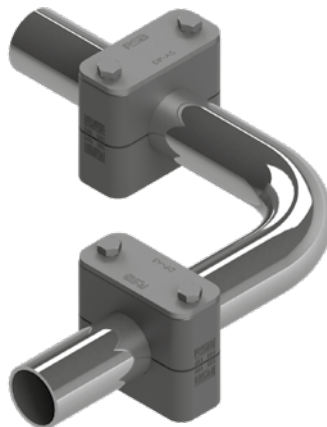

Technische Informationen Technical information Información técnica

Schraubenanzugsdrehmomente und axiale Rohrhaltekräfte

Die angegebenen Schraubenanzugsdrehmomente und axialen Rohrhaltekräfte beziehen sich auf die jeweilige Montageart. Die axiale Rohrhaltekraft (gemäß DIN 3015 Teil 10) ist ein Mittelwert, ermittelt aus drei Versuchen bei +23 °C mit einem Stahlrohr nach DIN 2448 aus St 37, bei dem Haftreibung vorausgesetzt wird. Bei Belastung der Schelle in axialer Rohrrichtung mit der angegebenen Prüfkraft (F) gleitet das Rohr in der Schelle nicht.

Screw tightening torques and axial tube holding power

The specified screw tightening torques and axial tube holding power are based on installation as mentioned. The axial tube holding power (pursuant to DIN 3015, Part 10) is a mean value, determined from three tests at +23 °C with a steel tube according to DIN 2448 made of St 37, where static friction is provided. The tube will not slide in the clamp when force is applied to the clamp in the axial tube direction at the specified test load (F).

Par de apriete de los tornillos y fuerzas axiales de retención de tubo

Los pares de apriete indicados para los tornillos y las fuerzas axiales de retención de tubo según el tipo de montaje. La fuerza axial de retención de tubo (según DIN 3015, parte 10) es un valor medio determinado a partir de tres ensayos a +23 °C con un tubo de acero St 37 conforme a DIN 2448 en los que se presume adherencia. Al aplicar una carga sobre la abrazadera RSB en dirección al eje del tubo con la fuerza de ensayo indicada (F), el tubo no se desliza dentro de la abrazadera.

1. Montage mit Sechskantschrauben und Deckplatten nach ISO 4014/4017 (DIN 931/933)

1. Installation with hexagon screws and cover plates according to ISO 4014/4017 (DIN 931/933)

1. Montaje con tornillos hexagonal y placas de cobertura según ISO 4014/4017 (DIN 931/933)

Befestigungsschraube für alle Typen M6

Retaining screw for all types M6

Tornillo de fijación para todos los tipos M6

Größe Size Dim.	PP		PA		Aluminium / Aluminio	
	Anzugsdrehmoment Tightening torque Par de apriete (Nm)	Rohrhaltekraft Tube holding power Fuerza de retención de tubo F (kN)	Anzugsdrehmoment Tightening torque Par de apriete (Nm)	Rohrhaltekraft Tube holding power Fuerza de retención de tubo F (kN)	Anzugsdrehmoment Tightening torque Par de apriete (Nm)	Rohrhaltekraft Tube holding power Fuerza de retención de tubo F (kN)
0	8	0.6	10	0.6	12	3.5
1	8	1.1	10	0.7	12	4.2
2	8	1.2	10	0.8	12	4.3
3	8	1.4	10	1.6	12	4.8
4	8	1.5	10	1.7	12	5.0
5	8	1.9	10	2.0	12	7.3
6	8	2.0	10	2.5	12	8.9
7	8	2.3	10	3.2		

2. Montage mit Innensechskantschrauben und ohne Deckplatten nach ISO 4762

2. Installation with hexagon socket screws and without cover plates according to ISO 4762

2. Montaje con tornillos hexágonos interior y sin placas de cobertura según ISO 4762

Befestigungsschraube für alle Typen M6

Retaining screw for all types M6

llo de fijación para todos los tipos M6









Größe Size Dim.	PP		PA		Aluminium / Aluminio	
	Anzugsdrehmoment Tightening torque Par de apriete (Nm)	Rohrhaltekraft Tube holding power Fuerza de retención de tubo F (kN)	Anzugsdrehmoment Tightening torque Par de apriete (Nm)	Rohrhaltekraft Tube holding power Fuerza de retención de tubo F (kN)	Anzugsdrehmoment Tightening torque Par de apriete (Nm)	Rohrhaltekraft Tube holding power Fuerza de retención de tubo F (kN)
0			auf Anfrage / on request / bajo petición			
1	2.0	0.45	2.5	0.55	12	4.2
2	2.0	0.85	2.5	0.95	12	4.3
3	2.0	0.60	2.5	0.65	12	4.8
4	2.5	0.85	3.5	1.05	12	5.0
5	2.5	1.30	3.5	1.40	12	7.3
6	2.5	1.05	3.5	1.15	12	8.9
7			auf Anfrage / on request / bajo petición			









**Zubehör und
Werkzeuge**

**Accessories and
tools**

**Accesorios y
utillajes**



	Seite/Page/Página
Rohrkompensierverbindung Tube compensator Compensador de tubos	90.5  RK 51900
Winkelspange Bend clip Guía acodada para tubo	90.6-90.9  AC 832
Schlauchklemme PE Hose clamp PE Abrazadera de manguera PE	90.10  AC SPE
Schlauch-Cutty Hose-Cutty Cortador de mangueras	90.11  AC 835
Ersatzmesser für Schlauch-Cutty Spare blade for hose-cutty Cuchilla de recambio para el cortador de mangueras	90.11  AC 836
Schlauch-Schere Hose scissors Tijeras cortamangueras	90.12  AC 1163
Ersatzmesser für AC 1163 Spare blade for AC 1163 Cuchilla de recambio para AC 1163	90.12  AC 1164
Kalibrierwerkzeug SERTOflex Calibration tool SERTOflex Herramienta de calibrage SERTOflex	90.13  AC 86600

	Seite/Page/Página
Lecksuch-Spray Leak detection spray Aerosol detector de fugas	90.14  AC DLS
Gewindedichtungsband aus PTFE Thread seal tape of PTFE Cinta selladora de roscas de PTFE	90.15  AC 840, AC 841
Spezial-Schmieröl Special lubrication oil Aceite lubricante especial	90.15  AC 850
Schmierstoff OX Lubricant OX Lubricante OX	90.16  AC 851 OX
PTFE-Spray PTFE Spray Aerosol de PTFE	90.16  AC DTS
Fettpaste Grease Grasa lubricante	90.17  ASW
Hand-Vormontagestutzen Pre-assembly studs Accesorio de premontaje manual	90.18  HVMS
Vormontagegerät Pre-assembly machine Máquina premontaje	90.19-90.20  US-FL/01

Rohrkompensierverbindung

Tube compensator

Compensador de tubos

RK 51900

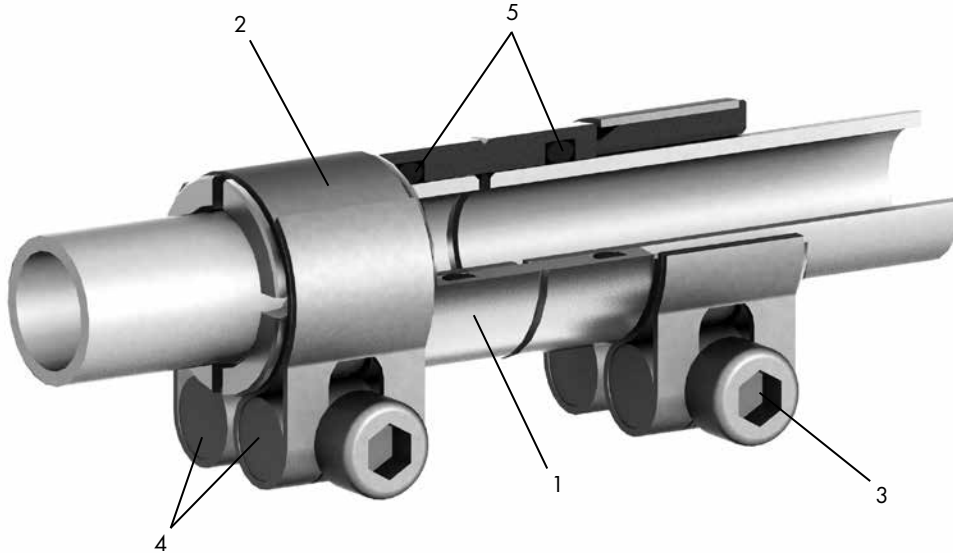

Nr. No.	Bezeichnung Description Descripción	Material Material Material	Nr. No.	Bezeichnung Description Descripción	Material Material Material	Nr. No.	Bezeichnung Description Descripción	Material Material Material
1	Schiebekörper Body Cuerpo	Inox 1.4305	3	Innensechskantschraube Hexagon socket screw Tornillo allen	Inox 1.4301	5*	Dichtung Seal Junta	FKM
2	Gelenkbolzenschelle Hinge bolt clamp Abrazadera de apriete	Inox 1.4301	4	Querbolzen Cross bolt Perno transversal	Messing CV Brass CV Latón CV			

Spezifikationen

Betriebsdruck (PN): 5 bis 40 bar
 Temperatur: -20°C bis +200°C
 Sicherheitsfaktor: 3-fach

Merkmale

Mit der Rohrkompensierverbindung können zwei Rohre einfach miteinander verbunden werden.

* Optionen erhältlich

Dichtung: NBR, NBR LT, VMQ

Specifications

Working pressure (PN): 5 to 40 bar
 Temperature: -20°C to +200°
 Safety factor: 3 times

Characteristics

With the tube compensator, two tubes can be interconnected in a simple way.

* Options available

Seal: NBR, NBR LT, VMQ

Especificaciones

Presión de régimen de trabajo (PN): 5 a 40 bar
 Temperatura: -20°C a +200°C
 Factor de seguridad: 3 veces

Características

Con el compensador de tubos se pueden conectar entre sí dos tubos de manera sencilla.

* Opciones disponibles

Junta: NBR, NBR LT, VMQ

Betriebsdruck

Working pressure

Presión de servicio

Der Versuchsaufbau zur Bestimmung der min. Nenndruckwerte bestand aus zwei mit einer Rohrkompenzierverbindung RK 51900 verbundenen und seitlich nicht fixierten Rohrabschnitten. Daraus resultieren die angegebenen Werte mit Berücksichtigung der 3-fachen Sicherheit.

The test setup for the determination of the min. working pressure values consisted of two tube sections, not fastened at the sides, connected to a tube compensator RK 51900. The values stated are the result of this test and in consideration of a safety factor of 3.

El dispositivo experimental para la determinación de los valores mínimos de la presión nominal se componía de dos secciones tubulares unidas entre sí con un conector de compensación de tubos RK 51900 y no fijadas lateralmente. A partir de aquí se obtienen los valores indicados teniendo en cuenta la triple seguridad.



Versuchsaufbau / test setup / dispositivo experimental

In der Praxis sind in einem geschlossenen Rohrsystem die Rohrabschnitte immer durch Rohrschellen, Wanddurchführungen, Bögen in der Leitung oder andere Befestigungen fixiert, was ein Ausgleiten aus der Rohrkompenzierverbindung verhindert.

Typically, the tube sections of a closed system are always fixed by tube clamps, wall ducts, bends in the tube or other fastenings, which prevent the sliding of the tube out of the compensator.

En la práctica, en un sistema tubular cerrado, las secciones tubulares siempre están fijadas mediante abrazaderas, pasamuros, codos en el conducto u otros sistemas de sujeción, lo cual impide el deslizamiento hacia el exterior del conector de compensación de tubos.

Abhängig von Anzahl, Qualität und Materialauswahl der Sicherungselemente sind deutlich höhere Betriebsdrücke als die hier angegebenen möglich. Werden die in der Praxis empfohlenen Masse für freie Rohrabschnitte eingehalten, sind Drücke von 10 bar (Personenverkehr) bis 16 bar (Güterverkehr) problemlos erreichbar.

Depending on the number, quality and material of the securing elements, significantly higher operating pressures than those specified are possible. If the usually recommended measures for not-fixed tube sections are followed, pressures from 10 bar (passenger transportation) up to 16 bar (freight transportation) can easily be reached.

Dependiendo del número, la calidad y el material elegido para los elementos de sujeción, son posibles valores de presión de servicio considerablemente superiores a los aquí indicados. Si en la práctica se respetan las masas recomendadas para las secciones tubulares, se pueden alcanzar sin problemas presiones de 10 bar (tráfico de personas) hasta 16 bar (tráfico de mercancías).

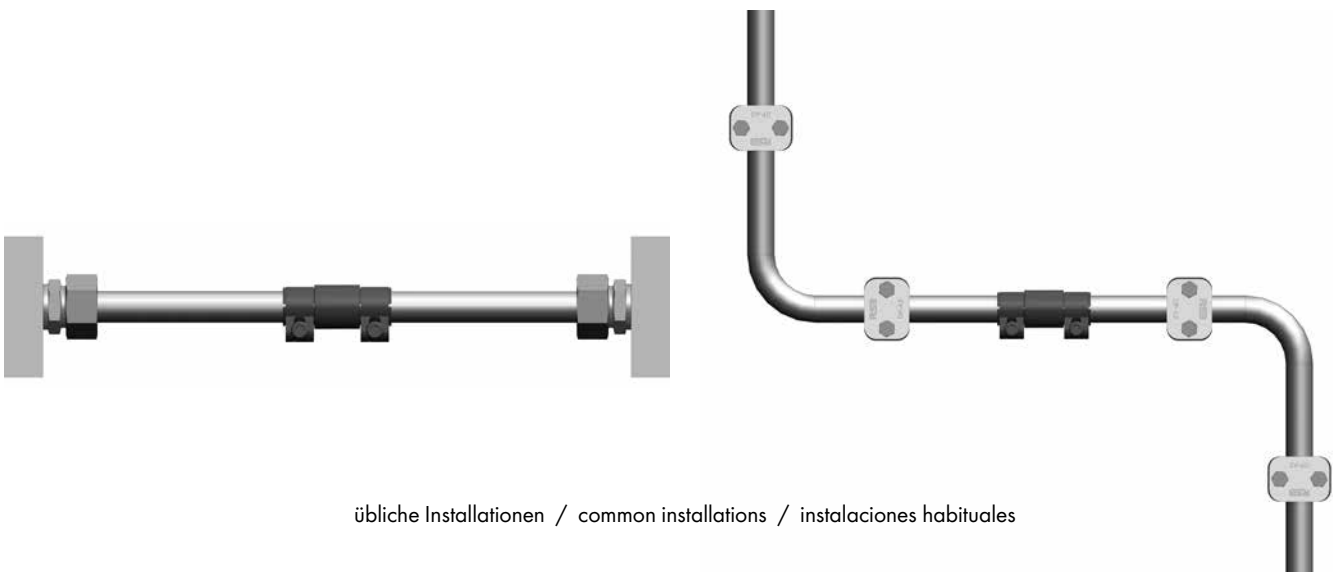

übliche Installationen / common installations / instalaciones habituales

Rohrkompensierverbindung

Tube compensator

Compensador de tubos

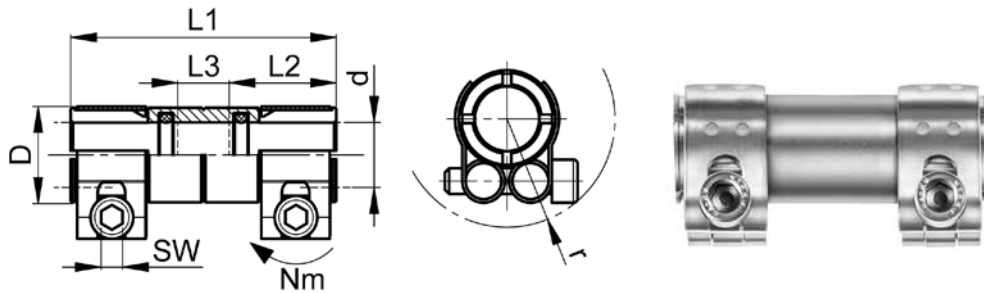

RK 51900

Type-d	Mat.-Nr.	bar	SW	L1	L2	L3	D	Nm	r	kg/100
RK 51900-10	208.1000.100	40	3	48.0	10.2	8.0	18.0	3	17	5.200
RK 51900-15	208.1000.150	30	5	62.0	26.0	10.0	24.0	8	26	14.200
RK 51900-18	208.1000.180	20	5	62.0	26.0	10.0	25.0	8	26	11.000
RK 51900-22	208.1000.220	15	5	64.0	27.0	10.0	30.0	8	28	15.400
RK 51900-28	208.1000.280	5	5	64.0	27.0	10.0	38.0	12	32	23.600

L2 = min. Einstecktiefe
 L3 = max. Rohrabstand
 Nm = Anzugsdrehmoment

L2 = min. insertion depth
 L3 = max. tube distance
 Nm = tightening torque

L2 = profundidad de inserción mínima
 L3 = distancia de tubo máxima
 Nm = par de apriete

Winkelspange PA 90°

Bend clip PA 90°

Guía acodada para tubo PA 90°

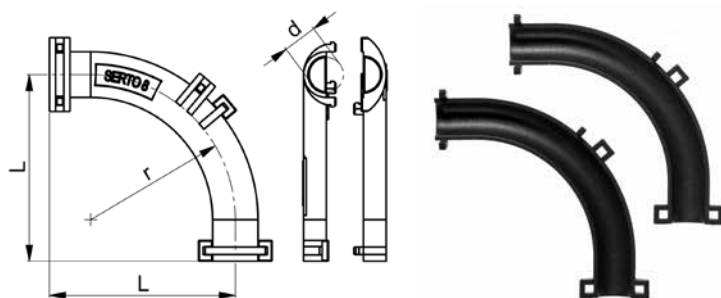

AC 832 90°

Type -d	Mat.-Nr.	L	r	g/Stk
AC 832-6 90°	988.8325.060	40.0	30	4
AC 832-6 90° BU	988.8325.060.BU	40.0	30	4
AC 832-8 90°	988.8325.080	45.5	35	5
AC 832-8 90° BU	988.8325.080.BU	45.5	35	5
AC 832-10 90°	988.8325.100	54.0	40	14
AC 832-10 90° BU	988.8325.100.BU	54.0	40	14
AC 832-12 90°	988.8325.120	65.0	50	19
AC 832-12 90° BU	988.8325.120.BU	65.0	50	19

Führung und Schutz für eng abgebogene Kunststoffrohre.
Geeignet für PA, PU, LDPE, PTFE, FEP-Rohre; nicht geeignet für PVDF-Rohre.

Material
PA66 GF25, Brandverhalten gem. UL 94 V0

Einsatztemperatur
-40°C bis +130°C

Liefereinheit (VPE)
Pack à 20 Stk. lose Halbschalen
BU = Pack à 500 Stk. lose Halbschalen

Location and protection for tightly curved plastic tubes.
Suitable for PA, PU, LDPE, PTFE, FEP tubes; not suitable for PVDF tubes.

Material
PA66 GF25, flammability acc. to UL 94 V0

Operation temperature
-40°C to +130°C

Packaging unit (VPE)
Pack of 20 pcs loose half shells
BU = pack of 500 pcs loose half shells

Guía y protección para tubos de plástico con curvatura cerrada.
Adecuado para tuberías de PA, PU, LDPE, PTFE, FEP; no adecuado para tuberías de PVDF.

Material
PA66 GF25, inflamabilidad según UL 94 V0

Temperatura de empleo
-40°C a +130°C

Unidad de suministro
Bolsa de 20 pz. medias cáscaras sueltas
BU = bolsa de 500 pz. medias cáscaras sueltas

Winkelspange PA 90° montiert
Bend clip PA 90° assembled
Guía acodada para tubo PA 90° ensamblado

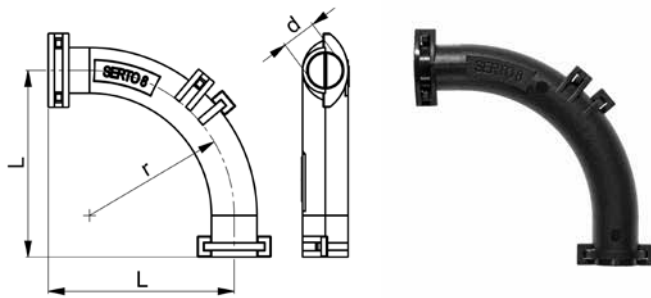

AC 832 90° M

Type -d	Mat.-Nr.	L	r	g/Stk
AC 832-6 90° M	988.8370.060	40.0	30	4
AC 832-6 90° M BU	988.8370.060.BU	40.0	30	4
AC 832-8 90° M	988.8370.080	45.5	35	5
AC 832-8 90° M BU	988.8370.080.BU	45.5	35	5
AC 832-10 90° M	988.8370.100	54.0	40	14
AC 832-10 90° M BU	988.8370.100.BU	54.0	40	14
AC 832-12 90° M	988.8370.120	65.0	50	19
AC 832-12 90° M BU	988.8370.120.BU	65.0	50	19

Führung und Schutz für eng abgebogene Kunststoffrohre.
 Geeignet für PA, PU, LDPE, PTFE, FEP-Rohre; nicht geeignet für PVDF-Rohre.

Material
 PA66 GF25, Brandverhalten gem. UL 94 V0

Einsatztemperatur
 -40°C bis +130°C

Liefereinheit (VPE)
 Pack à 10 Set Winkelspangen montiert
 BU = Pack à 250 Set Winkelspangen montiert

Location and protection for tightly curved plastic tubes.
 Suitable for PA, PU, LDPE, PTFE, FEP tubes; not suitable for PVDF tubes.

Material
 PA66 GF25, flammability acc. to UL 94 V0

Operation temperature
 -40°C to +130°C

Packaging unit (VPE)
 Pack of 10 sets bend clips assembled
 BU = pack of 250 sets bend clips assembled

Guía y protección para tubos de plástico con curvatura cerrada.
 Adecuado para tuberías de PA, PU, LDPE, PTFE, FEP; no adecuado para tuberías de PVDF.

Material
 PA66 GF25, inflamabilidad según UL 94 V0

Temperatura de empleo
 -40°C a +130°C

Unidad de suministro
 Juego de 10 guías acodadas ensambl.
 BU = juego de 250 guías acodadas ensambl.

Winkelspange PA 45°

Bend clip PA 45°

Guía acodada para tubo PA 45°

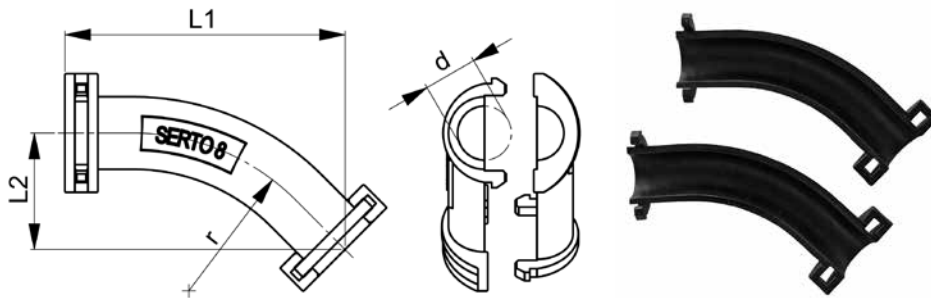

AC 832 45°

Type -d	Mat.-Nr.	L1	L2	r	g/Stk
AC 832-8 45°	988.8345.080	42.7	17.7	35	3
AC 832-8 45° BU	988.8345.080.BU	42.7	17.7	35	3
AC 832-12 45°	988.8345.120	58.0	24.0	50	12
AC 832-12 45° BU	988.8345.120.BU	58.0	24.0	50	12

Führung und Schutz für eng abgebogene Kunststoffrohre.
Geeignet für PA, PU, LDPE, PTFE, FEP-Rohre; nicht geeignet für PVDF-Rohre.

Material
PA66 GF25, Brandverhalten gem. UL 94 V0

Einsatztemperatur
-40°C bis +130°C

Liefereinheit (VPE)
Pack à 20 Stk. lose Halbschalen
BU = Pack à 500 Stk. lose Halbschalen

Location and protection for tightly curved plastic tubes.
Suitable for PA, PU, LDPE, PTFE, FEP tubes; not suitable for PVDF tubes.

Material
PA66 GF25, flammability acc. to UL 94 V0

Operation temperature
-40°C to +130°C

Packaging unit (VPE)
Pack of 20 pcs loose half shells
BU = pack of 500 pcs loose half shells

Guía y protección para tubos de plástico con curvatura cerrada.
Adecuado para tuberías de PA, PU, LDPE, PTFE, FEP; no adecuado para tuberías de PVDF.

Material
PA66 GF25, inflamabilidad según UL 94 V0

Temperatura de empleo
-40°C a +130°C

Unidad de suministro
Bolsa de 20 pz. medias cáscaras sueltas
BU = bolsa de 500 pz. medias cáscaras sueltas

Winkelspange PA 45° montiert

Bend clip PA 45° assembled

Guía acodada para tubo PA 45° ensamblado

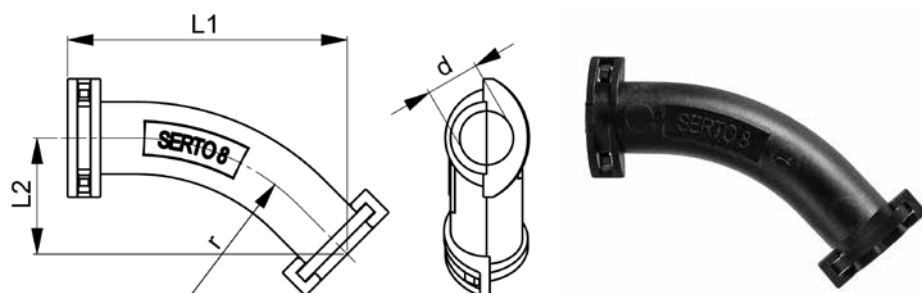

AC 832 45° M

Type -d	Mat.-Nr.	L1	L2	r	g/Stk
AC 832-8 45° M	988.8375.080	42.7	17.7	35	3
AC 832-8 45° M BU	988.8375.080.BU	42.7	17.7	35	3
AC 832-12 45° M	988.8375.120	58.0	24.0	50	12
AC 832-12 45° M BU	988.8375.120.BU	58.0	24.0	50	12

Führung und Schutz für eng abgebogene Kunststoffrohre.
Geeignet für PA, PU, LDPE, PTFE, FEP-Rohre; nicht geeignet für PVDF-Rohre.

Material
PA66 GF25, Brandverhalten gem. UL 94 V0

Einsatztemperatur
-40°C bis +130°C

Liefereinheit (VPE)
Pack à 10 Set Winkelspangen montiert
BU = Pack à 250 Set Winkelspangen montiert

Location and protection for tightly curved plastic tubes.
Suitable for PA, PU, LDPE, PTFE, FEP tubes; not suitable for PVDF tubes.

Material
PA66 GF25, flammability acc. to UL 94 V0

Operation temperature
-40°C to +130°C

Packaging unit (VPE)
Pack of 10 sets bend clips assembled
BU = pack of 250 sets bend clips assembled

Guía y protección para tubos de plástico con curvatura cerrada.
Adecuado para tuberías de PA, PU, LDPE, PTFE, FEP; no adecuado para tuberías de PVDF.

Material
PA66 GF25, inflamabilidad según UL 94 V0

Temperatura de empleo
-40°C a +130°C

Unidad de suministro
Juego de 10 guías acodadas ensambl.
BU = juego de 250 guías acodadas ensambl.

Schlauchklemme PE

Hose clamp PE

Abrazadera de manguera PE

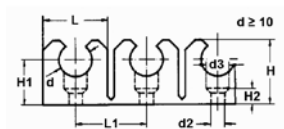
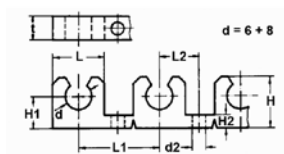

AC SPE

Type -d	Mat.-Nr.	L	L1	L2	H	H1	H2	d2	d3	g/Stk
AC SPE-6	YBD.SPE.0001	12.0	21.0	10.0	14.0	10.0	4.0	4.00	0.00	21
AC SPE-8	YBD.SPE.0002	16.0	25.0	12.0	16.0	10.0	4.0	4.00	0.00	28
AC SPE-10	YBD.SPE.0003	20.0	22.0	0.0	20.0	14.0	5.0	4.00	7.00	39
AC SPE-12	YBD.SPE.0004	24.0	26.0	0.0	21.0	14.0	5.0	4.00	7.00	47
AC SPE-15	YBD.SPE.0005	27.0	29.0	0.0	34.0	26.0	5.0	4.30	8.50	31
AC SPE-18	YBD.SPE.0006	31.0	33.0	0.0	35.5	26.0	5.0	4.30	8.50	37
AC SPE-22	YBD.SPE.0007	36.0	38.0	0.0	37.0	26.0	5.0	4.30	8.50	52
AC SPE-28	YBD.SPE.0008	44.0	46.0	0.0	39.0	26.0	5.0	4.30	8.50	63

Die Klemmen für Rohrdurchmesser 6 bis 12 mm sind jeweils in Leisten zu **10 Stück**, die Klemmen für Rohrdurchmesser 15 bis 28 mm in Leisten zu **5 Stück** gefertigt.

Werkstoff: Polyethylen (PE)
Temperaturbereich: -20°C bis +50°C

The clamps for tube diameters 6 to 12 mm are available in **strips of 10** pieces each, the clamps for tube diameters 15 to 28 mm in **strips of 5** pieces each.

Material: polyethylene (PE)
Temperature range: -20°C to +50°C

Las abrazaderas para diámetro de tubo de 6 a 12 mm se fabrican en regletas de **10 unidades**, las abrazaderas para diámetro de tubo de 15 a 28 mm en regletas de **5 unidades**.

Material: polietileno (PE)
Intervalo de temperatura: -20°C a +50°C

Schlauch-Cutty
Hose-Cutty
Cortador de mangueras



AC 835

Type	Mat.-Nr.	g/Stk
AC 835	988.8350.000	23

Praktisches, handliches Werkzeug zum sauberen Ablängen der Kunststoffrohre und -schläuche bis 12 mm Aussen-Ø.

Useful, handy tool for clean cut off of plastic tubes and hoses of up to 12 mm outer diameter.

Práctica herramienta manual para el corte limpio de tubos y mangueras de plástico de hasta 12 mm de Ø exterior.

Ersatzmesser
für Schlauch-Cutty AC 835

Spare blade
for hose-cutty AC 835

Cuchilla de recambio
para el cortador de mangueras AC 835



AC 836

Type	Mat.-Nr.	g/Stk
AC 836	988.8360.000	80

Schlauch-Schere

für Kunststoffrohre und -schläuche bis Ø 22 mm

Hose scissors

for tubes and hoses in plastic up to Ø 22 mm

Tijeras cortamangueras

para tubos y mangueras de plástico hasta Ø 22 mm



AC 1163

Type	Mat.-Nr.	g/Stk
AC 1163	YBD.1163.001	280

Ersatzmesser

für Schlauch-Schere AC 1163

Spare blade

for hose scissors AC 1163

Cuchilla de recambio

para tijeras cortamangueras AC 1163



AC 1164

Type	Mat.-Nr.	g/Stk
AC 1164	YBD.1164.001	6

Kalibrierwerkzeug SERTOflex
Calibration tool SERTOflex
Herramienta de calibrage SERTOflex

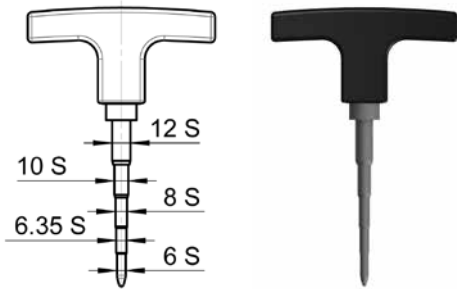

AC 86600

Type -d	Mat.-Nr.	g/Stk
AC 86600	988.8660.000	143

Für Nennweiten 6/6,35/8/10/12 mm

Empfohlen zur Kalibrierung der Rohrenden von SERTOflex, da durch das Ablängen Verformungen entstehen können. Damit wird bei fachgerechter Montage die Dichtheit gewährleistet.

Werkstoff: Inox 1.4305

For nominal widths 6/6,35/8/10/12 mm

Recommended for calibration of the SERTOflex pipe ends, as deformations may be caused by cutting them to length. This ensures that there are no leaks if fitting is carried out properly.

Material: Inox 1.4305

Para diámetros nominales 6/6,35/8/10/12 mm

Recomendada para la calibración de los extremos de los tubos de SERTOflex dado que pueden producirse deformaciones durante el corte de los tubos. Estanqueidad garantizada en caso de montaje profesional.

Material: Inox 1.4305

Lecksuch-Spray
Leak detection spray
Aerosol detector de fugas



AC DLS

Type	Mat.-Nr.	g/Stk
AC DLS	YBD.DLS.0001	620

Allgemeine Anwendung für Druckluft, Sauerstoff und weitere Gase. Eignet sich zum schnellen Auffinden von Leckstellen in Druckluft- und Gasleitungen.

FCKW frei
 Doseninhalt: 500 ml

For general use with compressed air, oxygen and other gases. Suitable for fast leak detection in compressed air and gas lines.

CFC-free
 Contents: 500 ml

Utilización general para aire a presión, oxígeno y otros gases. Apto para la localización rápida de puntos de fuga en tuberías de aire a presión y gas.

Libre de CFC
 Contenido del bote: 500 ml

Gewindedichtungsband aus PTFE
Thread seal tape of PTFE
Cinta selladora de roscas de PTFE



AC 840, AC 841

Type	Mat.-Nr.	g/Stk
AC 840-6 (1/4")	988.8400.060	15
AC 841-9 (3/8")	988.8400.090	17
AC 841-12 (1/2")	988.8400.120	16

Gute chemische Beständigkeit für breite Einsatzmöglichkeiten.

Good chemical resistance for a wide range of applications.

Buena resistencia química para una amplia gama de aplicaciones.

Nicht-härtendes Dichtungsband für sauberes und schnelles Umwickeln der kegeligen Einschraubgewinde. Nicht alternd und immer gebrauchsfertig, das beliebte Mittel für eine dauerhafte Abdichtung.

Flexible seal tape for rapid and clean winding on the tapered adaptor thread. No aging and always ready for use, the popular material for a durable sealing.

Cinta selladora no endurecible para envolver de forma rápida y limpia las roscas de conexión cónicas. No envejece y está siempre lista para usar; el material preferido para un sellado duradero.

Lieferart: in Rollen à 12 m

Form of supply: in rolls of 12 m

Forma de suministro: en rollos de 12 m

Spezial-Schmieröl
Special lubrication oil
Aceite lubricante especial



AC 850

Type	Mat.-Nr.	g/Stk
AC 850	TAC.850.0000	244

Für die Montage von Verschraubungen, besonders aus Edelstahl.

Especially for installing tube unions made of stainless steel.

Para montar racores, especialmente de acero inoxidable.

Lieferart: in Flaschen à 250 ml

Form of supply: in bottles of 250 ml

Forma de suministro: en botellas de 250 ml

Schmierstoff OX
Lubricant OX
Lubricante OX



AC 851 OX

Type	Mat.-Nr.	g/Stk
AC 851 OX	TAC.850.0001	111

Schmierstoff für den Einsatz mit Sauerstoff (getestet von der BAM).

Lubricant for use in oxygene enriched systems (tested by BAM).

Lubricante para la utilización con oxígeno (testado del BAM).

Lieferart: in Tuben à 100 g

Form of supply: in tubes of 100 g

Forma de suministro: en tubos de 100 g

PTFE-Spray
PTFE Spray
Aerosol de PTFE



AC DTS

Type	Mat.-Nr.	g/Stk
AC DTS	YBD.DTS.0001	356

Ein bewährtes Schmier-, Gleit- und Trennmittel für Industrie und Handwerk. Es ist antiadhäsiv, Schmutz abweisend, hitzebeständig bis +260 °C und beständig gegen Wasser, Öl und aggressive Medien.

A proven lubricant and separating agent for industry and trade. It is anti-adhesive, soil-resistant, heat-resistant to +260 °C, and resistant to water, oil and aggressive media.

Un agente lubricante, deslizante y antiadherente de eficacia probada para la industria y los profesionales. Es antiadherente, repele la suciedad, resistente a temperaturas de hasta +260 °C y resistente al agua, aceite y medios agresivos.

FCKW frei, enthält Dichlormethan
 Doseninhalt: 400 ml

CFC-free, contains dichloromethane
 Contents: 400 ml

Libre de CFC, contiene diclorometano
 Contenido del bote: 400 ml

Fettpaste

für die Montage von Edelstahlverschraubungen

Grease

for the assembly of stainless steel fittings

Grasa lubricante

para el montaje de racores de acero inoxidable



ASW

Type	Mat.-Nr.	g/Stk
ASW120	735.0009.001	148
ASW250	735.0009.002	309

Fettpaste ASW ist besonders geeignet für Montagearbeiten, wenn aus optischen Gründen die Anwendung von metallhaltigen Schmierstoffen unerwünscht ist, nickelhaltige Produkte aus Gesundheitsgründen und kupferhaltige Produkte aus elektrochemischen Gründen nicht eingesetzt werden dürfen.

Fettpaste ASW verhindert Festbrennen, Kaltverschweißen und Stick-slip (Ruckgleiten) auch bei hohen Flächenpressungen und geringen Gleitbewegungen (Kriechgeschwindigkeit). Es erleichtert somit die Montage und Demontage von Verschraubungen, auch nach sehr langer Betriebszeit.

Sie wird speziell bei extremen Bedingungen eingesetzt, wie z. B.

- hohen Temperaturen (bis +1400°C)
- aggressiven Medien
- hohem Druck

Fettpaste ASW ist frei von schwefelhaltigen Zusätzen und Halogenen, beständig gegen Heiß-, Kalt- und Salzwasser, die meisten Säuren und Laugen und haft- und abriebfest.

Technische Daten:

Produkt: Fettpaste ASW
 Konsistenz: NGLI-Klasse 0-1
 Farbe: weiß
 Dichte bei +20°C: 1,42 g/cm³, DIN 51757
 Reibungskoeffizient: 0,19 - SRV-Test
 Druckfestigkeit: 3800 - 4000 N (VKA-Test)
 Wasserbeständigkeit: 1-90°C, DIN 51807
 Temperaturbereich: -40°C - +1400°C
 Druckbelastung: 230 N/mm²

Fettpaste ASW ist unempfindlich gegen die meisten Gase, z. B. Propan, Butan, Erdgas, Helium, Freon und Stickstoff. Fettpaste ASW darf allerdings nicht an Sauerstoffflaschen und Acetylenanlagen verwendet werden.

Fettpaste ASW ist frei von Silikon, Blei und anderen toxischen Schwermetallen. EG-Sicherheitsdatenblätter sind auf Anfrage erhältlich.

ASW Grease is particularly suitable for assembly work, if the use of lubricants containing metal components (for the sake of visual effect), products containing nickel (due to health reasons) and the use of products containing copper (due to electro-chemical reasons) have to be avoided.

ASW Grease prevents solidifying and hardening when affected by heat, welding without pre-heating and stick-slip (jerky sliding), also in the case of high surface pressure and minor sliding movements (crawling speed).

The grease is specifically applied under extreme conditions, e.g.

- at high temperatures (up to +1400°C),
- when aggressive materials are used, and
- under high pressure

ASW Grease is free of halogens and additives containing sulphur, durable in hot and cold water, and also salt water as well as most acids and alkaline solutions and adhesion- and abrasion-proof.

Technical Data:

Product: ASW Grease
 Consistency: NGLI-Class 0-1
 Color: White
 Density at +20°C: 1,42 g/cm³, DIN 51757
 Friction coefficient: 0,19 - SRV-Test
 Pressure resistance: 3800 - 4000 N (VKA-Test)
 Durability in water: 1-90°C, DIN 51807
 Temperatur range: -40°C - +1400°C
 Pressure load: 230 N/mm²

ASW Grease is non-sensitive to most gases, e.g. propane, butane, natural gas, helium, freon and nitrogen. However, ASW Grease should not be applied to oxygen bottles and acetylene equipment.

ASW Grease is free of silicone, lead and other toxic heavy metals. EC safety information is available on request.

La grasa lubricante ASW es especialmente adecuada para trabajos de montaje cuando no se desea utilizar lubricantes a base de metales por razones estéticas, no deben usarse productos a base de níquel por cuestiones de salud y existen factores electroquímicos que impiden el uso de productos a base de cobre.

La grasa lubricante ASW impide la adhesión, la soldadura en frío de las rugosidades y el efecto "stick-slip" (deslizamiento intermitente), incluso con presiones superficiales altas y deslizamientos pequeños (velocidad de fluencia). Por consiguiente, facilita el montaje y también el desmontaje de racores que han estado mucho tiempo en servicio.

Se utiliza sobre todo en condiciones extremas como, p. ej.:

- altas temperaturas (hasta +1400°C)
- medios agresivos
- alta presión

La grasa lubricante ASW no contiene aditivos sulfurados o halógenos, es resistente al agua caliente, fría y salada, a la mayoría de ácidos y bases, adherente y resistente al desgaste.

Datos técnicos:

Producto: grasa lubricante ASW
 Consistencia: clase NGLI 0-1
 Color: blanco
 Densidad a +20°C: 1,42 g/cm³, DIN 51757
 Coeficiente de rozamiento: 0,19; ensayo SRV
 Resistencia a la presión: 3800 - 4000 N (ensayo VKA)
 Resistencia al agua: 1-90°C, DIN 51807
 Intervalo de temperatura: -40°C - +1400°C
 Carga por compresión: 230 N/mm²

La grasa ASW es insensible a la mayoría de los gases como, p. ej., propano, butano, gas natural, helio, freón y nitrógeno. No obstante, la grasa ASW no debe utilizarse en botellas de oxígeno o instalaciones de acetileno.

La grasa lubricante ASW está exenta de silicona, de plomo y otros metales pesados tóxicos. Bajo demanda se suministran hojas de datos de seguridad CE.

Hand-Vormontagegestutzen

für die manuelle Vormontage

Pre-assembly studs

for manual pre-assembly

Accesorio de premontaje manual

para manual pre-ensamblaje

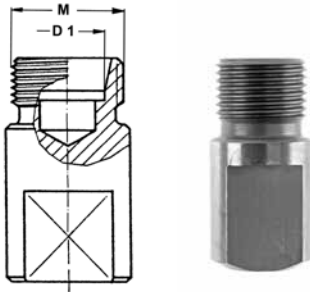

HVMS-..L/S

Type-D1	Mat.-Nr.	D1	M	g/Stk
M=metrisches Gewinde (zylindrisch)	M=metric thread (parallel)		M=rosca métrica (cilindrica)	
HVMS-06L	706.6001.060.20	6.0	12x1.5	60
HVMS-08L	706.6001.080.20	8.0	14x1.5	62
HVMS-10L	706.6001.100.20	10.0	16x1.5	64
HVMS-12L	706.6001.120.20	12.0	18x1.5	67
HVMS-15L	706.6001.150.20	15.0	22x1.5	88
HVMS-18L	706.6001.180.20	18.0	26x1.5	185
HVMS-22L	706.6001.220.20	22.0	30x2.0	194
HVMS-28L	706.6001.280.20	28.0	36x2.0	524
HVMS-35L	706.6001.350.20	35.0	45x2.0	467
HVMS-42L	706.6001.420.20	42.0	52x2.0	499
HVMS-06S	706.6001.060.30	6.0	14x1.5	61
HVMS-08S	706.6001.080.30	8.0	16x1.5	65
HVMS-10S	706.6001.100.30	10.0	18x1.5	69
HVMS-12S	706.6001.120.30	12.0	20x1.5	97
HVMS-14S	706.6001.140.30	14.0	22x1.5	101
HVMS-16S	706.6001.160.30	16.0	24x1.5	101
HVMS-20S	706.6001.200.30	20.0	30x2.0	210
HVMS-25S	706.6001.250.30	25.0	36x2.0	527
HVMS-30S	706.6001.300.30	30.0	42x2.0	510
HVMS-38S	706.6001.380.30	38.0	52x2.0	570

Für die Vormontage im Schraubstock.
Aus gehärtetem Werkzeugstahl.

For pre-assembly in a vice.
Made of hardened tool-steel.

Para el premontaje en el tornillo de banco.
De acero templado para herramientas.

Der Vormontagegestutzen unterliegt dem üblichen Verschleiß und ist daher in regelmäßigen Abständen mit Konuslehren auf Lehrenhaltigkeit zu prüfen. Nicht lehrenhaltige Vormontagegestutzen sind auszutauschen, um eine Fehlmontage zu vermeiden.

The pre-assembly tool is subject to regular wear and tear and should, therefore, be inspected for accuracy to gauge in regular intervals using a cone gauge. Pre-assembly tools that are not accurate to gauge must be replaced to prevent incorrect assembly.

Los racores de premontaje están sometidos a un desgaste normal, por lo que es necesario comprobar periódicamente que cumplan el calibre utilizando calibres de cono. Los racores de premontaje que no cumplan el calibre deben sustituirse para evitar un montaje incorrecto.

Elektrohydraulisches Vormontagegerät
Electro-hydraulic pre-assembly machine
Máquina de premontaje electrohidráulica



US-FL/01

Type	Mat.-Nr.	Spannung / Voltage / Tensión
US-FL/01/230 Volt	888.1000.000.13	230 V / 50 Hz / 1 Ph
US-FL/01/400 Volt	888.1000.000.14	400 V / 50 Hz / 3 Ph

Für die Vormontage von Schneidringverschraubungen von 6 bis 42 mm und Klemmringverschraubungen von 6 bis 25 mm Durchmesser

Der jeweilige Verpressdruck wird vor der Montage manuell eingestellt (empfohlene Werte siehe Kapitel i).

Mit einem zusätzlichen Werkzeug kann diese Maschine auch zum Bördeln von Rohren von 6 bis 42 mm Durchmesser mit einer maximalen Wandstärke von 4 mm eingesetzt werden.

Technische Daten

Maße (LxTxH)	450 x 630 x 270 mm
Gewicht	58 kg
Motorleistung	0,75 kW

Lieferung erfolgt ohne Stecker.

Das Vormontagegerät kann auch in einer manuellen Ausführung angeboten werden.

Für die projektbezogene Montage von Kleinserien oder zum Austesten unter Produktionsbedingungen bietet EXMAR das Vormontagegerät für einen Zeitraum von max. 3 Monaten als Leihgerät an. Kontaktieren Sie uns.

For the pre-assembly of cutting ring fittings from 6 to 42 mm diameter and of clamping ring fittings from 6 to 25 mm diameter

The pressure is set manually before each operation (recommended values see chapter i).

Using an additional tool, this machine can also be used for flaring tubes from 6 to 42 mm diameter with a maximum wall thickness of 4 mm.

Technical data

Dimensions (lxdxh)	450 x 630 x 270 mm
Weight	58 kg
Power	0,75 kW

Delivered without a connector.

A manual version of the pre-assembly device is also available.

For the project-related assembly of small series or for testing under production conditions, EXMAR offers the pre-assembly machine on loan for a maximum period of 3 months. Please contact us.

Para el premontaje de racores de anillo cortante de 6 a 42 mm de diámetro y de racores de anillo de apriete de 6 a 25 mm de diámetro

La presión correspondiente se ajusta manualmente antes del montaje (valores recomendados ver capítulo i).

Con una herramienta suplementaria, la máquina puede utilizarse también para rebordear tubos de 6 a 42 mm diámetro con un grosor de pared máximo de 4 mm.

Datos técnicos

Dimensión (lpxxl)	450 x 630 x 270 mm
Peso	58 kg
Potencia	0,75 kW

El suministro se realiza sin conector.

La máquina de premontaje también se ofrece en versión manual.

Para el montaje de series pequeñas dentro de un proyecto o para comprobaciones en condiciones de producción, EXMAR ofrece la máquina de premontaje durante un tiempo limitado de 3 meses como máximo en concepto de préstamo. Póngase en contacto con nosotros.

Zubehör für elektrohydraulisches Vormontagegerät
Accessories for electro-hydraulic pre-assembly machine
Accesorios para la máquina de premontaje electrohidráulica



US-FL/01-P / US-FL/01-WZ

D1	Gegenhalteplatte Counter plate Placa de sujeción	Mat.-Nr.	Vormontagestutzen Pre-assembly stud Racor de premontaje	Mat.-Nr.
06L	US-FL/01-P06L/S	886.1001.060.21	US-FL/01-WZ06L	886.1002.060.21
08L	US-FL/01-P08L/S	886.1001.080.21	US-FL/01-WZ08L	886.1002.080.21
10L	US-FL/01-P10L/S	886.1001.100.21	US-FL/01-WZ10L	886.1002.100.21
12L	US-FL/01-P12L/S	886.1001.120.21	US-FL/01-WZ12L	886.1002.120.21
15L	US-FL/01-P15L	886.1001.150.21	US-FL/01-WZ15L	886.1002.150.21
18L	US-FL/01-P18L	886.1001.180.21	US-FL/01-WZ18L	886.1002.180.21
22L	US-FL/01-P22L	886.1001.220.21	US-FL/01-WZ22L	886.1002.220.21
28L	US-FL/01-P28L	886.1001.280.21	US-FL/01-WZ28L	886.1002.280.21
35L	US-FL/01-P35L	886.1001.350.21	US-FL/01-WZ35L	886.1002.350.21
42L	US-FL/01-P42L	886.1001.420.21	US-FL/01-WZ42L	886.1002.420.21
06S	US-FL/01-P06L/S	886.1001.060.21	US-FL/01-WZ06S	886.1002.060.31
08S	US-FL/01-P08L/S	886.1001.080.21	US-FL/01-WZ08S	886.1002.080.31
10S	US-FL/01-P10L/S	886.1001.100.21	US-FL/01-WZ10S	886.1002.100.31
12S	US-FL/01-P12L/S	886.1001.120.21	US-FL/01-WZ12S	886.1002.120.31
14S	US-FL/01-P14S	886.1001.140.31	US-FL/01-WZ14S	886.1002.140.31
16S	US-FL/01-P16S	886.1001.160.31	US-FL/01-WZ16S	886.1002.160.31
20S	US-FL/01-P20S	886.1001.200.31	US-FL/01-WZ20S	886.1002.200.31
25S	US-FL/01-P25S	886.1001.250.31	US-FL/01-WZ25S	886.1002.250.31
30S	US-FL/01-P30S	886.1001.300.31	US-FL/01-WZ30S	886.1002.300.31
38S	US-FL/01-P38S	886.1001.380.31	US-FL/01-WZ38S	886.1002.380.31

Für jeden Rohr-Außendurchmesser (D1) sind je eine Gegenhalteplatte (1) und ein Werkzeugkonus (2) erhältlich. Beide sind mit der Größe beschriftet, um Verwechslungen vorzubeugen.

A counter plate (1) and a tool cone (2) are available for each tube diameter (D1). Both are labelled with the corresponding tube diameters to prevent confusion.

Se dispone de una placa de sujeción (1) y de un cono de herramienta (2) para cada diámetro exterior de tubo (D1). Ambos llevan rotulados sus tamaños para evitar confusiones.

Montagewerkzeuge unterliegen einem Verschleiß und müssen regelmäßig gereinigt und überprüft werden. Verschlissene Werkzeuge bitte umgehend ersetzen, sie können Fehlmontagen verursachen. Bei sachgemäßer Anwendung beträgt die Lebensdauer ca. 5000 Montagen.

Assembly tools are subject to wear and must be cleaned and checked on a regular basis. Worn tools must be replaced without delay to avoid incorrect assembly. When the tools are used as intended, they have a service life of approximately 5000 assemblies.





Las herramientas de montaje están sometidas a desgaste y deben limpiarse y verificarse con regularidad. Sustituya inmediatamente las herramientas desgastadas, pues pueden dar lugar a fallos de montaje. Si se utilizan correctamente, su vida útil es de aprox. 5000 montajes.

Dienstleistungen

Services

Servicios

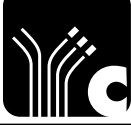

Dienstleistungen	Service	Servicio	
Übersicht	Overview	Vista general	
 s.3	Spezialreinigung / Spezialbehandlung	Special cleaning / Special treatment	Limpieza especial / Tratamiento especial
 s.4	Vorbeschichtete Einschraubgewinde mit Loctite 5061	Pre-coated male adaptor threads with Loctite 5061	Roscas de conexión recubiertas, con Loctite 5061
 s.5	Engineering	Engineering	Ingeniería
 s.6	Sonderanfertigungen	Special designed products	Modelos especiales
 s.7	Baugruppen	Pre-assembled kits	Grupos
 s.8	Konfektionierte Leitungen	Ready-to-fit pipes	Tuberías confeccionadas

Spezialreinigung / Spezialbehandlung

Special cleaning / Special treatment

Limpieza especial / Tratamiento especial



Reinigungsanlage

Reinigungsanlage mit 9 Sektionen, Ultraschall-Reinigungswanne mit Lauge, Säure und entionisiertem Wasser, getrennt durch Spülwannen mit Osmosewasser und komplettiert mit zwei Trocknungssektionen. Luftvorhang verhindert die Kontamination der gereinigten Teile mit Verschmutzungen aus der Luft.

Reinraum ISO Klasse 8

Montage und Verpackung der einzelnen Teile in separate Beutel in einem direkt an die Reinigungsanlage angrenzenden, klimatisierten Reinraum, der der ISO Klasse 8 entspricht. Eine jährlich stattfindende Validierung durch eine externe Prüfstelle garantiert die Einhaltung der vorgeschriebenen Werte.

Anwendungsgebiet

Überall, wo eine spezielle Oberflächensauberkeit der medienberührten Teile benötigt wird bieten wir gereinigten US-Teile an. Sie sind einerseits die Grundlage für unsere Optionen mit Spezialschmiermitteln (OX und SI), andererseits die richtige Lösung für Kunden mit eigenen Schmiermitteln. Die Teile durchlaufen die Reinigungsanlage und werden im Reinraum montiert, in Beutel einzeln eingeschweisst und verpackt.

Qualität

Oberflächensauberkeit
 < 33 mg/m² TOC gem. ASTM*
 G93, Level B
 Jeder Auftrag ist rückverfolgbar, Montage und Prüfung in speziell sauberer Umgebung.

*American Society for Testing and materials

Lieferumfang

- einzelverpackt in verschweissten PE-Beuteln
- Spezialetikett

Wichtiger Hinweis

Bitte klären Sie im Voraus unsere Möglichkeiten und Beschränkungen für spezifische Reinigungs- und Schmieroptionen für Ihre Teile genau ab.

Cleaning system

Cleaning plant consists of 9 sections, including an ultrasound cleaning bath with alkali, with acid and with de-ionised water, separated by rinsing baths with osmotic water and completed with two drying sections. A so-called air curtain prevents contamination of the cleaned components by dirt from the air.

Clean room ISO class 8

Assembly and packaging of the individual components into separate bags is carried out in an air-conditioned clean room which complies with ISO Class 8 directly next to the cleaning plant. An annual validation by an external testing laboratory guarantees compliance with the prescribed values.

Application area

Wherever special surface cleanliness is required for parts that come into contact with the media we offer cleaned US components. They form the basis of our options with special lubricants (OX and SI) and on the other hand are the right solution of customers who use their own lubricants. The components pass through the cleaning system and are assembled and individually packed in the ISO Class 8 clean room.

Quality

Surface cleanliness
 < 33 mg/m² TOC as per ASTM*
 G93, Level B
 Every order is traceable; assembly and testing are done in a special, clean environment.

*American Society for Testing and materials

Scope of supply

- individually packaged in heat-sealed PE bags
- special label

Important information

Please clarify in advance our possibilities and restrictions for specific cleaning and lubrication options for your components.

Sistema de limpieza

La planta de limpieza consta de 9 secciones, incluyendo un baño de limpieza por ultrasonido con álcali, con ácido y con agua desionizada, separadas por baños de enjuague con agua osmótica y completadas con dos secciones de secado. Una llamada cortina de aire evita la contaminación de los componentes limpiados por la suciedad del aire.

Sala limpia ISO clase 8

El ensamblaje y el embalaje de los componentes individuales en bolsas separadas se lleva a cabo en una sala limpia con aire acondicionado que cumple con la norma ISO Clase 8 directamente junto a la planta de limpieza. Una validación anual por un laboratorio de pruebas externo garantiza el cumplimiento de los valores prescritos.

Área de aplicación

Dondequiera que se requiera una limpieza especial de la superficie de las piezas que entran en contacto con los medios, ofrecemos componentes limpios US. Son la base de nuestras opciones con lubricantes especiales (OX y SI) y por otro lado son la solución correcta de los clientes que utilizan sus propios lubricantes. Los componentes pasan por el sistema de limpieza y se ensamblan y embalan individualmente en la sala limpia ISO Clase 8.

Calidad

Limpieza de la superficie
 < 33 mg/m² TOC según ASTM*
 G93, Nivel B
 Cada pedido es rastreado; el montaje y las pruebas se hacen en un ambiente especial y limpio.

*Sociedad Americana de Pruebas y materiales

Alcance del suministro

- empaquetados individualmente en bolsas de PE selladas
- etiqueta especial

Información importante

Por favor, aclare de antemano nuestras posibilidades y limitaciones para las opciones específicas de limpieza y lubricación de sus componentes.



Vorbeschichtete Einschraubgewinde mit Loctite 5061

Pre-coated male adaptor threads with Loctite 5061

Roscas recubiertas con Loctite 5061



Durch vorbeschichtete Gewinde erreichen Sie eine optimale Abdichtung von konischen Außengewinden.

Das wasserbasierte, nichthärtende und nichttoxische Gewindedichtmittel Loctite® 5061 wird maschinell aufgetragen. Auf diese Weise ist sichergestellt, dass die Dichtmasse gleichmäßig und direkt bei den potentiellen Leckagestellen im Gewindegrund und auf den Gewindeflanken aufgebracht wird. Dadurch wird optimal für höchste Dichtheit und Sicherheit gesorgt. Vorbeschichtete Gewinde von EXMAR sind vielseitig einsetzbar.

- Dichtmittel Loctite® 5061 Dri-Seal®
- montagefertig
- umweltfreundlich
- ungiftig, lösungsmittelfrei
- sehr gute Medienbeständigkeit
- Zulassung von: DVGW, KTW, SVGW

Technische Daten *

- chemische Basis: Polyacrylat wässrig, nicht härtend
- Temperatur: -50 °C bis +150 °C
- Druck (PN): 16 bar, andere Drücke möglich
- Justierbarkeit: 45° (DIN 30660)
- Einsatzmedien: Luft, Öl, Wasser (heiss, kalt)

Hinweis: Loctite® 5061 ist nicht geeignet für den Einsatz mit reinem Sauerstoff.

*Die Angaben stammen vom Hersteller von Loctite® 5061. Änderungen sind vorbehalten. Die Klärung der Einsatztauglichkeit von beschichteten Gewinden der EXMAR liegt in der Verantwortung des Konstrukteurs und muss vorgängig geprüft werden. EXMAR lehnt jegliche Haftung ab.

Bestellhinweis

EXMAR-Produkte, die mit beschichteten Gewinden geliefert werden sollen, müssen bei der Bestellung klar mit der Erweiterung **CT** nach der Materialnummer oder der Typenbezeichnung gekennzeichnet sein.

Beispiel: WEV-22LR 3.4 CT
oder 708.2406.768.21.CT

With pre-coated threads you obtain optimal sealing of tapered outside threads.

The water-based, non-hardening, non-toxic sealing compound Loctite® 5061 is applied by machine. This assures that the sealing compound is applied evenly and directly at potential leakage points at the base and the flank of the thread, thus providing extreme leak-tightness and reliability. Pre-coated threads from EXMAR may be used in a wide variety of applications.

- Loctite® 5061 Dri-Seal® sealing compound
- ready for assembly
- environmentally friendly
- non-toxic, solvent-free
- very good media resistance
- approved by: DVGW, KTW, SVGW

Technical Data *

- chemical base: polyacrylate, aqueous, non-hardening
- temperature: -50 °C to +150 °C
- pressure (PN): 16 bar, others possible
- adjustability: 45° (DIN 30660)
- media: air, oil, water (hot, cold)

Note: Loctite® 5061 is unsuitable for use with pure oxygen.

*The data comes from the manufacturer of Loctite® 5061. These are subject to change without notice. Clarification of the suitability for use of coated threads from EXMAR is the responsibility of the designer and must be carried out in advance. EXMAR will accept no liability there after.

Ordering information

EXMAR products which need to be supplied with coated threads must be clearly marked with **CT** after the material number or the type description when ordering.

e.g: WEV-22LR 3.4 CT
or 708.2406.768.21.CT

Las roscas recubiertas permiten conseguir un sellado óptimo de roscas exteriores cónicas.

El sellador de roscas Loctite® 5061, de base acuosa no endurecible, no tóxico, se aplica mediante procedimientos mecánicos. De este modo se asegura la aplicación uniforme y directa de la masa selladora en los posibles puntos de pérdida del fondo y de los flancos de la rosca para obtener una estanquidad y seguridad óptimas. Las roscas recubiertas de EXMAR tienen numerosas aplicaciones.

- sellador Loctite® 5061 Dri-Seal®
- listo para el montaje
- respetuoso con el medio ambiente
- no tóxico, no contiene disolventes
- muy buena resistencia a líquidos y gases
- homologaciones: DVGW, KTW, SVGW

Datos técnicos *

- base química: poliácridato acuoso, no endurecible
- temperatura: -50 °C a +150 °C
- presión (PN): 16 bar, otras presiones posibles
- margen de ajuste: 45° (DIN 30660)
- medios en los que se aplica: aire, aceite, agua (caliente, fría)

Advertencia: Loctite® 5061 no sirve para sellar oxígeno puro.

*Información proporcionada por el fabricante de Loctite® 5061. Reservado el derecho a realizar modificaciones. El fabricante que las utilice es el responsable de verificar de antemano la idoneidad de las roscas recubiertas de EXMAR para cada aplicación. EXMAR declina toda responsabilidad.

Instrucciones de pedido

Los productos EXMAR que deban suministrarse con roscas recubiertas han de identificarse inequívocamente con el suplemento **CT** después del número de material o de la denominación de tipo en el pedido.

Ejemplo: WEV-22LR 3.4 CT
o 708.2406.768.21.CT



**Engineering
Engineering
Ingeniería**

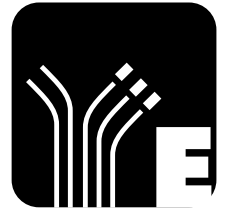

Maßgeschneiderte Lösungen – für Sie entwickelt von EXMAR Engineering

Beratung

Wir beraten Sie kompetent und mit großer Erfahrung in der Produktentwicklung. Sie bekommen von uns Lösungsvorschläge, die in der harten Realität bestehen können. Ihr Vorteil - unsere Erfahrung!

Engineering

Wir entwickeln für Sie maßgeschneiderte Produkte – zusammen mit Ihnen, wenn Sie wollen. Damit nur einwandfreie Ware unser Haus verläßt, prüfen wir alles vorher in unserem eigenen Labor. Sie erhalten nur einwandfreie und geprüfte Waren. Ihre Idee – unser Engineering!

Optimierte Produkte

Wir analysieren Ihre vorhandenen Produkte und spüren mögliches Optimierungspotenzial auf. Vielleicht lassen sich Fertigung und Montage oder die Herstellung vereinfachen. Sie erhalten dann durch ein Redesign optimierte Produkte. Ihre Einsparung – unsere Produktoptimierung!

EXMAR Engineering develops tailor-made solutions – also for you

Consulting

Our many years experience in product development enables us to advise you in a knowledgeable, competent manner and to propose appropriate application solutions. – Our experience is your advantage!

Engineering

In close co-operation with you and supported by the latest technology, we can develop the right products for your specific requirements. The quality of the components is validated internally, to ensure that only top-grade products leave our works – You provide the idea, we provide the engineering!

Product streamlining

We analyse, optimise and redesign. Existing products are examined meticulously and tested to determine whether manufacture and assembly can be optimised. Our redesigns simplify the manufacture of your products – EXMAR product streamlining saves you money!

Soluciones a su medida desarrolladas por EXMAR Engineering

Asesoramiento

Asesoramiento competente y amplia experiencia en el desarrollo de productos. Le propondremos soluciones que superarán con creces las duras condiciones del día a día. Su ventaja: nuestra experiencia.

Ingeniería

Desarrollamos para usted productos de ajuste preciso; si lo desea, puede colaborar en el proceso. Para que de nuestra fábrica solamente salgan productos en perfecto estado, los ensayamos a fondo en nuestro propio laboratorio. Recibirá exclusivamente productos inmaculados y verificados. Su idea: nuestra ingeniería.

Productos optimizados

Analizamos su gama de productos actual y exploramos posibles márgenes de optimización. Si consideramos que puede ser posible simplificar la producción y el montaje o la fabricación, recibirá productos optimizados en el marco de un rediseño. Su ahorro: nuestra optimización del producto.



Nutzen Sie bei der Konstruktion Ihrer Anlage unsere CAD-Bibliothek – exmar.partcommunity.com

Use our CAD library for the construction of your system – exmar.partcommunity.com

Utilice nuestra biblioteca CAD para la construcción de su sistema... exmar.partcommunity.com

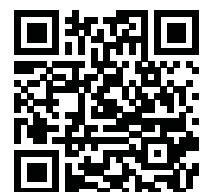

exmar.partcommunity.com

Sonderanfertigungen

Special designed products

Modelos especiales

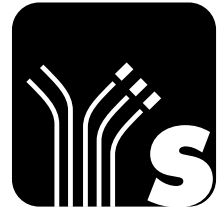

Schwierige Verbindungsaufgaben – Sonderanfertigungen von EXMAR

Herstellverfahren

Wir verfügen über modernst eingerichtete Produktions- und Bearbeitungswerkstätten. Zusammen mit großer Erfahrung im Pressen, Drehen oder Spritzen können wir Ihnen einwandfreie Produkte garantieren. Das schließt auch vor- oder nachgelagerte Prozesse wie Löten, Schweißen oder Oberflächenveredeln mit ein. Ihr Nutzen – unsere Vielseitigkeit!

Werkstoffe

Wir kennen uns in den Materialien aus. Vielfältige Herstellverfahren setzen auch Kenntnisse über die zu verarbeitenden Materialien voraus. Egal ob Edelstahl oder Sonderwerkstoffe wie Hastelloy®, Monel® usw., für jede Aufgabenstellung können wir das geeignete Material auswählen und verarbeiten. Sie erhalten den optimalen Werkstoff für Ihre Anwendung. Ihre Auswahl – unsere Materialvielfalt!

Funktionalität

Wir liefern unsere EXMAR Produkte für den Maschinen- und Apparatebau genauso wie für die Lebensmittel-, Pharma- oder Hightechindustrie. Überall hat sich die große Funktionalität bewährt. Sie erhalten individuelle Lösungen für genau Ihre spezielle Anwendung. Ihr Einsatzbereich – unsere Funktionalität

The special designs from EXMAR eliminate the problems that arise with connections

Manufacturing Process

Our hi-tech equipment in production and machining, as well as the wealth of experience in pressing, turning or spraying, enables us to guarantee you top-class products. Our other centres of excellence include brazing, welding and surface finishing offers you the complete manufacturing process

– Our versatility is your advantage!

Materials

Our varied manufacturing processes enable us to deal with a variety of material specifications. Irrespective of whether it is stainless steel or special material such as Hastelloy®, Monel®, etc., we have the necessary material and knowledge for the manufacture and you receive the ideal material for your application – material diversity is more important than ever!

Functionality

Due to their individual nature, EXMAR products can be found in a number of applications. These include mechanical engineering, food and beverage, water, heating and ventilation, pharmaceutical and other high-tech industries – optimized functionality, a maximum of application possibilities!

Tareas de conexión complejas, modelos especiales de EXMAR

Procedimiento de fabricación

Disponemos de centros de producción y elaboración con los equipamientos más modernos. Esto, unido a nuestra dilatada experiencia en el prensado, el torneado o la inyección, nos permite garantizar productos impecables e incluye también procesos anteriores o siguientes como, por ejemplo, la soldadura indirecta o directa o el afinado de superficies.

Su ventaja: nuestra versatilidad.

Materiales

Tenemos amplia experiencia en el campo de los materiales. Numerosos procedimientos de fabricación exigen conocimientos sobre los materiales que se procesan. Seleccionamos y elaboramos el material adecuado para cada tarea, ya sea acero inoxidable o materiales especiales como Hastelloy®, Monel®, etc.; usted recibirá siempre el material óptimo para su aplicación.

Su selección: nuestra diversidad de materiales.

Funktionalidad

Suministramos nuestros productos EXMAR tanto para la construcción de maquinaria y aparatos como a la industria alimentaria, farmacéutica o de alta tecnología; en todos los sectores se ha acreditado la extraordinaria funcionalidad. Recibirá soluciones personalizadas para su aplicación específica. Su campo de aplicación: nuestra funcionalidad.



Baugruppen
Pre-assembled kits
Grupos



Komplexe Aufgaben lösen – mit Baugruppen von EXMAR

With assemblies from EXMAR, you solve all the problems in one hit

Solución de tareas complejas con grupos de EXMAR

Von der Planung bis zur Distribution

Wir führen einzelne Komponenten zu Baugruppen zusammen. Für Sie übernehmen wir dabei die Planung, Fertigung und die gesamte Distribution.
Ihr Termin – unsere Lieferung just in time!

From planning to distribution

We fit individual components together to create assemblies. We undertake the planning, fabrication and distribution for you – Just in time with us as your partner!

Desde la planificación a la distribución

Combinamos componentes individuales en grupos y nos encargamos por usted de la planificación, la fabricación y la distribución completa. Su plazo: nuestra entrega en la fecha prevista (just in time)



Know-how

Wir haben das notwendige Know-how. Denn für unsere Kunden montieren wir täglich hunderte von Komponenten zu einbaufertigen Einheiten. Sie profitieren von unserem Wissen, denn das Gesamte ist mehr als die Summe der Einzelteile. Ihre Baugruppen – unsere Montagekompetenz!

Knowledge

EXMAR assembles hundreds of components on a daily basis to form ready-to-fit units. We have many years knowledge of pre-assembly experience – We can do this for you!

Conocimientos

Disponemos de los conocimientos necesarios. A diario ensamblamos cientos de componentes en unidades listas para montar para nuestros clientes. Usted se beneficia de nuestros conocimientos porque el conjunto es más que la suma de los elementos. Sus grupos: nuestra competencia de montaje.



Kostenvorteil

Wir wollen mit unserer Baugruppenfertigung Ihre Zeit sparen. Sie sparen aber nicht nur wertvolle Montagezeiten. Auch die Disposition, Logistik und Lagerbewirtschaftung gestaltet sich wesentlich einfacher, was Ihren Kosten gut tut. Ihr Kostenvorteil – unsere Bestrebung!

Cost-Benefits

With assemblies from EXMAR, you not only save valuable fitting time, but also simplifies the layout, logistics and inventory management and maintenance issues. This has a positive effect on reducing costs – Outsourcing, your cost-benefit!

Reducción de costes

El objetivo de nuestra fabricación de grupos es ahorrarle tiempo. Sin embargo, además de ahorrar precioso tiempo de montaje, se reducen costes en la planificación de necesidades, logística y gestión de almacenes. Su reducción de costes: nuestro afán.



Konfektionierte Leitungen

Ready-to-fit pipes

Tuberías confeccionadas

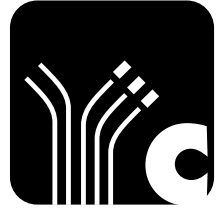

Einbaufertige Leitungen – EXMAR Top-Qualität

Ausführungen

Wir produzieren Ihre Rohrleitungen maßgeschneidert, passgenau und einbaufertig. Sie wählen aus einer Vielzahl von Rohrumformungs- und Konfektionierungsmöglichkeiten aus – gelötet oder geschweißt, gebogen oder gewickelt.

Ihr Anruf – unsere Leitung!

Materialien

Wir bieten Ihnen gerne Rohre in den verschiedensten Variationen an. Sie erhalten bei uns nicht nur Edelstahl, sondern auch Kupfer- oder Messingrohre. Oder sollen es gar warm verformte Kunststoffrohre sein? Wir machen es möglich.

Ihre Frage – unsere vielfältige Antwort!

Konfektionieren

Wir konfektionieren die gebogenen Leitungen nach Ihren Anforderungen und Wünschen. Sie bekommen Rohrleitungen, versehen mit EXMAR Armaturen, die sich mühelos ein- und ausbauen lassen.

With EXMAR you get top-quality, ready-to-fit pipes

Designs

Whether brazed or welded, curved or wound, EXMAR produces your pipes in a customised, ready-to-fit state. You have the possibility to select from a multitude of pipe shapes and manufacturing processes – Give us a call!

Materials

Pipes don't have to be made only from stainless steel! We can also offer you brass or copper pipes in a variety of different forms. Or do you require hot-formed plastic pipes? We can meet your specifications – Give us a try!

Ready-to-fit

We can assemble pipe work with EXMAR fittings according to your specifications. Pipes with EXMAR fittings can be installed or removed without difficulty.

Tuberías listas para instalar: calidad puntera EXMAR

Versiones

Producimos sus tuberías a medida, con precisión de ajuste y listas para instalar. Puede elegir entre numerosas posibilidades de conformado y confección de tuberías: soldadura indirecta o directa, doblado o enrollado.

Su llamada: nuestra línea.

Materiales

Ofrecemos tubos en todo tipo de variantes. Además de tubos de acero inoxidable, podemos suministrar también tubos de cobre, latón o incluso tubos de plástico deformados en caliente. Nosotros lo hacemos posible.

Su pregunta: nuestra respuesta múltiple.

Confeccionado

Confeccionamos las tuberías dobladas con arreglo a sus especificaciones. Le suministraremos tuberías equipadas con valvulerías EXMAR sumamente fáciles de montar y desmontar.

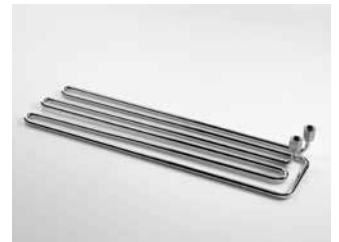

Anhang

**Technische Erläuterungen
Beständigkeitsliste**

Appendix

**Technical information
Chemical resistances**

Anexo

**Datos técnicos
Resistencia a sustancias
químicas**



Anhang	Appendix	Anexo
Übersicht	Overview	Resumen
		Seite / Page / Pagina
Gewindebestimmung Identification of threads Determinación de las roscas		a.3
Einschraubzapfen und -löcher für Rohrverschraubungen Stud and port forms for tube fittings Vástagos y agujeros roscados para uniones de tubos		a.4 - a.7
Eigenschaften von Dichtungswerkstoffen bei EXMAR-Produkten Properties of sealing materials in EXMAR products Características de los materiales de en los productos EXMAR		a.8 - a.9
Beständigkeitsliste List of chemical resistance Lista del resistencia a sustancias químicas		a.10 - a.20
Allgemeine Verkaufs- und Lieferbedingungen General terms of sale and delivery Condiciones generales de venta y entrega		a.21 - a.25

Gewindebestimmung Identification of threads Determinación de roscas

Aussengewinde Male thread Rosca exterior	Innengewinde Female thread Rosca interior																																																		
	1 	2 	3 																																																
Metrisches ISO-Regelgewinde Metric thread Rosca métrica ISO	Metrisches ISO-Feingewinde Metric fine thread Rosca métrica fina ISO	Rohrgewinde BSPP BSPP Pipe thread Rosca para tubos BSPP	Rohrgewinde BSPT BSPT Pipe thread Rosca para tubos BSPT																																																
<table border="0"> <tr><td>M 3</td><td></td></tr> <tr><td>M 4</td><td></td></tr> <tr><td>M 5</td><td></td></tr> <tr><td>M 6</td><td></td></tr> <tr><td>M 8</td><td></td></tr> <tr><td>M 10</td><td></td></tr> <tr><td>M 12</td><td></td></tr> </table>	M 3		M 4		M 5		M 6		M 8		M 10		M 12		<table border="0"> <tr><td>M 10x1</td><td></td></tr> <tr><td>M 12x1</td><td></td></tr> <tr><td>M 14x1</td><td></td></tr> <tr><td>M 16x1</td><td></td></tr> <tr><td>M 16x1.5</td><td></td></tr> </table>	M 10x1		M 12x1		M 14x1		M 16x1		M 16x1.5		<table border="0"> <tr><td>G 1/8</td><td></td></tr> <tr><td>G 1/4</td><td></td></tr> <tr><td>G 3/8</td><td></td></tr> <tr><td>G 1/2</td><td></td></tr> <tr><td>G 3/4</td><td></td></tr> <tr><td>G1</td><td></td></tr> </table>	G 1/8		G 1/4		G 3/8		G 1/2		G 3/4		G1		<table border="0"> <tr><td>R 1/8</td><td></td></tr> <tr><td>R 1/4</td><td></td></tr> <tr><td>R 3/8</td><td></td></tr> <tr><td>R 1/2</td><td></td></tr> <tr><td>R 3/4</td><td></td></tr> <tr><td>R 1</td><td></td></tr> </table>	R 1/8		R 1/4		R 3/8		R 1/2		R 3/4		R 1	
M 3																																																			
M 4																																																			
M 5																																																			
M 6																																																			
M 8																																																			
M 10																																																			
M 12																																																			
M 10x1																																																			
M 12x1																																																			
M 14x1																																																			
M 16x1																																																			
M 16x1.5																																																			
G 1/8																																																			
G 1/4																																																			
G 3/8																																																			
G 1/2																																																			
G 3/4																																																			
G1																																																			
R 1/8																																																			
R 1/4																																																			
R 3/8																																																			
R 1/2																																																			
R 3/4																																																			
R 1																																																			

Einschraubzapfen und -löcher für Rohrverschraubungen **Stud and port forms for tube fittings** **Vástagos y agujeros roscados para racores de tubos**

Metallische Abdichtung durch Dichtkante **Metal-to-metal sealing** **Cierre hermético mediante borde de obturación metálico**

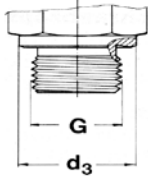
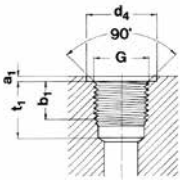
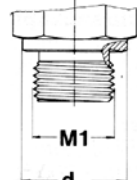
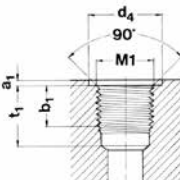
Whitworth-Rohrgewinde (zylindrisch) ISO 228-1 BSP thread (parallel) ISO 228-1 Rosca Whitworth para tubos (cilíndrica) ISO 228-1	Einschraubzapfen: DIN 3852-2 Abdichtung durch Dichtkante Form B Studs: DIN 3852-2 sealing edge form B Vástagos roscados: DIN 3852-2 cierre hermético mediante borde de obturación forma B	
	Einschraublöcher: DIN 3852-2 Form X Ports: DIN 3852-2 form X Agujeros roscados: DIN 3852-2 forma X	
Metrisches ISO-Gewinde (zylindrisch) DIN 13 Metric ISO thread (parallel) DIN 13 Rosca métrica ISO (cilíndrica) DIN 13	Einschraubzapfen: DIN 3852-1 Abdichtung durch Dichtkante Form B Studs: DIN 3852-1 sealing edge form B Vástagos roscados: DIN 3852-1 cierre hermético mediante borde de obturación forma B	
	Einschraublöcher: DIN 3852-1 Form X Ports: DIN 3852-1 form X Agujeros roscados: DIN 3852-1 forma X	

Einschraubzapfen Studs Vástagos roscados	Einschraublöcher Ports Agujeros roscados	Einschraubzapfen Studs Vástagos roscados	[mm]	[mm]	[mm]	[mm]	[mm]
G	G	M1	d3	d4	a1 max.	b1 min.	t1 min.
-	-	M 8 x 1,0	12	13	1,0	8	10
G 1/8 A	G 1/8	M 10 x 1,0	14	15	1,0	8	10
-	-	M 12 x 1,5	17	18	1,5	12	15
G 1/4 A	G 1/4	-	18	20	1,5	12	15
-	-	M 14 x 1,5	19	20	1,5	12	15
-	-	M 16 x 1,5	21	23	1,5	12	15
G 3/8 A	G 3/8	-	22	23	2,0	12	18,5
-	-	M 18 x 1,5	23	25	2,0	12	15
G 1/2 A	G 1/2	-	26	28	2,5	14	22
-	-	M 20 x 1,5	25	27	2,0	14	17
-	-	M 22 x 1,5	27	28	2,5	14	17
-	-	M 26 x 1,5	31	33	2,5	16	19
G 3/4 A	G 3/4	M 27 x 2,0	32	33	2,5	16	20
G 1 A	G 1/1	M 33 x 2,0	39	41	2,5	18	22
G 1 1/4 A	G 1 1/4	M 42 x 2,0	49	51	2,5	20	24
G 1 1/2 A	G 1 1/2	M 48 x 2,0	55	56	2,5	22	31

Einschraubzapfen und -löcher für Rohrverschraubungen (Forts.) **Stud and port forms for tube fittings** (cont.) **Vástagos y agujeros roscados para racores de tubos** (cont.)

Elastomere Abdichtung durch Weichdichtung Soft sealing with elastomer seal Cierre hermético elastomérico mediante junta blanda

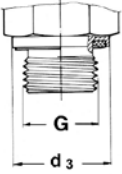
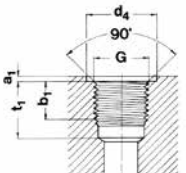
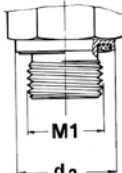
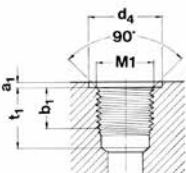
Whitworth-Rohrgewinde (zylindrisch) ISO 228-1 BSP thread (parallel) ISO 228-1 Rosca Whitworth para tubos (cilíndrica) ISO 228-1	Einschraubzapfen: ISO 1179-2 Abdichtung durch Profildichtring Form E* Studs: ISO 1179-2 profile sealing ring form E* Vástagos roscados: ISO 1179-2 cierre hermético mediante junta con perfil forma E*	
	Einschraublöcher: ISO 1179-1 Ports: ISO 1179-1 Agujeros roscados: ISO 1179-1	
Metrisches ISO-Gewinde (zylindrisch) DIN 13 Metric ISO thread (parallel) DIN 13 Rosca métrica ISO (cilíndrica) DIN 13	Einschraubzapfen (früher DIN 3852-11) Abdichtung durch Profildichtring Form E* Studs (former DIN 3852-11) profile sealing ring form E* Vástagos roscados (antes DIN 3852-11) cierre hermético mediante junta con perfil forma E*	
	Einschraublöcher: ISO 1179-1 Ports: ISO 1179-1 Agujeros roscados: ISO 1179-1	

(* -20°C – +200°C)

Einschraubzapfen Studs Vástagos roscados	Einschraublöcher Ports Agujeros roscados	Einschraubzapfen Studs Vástagos roscados	[mm]	[mm]	[mm]	[mm]	zoll inch inglesa [mm]	metrisch metric métrica [mm]
G	G	M1	d3	d4	a1 max.	b1 min.	t1 min.	t1 min.
-	-	M 8 x 1,0	12	13	1,0	8	-	10
G 1/8 A	G 1/8	M 10 x 1,0	13,9	15	1,0	8	10	10
-	-	M 12 x 1,0	16,9	18	1,5	12	-	15
G 1/4 A	G 1/4	-	18,9	20	1,5	12	15	-
-	-	M 14 x 1,0	18,9	20	1,5	12	-	15
-	-	M 16 x 1,5	21,9	23	1,5	12	-	15
G 3/8 A	G 3/8	-	21,9	23	2,0	12	15	-
-	-	M 18 x 1,5	23,9	25	2,0	12	-	15
-	-	M 20 x 1,5	25,9	27	2,0	14	-	17
G 1/2 A	G 1/2	-	26,9	28	2,5	14	18	-
-	-	M 22 x 1,5	26,9	28	2,5	14	-	17
-	-	M 26 x 1,5	31,9	33	2,5	16	-	19
G 3/4 A	G 3/4	M 27 x 2,0	31,9	33	2,5	16	20	20
G 1 A	G 1/1	M 33 x 2,0	39,9	41	2,5	18	23	22
G 1 1/4 A	G 1 1/4	M 42 x 2,0	49,9	51	2,5	20	25	24
G 1 1/2 A	G 1 1/2	M 48 x 2,0	54,9	56	2,5	22	27	31

Einschraubzapfen und -löcher für Rohrverschraubungen (Forts.) **Stud and port forms for tube fittings** (cont.) **Vástagos y agujeros roscados para racores de tubos** (cont.)

Dichtmittel im Gewinde dichtend **Sealing material in the thread** **Material de obturación hermetizante en rosca**

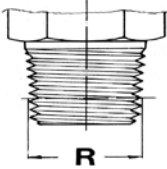
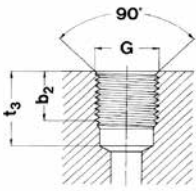
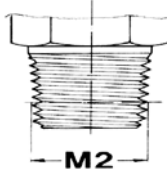
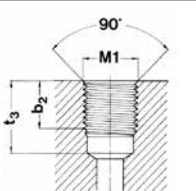
<p>Whitworth-Rohrgewinde (kegelig) EN 10226-1</p> <p>BSP thread (taper) EN 10226-1</p> <p>Rosca Whitworth para tubos (cónica) EN 10226-1</p>	<p>Einschraubzapfen: DIN 3852-2 Abdichtung im Kegелgewinde Form C</p> <p>Studs: DIN 3852-2 taper thread sealing form C</p> <p>Vástagos roscados: DIN 3852-2 cierre hermético con rosca cónica forma C</p>	
	<p>Einschraublöcher: DIN 3852-1 Form Z, nur für Einschraubzapfen Form C</p> <p>Ports: DIN 3852-1 form Z, for taper stud threads form C only</p> <p>Agujeros roscados: DIN 3852-1 forma Z, sólo para vástagos roscados forma C</p>	
<p>Metrisches ISO-Gewinde (kegelig) DIN 158</p> <p>Metric ISO thread (taper) DIN 158</p> <p>Rosca métrica ISO (cónica) DIN 158</p>	<p>Einschraubzapfen: DIN 3852-1 Abdichtung im Kegелgewinde Form C</p> <p>Studs: DIN 3852-1 taper thread sealing form C</p> <p>Vástagos roscados: DIN 3852-1 cierre hermético con rosca cónica forma C</p>	
	<p>Einschraublöcher: DIN 3852-1 Form Z, nur für Einschraubzapfen Form C</p> <p>Ports: DIN 3852-1 form Z, for taper stud threads form C only</p> <p>Agujeros roscados: DIN 3852-1 forma Z, sólo para vástagos roscados forma C</p>	

Einschraubzapfen Studs Vástagos roscados	Einschraublöcher Ports Agujeros roscados	Einschraubzapfen Studs Vástagos roscados	Einschraublöcher Ports Agujeros roscados	[mm]	zoll inch inglesa [mm]	metrisch metric métrica [mm]
R	G	M2	M1	b2	t3	t3
-	-	M 8 x 1,0 keg.	M 8 x 1,0	5,5	-	10,0
R 1/8"	G 1/8	-	-	5,5	8,5	-
-	-	M10 x 1,0 keg.	M 10 x 1,0	5,5	-	10,0
R 1/4"	G 1/4	M12 x 1,5 keg.	M 12 x 1,5	8,5	12,5	12,5
-	-	M14 x 1,5 keg.	M 14 x 1,5	8,5	-	13,5
R 3/8"	G 3/8	M16 x 1,5 keg.	M 16 x 1,5	8,5	12,5	12,5
-	-	M18 x 1,5 keg.	M 18 x 1,5	8,5	-	13,5
R 1/2"	G 1/2	M20 x 1,5 keg.	M 20 x 1,5	10,5	16,5	15,5
-	-	M22 x 1,5 keg.	M 22 x 1,5	10,5	-	15,5

Einschraubzapfen und -löcher für Rohrverschraubungen (Forts.)

Stud and port forms for tube fittings (cont.)

Vástagos y agujeros roscados para racores de tubos (cont.)

Dichtmittel im Gewinde dichtend

Sealing material in the thread

Material de obturación hermetizante en rosca

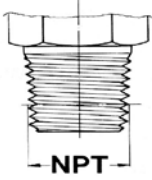
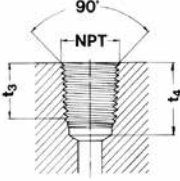
<p>Einschraubzapfen: mit NPT Gewinde nach ANSI B. 1.20.1</p> <p>Studs: with NPT thread to ANSI B. 1.20.1</p> <p>Vástagos roscados: con rosca NPT según ANSI B. 1.20.1</p>	
<p>Einschraublöcher: mit NPT Gewinde nach ANSI B. 1.20.1</p> <p>Ports: with NPT thread to ANSI B. 1.20.1</p> <p>Agujeros roscados: con rosca NPT según ANSI B. 1.20.1</p>	

ANSI B. 1.20.1		
NPT	t4	t3
1/8	11,6	6,9
1/4	16,4	10
3/8	17,4	10,3
1/2	22,6	13,6
3/4	23,1	14,1
1	27,8	16,8
1 1/4	28,3	17,3
1 1/2	28,3	17,3

R - zölliges, kegeliges Gewinde
R - BSP tapered thread
R - rosca cónica BSP

ohne Kennzeichnung
without marking
sin etiquetado

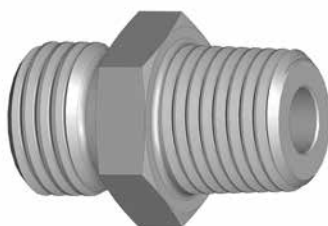

Mk - metrisches, kegeliges Gewinde
Mk - metric, tapered thread
Mk - rosca métrica, cónica

Absatz am Auslauf des Gewindes
offset at the outlet of the thread
sección en la salida de la rosca

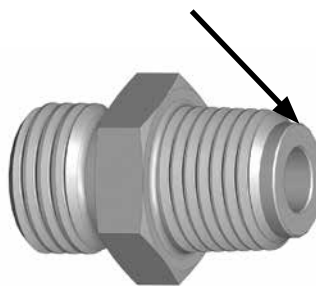

NPT - NPT Gewinde
NPT - NPT thread
NPT - rosca NPT

große Phase in Durchgangsbohrung
large phase in through hole
gran fase en agujero pasante

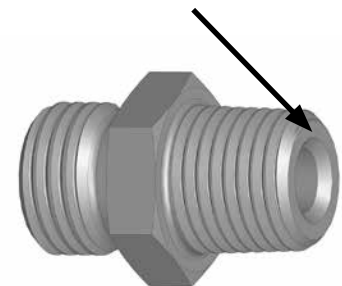

Eigenschaften von Dichtungswerkstoffen bei EXMAR-Produkten

Properties of sealing materials in EXMAR products

Características de los materiales de en los productos EXMAR

Standard

FKM/FPM – Fluorkautschuk

Fluorelastomer zählt zu den bedeutendsten Werkstoffentwicklungen der 50er Jahre. Der Unterschied zwischen FPM und FKM liegt nur in der Bezeichnung: FPM (nach DIN / ISO) und FKM (nach ASTM). Der Ausgangswerkstoff ist FDA-konform (CFR 21, §177.2600). Es ist auch unter dem Handelsnamen Viton® bekannt.

FKM zeichnet sich durch hohe Temperatur-, Witterungs-, Ozon- und Chemikalienbeständigkeit aus. Der thermische Anwendungsbereich reicht von -20°C bis +200°C, kurzzeitig +250°C.

FKM ist gegenüber fast allen Hydraulikflüssigkeiten auf Mineralölbasis und synthetischer Basis hoch beständig, ebenso gegen Ozon, Sauerstoff, Kraftstoffe, Aromate, viele organische Lösungsmittel und Chemikalien. Einschränkungen müssen für den Einsatz in Heisswasser, Dampf und bei Tieftemperaturen gemacht werden. Auf Grund nur geringer Kälteflexibilität und mässiger Heisswasser- und Dampfbeständigkeit sind für diesen Einsatz spezielle Werkstoffe zu wählen. Nicht beständig ist FKM ausserdem gegen polare Lösungsmittel wie Aceton, Bremsflüssigkeiten auf Glykolbasis, Ammoniakgas, Alkalien und niedermolekulare organische Säuren (Ameisensäure und Essigsäure).

Auf Anfrage

PEEK – Polyetheretherketon

PEEK ist einer der wichtigsten Vertreter der thermoplastischen PTFE-Kunststoffe, der seine hervorragenden Eigenschaften bis zu Temperaturen von +260°C hält.

PEEK ist sehr beständig gegen Wasserdampf, Hydrolyse, Kraftstoffe, Alkohole, Fette, Öle und Laugen. Das Material wird z.B. eingesetzt bei Führungsringen, Kugelhahnsitzen, etc., die höchsten Anforderungen entsprechen müssen. Es ist auch sehr gut geeignet für Tieftemperaturen bis -100°C.

EPDM – Ethylen-Propylen-Dien-Elastomer

EPDM Elastomere sind sehr alterungs- und witterungsbeständig, auch bei UV-Belastung und Ozonbelastung. Sie weisen geringe Wasserdampfdurchlässigkeit und extrem tiefe Versprödungstemperaturen auf. Wegen seiner hohen Elastizität und guten chemischen Beständigkeit wird EPDM für verschiedenste Dichtungen wie z.B. O-Ringe und Flachdichtungen verwendet. Die Einsatztemperatur liegt zwischen -40°C und +160°C, kurzzeitig bis +180°C.

EPDM hat eine ausgezeichnete Beständigkeit gegen Heisswasser und Wasserdampf und eine gute Beständigkeit gegen polare Flüssigkeiten wie Aceton, Methanol usw. Nicht beständig ist der Werkstoff gegenüber aliphatischen und aromatischen Kohlenwasserstoffe. (Mineralöle, Benzin, Kraftstoffe) und Fetten.

FFKM/FFPM – Perfluorkautschuk

Chemisch ist FFKM dem Polytetrafluorethylen (PTFE) sehr ähnlich und verbindet die Elastizität und die Dichtungskraft eines echten Elastomers mit der chemischen Beständigkeit von PTFE. Verglichen mit rein PTFE-Dichtungen zeigen FFKM-Teile kein Wegkriechen, kein Fließen und geringe bleibende Verformung.

Standard

FKM/FPM – Fluorocarbon rubber

Fluororubber figures among the most significant developments in materials technology of the 1950s. The difference between FPM and FKM is only the name: FPM (according to DIN / ISO) and FKM (according to ASTM). The initial material is FDA-compatible (CFR 21, §177.2600). It is also known under the trading name Viton®.

FKM features high temperature, weathering, ozone and chemical resistance. The temperature application range is from -20°C to +200°C, short term +250°C.

FKM is highly resistant to nearly all mineral-oil and synthetic-based hydraulic fluids, as well as to ozone, oxygen, fuels, aromatic compounds, many organic solvents and chemicals. There are however restrictions for use in hot water, steam and at low temperatures. Due to the diminished low-temperature flexibility and moderate hot water and steam resistance, special materials should be selected for these applications. FKM is also not resistant to polar solvents, such as acetone, glycol-based brake fluids, ammonia gas, alkalis and low molecular-weight organic acids (formic acid and acetic acid).

On request

PEEK – Polyetheretherketone

PEEK is one of the most important representatives of the thermoplastic PTFE plastics which maintains its excellent properties up to temperatures of +260°C.

PEEK is very resistant to water vapour, hydrolysis, fuels, alcohols, greases, oils and alkalis. The material is used for example in guide rings, ball valve hubs etc. that have to meet the highest requirements. It is also well suited to low temperatures down to -100°C.

EPDM – Ethylene-Propylene-Diene-Rubber

EPDM elastomers are very resistant to ageing and weathering, even with UV exposure and ozone influence. They exhibit low water vapour permeability and extremely low brittleness temperature. Due to its high elasticity and good chemical resistance, EPDM is used for diverse seals, such as e.g. O-rings and flat gaskets. The working temperature ranges from -40°C to +160°C, short term up to +180°C.

EPDM possesses excellent resistance to hot water and steam and good resistance to polar liquids, such as acetone, methanol, etc. The material is not resistant to aliphatic and aromatic hydrocarbons (mineral oils, benzene, fuels) and greases.

FFKM/FFPM – Perfluoroelastomer

Chemically, FFKM is very similar to polytetrafluorethylene (PTFE) and it combines the elasticity and sealing strength of a true elastomer with the chemical resistance of PTFE. Compared to pure PTFE seals, FFKM parts do not demonstrate creep behaviour or yield and little permanent deformation. FFKM perfluoroelastomer

Standard

FKM/FPM – caucho fluorado

El fluoroelastomero es uno de los más importantes desarrollos de material de los años 50. La diferencia entre FPM y FKM solamente afecta a la denominación: FPM (según DIN / ISO) y FKM (según ASTM). El material de partida cumple la FDA (CFR 21, art. 77.2600). También se conoce por el nombre comercial de Viton®.

FKM se caracteriza por una elevada resistencia a la temperatura, los agentes meteorológicos, el ozono y las sustancias químicas. El rango de aplicación térmica va desde -20°C a +200°C, brevemente hasta +250°C.

FKM es altamente resistente a casi todos los líquidos hidráulicos sobre base de aceite mineral y sintética, así como al ozono, oxígeno, combustibles, compuestos aromáticos, multitud de disolventes y sustancias químicas orgánicas. Es necesario establecer restricciones para el uso en agua caliente, vapor y a bajas temperaturas. Debido a la limitada flexibilidad en frío y la moderada resistencia al agua caliente y al vapor, para tales aplicaciones deben seleccionarse materiales especiales. Además, FKM no es resistente a disolventes polares como la acetona, los líquidos de frenos sobre base de glicol, el gas amoniaco, las sustancias alcalinas y los ácidos orgánicos de baja molecularidad (ácido fórmico y ácido acético).

A petición

PEEK – polieteretercetona

PEEK es uno de los principales productos representativos de los termoplásticos PTFE, que conserva sus excelentes propiedades hasta temperaturas de +260°C.

PEEK es altamente resistente al vapor de agua, hidrólisis, combustibles, alcoholes, grasas, aceites y lejías. El material se utiliza, por ejemplo, en anillos guía, asientos de llaves esféricas, etc., que han de hacer frente a las exigencias más elevadas. Resulta idóneo asimismo para bajas temperaturas hasta de -100°C.

EPDM – elastómero etileno propileno dieno

Los elastómeros EPDM son altamente resistentes al envejecimiento y los agentes meteorológicos, incluso bajo la acción de radiación ultravioleta y de ozono. Presentan una reducida permeabilidad al vapor de agua y temperaturas de fragilización extremadamente bajas. Debido a su elevada elasticidad y buena resistencia química, EPDM se utiliza para las juntas más diversas, como por ejemplo anillos tóricos y juntas planas. La temperatura de utilización varía entre -40°C y +160°C, brevemente hasta +180°C.

EPDM presenta una resistencia excepcional al agua caliente y el vapor de agua y una buena resistencia a líquidos polares como acetona, metanol, etc. Este material no es resistente a hidrocarburos alifáticos y aromáticos, (aceites minerales, bencina, combustibles) y grasas.

FFKM/FFPM – caucho de perfluoruro

FFKM es químicamente muy similar al politetrafluoretileno (PTFE) y combina la elasticidad y la fuerza de obturación de un auténtico elastómero con la resistencia química del PTFE. En comparación con juntas de PTFE puro, las piezas de FFKM no presentan escurrimiento ni fluencia y una reducida deformación permanente. Las

FFKM-Perfluor-Elastomer Teile bewahren ihre elastischen Eigenschaften im Langzeitbetrieb von bis zu +315 °C und im periodischen Betrieb bis zu +350 °C selbst in Berührung mit korrosiven Chemikalien.

Wegen seines vergleichsweise hohen kg-Preises ist der Einsatz auf Anwendungen beschränkt, bei denen es im Kontakt mit sehr aggressiven Medien steht, besonders hohe Sicherheits- oder Reinheitsanforderungen bestehen oder mögliche hohe Störfallkosten den Einsatz rechtfertigen. Dies kann beispielsweise in der chemischen, der erdölfördernden und -verarbeitenden Industrie, dem Apparate- und Kraftwerksbau, der Halbleiter-, der Lebensmittelindustrie oder in der Luft- und Raumfahrt der Fall sein.

FFKM-Teile widerstehen dem Angriff von nahezu allen Chemikalien wie z.B. Äther, Lösungsmittel, Ketone, Ester, Amine, Kraftstoffe, Säuren und Laugen.

PTFE – Polytetrafluorethylen

PTFE ist aufgrund seiner hervorragenden chemischen, physikalischen, thermischen und elektrischen Eigenschaften ein wichtiger Werkstoff für die verschiedensten Industriezweige. Der Werkstoff ist in reiner Form physiologisch unbedenklich und FDA-konform (CFR 21, § 177.1550). Die Einsatztemperatur liegt zwischen -200 °C bis +260 °C (kurzzeitig bis +300 °C). PTFE hat einen ausgesprochen niedrigen Reibungskoeffizienten, neigt jedoch zum Kaltfluss und hat nur geringe Druck- und Verschleissfestigkeit.

PTFE ist beständig gegen nahezu alle organischen und anorganischen Chemikalien (ausser elementares Fluor unter Druck oder bei hohen Temperaturen, Fluor-Halogen-Verbindungen und Alkalimetallschmelzen). Bei Raumtemperatur ist PTFE physiologisch stabil, der Kontakt mit aggressiven Medien ändert die Werkstoffeigenschaften nicht.

VMQ – Silikon-Elastomer

VMQ® zeichnet sich besonders durch den grossen thermischen Anwendungsbereich aus. Die sehr gute Kälteflexibilität, die gute Ozonbeständigkeit und die guten dielektrischen Eigenschaften sind weitere Vorteile. Schlechter als bei anderen Elastomeren ist die Gasdurchlässigkeit. Die Einsatztemperatur liegt zwischen -60 °C und +250 °C.

NBR – Acrylnitril-Butadien-Elastomer

Die Kurzbezeichnung NBR ist abgeleitet von Nitrile Butadiene Rubber. NBR ist wegen der guten Beständigkeit gegen die meisten Öle und Fette auf Mineralölbasis der in der Dichtungstechnik am häufigsten eingesetzte Werkstoff. Der thermische Einsatzbereich liegt normalerweise zwischen -30 °C und +100 °C, kurzzeitig bis +130 °C; bei höheren Temperaturen verhärtet der Werkstoff. Ausserdem zeigt NBR ein günstiges Alterungsverhalten und geringen Abrieb.

NBR ist beständig gegen Hydrauliköle, Wasserglykole und Öl in Wasser-Emulsionen, Mineralöle und Mineralölprodukte, tierische und pflanzliche Öle, Benzin, Heizöl, Wasser bis ca. +70 °C, Butan, Propan, Methan, Ethan. Stark quellend ist NBR bei aromatischen Kohlenwasserstoffen (z.B. Benzol), chlorierten Kohlenwasserstoffen (z.B. Trichlorethylen), Estern, polaren Lösungsmitteln wie Aceton sowie in Bremsflüssigkeiten auf Glykoletherbasis.

NBR – LT

NBR-LT (Low Temperature) besitzt die gleichen Beständigkeiten und Eigenschaften wie NBR bei einem thermischen Einsatzbereich von -50 °C bis +100 °C.

parts maintain their elastic properties in long-term operation at up to +315 °C and in periodic operation up to +350 °C, even when in contact with corrosive chemicals.

Because of its comparably high kilogram price, the applications are limited to those with contact to highly aggressive media, particularly in situations where there are high safety and purity specifications or where the costs in the event of failure would be very high. Such applications are found, for example, in the chemical, petroleum producing and processing industries, equipment manufacturing, power plant construction, semiconductor and food industries or in the aerospace industry.

FFKM parts are resistant to nearly all chemicals, such as ethers, solvents, ketones, esters, amines, fuels, acids and alkalis.

PTFE – Polytetrafluoroethylene

Due to its outstanding chemical, physical, thermal and electrical properties, PTFE is an important material in a variety of industrial sectors. The material is non-toxic in its pure form and FDA-compatible (CFR 21, § 177.1550). The working temperature is between -200 °C and +260 °C (short term up to +300 °C). PTFE has an exceptionally low coefficient of friction, tends, however, to cold flow and only has low resistance to pressure and wear.

PTFE is resistant to nearly all organic and inorganic chemicals (except elementary fluorine under pressure or at high temperatures, fluorine-halogen compounds and alkali metal fusions). At room temperature, PTFE is physiologically stable; contact with aggressive media does not alter its material properties.

VMQ – Silicone-Elastomer

VMQ is particularly characterised by its broad range of thermal application. The very good cold flexibility, the good ozone resistance and the good dielectric properties are additional advantages. The gas permeability is not as favourable as with other elastomers. The working temperature range is between -60 °C and +250 °C.

NBR – Acrylonitrile-Butadiene-Elastomer

The abbreviation NBR stands for Nitrile Butadiene Rubber. NBR is the most frequently used material in sealing technology because of its good resistance to most mineral oils and greases. The thermal range of application is normally between -30 °C and +100 °C, short term up to +130 °C; at higher temperatures the material hardens. Additionally, NBR exhibits favourable ageing characteristics and low surface abrasion.

NBR is resistant to hydraulic oils, water glycols and oils in aqueous emulsions, mineral oils and mineral-oil products, animal and vegetable oils, benzene, fuel oil, water up to ca. +70 °C, butane, propane, methane, ethane. NBR swells greatly with aromatic hydrocarbons, e.g. benzene, chlorinated hydrocarbons (e.g. trichloroethylene), esters, polar solvents, such as acetone, as well as in glycol ether-based brake fluids.

NBR – LT

NBR-LT (Low Temperature) has the same durability and properties as NBR with a thermal application range of -50 °C to +100 °C.

piezas de elastómero de perfluoruro FFKM conservan las características elásticas durante el funcionamiento prolongado a temperaturas de hasta +350 °C, incluso en contacto con sustancias químicas corrosivas.

Debido a su comparativamente elevado precio por kilogramo, su utilización está restringida a aplicaciones en que entre en contacto con medios muy agresivos, si existen elevados requisitos en cuanto a seguridad y limpieza o cuando su uso esté justificado por los posibles elevados costes derivados de un fallo. Tal puede ser el caso, por ejemplo, en la industria química, de prospección y procesamiento del petróleo, la construcción de equipamientos y centrales eléctricas, la industria de los semiconductores, el sector alimentario o la navegación aérea y espacial.

Las piezas de FFKM soportan la agresión de todas las sustancias químicas como, por ejemplo, éter, disolventes, cetonas, ésteres, aminas, combustibles, ácidos y lejías.

PTFE – politetrafluoretileno

El PTFE constituye, gracias a sus excepcionales características químicas, físicas, térmicas y eléctricas, un material importante para los más diversos sectores de la industria. El material es, en estado puro, fisiológicamente inocuo y cumple la FDA (CFR 21, art. 177.1550). La temperatura de utilización varía entre -200 °C y +260 °C (brevemente hasta 300 °C). PTFE presenta un coeficiente de rozamiento notablemente reducido, aunque propende al flujo en frío y posee una reducida resistencia a la presión y al desgaste.

PTFE es resistente a la casi totalidad de sustancias químicas orgánicas e inorgánicas (excepto el flúor elemental bajo presión o a temperaturas elevadas, compuestos, de flúor-halógenos y materiales licuados de metales alcalinos). A temperatura ambiente, el PTFE es fisiológicamente estable, el contacto con medios agresivos no altera las características del material.

VMQ – elastómero de silicona

VMQ se caracteriza especialmente por el amplio rango de aplicación térmica. Otras ventajas adicionales son la magnífica flexibilidad en frío, la buena resistencia al ozono y las notables propiedades dieléctricas. La permeabilidad a los gases es peor que la de otros elastómeros. La temperatura de utilización se encuentra entre -60 °C y +250 °C.

NBR – elastómero de acrilonitrilo-butadieno

La sigla NBR proviene de Nitrile Butadiene Rubber. NBR es el material utilizado con mayor frecuencia en la técnica de juntas a su buena resistencia contra la mayoría de aceites y grasas con base de aceite mineral. El rango de utilización térmica se encuentra normalmente entre -30 °C y +100 °C, durante períodos breves hasta +130 °C; a temperaturas más elevadas se endurece el material. Además, NBR presenta un favorable comportamiento respecto al envejecimiento y un rozamiento reducido.

NBR es resistente a los aceites hidráulicos, glicoles de agua y aceite en emulsiones acuosas, aceites minerales y productos derivados de los mismos, aceites animales y vegetales, gasolina, gasóleo de calefacción, agua hasta unos +70 °C, butano, propano, metano, etano. NBR es fuertemente expansivo en presencia de hidrocarburos aromáticos, por ejemplo, benzol, hidrocarburos clorados (por ejemplo, tricloroetileno), ésteres, disolventes polares como acetona, así como líquidos de frenos sobre base de éteres glicólicos.

NBR – LT

NBR-LT (Low Temperature) posee las mismas resistencias y propiedades que NBR en un rango de aplicación térmica de -50 °C a +100 °C.

Einleitung zur Beständigkeitstabelle

Im Sinne der Zuverlässigkeit und Langlebigkeit von EXMAR Produkten erfordert der Umgang mit flüssigen oder gasförmigen Fluiden eine hohe Sorgfalt bei der Auswahl der Werkstoffe, die mit den Fluiden in Kontakt kommen. Dieses gilt insbesondere für aggressive Fluide. Die nachfolgende Tabelle zur chemischen Beständigkeit von Elastomeren, Kunststoffen und Metallen für eine Vielzahl gasförmiger und flüssiger Medien soll die Auswahl geeigneter Materialien beim Einsatz von EXMAR Produkten erleichtern.

Die chemische Beständigkeit der bei EXMAR verwendeten Werkstoffe ist abhängig von vielen Faktoren. Hierzu gehören u.a. die Temperatur des Mediums, der Verschmutzungsgrad des Mediums, Beimengungen unerwünschter Begleitstoffe (z.B. Wasserspuren in gasförmigem SO₂), die Konzentration des Mediums, die gleichzeitige Einwirkung mechanischer Kräfte wie statische oder dynamische Belastung sowie die Konstruktionsmerkmale des Produktes.

All diese Faktoren beeinflussen in der Praxis z.B. das Korrosionsverhalten der metallischen sowie die chemische Beständigkeit der polymeren Werkstoffe. Die in den Beständigkeitstabellen getroffenen Angaben können daher nicht alle Betriebsbedingungen und Anwendungsfälle, wie sie im praktischen Gebrauch von EXMAR Produkten auftreten, berücksichtigen.

Daher stellen die in den Beständigkeitstabellen gemachten Angaben lediglich Empfehlungen dar, für die wir jedoch keine Haftung übernehmen können. Aus den Angaben können weder Gewährleistungsansprüche noch Garantieforderungen abgeleitet werden. Die einsatzspezifische Auswahl der Werkstoffe, die Anwendung, Verwendung und Verarbeitung der bezogenen Produkte liegen ausschliesslich im Verantwortungsbereich des Kunden/Anwenders. Es empfiehlt sich im Zweifelsfall, unsere Produkte – u.U. auch mit unterschiedlichen Werkstoffkombinationen – versuchsweise einzubauen, um deren Verhalten bei realen Betriebsbedingungen prüfen zu können.

Introduction to the resistance table

For the optimal reliability and durability of EXMAR products in applications with liquid or gaseous media, it is essential to exercise extreme care when selecting the materials that come into contact with the media. This is especially true for aggressive liquids. The following table on the chemical resistance of elastomers, plastics and metals to numerous gaseous and liquid media is intended to assist EXMAR customers in the selection of suitable materials for their applications.

The chemical resistance of materials used by EXMAR depends on many factors, such as the temperature of the medium, the degree of contamination of the medium, the admixture of unwanted impurities (e.g. traces of water in gaseous SO₂), the concentration of the medium, the simultaneous effect of mechanical forces, e.g. static or dynamic stress, as well as the design characteristics of the product.

In practice, all these factors can influence, for example, the corrosion behaviour, the metallic and chemical resistance of polymer materials. The data contained in the chemical resistance tables cannot, therefore, cover all the working conditions and applications which you will meet in your daily use of EXMAR products.

For this reason, the information given in the chemical resistance tables should only be considered recommendations for which we assume no liability. No warranty claims or guarantees can be inferred from this information. The application-specific selection of materials, use, implementation and processing of purchased products lies solely within the scope of responsibility of the customer/user. If there is any doubt, we recommend installing our products - if indicated, in a variety of material combinations - in test installations to be able to determine their behaviour under real operating conditions.

Introducción a la tabla de resistencias

Con respecto a la fiabilidad y duración de los productos EXMAR, el manejo de fluidos líquidos o gaseosos exige extremar las precauciones en la elección de los materiales que entrarán en contacto con los fluidos. Esto es aplicable especialmente a los fluidos agresivos. La siguiente tabla contiene la resistencia química de elastómeros, plásticos y metales respecto a numerosos medios fluidos y gaseosos y pretende facilitar la elección de los materiales adecuados a la hora de utilizar productos EXMAR.

La resistencia química de los materiales utilizados en EXMAR depende de muchos factores. Esto incluye, entre otros, la temperatura del medio, el grado de suciedad del medio, mezclas de sustancias acompañantes no deseadas (p. ej., trazas de agua en SO₂ gaseoso), la concentración del medio, la acción simultánea de fuerzas mecánicas como cargas estáticas o dinámicas, y las características constructivas del producto.

En la práctica, todos estos factores influyen, p. ej., en la resistencia a la corrosión de los metales y la resistencia química de los polímeros. Por tanto, los datos que figuran en las tablas de resistencias no pueden tener en cuenta todas las condiciones de servicio y todos los casos de aplicación relacionados con la utilización práctica de productos EXMAR.

En consecuencia, los datos contenidos en las tablas de resistencias representan solamente recomendaciones de las que, sin embargo, no podemos responsabilizarnos. Del mismo modo, no pueden deducirse reclamaciones o derechos de garantía de los datos ofrecidos. La selección de los materiales en función de la finalidad, así como la aplicación, utilización y procesamiento de los productos adquiridos son responsabilidad exclusiva del cliente/usuario. En caso de duda, se recomienda montar nuestros productos y probar, en su caso, diferentes combinaciones de materiales para poder ensayar su comportamiento en condiciones de servicio reales.

Aufbau und Inhalt der Beständigkeitstabellen

Die Beständigkeitstabelle umfasst drei Bereiche chemischer Flüssigkeiten und Gase. Diese sind Grundchemikalien, Handelsprodukte sowie Lebensmittel. In einzelnen wurde die Beständigkeit dieser Fluide auf bei EXMAR häufig eingesetzte elastomere Werkstoffe, Kunststoffe sowie Metalle und Legierungen klassifiziert. Informationen zu der chemischen Beständigkeit der in den Beständigkeitstabellen nicht aufgeführten Materialien sind auf Anfrage erhältlich.

Für die gebräuchlichsten chemischen Substanzen findet sich in den Tabellen zum besseren Verständnis eine chemische Formel (Linienformel). Mit dem Zusatz „rein“ hinter der chemischen Bezeichnung des Mediums ist technische Reinheit gemeint, die in den meisten Fällen weit über 95% Wirkstoffgehalt liegt. In der Regel tragen organische flüssige oder gasförmige Substanzen diesen Zusatz. So bedeutet z.B. „Essigsäure - rein“, dass es sich um mindestens 98%-ige Essigsäure handelt. Der Zusatz „wässrig“ wird meistens in Verbindung von mit Wasser mischbaren Substanzen (z.B. Ethanol) oder aber für wässrige Lösungen anorganischer Salze verwendet. Wegen der Vielzahl verschiedener möglicher Konzentrationen werden generell mittlere Konzentrationen angenommen. Nur wenn es ausdrücklich vermerkt ist, handelt es sich dabei um gesättigte wässrige Lösungen.

Die Bezugstemperatur für die jeweils angegebene chemische Beständigkeit ist in jedem Falle Raumtemperatur. Bei höheren Temperaturen muss bei Kunststoffen und Elastomeren mit einer wärmebedingt schlechteren Beständigkeit gerechnet werden.

Zeichenerklärung

- + geringe oder keine Beeinträchtigung des Materials, beständig
- o schwacher bis mässiger Angriff, bedingt beständig
- starker Angriff bis vollständige Zerstörung, unbeständig

Bei der Einstufung eines Materials als bedingt beständig ist vor allem die Zeit der Einwirkung zu berücksichtigen. Bei langer Einwirkungsdauer kann es häufig zu einem starken Angriff bzw. zur vollständigen Zerstörung des Materials kommen. Dieses wirkt sich dann u.U. auf die Einsatzdauer der verwendeten Teile aus. Aus diesem Grunde sind diese Teile auch als Verschleißteile einzustufen, für die hinsichtlich des möglichen Verschleißes keine Garantie übernommen werden kann.

Häufig können aufgrund unterschiedlicher Betriebsbedingungen keine eindeutigen Angaben gemacht werden. Auch in diesem Falle wird das Zeichen "o" verwendet für bedingt beständig.

Quellennachweis

Sämtliche Angaben der Beständigkeitstabellen stützen sich auf Erfahrungswerte der Industrie und auf Daten der Werkstoffhersteller (Quellen: www.buerkert.ch, www.buerkle.de).

Layout and content of the resistance table

The resistance table comprises three types of chemical liquids and gases: basic chemicals, trade products as well as foodstuffs. Specifically, the resistance of these fluids has been classified for the elastomer materials, plastics, metals and alloys frequently used in EXMAR products. Information on the chemical resistance of materials not listed in the tables is available on request.

A chemical formula for the most common substances has been included in the tables. The word „pure“ added to the chemical denomination of the medium refers to technical purity, which in most cases exceeds an active substance content of 95%. Organic liquid or gaseous substances generally bear this term. So, for example, „acetic acid - pure“ means that this is at least a 98% acetic acid. The word „aqueous“ is usually used in combination with substances that are miscible with water (e.g. ethanol) or for aqueous solutions of inorganic salts as well. Due to the diversity of the different concentrations possible, average concentrations are generally assumed. Only when it is explicitly mentioned does it concern a saturated aqueous solution.

The reference temperature for the respective chemical resistance indicated is always room temperature. At elevated temperatures, a poorer heat-related resistance must be expected for plastics and elastomers.

Signs and symbols

- + little or no damage to the material, resistant
- o slight to moderate attack, conditionally resistant
- strong attack to complete destruction, not resistant

If a material is classified as conditionally resistant, the amount of exposure time must be taken into account. For longer periods of exposure, the intensity of the attack is often greater, often resulting in complete destruction of the material. This can under certain circumstances have an effect on the service life of the respective part. This is why these parts are categorised as wearing parts, for which no guarantee can be given regarding the possibility of wear and tear.

Explicit statements are frequently not possible due to the varying operating conditions. In such cases, the "o" symbol for conditionally resistant is also used.

References

All the information contained in the resistance tables is based on empirical values of industry and on the data from material manufacturers (sources: www.buerkert.ch, www.buerkle.de).

Estructura y contenido de las tablas de resistencias

La tabla de resistencias engloba tres sectores de líquidos y gases químicos, a saber: sustancias químicas básicas, productos comerciales y alimentos. Se ha clasificado específicamente la resistencia a estos fluidos de los materiales elastoméricos, plásticos, metales y aleaciones más utilizados en EXMAR. La información sobre la resistencia química de los materiales que no aparecen en las tablas puede enviarse a petición del cliente.

Las tablas contienen una fórmula química (fórmula lineal) de las sustancias químicas más usuales para su mejor comprensión. El suplemento "puro" después de la denominación química del medio se refiere a la pureza técnica, que en la mayoría de los casos se sitúa muy por encima del 95% en contenido de principio activo. Generalmente llevan este suplemento las sustancias orgánicas líquidas o gaseosas. La expresión "ácido acético puro" significa, por ejemplo, que se trata por lo menos de ácido acético al 98%. El suplemento "acuoso" se utiliza sobre todo para sustancias miscibles con agua (p. ej., etanol) o para soluciones acuosas de sales inorgánicas. Debido a la infinidad de diferentes concentraciones posibles, se suponen generalmente concentraciones medias. Solamente si se hace mención expresa, se trata de soluciones acuosas saturadas.

La temperatura de referencia para la resistencia química indicada en cada caso es siempre la temperatura ambiente. Con temperaturas más altas cabe esperar una reducción de la resistencia de los plásticos y elastómeros por efecto del calor.

Explicación de los símbolos

- + poca o nula influencia en el material, resistente
- o ataque débil a moderado, resistencia condicionada
- ataque intenso a destrucción total, no resistente

A la hora de clasificar un material como de resistencia condicionada debe tenerse en cuenta sobre todo el tiempo de actuación. Con tiempos de actuación largos no es infrecuente que se produzca un ataque intenso o la destrucción completa del material y que esto repercuta en el periodo de uso de las piezas utilizadas. Por esta razón, las piezas utilizadas deben clasificarse también como piezas de desgaste para las que no se aceptan garantías debido precisamente al posible desgaste.

Las diferencias en las condiciones de servicio a menudo impiden emitir datos inequívocos, en cuyo caso se utiliza también el carácter "o" para designar "resistencia condicionada".

Índice de fuentes

Todos los datos de las tablas de resistencias se basan en valores empíricos de la industria y en datos de los fabricantes de los materiales (fuentes: www.buerkert.ch, www.buerkle.de).

Chemikalien- beständigkeit	Resistance to chemicals	Resistencia a sustancias químicas		FKM	EPDM	PTFE	FFKM	PEEK	POM	NBR	PU	LD-PE	1.4401/1.4571	1.4305/1.4104
Abgase - fluorwasserstoffhaltig	Waste gases - containing hydrogen fluoride	Gases de escape que contienen fluoruro de hidrógeno		+	+	+	+	-		+	+	o	o	
Abgase - kohlendioxidhaltig	Waste gases - containing carbon dioxide	Gases de escape que contienen dióxido de carbono		+	+	+	+	+		+	+	+	+	o
Abgase - kohlenmonoxidhaltig	Waste gases - containing carbon monoxide	Gases de escape que contienen monóxido de carbono		+	+	+	+	+		+	+	+	+	+
Abgase - nitroserhaltig	Waste gases - containing nitrous gases	Gases de escape que contienen compuestos nitrosos		+	+	+	+	+		o		+	+	+
Abgase - salzsäurehaltig	Waste gases - containing hydrochloric acid	Gases de escape que contienen ácido clorhídrico		+	+	+	+	o		+		+	o	-
Abgase - schwefeldioxidhaltig (trocken)	Waste gases - containing sulphur dioxide (dry)	Gases de escape que contienen dióxido de azufre (seco)		+	+	+	+	+		o		+	+	+
Abgase - schwefelsäurehaltig - (Schwefeltrioxid feucht)	Waste gases - containing sulphuric acid - (sulphur trioxide moist)	Gases de escape que contienen ácido sulfúrico (trioxido de azufre húmedo)		+	+	+	+	-		o		+	+	o
Abgase - schwefeltrioxidhaltig (trocken)	Waste gases - containing sulphur trioxide (dry)	Gases de escape que contienen trióxido de azufre (seco)		+	+	+	+	+		o		+	+	+
Acetaldehyd - rein	Acetaldehyde - pure	Acetaldehído puro	CH ₃ CHO	o	+	+	+	+	+	-	+	o	+	+
Acetessigester (säurefrei, rein)	Ethyl acetoacetate (acid-free, pure)	Éster acetoacético (libre de ácidos, puro)	CH ₃ COCH ₂ CO ₂ C ₂ H ₅	-	-	+	+			-			+	+
Aceton - rein	Acetone - pure	Acetona - pura	CH ₃ COCH ₃	-	+	+	+	+	+	-	-	o	+	+
Acetophenon - rein	Acetophenone - pure	Acetofenona - pura	C ₆ H ₅ COCH ₃	-		+	+		+	-		+	+	+
Acetylaceton - rein	Acetyl acetone - pure	Acetilacetona - pura	CH ₃ COCH ₂ COCH ₃	-	-	+	+			-			+	+
Acetylchlorid - rein	Acetyl chloride - pure	Acetil cloruro - puro	CH ₃ COCl	-	-	+	+		-	-		+	o	o
Acetylen - rein	Acetylene - pure	Acetileno - puro	HCCH	-	+	+	+	+	+	-	+	+	+	+
Acronaldispersionen (Polyacrylsäureester für Klebstoffe)	Acronal dispersion (polyacrylate for adhesives)	Dispersiones Acronal (éster del ácido poliacrílico para adhesivos)		+	+	+				-			+	+
Acronallösungen	Acronal solutions	Soluciones Acronal		-	o	+				-			+	+
Acrylnitril - rein	Acrylonitrile - pure	Acrlonitrilo - puro	CH ₂ CHCN	-	-	+	+	+		-	-	o	+	+
Acrylsäureethylester - rein	Ethyl acrylate - pure	Éster etílico del ácido acrílico - puro	CH ₂ CHCOOC ₂ H ₅	-	o	+	+			-	-		+	+
Adipinsäure - wässrig	Adipic acid - aqueous	Ácido adipínico - acuoso	HO ₂ C(CH ₂) ₄ CO ₂ H	+	+	+	+		+	+		+	+	+
Akkusäure (20 %-ige Schwefelsäure, wässrig)	Battery acid (20 % sulphuric acid, aqueous)	Ácido de batería (ácido sulfúrico 20 %, acuoso)	H ₂ SO ₄	+	+	+	+	o	-	o		+	+	o
Alaun (KaliumAluminiumsulfat) - wässrig	Alum (potassium aluminium sulphate) - aqueous	Alumbre (sulfato de aluminio y potasio) acuoso	KAl(SO ₄) ₂ * 12H ₂ O	+	+	+	+	+	o	+	+	+	+	o
Albumin - rein	Albumin - pure	Albúmina - pura		+	+	+				+			+	+
Allylalkohol - rein	Allyl alcohol - pure	Alcohol alílico - puro	CH ₂ CHCH ₂ OH	-	+	+	+	+		+		-	+	+
Aluminiumacetat - wässrig	Aluminium acetate - aqueous	Acetato de aluminio - acuoso	Al(OOCCH ₃) ₃	+	+	+	+		+	o		+	+	+
Aluminiumchlorid - wässrig	Aluminium chloride - aqueous	Cloruro de aluminio - acuoso	AlCl ₃	+	+	+	+	+	-	+	o	+	o	o
Aluminiumfluorid - wässrig	Aluminium fluoride - aqueous	Fluoruro de aluminio - acuoso	AlF ₃	+	+	+	+		o	+		+	-	-
Aluminiumsulfat - wässrig	Aluminium sulphate - aqueous	Sulfato de aluminio - acuoso	Al ₂ (SO ₄) ₃	+	+	+	+	+	o	+		+	o	o
Ameisensäure - rein	Formic acid - pure	Ácido fórmico - puro	HCO ₂ H	-	o	+	o	o	-	-	-	+	+	-
Ameisensäure - wässrig	Formic acid - aqueous	Ácido fórmico - acuoso	HCO ₂ H	-	o	+	-	+	o	-	-	+	+	o
Aminoessigsäure (Glykokoll)	Amino acetic acid (glycocol)	Ácido aminoacético (glicocol)	NH ₂ CH ₂ COOH	+	+	+			+	o		+	+	+
Ammoniak (flüssig) - rein	Ammonia (liquid) - pure	Amoniaco (líquido) - puro	NH ₃	-	2o	+	o	+	+	-	-	+	+	+
Ammoniak (gasförmig) - rein	Ammonia (gaseous) - pure	Amoniaco (gaseoso) - puro	NH ₃	-	+	+	o	+	+	-	-	+	+	+
Ammoniak-Wasser (Salmiakgeist)	Ammonium hydroxide (spirits of ammonia)	Amoniaco-agua (solución acuosa de amoniaco)	NH ₄ OH	-	+	+	o	+	+	-	-	+	+	+
Ammoniumacetat - wässrig	Ammonium acetate - aqueous	Acetato de amonio - acuoso	CH ₃ COONH ₄	+	+	+	+			+		+	+	+
Ammoniumcarbonat - wässrig	Ammonium carbonate - aqueous	Carbonato de amonio - acuoso	(NH ₄) ₂ CO ₃	+	+	+	+			+	-	+	+	+
Ammoniumchlorid - wässrig	Ammonium chloride - aqueous	Cloruro de amonio - acuoso	NH ₄ Cl	+	+	+	+	+	+	+	-	+	o	o
Ammoniumcitrat - wässrig	Ammonium citrate - aqueous	Citrato de amonio - acuoso		+	+	+	+			+			+	+
Ammoniumfluorsilikat - wässrig	Ammonium fluosilicate - aqueous	Fluorosilicato de amonio - acuoso		+	+	+	+			+			+	+
Ammoniumfluorid - wässrig	Ammonium fluoride - aqueous	Fluoruro de amonio - acuoso	NH ₄ F	+	+	+	o			+		+	o	o
Ammoniumformiat - wässrig	Ammonium formate - aqueous	Formiato de amonio - acuoso	HNCOONH ₄	+	+	+	+			+			+	+
Ammoniumnitrat - wässrig	Ammonium nitrate - aqueous	Nitrato de amonio - acuoso	NH ₄ NO ₃	+	+	+	+	+		+	+	+	+	+
Ammoniumoxalat - wässrig	Ammonium oxalate - aqueous	Oxalato de amonio - acuoso	NH ₄ O ₂ CCO ₂ NH ₄	+	+	+	+			+		+	+	+
Ammoniumpersulfat - wässrig	Ammonium persulphate - aqueous	Persulfato de amonio - acuoso	(NH ₄) ₂ S ₂ O ₈	+	+	+	+			-	+	+	o	o
Ammoniumphosphat - wässrig	Ammonium phosphate - aqueous	Fosfato de amonio - acuoso	(NH ₄) ₂ HPO ₄	+	+	+	+			+	+	+	+	+
Ammoniumthiocyanat - wässrig	Ammonium thiocyanate - aqueous	Tiocianato de amonio - acuoso	NH ₄ NCS	+	+	+			+	+		+		
Ammoniumsulfat - wässrig	Ammonium sulphate - aqueous	Sulfato de amonio - acuoso	(NH ₄) ₂ SO ₄	+	+	+	+	+	+	+	+	+	o	o
Ammoniumsulfid - wässrig	Ammonium sulphide - aqueous	Sulfuro de amonio - acuoso	(NH ₄) ₂ S	o	+	+	+			+		+	+	+
Ammoniumsulfit - wässrig	Ammonium sulphite - aqueous	Sulfito de amonio - acuoso	(NH ₄) ₂ SO ₃	+	+	+	+			+			+	o
Amylacetat - rein	Amyl acetate - pure	Acetato de amilo - puro	CH ₃ COO(CH ₂) ₄ CH ₃	-	o	+	+	+		-	-	o	+	+
Amylalkohol - rein	Amyl alcohol - pure	Alcohol amílico - puro	H ₃ C(CH ₂) ₄ OH	+	o	+	+			+	+	+	+	+
Ananassaft	Pineapple juice	Zumo de piña				+						+	+	+
Anilin - rein	Aniline - pure	Anilina - pura	C ₆ H ₅ NH ₂	o	+	+	o	+	+	-	-	o	+	+
Anilinhydrochlorid - wässrig	Aniline hydrochloride - aqueous	Clorhidrato de anilina - acuoso	C ₆ H ₅ NH ₃ Cl	3o	+	+	+			o		-	-	
Anisöl	Anis seed oil	Aceite de anís				+				o			+	+
Anisöl - rein	Anis seed oil - pure	Anisöl - puro	C ₆ H ₅ OCH ₃	-	o	+	+			o	-	-	+	+
Anon (Cyclohexanon) - rein	Anon (cyclohexanone) - pure	Anona (ciclohexanona) - pura	C ₆ H ₁₀ O	-	-	+	+	+		-	-	-	+	+
Anthracenöl - rein	Anthracene oil - pure	Aceite de antraceno - puro		-	-	+	+			-			+	+

Chemikalien- beständigkeit	Resistance to chemicals	Resistencia a sustancias químicas		FKM	EPDM	PTFE	FFKM	PEEK	POM	NBR	PU	LD-PE	1.4401/1.4571	1.4305/1.4104
Anthrachinonsulfonsäure - wässrig	Anthraquinone sulphonic acid - aqueous	Ácido sulfónico antraquinono - acuoso	$C_6H_4COCOC_6H_4SO_3H$	+	+	+	+			o			o	o
Antifrogen-N	Antifrogen-N	Antifrogen-N		+	+	+				+			+	+
Antimonchlorid - wässrig	Antimony chloride - aqueous	Cloruro de antimonio - acuoso	$SbCl_3$	3+	+	+	+	+		o	+	+	-	-
Apfelsaft, Apfelsmus	Apple juice, Applesauce	Zumo de manzana, puré de manzana				+		+				+	+	+
Apfelsäure - wässrig	Malic acid - aqueous	Ácido málico - acuoso	$(HO)CH(COOH)CH_2COOH$	+	+	+	+			+	o		+	+
Apfelsinensaft	Orange juice	Zumo de naranja				+						+		+
Apfelwein	Cider	Sidra		+	+	+				+			+	+
Aprikosensaft	Apricot juice	Zumo de albaricoque				+							+	+
Arabinsäure - wässrig	Arabic acid - aqueous	Ácido arábico - acuoso		+	+	+	+			+			+	+
Argon - rein	Argon - pure	Argón - puro	Ar	+	+	+	+	+		+	+		+	+
Arsenige Säure - wässrig	Arsenious acid - aqueous	Ácido arsenioso - acuoso	$H_3AsO_3 (As_2O_3+H_2O)$	+	+	+	+			-	+	o	+	+
Arsensäure - wässrig	Arsenic acid - aqueous	Ácido arsénico - acuoso	H_3AsO_4	+	+	+	+			-	+	o	+	+
Arsenichlorid - wässrig	Arsenic trichloride - aqueous	Tricloruro de arsénico - acuoso	$AsCl_3$	+	+	+	+			+			o	o
Arylsilikate - wässrig	Aryl silicates - aqueous	Aryl silicatos - acuosos		o	o	+	+			o			+	+
Ascorbinsäure - wässrig	Ascorbic acid - aqueous	Ácido ascórbico - acuoso		+	+	+	+			+		+		
Asparginsäure - wässrig	Aspartic acid - aqueous	Ácido aspártico - acuoso	$(HOOC)CH(NH_2)CH_2COOH$	+	+	+	+			+			+	+
ASTM-Kraftstoff A	ASTM fuel A	Combustible ASTM A		o	-	+	+			o			+	+
ASTM-Kraftstoff B	ASTM fuel B	Combustible ASTM B		o	-	+	+			o			+	+
ASTM-Kraftstoff C	ASTM fuel C	Combustible ASTM C		o	-	+	+			o			+	+
ASTM-Öl Nr. 1	ASTM oil no. 1	Aceite ASTM n.º 1		+	-	+	+			+			+	+
ASTM-Öl Nr. 2	ASTM oil no. 2	Aceite ASTM n.º 2		+	-	+	+			o			+	+
ASTM-Öl Nr. 3	ASTM oil no. 3	Aceite ASTM n.º 3		o	-	+	+			o			+	+
ATE-Bremsflüssigkeit	ATE brake fluid	Líquido de frenos ATE		-	+	+	+	+		-			+	+
Ätherische Öle	Essential oils	Aceites esenciales		-	-	+	+			-		-	+	+
Bariumchlorat - wässrig	Cottonseed oil	Clorato de bario - acuoso	$Ba(ClO_3)_2$	+	+	+	+			+			+	+
Bariumchlorid - wässrig	Barium chloride - aqueous	Cloruro de bario - acuoso	$BaCl_2$	+	+	+	+	+		+	+	+	+	o
Bariumhydroxid - wässrig	Barium hydroxide - aqueous	Hidróxido de bario - acuoso	$Ba(OH)_2$	+	+	+	+			+	+	+	+	+
Bariumsulfid und -polysulfid, wässrig	Barium sulphide and polysulphide, aqueous	Sulfuro y polisulfuro de bario, acuoso	BaS	+	+	+	+	+		+	+	+	+	+
Baumwollsaamenöl	Cottonseed oil	Aceite de semillas de algodón		o	-	+	+			o			+	+
Benzaldehyd - wässrig	Benzaldehyde - aqueous	Benzaldehído - acuoso	C_6H_5CHO	+	+	+	+	+	+	o	o	o	+	+
Benzidinsulfonsäuren - wässrig	Benzidine sulphonic acids - aqueous	Ácidos bencidin sulfónicos - acuosos	$(NH_2)_2C_6H_4C_6H_4(SO_3H)(NH_2)$	+	+	+	+			+			+	+
Benzin (Hexan) - rein	Gasoline (hexane) - pure	Gasolina (hexano) - pura	C_6H_{14}	+	-	+	+	+	+	o		-	+	+
Benzin-Benzol-Spiritus - (Superkraftstoff-Methanol-Gemisch)	Gasoline-benzene alcohol (premium gasoline/methanol mixture)	Gasolina-benceno-alcohol - (mezcla de combustible súper/metanol)		o	-	+	+	+		-			+	+
Benzoessäure - wässrig	Benzoic acid - aqueous	Ácido benzoico - acuoso	C_6H_5COOH	+	+	+	+	+	+	+		-	+	+
Benzol - rein	Benzene - pure	Benceno - puro	C_6H_6	+	-	+	+	+	+	+		-	o	+
Benzolsulfonsäure - wässrig	Benzene sulphonic acid - aqueous	Ácido benceno sulfónico - acuoso	$C_6H_5SO_3H$	+	+	+	+	-		+		+	+	+
Benzylalkohol - rein	Benzyl alcohol - pure	Alcohol bencílico - puro	$C_6H_5CH_2OH$	o	+	+	+	+	+	-	-	-	+	+
Benzylbutylphthalat - wässrig	Benzyl butyl phthalate - aqueous	Ftalato de bencil-butilo - acuoso		-	-	+	+			-			+	+
Bergamottöl	Bergamot oil	Aceite de bergamota		-	-	+	+			-			+	+
Bernsteinsäure - wässrig	Succinic acid - aqueous	Ácido succínico - acuoso	$HOOCCH_2CH_2COOH$	+	+	+	+			o	+		+	+
Bienenwachs	Beeswax	Cera de abejas		+	+	+				+	+		+	+
Bier	Beer	Cerveza		+	+	+				+	+		+	+
Bisulfit (Natriumbisulfit) - wässrig	bisulphite (sodium hydrogen sulphite) - aqueous	Bisulfito (bisulfito de sodio) - acuoso	$NaHSO_3$	o	+	+	+	+		o			+	o
Blausäure - wässrig	Hydrocyanic acid - aqueous	Ácido cianhídrico - acuoso	HCN	+	o	+	+			-	o	+	+	o
Bleiacetat - wässrig	Lead acetate - aqueous	Acetato de plomo - acuoso	$Pb(CH_3COO)_2$	+	+	+	+	+	+	o	+	+	+	+
Bleichlauge (Natriumhypochlorit)	Bleaching lye (sodium hypochlorite)	Agente blanqueante (hipoclorito de sodio)		o	+	+	+	+		-	-	o	o	o
Bleinitrat - wässrig	Lead nitrate - aqueous	Nitrato de plomo - acuoso	$Pb(NO_3)_2$	+	+	+	+			+			+	+
Bleitetraethyl (Tetraethylblei) - rein	Lead tetraethyl (tetraethyl lead) - pure	Tetraetilo de plomo (plomo tetraetilo) - puro	$Pb(CH_2CH_3)_4$	+	o	+	+			o			+	+
Bohröle (Schneidöle)	Drilling oils (cutting oils)	Aceites de perforación (aceites de corte)		o	-	+	+			o			+	+
Borax - wässrig	Borax - aqueous	Bórax - acuoso	$Na_2B_4O_7$	+	+	+	+			+	+		+	+
Borfluorwasserstoffsäure (Fluorborssäure)	Borofluoric acid (fluoboric acid)	Ácido borofluorhídrico (ácido fluorobórico)	$HFbF_4$	+	+	+	o			+	-		-	-
Borsäure - wässrig	Boric acid - aqueous	Ácido bórico - acuoso	H_3BO_3	+	+	+	+	o	+	+	+	+	+	+
Bremsflüssigkeit (ATE-Bremsflüssigkeiten)	Braking fluid (ATE braking fluids)	Líquido de frenos (líquidos de frenos ATE)		-	+	+	+	+		-			+	+
Brom (flüssig) - rein	Bromine (liquid) - pure	Bromo (líquido) - puro	Br_2	-	-	+	+	-	-	-	-	o	o	o
Bromwasserstoffsäure (wässrig)	Hydrobromic acid - aqueous	Ácido bromhídrico (acuoso)	HBr	+	+	+	+	-	-	-	-	o	-	-
Butadien (gasförmig) - rein	Butadiene (gaseous) - pure	Butadieno (gaseoso) - puro	$CH_2=CHCH=CH_2$	o	o	+	+			o	o	-	+	+
Butan (gasförmig und flüssig)	Butane (gaseous and liquid)	Butano (gaseoso o líquido)	C_4H_{10}	+	-	+	+	+	+	+	+	+	+	+
Butandiol - wässrig (10 %)	Butylene ether glycol - aqueous (10 %)	Butanodiol - acuoso (10 %)	$HO(CH_2)_4OH$	o	+	+	o	+	+	+			+	+
Butanol (Butylalkohol) - rein	Butanol (butyl alcohol) - pure	Butanol (alcohol butílico) - puro	C_4H_9OH	+	+	+	+	+	+	o	o	o	+	+
Butindiol - rein	Butyne diol - pure	Butinodiol - puro	$HOCH_2C_2CH_2OH$	o	o	+	+			o			o	+

Chemikalien- beständigkeit	Resistance to chemicals	Resistencia a sustancias químicas		FKM	EPDM	PTFE	FFKM	PEEK	POM	NBR	PU	LD-PE	1.4401/1.4571	1.4305/1.4104
Butoxyl (Methoxybutylacetat) - rein	Butoxyl (methoxybutyl acetate) - pure	Butoxilo (acetato de metoxibutila) - puro	$\text{CH}_3\text{OC}_4\text{H}_9\text{O}_2\text{CCH}_3$	o	o	+				+			+	+
Butter	Butter	Mantequilla		+	+	+				+	+	+	+	+
Buttermilch	Buttermilk	Suero de mantequilla		+	+	+				+			+	+
Buttersäure - wässrig	Butyric acid - aqueous	Ácido butírico - acuoso	$\text{H}_3\text{CCH}_2\text{CH}_2\text{COOH}$	o	o	+	o	+	-	o	-	-	+	o
Butylacetat - rein	Butyl acetate - pure	Acetato de butilo - puro	$\text{CH}_3(\text{CH}_2)_3\text{O}_2\text{CCH}_3$	-	+	+	+	+		-	-		+	+
Butylalkohol (Butanol) - rein	Butyl alcohol (butanol) - pure	Alcohol butílico (butanol) - puro	$\text{CH}_3(\text{CH}_2)_3\text{OH}$	+	+	+	+	+		o	o	o	+	+
Butylen (flüssig) - rein	Butylene (liquid) - pure	Butileno (líquido) - puro	$\text{H}_2\text{CCH}_2\text{CHCH}_2$	+	o	+	+			+	+		+	+
Butylphthalat - rein	Butyl phthalate - pure	Ftalato de butilo - puro	$\text{C}_6\text{H}_4(\text{CO})_2(\text{OCH}_2\text{CH}_2\text{CH}_2\text{CH}_2\text{O})_2$	-	-	+	+			-			+	+
Calciumbisulfit - wässrig	Calcium bisulphite - aqueous	Bisulfito de calcio - acuoso	$\text{Ca}(\text{HSO}_3)_2$	+	+	+	+	+	-	+	o	+	+	o
Calciumchlorid - wässrig	Calcium chloride - aqueous	Cloruro de calcio - acuoso	CaCl_2	+	+	+	+	+		+	+	+	o	o
Calciumhydroxid (Kalkmilch) - wässrig	Calcium hydroxide (lime-milk) - aqueous	Hidróxido de calcio (lechada de cal) - acuoso	$\text{Ca}(\text{OH})_2$	+	+	+	+	+	+	+	o	+	+	+
Calciumhypochlorit (Chlorkalk) - wässrig	Calcium hypochlorite (chlorinated lime) - aqueous	Hipoclorito de calcio (cloruro de cal) - acuoso	$\text{Ca}(\text{OCl})_2$	o	+	+	+	+	+	-	-	+	o	o
Calciumnitrat - wässrig	Calcium nitrate - aqueous	Nitrato de calcio - acuoso	$\text{Ca}(\text{NO}_3)_2$	+	+	+	+	+		+	+	+	o	o
Carbolinum (Teeröl, Pflanzenschutzmittel)	Carbolinum (creosote; pesticide)	Carbolino (creosota, plaguicidas)		o	o	+	+		+	o		+	+	+
Carbolsäure (Phenol) - wässrig	Carbolic acid (phenol) - aqueous	Ácido carbólico (fenol) - acuoso	$\text{C}_6\text{H}_5\text{OH}$	o	o	+	+	+		o	-	+	+	+
Caro'sche Säure - wässrig	Caro's acid - aqueous	Ácido de Caro - acuoso	H_2SO_5	-	-	+				-			-	-
Cellosolve (Glykoethylether) - rein	Cellosolve (glycol ethyl ether) - pure	Cellosolve (etil glicol éter) - puro	$\text{HO}(\text{CH}_2)_2\text{OCH}_2\text{CH}_3$	-	-	+	+		+	-	-		+	+
Celluloselacke	Cellulose lacquers	Pinturas celulósicas		-	o	+	+			-			+	+
Champheröl - rein	Camphor oil - pure	Aceite de alcanfor - puro		+	-	+	o			+			+	+
Chlophene (Chlordiphenyl)	Chlophene (chlorobiphenyl)	Clófeno (clorodifenilo)		+	o	+				+			+	+
Chlor (flüssig) - rein	Chlorine (liquid) - pure	Cloro (líquido) - puro	Cl_2	o	-	+	+	-	-	-	-	-	+	+
Chlor (gasförmig) - feucht (Chlorwasser)	Chlorine (gaseous) - wet (chlorine water)	Cloro (gaseoso) - húmedo (agua de cloro)	Cl_2	o	-	+	o	-	-	-	-	-	-	-
Chlor (gasförmig) - trocken	Chlorine (gaseous) - dry	Cloro (gaseoso) - seco	Cl_2	o	-	+	+	+		-	-	-	+	-
Chloralhydrat (Chloral) - wässrig	Chloral hydrate (chloral) - aqueous	Hidrato de cloral (cloral) - acuoso	$\text{CCl}_3\text{CH}(\text{OH})_2$	o	o	+	+			-	-	o	o	o
Chlorbenzole - rein	Chlorobenzene - pure	Clorobenceno - puro	$\text{C}_6\text{H}_5\text{Cl}$	-	-	+	+	+	+	-	o	-	+	+
Chlorbleichlauge (Natriumhypochlorit) - wässrig	Sodium hypochlorite bleach - aqueous	Lejía de cloro blanqueante (hipoclorito de sodio) - acuosa	NaOCl	o	+	+	+	+	-	-		o	o	o
Chlordioxid - wässrig	Chlorine dioxide - aqueous	Dióxido de cloro - acuoso	ClO_2	-	-	+	o			-	-		o	o
Chloressigsäure - wässrig	Chloroacetic acid - aqueous	Ácido cloroacético - acuoso	ClCH_2COOH	-	o	+	+	+	-	-	-	o	o	-
Chlorethanol (Ethylenchlorhydrin) - rein	Chloroethanol (ethylene chlorohydrine) - pure	Cloroetanol (clorhidrina de etileno) - puro	$\text{ClCH}_2\text{CH}_2\text{OH}$	o	-	+	+		o	-			+	+
Chlorkalk (Calciumhypochlorit) - wässrig	Chlorinated lime (calcium hypochlorite) - aqueous	Cloruro de cal (hipoclorito de calcio) - acuoso	$\text{Ca}(\text{OCl})_2$	o	+	+	+	+	-	-	-	+	o	o
Chlormethan (Methylchlorid) - rein	Chloromethane (methyl chloride) - pure	Clorometano (cloruro de metilo) - puro	ClCH_3	o	-	+	+		+	-	-	o	+	+
Chlornaphthalin - rein	Chloronaphthaline - pure	Cloronaftalina - pura	$\text{C}_{10}\text{H}_7\text{Cl}$	o	-	+	+			-			+	+
Chloroform (Trichlormethan) - rein	Chloroform (trichloromethane) - pure	Cloroformo (triclorometano) - puro	CHCl_3	o	-	+	+	+	-	-	-	-	+	+
Chlorphenole - rein	Chlorophenol - pure	Clorofenol - puro	$\text{C}_6\text{H}_4(\text{OH})(\text{Cl})$	-	-	+	+			-			+	+
Chlorphenoxyessigsäure	Chlorophenoxyacetic acid - pure	Ácido clorofenoxiacético	$(\text{OC}_6\text{H}_4)_2\text{CHCOOH}$	+	+	+				+			+	+
Chlorsäure - wässrig	Chloric acid - aqueous	Ácido clórico - acuoso	HClO_3	-	o	+	+			-	-	+	-	-
Chlorsulfonsäure - rein	Chlorosulphonic acid - pure	Ácido clorosulfónico - puro	ClSO_3H	-	-	+	+	-	-	-	-	-	o	o
Chlorwasser (Chlor - feucht)	Chlorine water (chlorine - wet)	Agua de cloro (cloro - húmedo)	Cl_2	o	-	+	o	-	-	-	-	-	-	-
Chlorwasserstoffgas - rein	Hydrogen chloride gas - pure	Cloruro de hidrógeno - puro	HCl	+	o	+	+	+	-	o			+	o
Chlorxylenol - rein	Chlorxylenol - pure	Cloroxileno - puro	$\text{C}_6\text{H}_2(\text{OH})(\text{CH}_3)_2(\text{Cl})$	-	-	+	+			-			+	+
Cholinchlorid - wässrig	Choline chloride - aqueous	Cloruro de colina - acuoso	$[\text{HOCH}_2\text{CH}_2\text{N}(\text{CH}_3)_3]\text{Cl}$	+	+	o	+			+				
Chromalaun - wässrig	Chrome alum - aqueous	Alumbre de cromo - acuosa	$\text{KCr}(\text{SO}_4)_2 \cdot 12\text{H}_2\text{O}$	+	+	+	+			+			o	o
Chromsäure - wässrig	Chromic acid - aqueous	Ácido crómico - acuoso	H_2CrO_4	+	o	+	+	o	-	-	-	+	o	o
Chromsulfat - wässrig	Chromous sulfate - aqueous	Sulfato de cromo - acuoso	$\text{Cr}_2(\text{SO}_4)_3$	+	+	+	+			+			o	o
Citral (Citronellöl) - rein	Citral (citronella oil) - pure	Citral (esencia de citronela) - puro		-	-	+				-			+	+
Cyanalkali (Kaliumcyanid) - wässrig	Potassium cyanide - aqueous	Cianuro potásico - acuoso	KCN	+	+	+	+	+	o	+	o	+	+	+
Cyclanone (Fettalkoholsulfonat)	Cyclanone (fatty alcohol sulphonate)	Cyclanone (sulfonato de alcohol graso)		+	+	+				+	+		+	+
Cyclohexan - rein	Cyclohexane - pure	Ciclohexano - puro	C_6H_{12}	o	-	+	+	+	+	-	-	-	+	+
Cyclohexanol - rein	Cyclohexanol - pure	Ciclohexanol - puro	$\text{C}_6\text{H}_{11}\text{OH}$	+	-	+	+	+	+	-	-	+	+	+
Cyclohexanon (Anon) - rein	Cyclohexanon (Anon) - pure	Ciclohexanona (anon) - pura	$\text{C}_6\text{H}_{10}\text{O}$	-	-	+	+	+	+	-	-	-	+	+
Cymol - rein	Cymene - pure	Cimeno - puro	$\text{C}_6\text{H}_4(\text{CH}_3)[\text{CH}(\text{CH}_3)_2]$	-	-	+				-			+	+
Dekahydronaphthalin (Dekalin) - rein	Decahydronaphthalene (decalin) - pure	Decahidronaftalina (decalina) - pura	$\text{C}_{10}\text{H}_{18}$	+	-	+				-			+	+
Desmodur T	Desmodur T	Desmodur T		+	+	+				+			+	+
Desmophen	Desmophen	Desmophen		+	+	+				+			+	+
Dextrin - wässrig	Dextrin - aqueous	Dextrina - acuosa		+	+	+	+			+	+		+	+
Dextrose (Glukose) - wässrig	Dextrose (glucose) - aqueous	Dextrosa (glucosa) - acuosa	$\text{C}_6\text{H}_{12}\text{O}_6$	+	+	+	+	+	+	+	+	+	+	+
Diacetonalkohol (wasserfrei) - rein	Diacetone alcohol (anhydrous) - pure	Diacetona alcohol anhidro - puro	$(\text{CH}_3)_2\text{C}(\text{OH})\text{CH}_2\text{COCH}_3$	-	+	+	+			+	-	+	+	+
Dibutylphthalat - rein	Dibutyl phthalate - pure	Ftalato de dibutilo - puro	$\text{C}_6\text{H}_4(\text{COOC}_4\text{H}_9)_2$	-	o	+	+			+	-	o	+	+

Chemikalien- beständigkeit	Resistance to chemicals	Resistencia a sustancias químicas		FKM	EPDM	PTFE	FFKM	PEEK	POM	NBR	PU	LD-PE	1.4401/1.4571	1.4305/1.4104
Dibutylsebacat - rein	Dibutylsebacat - pure	Sebacato de dibutilo - puro	(C ₄ H ₉ COO)(CH ₂) ₈ (OOC ₄ H ₉)	-	o	+	+					o	+	+
Dichlorethan (Ethylenchlorid) - rein	Dichloroethane (ethyl dichloride) - pure	Dicloroetano (cloruro de etileno) - puro	ClCH ₂ CH ₂ Cl	-	-	+	+	+	+	-	-	-	+	-
Dichlorethylen - rein	Dichloroethylene - pure	Dicloroetileno - puro	Cl ₂ CHCH ₃	o	-	+	+	+	-	-	-	-	+	+
Dichlormethan (Methylenchlorid) - rein	Dichloromethane (methylene chloride) - pure	Diclorometano (cloruro de metileno) - puro	CH ₂ Cl ₂	o	-	+	+	o	o	-	-	-	+	+
Dicyclohexylammoniumnitrit - rein	Dicyclohexyl ammonium nitrite - pure	Nitrito de dicitlohexilamonio - puro	[(C ₆ H ₁₁) ₂ NH ₂]NO ₂	+	+	+	+			+			+	+
Dieselöl - rein	Diesel oil - pure	Gasóleo - puro		+	-	+	+	+	+	o		o	+	+
Diethylether (Ether) - rein	Diethyl ether (ether) - pure	Éter dietílico (éter) - puro	CH ₃ CH ₂ OCH ₂ CH ₃	-	-	+	+	+	+	-		-	+	+
Dimethylamin - rein	Dimethylamine - pure	Dimetilamina - puro	(CH ₃) ₂ NH	-	o	+	+			-		o	+	+
Dimethylformamid (DMF) - rein	Dimethylformamide (DMF) - pure	Dimetilformamida (DMF) - pura	HCON(CH ₃) ₂	-	-	+	+	+	+	-	o	+	+	+
Dimethylsulfoxid (DMSO) - rein	Dimethylsulfoxide (DMSO) - pure	Dimetil sulfóxido (DMSO) - puro	(CH ₃) ₂ SO			+	+	o	+		+	-		
Diocetylphthalat (DOP) - rein	Diocetylphthalate (DOP) - pure	Ftalato de dioctilo (DOP) - puro	C ₈ H ₄ (COOC ₈ H ₁₇) ₂	o	o	+	+			-	-	o	+	+
Dioxan - rein	Dioxan - pure	Dioxano - puro	C ₄ H ₈ O ₂	-	o	+	+		+	-	+	-	+	+
Diphenyl + Diphenyloxid	Diphenyl + diphenyl oxide	Bifenilo + óxido de bifenilo		-	-	+	+		+	-	-	+	+	+
Dissousgas (Acetylen + Aceton)	Dissolved acetylene (acetylene + acetone)	Acetileno disuelto (acetileno + acetona)		-	+	+				-			+	+
Distickstoffmonoxyd (Lachgas, Stickoxydul)	Nitrogen monoxide (laughing gas, nitrous oxide)	Monóxido de dinitrógeno (gas hilarante, óxido nitroso)	N ₂ O	+	+	+	+	+		+	+		+	+
Edelgase	Inert gases	Gases nobles		+	+	+	+	+		+			o	+
Eisenchlorid - wässrig	Ferrous chloride - aqueous	Cloruro de hierro - acuoso	FeCl ₃	+	+	+	+	+		+	o	+	-	-
Eisensulfat - wässrig	Iron sulphate - aqueous	Sulfato de hierro - acuoso	FeSO ₄	+	+	+	+	+		+	+	+	+	+
Eiweißlösungen	Protein solutions	Soluciones proteicas		+	+	+				+			+	+
Erdgas	Natural gas	Gas natural		+	-	+	+	+	+	o			+	+
Essig (Weinessig)	Vinegar (wine vinegar)	Vinagre (de vino)		+	+	+	+	+	+	+		o	+	+
Essigester (Ethylacetat) - rein	Acetic ether (ethyl acetate) - pure	Éster acético (etilacetato) - puro	CH ₃ CO ₂ CH ₂ CH ₃	-	o	+	o	+	+	-		-	+	+
Essigsäure - rein	Acetic acid - pure	Ácido acético - puro	CH ₃ COOH	-	o	+	o	+	-	-	-	o	+	-
Essigsäureanhydrid - rein	Acetic anhydride - pure	Anhidrido acético - puro	CH ₃ COOCOCH ₃	-	o	+	o			-		-	o	o
Ethan - rein	Ethane - pure	Etano - puro	CH ₃ CH ₃	+	-	+	+	+		+			+	+
Ethanol (Ethylalkohol) - rein	Ethanol (ethyl alcohol) - pure	Etanol (alcohol etílico) - puro	CH ₃ CH ₂ OH	o	+	+	+	+	+	o		+	+	+
Ethanolamin - rein	Ethanolamine - pure	Etanolamina - pura	NH ₂ CH ₂ CH ₂ OH	-	o	+	+			o			+	+
Ether (Diethylether) - rein	Ether (diethyl ether) - pure	Éter (éter dietílico) - puro	CH ₃ CH ₂ OCH ₂ CH ₃	-	-	+	+	+	+	-		-	+	+
Ethylacetat (Essigester) - rein	Ethyl acetate (acetic ether) - pure	Acetato de etilo (éter acético) - puro	CH ₃ CO ₂ CH ₂ CH ₃	-	o	+	o	+	+	-		-	+	+
Ethylalkohol - Gärungsmaische	Ethyl alcohol - fermentation slurry	Alcohol etílico - caldo de fermentación		+	+	+	+	+	+	+			+	+
Ethylalkohol - vergällt (Spiritus)	Ethyl alcohol - denatured (spirit)	Alcohol etílico - desnaturalizado (espíritu)		o	o	+	+	+		o			+	+
Ethylalkohol (Ethanol) - rein	Ethyl alcohol (ethanol) - pure	Alcohol etílico (etanol) - puro	CH ₃ CH ₂ OH	o	+	+	+	+	+	o		+	+	+
Ethylalkohol + Essigsäure	Ethyl alcohol + acetic acid	Alcohol etílico + ácido acético	CH ₃ CH ₂ OH + CH ₃ COOH	o	+	+	+	+		o			+	+
Ethylbenzol - rein	Ethyl benzene - pure	Etilbenceno - puro	C ₆ H ₅ CH ₂ CH ₃	o	-	+	+		+	-		-	+	+
Ethylchlorid - rein	Ethyl choride - pure	Cloruro etílico - puro	CH ₃ CH ₂ Cl	+	+	+	+		+	+		-	+	+
Ethylen - rein	Ethylene - pure	Etileno - puro	CH ₂ CH ₂	+	-	+	+	+	+	+			+	+
Ethylenbromid - wasserfrei	Ethylene bromide - anhydrous	Bromuro de etileno - anhidro	CH ₂ CHBr	-	-	+	+	-		-		-	+	+
Ethylenchlorhydrin (Chlorethanol) - rein	Ethylene chlorhydrine (chloroethanol) - pure	Clorhidrina de etileno (cloroetanol) - pura	ClCH ₂ CH ₂ OH	o	-	+	+	o	o	-			+	+
Ethylenchlorid (Dichlorethan) - rein	Ethylene dichloride (dichloroethane) - pure	Cloruro de etileno (dicloroetano) - puro	ClCH ₂ CH ₂ Cl	-	-	+	+	+	+	-		-	+	-
Ethylendiamin - rein	Ethylene diamine - pure	Etilendiamina - pura	NH ₂ CH ₂ CH ₂ NH ₂	o	+	+	o		+	o		o	+	o
Ethylenglykol (Glykol) - rein	Ethylene glycol (glycol) - pure	Etilenglicol (glicol) - puro	HOCH ₂ CH ₂ OH	+	+	+	+	+	+	+			+	+
Ethylenoxid (flüssig) - rein	Ethylene oxide (liquid) - pure	Óxido de etileno (líquido) - puro	CH ₂ CH ₂ O	-	-	+	o		+	-		o	+	+
Ethylformiat	Ethyl formate	Formiato de etilo	HCOOCH ₂ CH ₃	-	o	+	+			-			+	+
Färbereinetzmittel (Nekal BX)	Dyeing surfactant (Nekal BX)	Tensoactivo de tintorerías (Nekal BX)		+	+	+				+			+	+
Ferricyankalium (Kaliumferricyanid)	Potassium ferricyanide	Ferricianuro potásico	KFeCN ₄	+	+	+	+		+	+		+	+	+
Fettalkohole	Fatty alcohols	Alcoholes grasos		+	o	+	+			+			+	o
Fettalkoholsulfate (sulfatierte Fette) - wässrig	Fatty alcohol sulphates (sulphated fats) - aqueous	Alcoholes grasos sulfatados (grasas sulfatadas) - acuosos		+	o	+	+		+	+			+	+
Fette, fette Öle	Fats, fatty oils	Grasas, aceites grasos		o	-	+	+	+	+	o		+	+	+
Fichtennadelöl	Pine needle oil	Aceite de agujas de picea		+	-	+	+			o		-	+	+
Firnisse	Oil varnishes	Barnices		+	-	+	+			o			+	+
Fluor (feucht) - rein	Fluorine (wet) - pure	Flúor (húmedo) - puro	F ₂	-	-	o	-	-	-	-		-	o	o
Fluor (trocken) - rein	Fluorine (dry) - pure	Flúor (seco) - puro	F ₂	o	-	o	o	-	-	-		-	+	+
Fluorborssäure (Borfluorwasserstoffsäure)	Fluoboric acid (borofluoric acid)	Ácido fluorobórico (ácido borofluorhidrico)	HF ₄	+	+	+	o			+	-		-	-
Fluorkohlenstoffe (Frigen)	Fluorocarbons (Frigen)	Fluorocarburos (Freón 12)				+	+					-		
Flusssäure - wässrig	Hydrofluoric acid - aqueous	Ácido fluorhídrico - acuoso	HF	-	-	o	-	-	-	-	+		o	-
Formaldehyd - rein	Formaldehyde - pure	Formaldehido - puro	CH ₂ O	o	o	+	+	+	+	o			+	+
Formaldehyd - wässrig	Formaldehyde - aqueous	Formaldehido - acuoso	CH ₂ O	o	o	+	+	o	+	o	+	+	+	+
Formamid - rein	Formamide - pure	Formamida - pura	HCONH ₂	o	+	+	o		+	+		+	+	o

Chemikalien- beständigkeit	Resistance to chemicals	Resistencia a sustancias químicas		FKM	EPDM	PTFE	FFKM	PEEK	POM	NBR	PU	LD-PE	1.4401/1.4571	1.4305/1.4104
Foto - Emulsionen, Entwickler, Fixierbäder	Photo emulsions, developers, fixing baths	Fotografía - emulsiones, agentes reveladores, baños de fijación		o	o	+	+		+	o		+		
Freon TF (Freon 113)	Freon TF (Freon 113)	Freón TF (Freón 113)	Cl ₃ CClF ₃	-	-	+	-	+	+	+			+	+
Freon 12 B1 (Freon 12 B1)	Freon 12 B1 (Freon 12 B1)	Freón 12 B1 (Freón 12 B1)	CBrClF ₂	o	-	+	+	+		+		-	+	+
Frigen 13	Frigen 13	Frigen 13	CClF ₃	o	-	+	o	+		+			+	+
Frigen 13 B 1 (Halon 1301)	Frigen 13 B 1 (Halon 1301)	Frigen 13 B 1 (Halon 1301)	CBrF ₃	o	-	+	+			+			+	+
Frigen 22	Frigen 22	Frigen 22	CHClF ₂	-	-	+	o	+	+	-		-	+	+
Frigen 23	Frigen 23	Frigen 23	CHF ₃	o	-	+	-			+		-	+	+
Frigen 502	Frigen 502	Frigen 502	C ₆ H ₁₂ O	-	-	+	o	+		-			+	+
Frigenersatz HFCKW 123	Frigen substitute HCFC 123	Sustituto de Frigen HCFC 123		-	-	+	-	+		-			+	+
Frigenersatz HFCKW 134a	Frigen substitute HCFC 134a	Sustituto de Frigen HCFC 134a		-		+	-	+					+	+
Frostschutzmittel KFZ	Anti-freeze for automobiles	Anticongelante para automóviles		+	+	+	+	+	+	o		+		
Fruchtsäfte	Fruit juices	Zumos de fruta		o	o	+		+	+	o		+	+	+
Gaswasser	Gas water	Agua amoniacal		o	-	+				+			+	+
Gelatine - wässrig	Gelatine - aqueous	Gelatina - acuosa		+	+	+	+	+	+	+		+	+	+
Gerbsäure (Tannin)	Tannic acid (tannin)	Ácido tánico (tanino)		+	+	+	+			-	+	o	+	+
Glukose (Traubenzucker) - wässrig	Glucose (dextrose) - aqueous	Glucosa (azúcar de uvas) - acuosa	C ₆ H ₁₂ O ₆	+	+	+	+	+	+	+	+	+	+	+
Glykokoll (Aminosäure) - wässrig	Glycine (aminoacetic acid) - aqueous	Glicocola (ácido aminoacético) - acuosa	NH ₂ CH ₂ CHCO ₂ H	+	+	+			+	o		+	+	+
Glykol - wässrig	Glycol - aqueous	Glicol - acuoso	HOCH ₂ CH ₂ OH	+	+	+	+	+	+	+		+	+	+
Glykolether (Cellosolve)	Glycol ethyl ether (Cellosolve)	Etil glicol éter (celosolve)	HO(CH ₂) ₂ OCH ₂ CH ₃	-	-	+	+		+	-		-	+	+
Glykolsäure - wässrig	Gycolic acid - aqueous	Ácido glicólico - acuoso	HOCH ₂ COOH	+	+	+	+			+			o	o
Glyzerin - rein	Glycerine - pure	Glicerina - pura	HOCH ₂ CH(OH)CH ₂ OH	+	+	+	+	+		o		+	+	o
Glyzerin - wässrig	Glycerine - aqueous	Glicerina - acuosa	HOCH ₂ CH(OH)CH ₂ OH	+	+	+	+	+		+	+	+	+	o
Grubengas (Methan)	Mine gas (methane)	Gas de mina (metano)	CH ₄	+	-	+	+	+		+	o		+	+
Haarschampoo	Hair shampoo	Champú		o	o	+				o			+	+
Harnstoff - wässrig	Urea - aqueous	Urea - acuosa	NH ₂ CONH ₂	+	+	+	+	+	+	+	+	+	o	o
Hefe - wässrig	Yeast - aqueous	Levadura - acuosa		+	+	+	+	+	+	+		+	+	+
Heizöle	Fuel oils	Gasóleos de calefacción		+	-	+	+		+	o		-	+	+
Helium	Helium	Helio	He	+	+	+	+	+	+	+	+	+	+	+
Heptane, Hexan (Benzin) - rein	Heptane, hexane (gasoline) - pure	Heptano, hexano (gasolina) - pura		+	-	+	+	+	+	+	+	-	+	+
Hexamethylentetramin - wässrig	Hexamethylene tetramine - aqueous	Hexametilentetramina - acuosa		+	+	+	+			+			+	+
Holzteer, Holzöl (Imprägnieröle)	Tar, wood oil (waterproofing oils)	Brea, aceite de madera (aceites de impregnación)		-	-	+	+			-	+		+	+
Huminsäuren	Humic acids	Ácidos húmicos		+	+	+				+			+	+
Hydraulikfl. (Wasser in Öl, HSB)	Hydraulic fluid, water-in-oil (HSB)	Líquido hidráulico (agua en aceite, HSB)		+	-	+	+			o			+	+
Hydraulikfl. Mineralöle (H, H-L, H-LP)	Hydraulic fluid, mineral oils (H, H-L, H-LP)	Líquido hidráulico, aceites minerales (H, H-L, H-LP)		o	-	+	+			o			+	+
Hydraulikfl. Phosphorsäureester (HSD)	Hydraulic fluid, phosphoric ester (HSD)	Líquido hidráulico, éster de ácido fosfórico (HSD)		o	o	+	+			-			+	+
Hydraulikfl. Polyglykol-Wasser (HSC)	Hydraulic fluid, polyglycol-water (HSC)	Líquido hidráulico, poliglicol-agua (HSC)		+	+	+	+			+			+	+
Hydraulikfl. Wasser-Öl-Emulsionen (HSA)	Hydraulic fluid, oil-in-water emulsions (HSA)	Líquido hidráulico, emulsiones agua-aceite (HSA)		+	-	+	+			o			+	+
Hydrazinhydrat - wässrig	Diamide hydrate - aqueous	Hidrato de hidracina - acuoso	NH ₂ NH ₂ * 2 H ₂ O	+	+	+	+	+	+	-	-	+	-	o
Hydrochinon - wässrig	Hydroquinone - aqueous	Hidroquinona - acuosa	C ₆ H ₄ (OH) ₂	+	+	+	+					+	+	o
Hydroxylaminsulfat - wässrig	Hydroxylamine sulphate - aqueous	Sulfato de hidroxilamina - acuoso	(NH ₂ OH) ₂ SO ₄	+	+	+	+			+		+	+	+
Imprägnieröle (Holzteer)	Waterproofing oils (tar)	Aceites de impregnación (brea)		-	-	+	+			-	+	+	+	+
Isobutanol - rein	Isobutanol - pure	Isobutanol - puro	(CH ₃) ₂ CHCH ₂ OH	+	+	+	+	+	+	o	-	+	+	+
Isooctan - rein	Isooctane - pure	Isooctano - puro	CH ₃ C(CH ₃) ₂ CH ₂ CH(CH ₃)CH ₃	+	-	+	+	+	+	+	+	o	+	+
Isopropanol (Propanol) - rein	Isopropyl alcohol (propanol) - pure	Isopropanol (propanol) - puro	CH ₃ CH(OH)CH ₃	+	+	+	+	+	+	o	o	+	+	+
Jod + Jodkalium - wässrig	Iodine + potassium iodide - aqueous	Iodo + yoduro potásico - acuoso	I ₂ + KI	o	o	+	+	o	+	o		+	o	o
Jodinktur	Iodine tincture	Tintura de yodo		o	o	+	+	o	+	o		o	o	o
Kalilauge (Kaliumhydroxid) - wässrig	Caustic potash solution (potassium hydroxide) - aqueous	Potasa cáustica (hidróxido de potasio) - acuosa	KOH	-	+	+	+	+	+	-	+	+	+	+
Kalium-Aluminiumsulfat (Alaun) - wässrig	Aluminium potassium sulphate (alum) - aqueous	Sulfato aluminico potásico (alumbre) - acuoso	KAl(SO ₄) ₂ * 12 H ₂ O	+	+	+	+	+	o	+	+	+	+	o
Kaliumbromat - wässrig	Potassium bromate - aqueous	Bromato de potasio - acuoso	KBrO ₃	+	+	+	+			+			+	o
Kaliumbromid - wässrig	Potassium bromide - aqueous	Bromuro de potasio - acuoso	KBr	+	+	+	+	+	+	+	+	+	+	o
Kaliumcarbonat (Pottasche) - wässrig	Potassium carbonate (potash) - aqueous	Carbonato de potasio (potasa) - acuoso	K ₂ CO ₃	+	+	+	+	+	+	+	o	+	+	+
Kaliumchlorat - wässrig	Potassium chlorate - aqueous	Clorato de potasio - acuoso	KClO ₃	o	o	+	+	+	+	o	+		o	o
Kaliumchlorid - wässrig	Potassium chloride - aqueous	Cloruro de potasio - acuoso	KCl	+	+	+	+	+	+	+	+	+	+	o
Kaliumchromat - wässrig	Potassium chromate - aqueous	Cromato de potasio - acuoso	K ₂ CrO ₄	o	+	+	+			o		+	o	o
Kaliumcyanid - wässrig	Potassium cyanide - aqueous	Cianuro de potasio - acuoso	KCN	+	+	+	+	+	+	o	+	o	+	+
Kaliumdichromat - wässrig	Potassium dichromate - aqueous	Dicromato de potasio - acuoso	K ₂ Cr ₂ O ₇	o	o	+	+	+	o	o	+	+	+	+

Chemikalien- beständigkeit	Resistance to chemicals	Resistencia a sustancias químicas		FKM	EPDM	PTFE	FFKM	PEEK	POM	NBR	PU	LD-PE	1.4401/1.4571	1.4305/1.4104
Kaliumferrocyanid (Kaliumcyanoferrat III) - (rotes Blutlaugesalz) (Ferricyankalium), - wässrig	Potassium ferrocyanide, (tripotassium hexacyanoferrate III) - red prussiate of potash - aqueous	Ferricianuro de potasio (cianoferrato de potasio III) - (prusiato rojo) (ferricianuro potásico), - acuoso	KFeCN ₄	+	+	+	+	+	+	+		+	+	+
Kaliumferrocyanid (Kaliumcyanoferrat II) - (rotes Blutlaugesalz) (Ferricyankalium) - wässrig	Potassium ferrocyanide (potassium cyanoferrate II) - yellow prussiate of potash - aqueous	Ferrocianuro de potasio (cianoferrato de potasio II) - (prusiato amarillo) (ferricianuro potásico) - acuoso	KFeCN ₃	+	+	+	+	+	+	+		+	o	-
Kaliumhydrogenfluorid - wässrig	Potassium hydrogen fluoride - aqueous	Fluoruro de potasio hidrógeno - acuoso	KHF ₂	+	+	+				+				+
Kaliumhydroxid (Kalilauge) - wässrig	Potassium hydroxide (caustic potash) - aqueous	Hidróxido de potasio (potasa cáustica) - acuosa	KOH	-	+	+	+	+	o	-	+	+	+	+
Kaliumhypochlorit - wässrig	Potassium hypochlorite - aqueous	Hipoclorito de potasio - acuoso	KOCl	o	+	+	+	+	-	-	-	o	o	o
Kaliumjodid - wässrig	Potassium iodide - aqueous	Ioduro de potasio - acuoso	KI	+	+	+	+		+	+		+	o	o
Kaliumnitrat - wässrig	Potassium nitrate - aqueous	Nitrato de potasio - acuoso	KNO ₃	+	+	+	+	+	+	+	+	+	o	o
Kaliumnitrit - wässrig	Potassium nitrite - aqueous	Nitrito de potasio - acuoso	KNO ₂	+	+	+	+	+		+				+
Kaliumpermanganat - wässrig	Potassium permanganate - aqueous	Permanganato de potasio - acuoso	KMnO ₄	-	-	+	+	+	+	-		+	+	o
Kaliumperoxid - wässrig	Potassium peroxide - aqueous	Peróxido de potasio - acuoso	K ₂ O ₂	-	-	+	+	+		-				+
Kaliumpersulfat - wässrig	Potassium persulphate - aqueous	Persulfato de potasio - acuoso	K ₂ S ₂ O ₈	o	+	+	+	+		-		+	+	+
Kaliumphosphate - wässrig	Potassium phosphate - aqueous	Fosfato de potasio - acuoso		+	+	+	+	+		+				+
Kaliumsulfat - wässrig	Potassium sulphate - aqueous	Sulfato de potasio - acuoso	K ₂ SO ₄	+	+	+	+	+	+	+		+	+	+
Kaliumsulfid - wässrig	Potassium sulphide - aqueous	Sulfuro de potasio - acuoso	K ₂ S	+	+	+	+	+		+		+	+	+
Kaliumsulfit - wässrig	Potassium sulphite - aqueous	Sulfito de potasio - acuoso	K ₂ SO ₃	+	+	+	+	+	+	+	+	+	+	o
Kerosin (Petroleumbenzin; Benzin)	Kerosene (petroleum benzene, gasoline)	Keroseno (gasolina de petróleo; gasolina)		+	-	+	+	+	+	+	+	+	-	+
Kiefernadelöl (Fichtennadelöl)	Pine needle oil	Aceite de aguja de pino (aceite de aguja de picea)		+	-	+	+			o		-	+	+
Kieselfluorwasserstoffsäure (Kieselflussäure) - wässrig	Hydrofluosilicic acid (silicofluoric acid) - aqueous	Ácido fluorosilícico (ácido silícico) - acuoso		o	o	+	+		-	o	-	+	o	o
Knochenöl	Bone oil	Aceite de hueso		+	-	+	+			o				+
Kochsalz (Natriumchlorid)	Salt (sodium chloride)	Sal de cocina (cloruro de sodio)		+	+	+	+	+	+	+		+	o	o
Kochsalz (Natriumchlorid) - wässrig	Salt (sodium chloride) - aqueous	Sal de cocina (cloruro de sodio) - acuosa	NaCl	+	+	+	+	+	+	+	+	+	o	o
Kohlendioxid - feucht	Carbon dioxide - wet	Dióxido de carbono - húmedo	CO ₂	+	+	+	+	+	+	+	+	+	+	+
Kohlendioxid - trocken	Carbon dioxide - dry	Dióxido de carbono - seco	CO ₂	+	+	+	+	+	+	+	+	+	+	+
Kohlenmonoxid (Kohlenoxid)	Carbon monoxide (carbon oxide)	Monóxido de carbono (óxido de carbono)	CO	+	+	+	+	+		+	+			+
Kohlensäure - wässrig	Carbonic acid - wet	Ácido carbónico - acuoso	H ₂ CO ₃	+	+	+	+	+	+	+	+	+	+	+
Kokosnussöl	Coconut oil	Aceite de coco		o	-	+	+	+		o		o	+	+
Königswasser	Aqua regia	Agua regia	HNO ₃ + HCl	-	-	+	+	-	-	-	-	-	-	-
Kresol - wässrig (s. Lysol)	Cresol - aqueous (see Lysol)	Cresol - acuoso (ver lisol)	C ₆ H ₄ (OH)(CH ₃)	o	-	+	+	+	-	-	-	+	o	o
Kupferacetat - wässrig	Acetate of copper - aqueous	Acetato de cobre - acuoso	Cu(CH ₃ COO) ₂	+	+	+	+	+		o		+	+	+
Kupferchlorid - wässrig	Copper chloride - aqueous	Cloruro de cobre - acuoso	CuCl ₂	+	+	+	+	+		+	+		-	-
Kupfersulfat - wässrig	Copper sulphate - aqueous	Sulfatos de cobre - acuosos	CuSO ₄	+	+	+	+	+	+	+	+		o	o
Lachgas (Distickstoffmonoxid, Stickoxydul)	Laughing gas (nitrogen monoxide, nitrous oxide)	Gas hilarante (monóxido de dinitrógeno, óxido nitroso)	N ₂ O	+	+	+	+	+		+	+			+
Lebensmittelfette und -öle	Food greases and oils	Grasas y aceites alimentarios		o	-	+	+	+	+	o				+
Lebertran	Cod liver oil	Aceite de hígado de bacalao		+	o	+	+			o		o	+	+
Leinöl	Linseed oil	Aceite de linaza		o	-	+	+	+	+	o		o	+	+
Leuchtgas (Stadtgas, Ferngas)	Coal gas (town gas, grid gas)	Gas de alumbrado (gas ciudad, gas a distancia)		+	+	+	+			+	o	+	+	+
Linolsäure	Linoleic acid	Ácido linoléico		o	-	+	+			o				+
Lithiumchlorid - wässrig	Lithium chloride - aqueous	Cloruro de litio - acuoso	LiCl	+	+	+	+			+			o	o
Lysol (siehe auch Kresole)	Lysol (see also cresol)	Lisol (véase también cresol)		o	-	+	+	+		-		-	+	o
Magnesiumchlorid - wässrig	Magnesium chloride - aqueous	Cloruro de magnesio - acuoso	MgCl ₂	+	+	+	+	+	+	+	+	+	o	o
Magnesiumsulfat - wässrig	Magnesium sulphate - aqueous	Sulfato de magnesio - acuoso	MgSO ₄	+	+	+	+	+	+	+	+	+	+	+
Maiskeimöl	Corn oil	Aceite de germen de maíz		o	-	+	+	+		o				+
Maleinsäure - wässrig	Maleic acid - aqueous	Ácido maleico - acuoso		+	+	+	+	+		+	-	+	+	o
Manganchlorid - wässrig	Manganese chloride - aqueous	Cloruro de manganeso - acuoso	MnCl ₂	+	+	+	+			+			o	o
Mangansulfat - wässrig	Manganese sulphate - aqueous	Sulfato de manganeso - acuoso	MnSO ₄	+	+	+	+			+				+
Maschinenöl siehe a) Paraffinöle b) Mineralöle; Motorenöle	Machine oil, see a) paraffin oils b) mineral oils; motor oils	Aceite para máquinas, véase a) aceites de parafina b) aceites minerales; aceites de motor		+	-	+	+	+	+	+		o	+	+
Melasse, Melassewürze	Molasses, molasses extract	Melaza, condimento de melaza		+	+	+	+	+	+	+	+	+	+	+
Mercaptane	Mercaptans	Mercaptanos		o	-	+	+			-				+
Mersole (Alkansulfonsäurechloride)	Mersol (alkane sulfochloride)	Mersoles (cloruros de ácido alcanosulfónico)		+	o	+				+			o	o
Methan (Sumpfgas) - rein	Methane (marsh gas) - pure	Metano (gas de los pantanos) - puro	CH ₄	+	-	+	+	+	+	+	o			+
Methanol (Methylalkohol)	Methanol (methyl alcohol)	Metanol (alcohol metílico)	CH ₃ OH	-	+	+	+	+	+	-	o	+	+	+
Methoxybutanol - rein	Methoxybutanol - pure	Metoxibutanol - puro	CH ₃ O(CH ₂) ₃ CH ₂ OH	+	+	+	+			+		o	+	+
Methylacetat - rein	Methyl acetate - pure	Metilacetato - puro	CH ₃ COOCH ₃	-	o	+	+	+	+	-		+	o	o
Methylalkohol (Methanol) - rein	Methyl alcohol (methanol) - pure	Alcohol metílico (metanol) - puro	CH ₃ OH	-	+	+	+	+	+	-	o	+	+	+
Methylamin - wässrig	Methylamine - aqueous	Metilamina - acuosa	CH ₃ NH ₂	o	o	+	-	+	+	-		o	o	o
Methylchlorid (Chlormethan) - rein	Methyl chloride (chloromethane) - pure	Cloruro de metilo (clorometano) - puro	CH ₃ Cl	+	-	+	+	+	+	-	-	o	+	+

Chemikalien- beständigkeit	Resistance to chemicals	Resistencia a sustancias químicas		FKM	EPDM	PTFE	FFKM	PEEK	POM	NBR	PU	LD-PE	1.4401/1.4571	1.4305/1.4104
Methylenchlorid (Dichlormethan) - rein	Methylene chloride (dichloromethane) - pure	Cloruro de metileno (diclorometano) - puro	CH ₂ Cl ₂	o	-	+	+	o	o	-	-	-	+	+
Methylethylketon - rein	Methyl ethyl ketone - pure	Metiletilcetona - pura	CH ₃ COCH ₂ CH ₃	-	o	+	+	o	+	-	-	-	+	+
Milch	Milk	Leche		+	+	+		+	+	+		+	+	+
Milchsäure - wässrig	Lactic acid - aqueous	Ácido láctico - acuoso		+	o	+	+	+	o	o	+	+	o	o
Mineralöle-aromatenfrei (Paraffinöl, Motorenöle)	Mineral oils - free of aromatic compounds (paraffin oils, motor oils)	Aceites minerales sin aromatizantes (aceite de parafina, aceites de motor)		+	-	+	+	+	+	+		o	+	+
Mineralwasser	Mineral water	Agua mineral		+	+	+		+	+	+		+	o	o
Morpholin - rein	Morpholine - pure	Morfolina - pura		o	o	+	o			-		+	+	+
Motorenöle (Mineralöle; Maschinenöle)	Motor oils (mineral oils, machine oils)	Aceites de motor (aceites minerales; aceites para máquinas)		+	-	+	+	+	+	+		o	+	+
Natriumarsenat und Natriumarsenit - rein	Sodium arsenate and sodium arsenite - pure	Arsenatos y arsenitos de sodio - puros	Na ₂ AsO ₄ u. Na ₃ AsO ₃	+	+	+	+			+			+	+
Natriumbenzoat - wässrig	Sodium benzoate - aqueous	Benzoato de sodio - acuoso	C ₆ H ₅ COONa	+	+	+	+		+	+		+	+	+
Natriumbicarbonat - wässrig	Sodium bicarbonate - aqueous	Bicarbonato de sodio - acuoso	NaHCO ₃	+	+	+	+	+	+	+		+	+	+
Natriumbisulfat - wässrig	Sodium bisulphate - aqueous	Bisulfato de sodio - acuoso	NaHSO ₄	+	+	+	+		+	+		+	o	o
Natriumbisulfit - wässrig (Bisulfit)	Sodium bisulphite - aqueous (bisulphite)	Bisulfito de sodio - acuoso (bisulfito)	NaHSO ₃	+	+	+	+	+	-	o		+	+	o
Natriumbromat - wässrig	Sodium bromate - aqueous	Bromato de sodio - acuoso	NaBrO ₃	+	+	+	+	+	+	+		+	o	o
Natriumbromid - wässrig	Sodium bromide - aqueous	Bromuro de sodio - acuoso	NaBr	+	+	+	+	+	+	+		+	o	o
Natriumcarbonat (Soda) - wässrig	Sodium carbonate (soda) - aqueous	Carbonato de sodio (soda) - acuoso	Na ₂ CO ₃	+	+	+	+	+	+	+		+	+	+
Natriumchloracetate	Sodium chloroacetate	Cloroacetato de sodio		+	+	+	+			+		+	+	+
Natriumchlorat - wässrig	Sodium chlorate - aqueous	Clorato de sodio - acuoso	NaClO ₃	o	o	+	+	+	+	o	+	+	o	o
Natriumchlorid (Kochsalz) - wässrig	Sodium chloride (salt) - aqueous	Cloruro de sodio (sal de cocina) - acuosa	NaCl	+	+	+	+	+	+	+	+	+	o	o
Natriumchlorit - wässrig	Sodium chlorite - aqueous	Cloruro de sodio - acuoso	NaClO ₂	o	o	+	+			-		o	o	-
Natriumchromat - wässrig	Sodium chromate - aqueous	Cromato de sodio - acuoso	NaCrO ₄	o	+	+	+	o		o		+	o	o
Natriumcyanid - wässrig	Sodium cyanide - aqueous	Cianuro de sodio - acuoso	NaCN	+	+	+	+	+	o	+	o	+	+	+
Natriumdodecylbenzolsulfonat - wässrig	Sodium dodecylbenzenesulfonate - aqueous	Dodecilsulfonato de sodio - acuoso		+	+	+				+	+	+	+	+
Natriumfluorid - wässrig	Sodium fluoride - aqueous	Fluoruro de sodio - acuoso	NaF	+	+	+	+		+	+	+	+	+	o
Natriumglutamat - wässrig	Monosodium glutamate - aqueous	Glutamato de sodio - acuoso		+	+	+	+			+			+	+
Natriumhydrogencarbonat - wässrig	Sodium bicarbonate - aqueous	Bicarbonato de sodio - acuoso	NaHCO ₃	+	+	+	+	+	+	+		+	+	+
Natriumhydroxid - wässrig	Sodium hydroxide - aqueous	Hidróxido de sodio - acuoso	NaOH	-	+	+	+	o		-	+	+	+	+
Natriumhypochlorit (Chlorbleichlauge) - wässrig	Sodium hypochlorite bleach - aqueous	Hipoclorito de sodio (lejía de cloro blanqueante) - acuosa	NaOCl	o	+	+	+	+	-	-		o	o	o
Natriumjodid - wässrig	Sodium iodide - aqueous	Ioduro de sodio - acuoso	NaI	+	+	+	+			+	+	+	o	o
Natriummercaptopbenzthiazol - rein	Sodium mercaptobenzothiazole - pure	Mercaptobenzotiazol de sodio - puro		+	o	+	+			o		+	+	+
Natriumnitrat - wässrig	Sodium nitrate - aqueous	Nitrato de sodio - acuoso	NaNO ₃	+	+	+	+	+	+	+	+	+	+	-
Natriumnitrit - wässrig	Sodium nitrite - aqueous	Nitrito de sodio - acuoso	NaNO ₂	+	+	+	+	+	+	+	+	+	+	+
Natriumpentachlorphenolat - rein	Sodium pentachlorophenolate - pure	Pentachlorofenolato de sodio - puro	C ₆ Cl ₅ ONa	+	+	+				+		+	+	+
Natriumperborat - wässrig	Sodium perborate - aqueous	Perborato de sodio - acuoso	NaBO ₃	+	+	+	+		+	o		+	+	+
Natriumpersulfat - wässrig	Sodium persulphate - aqueous	Persulfato de sodio - acuoso	K ₂ S ₂ O ₈	+	+	+	+			o		+	o	o
Natriumphosphat - wässrig	Sodium phosphate - aqueous	Fosfato de sodio - acuoso	Na ₃ PO ₄	+	+	+	+		+	+	+	+	o	o
Natriumpropionat - wässrig	Sodium propionate - aqueous	Propionato de sodio - acuoso	CH ₃ CH ₂ COONa	+	+	+				+		+	+	+
Natriumpyrosulfit - wässrig	Sodium metabisulphite - aqueous	Pirosulfito de sodio - acuoso	Na ₂ S ₂ O ₅	+	+	+			-	o	+	+	+	o
Natriumsilikate - wässrig	Sodium silicate - aqueous	Silicato de sodio - acuoso		+	+	+	+	+		+		+	+	+
Natriumstannat - wässrig	Sodium stannate - aqueous	Estanato de sodio - acuoso	Na ₂ SnO ₃	+	+	+	+			+			+	+
Natriumsulfat - wässrig	Sodium sulphate - aqueous	Sulfato de sodio - acuoso	Na ₂ SO ₄	+	+	+	+	+	+	+		+	+	+
Natriumsulfid - wässrig	Sodium sulphide - aqueous	Sulfuro de sodio - acuoso	Na ₂ S	+	+	+	+	+	+	+		+	+	+
Natriumsulfit - wässrig	Sodium sulphite - aqueous	Sulfito de sodio - acuoso	Na ₂ SO ₃	+	+	+	+	+	+	+		+	+	o
Natriumtartrat - wässrig	Sodium tartrate - aqueous	Tartrato de sodio - acuoso		+	+	+	+			+		+	+	+
Natriumthiosulfat - wässrig	Sodium thiosulphate - aqueous	Tiosulfato de sodio - acuoso	Na ₂ S ₂ O ₃	+	+	+	+		+	+		+	o	o
Natriumzinkat - wässrig	Sodium zincate - aqueous	Zincato de sodio - acuoso	Na ₂ [Zn(OH) ₄]	+	+	+				o			+	+
Natronlauge (Natriumhydroxid) - wässrig	Soda lye (sodium hydroxide) - aqueous	Sosa cáustica (hidróxido de sodio) - acuoso	NaOH	o	+	+	+	+	+	o	+	+	+	+
Nekal BX - wässrig (Färbereizmittel)	Nekal BX - aqueous (dyeing surfactant)	Nekal BX - acuoso (tensoactivo de tintorería)		+	+	+	o			+			+	+
Nickelbäder	Nickel baths	Baños de níquel		+	+	+				+			+	o
Nickelsulfat - wässrig	Nickel sulphate - aqueous	Sulfato de níquel - acuoso	Ni(SO ₄) ₂	+	+	+	+	+	+	+	+	+	+	o
Nitrobenzoesäuren - wässrig	Nitrobenzoic acids - aqueous	Ácidos de nitrobenzenceno - acuosos		+	+	+	+			+		o	+	+
Nitrobenzol - rein	Nitrobenzene - pure	Nitrobenzenceno - puro	C ₆ H ₅ NO ₂	o	-	+	+	o	o	-	-	-	+	+
Nitrose Gase - feucht und trocken	Nitrous fumes - wet and dry	Gases nitrosos - húmedos y secos	(NO, NO ₂ , N ₂ O ₄)	-	o	+	o	+	-	-			+	+
Nitrotoluole (o-, m-, p) - rein	Nitrotoluene (o-, m-, p) - pure	Nitrotolueno (o-, m-, p) - puro	C ₆ H ₄ (NO ₂)(CH ₃)	o	-	+	o	o	o	o		o	+	+
Oxalsäure - wässrig	Oxalic acid - aqueous	Ácido oxálico - acuoso	HOCCOOH	+	+	+	+	+	-	o			+	o
Obstbaum-Karbolinum (Karbolinum)	Fruit tree carbolineum (carbolineum)	Carbolíneo de árboles frutales (carbolíneo)		o	o	+	+			o	-	-	+	+
Oleum (rauchende Schwefelsäure)	Pyrosulfuric acid (fuming sulfuric acid)	Óleum (ácido sulfúrico fumante)	H ₂ SO ₄	o	-	+	+	-	-	-			+	o
Oliveöl	Olive oil	Aceite de oliva		o	-	+	+	+	+	o	-	+	+	+

Chemikalien- beständigkeit	Resistance to chemicals	Resistencia a sustancias químicas		FKM	EPDM	PTFE	FFKM	PEEK	POM	NBR	PU	LD-PE	1.4401/1.4571	1.4305/1.4104
4Ozon - feucht und trocken	4Ozone - wet and dry	4Ozono - húmedo y seco	O ₃	o	o	+	o	o	-	-	+	-	+	+
Paraffinöl (Mineralöle)	Paraffin oil (mineral oils)	Aceite de parafina (aceites minerales)		+	-	+	+	+	+	+	+	+	+	+
Perchlorethylen (Tetrachlorethylen) - rein	Perchloroethylene (tetrachloroethylene) - pure	Percloroetileno (tetracloroetileno) - puro	Cl ₂ CCl ₂	o	-	+	o	+	+	-	-	-	+	+
Peressigsäure - wässrig (6 %)	Peracetic acid - aqueous (6 %)	Ácido peracético - acuoso (6 %)	CH ₃ CO ₃ H	+	+	+	+			-			+	+
Petroleum - rein	Petroleum - pure	Petróleo - puro		+	-	+	+	+	+	+		o	+	+
Petroleumbenzin, Petrolether	Petroleum benzine, petroleum ether	Gasolina de petróleo, éter de petróleo		+	-	+	+	+		+		-	+	+
Pflanzenschutzmittel (Karbolineum)	Pesticide (carbolineum)	Plaguicida (carbolíneo)		o	o	+	+			o			+	+
Phenol - wässrig	Phenol - aqueous	Fenol - acuoso	C ₆ H ₅ OH	o	o	+	+	o	-	o	-	+	+	+
Phosgen (flüssig) - rein	Phosgene (liquid) - pure	Fosgeno (líquido) - puro	COCl ₂	o	-	+	+						+	+
Phosgen (gasförmig) - rein	Phosgene (gaseous) - pure	Fosgeno (gaseoso) - puro	COCl ₂	+	-	+	+					-	+	+
Phosphorchloride - rein	Phosphorous chloride - pure	Cloruro de fósforo - puro		o	-	+	+	+	-	-		-	o	o
Phosphorsäure - wässrig	Phosphoric acid - aqueous	Ácido fosfórico - acuoso	H ₃ PO ₄	+	o	+	+	+	-	o	+	+	+	-
Pikrinsäure (Trinitrophenol) - rein	Picric acid (trinitrophenol) - pure	Ácido pírico (trinitrofenol) - puro	C ₆ H ₂ (OH)(NO ₂) ₃	o	-	+	+	+		o	-	o	+	+
Pinen (Terpentinöl) - rein	Pinene (terpentine oil) - pure	Pineno (esencia de trementina) - puro		o	-	+	+	+	+	o		-	+	+
Pottasche (Kaliumcarbonat) - wässrig	Potash (potassium carbonate) - aqueous	Patasa (carbonato de potasio) - acuoso	K ₂ CO ₃	+	+	+	+	+	+	+	o	+	+	+
Propan (flüssig und gasförmig) - rein	Propane (liquid and gaseous) - pure	Propano (líquido y gaseoso) - puro	C ₃ H ₈	+	-	+	+	+	+	+	+	-	+	+
Propanol (Isopropanol) - rein	Propyl alcohol (isopropyl alcohol) - pure	Propanol (isopropanol) - puro	CH ₃ CH(OH)CH ₃	+	+	+	+	+	+	-	o	+	+	+
Propylenglykol - rein	Propylene glycol - pure	Propilenglicol - puro	HOCH ₂ CH ₂ CH ₂ OH	+	+	+	+	+	+	+	+	+	+	+
Pydraul-A 150	Pydraul-A 150	Pydraul-A 150		+	o	+				-			+	
Pydraul-A 200	Pydraul-A 200	Pydraul-A 200		+	o	+				-			+	
Pydraul-AG	Pydraul-AG	Pydraul-AG		+	+	+				-			+	
Pydraul-F-9	Pydraul-F-9	Pydraul-F-9		+	+	+				-			+	
Pyridin - rein	Pyridine - pure	Piridina - pura	C ₅ H ₅ N	-	-	+	+	+	+	-	-	o	+	o
Quecksilber	Mercury	Mercurio	Hg	+	+	+	+	+	+	+	+	+	o	+
Quecksilberchlorid - wässrig	Mercurous chloride - aqueous	Cloruro de mercurio - acuosas	HgCl ₂	+	+	+	+	+	o	+	+	+	o	o
Quecksilbersalze - wässrig	Mercury salts - aqueous	Salos de mercurio - acuosas		+	+	+	+	+		+	+		+	+
Rapsöl	Rapeseed oil	Aceite de colza		o	-	+	+	+		o			+	+
Rizinusöl	Castor oil	Aceite de ricino		o	-	+	+	+		o		+	+	+
Saccharin (Süßstoff)	Saccharin (sweetener)	Sacarina (edulcorante)		+	+	+				+			+	+
Salmiakgeist (Ammoniak - Wasser)	Ammonia solution (liquid ammonia)	Solución acuosa de amoníaco (amoníaco-agua)	NH ₄ OH	-	+	+	+	+	+	-	-	+	+	+
Salpetersäure - wässrig (40 %)	Nitric acid - aqueous (40 %)	Ácido nítrico - acuoso (40 %)	HNO ₃	3+	-	+	+	o	-	-	-	-	+	-
Salzsäure - wässrig (36 %)	Hydrochloric acid - aqueous (36 %)	Ácido nítrico - acuoso (36 %)	HCl	3+	o	+	+	o	-	-	+	+	+	o
Sauerstoff	Oxygen	Oxígeno	O ₂	5+	o	+	+	+	+	o		o	+	+
Schmieröle (vorwiegend Mineralöle)	Lubricating oils (mainly mineral oils)	Aceites lubricantes (principalmente aceites minerales)		+	-	+	+	+	+	+		-	+	+
Schwefelchlorid (-oydchlorid) - rein	Sulphur chloride (oxychloride) - pure	Cloruro de azufre (oxicloloro) - puro		+	-	+	+	+	-	-			+	-
Schwefeldioxid (flüssig) - rein	Sulphur dioxide (liquid) - pure	Dióxido de azufre (líquido) - puro	SO ₂	+	+	+	+	+	-	-	-	-	+	+
Schwefeldioxid (Gas, feucht)	Sulphur dioxide (gas, wet)	Dióxido de azufre (gas, húmedo)	SO ₂	+	+	+	+	+	-	-		-	+	o
Schwefeldioxid (Gas, trocken) - rein	Sulphur dioxide (gas, dry) - pure	Dióxido de azufre (gas, seco) - puro	SO ₂	+	+	+	+	+	-	-		-	+	o
Schwefelhexafluorid - rein	Sulphur hexafluoride - pure	Hexafluoruro de azufre - puro	SF ₆	o	+	+	o	+		+			+	+
Schwefelige Säure - wässrig	Sulphurous acid - aqueous	Ácido sulfuroso - acuoso	H ₂ SO ₃	+	+	+	+	+	-	-	o	+	+	-
Schwefelkohlenstoff - rein	Carbon bisulphide - pure	Sulfuro de carbono - puro	CS ₂	+	-	+	+		+	-	+	-	+	o
Schwefelsäure - konzentriert (96 %)	Sulphuric acid - concentrated (96 %)	Ácido sulfúrico - concentrado (96 %)	H ₂ SO ₄	o	-	+	+	-	-	-	-	-	-	-
Schwefelsäure - wässrig (30 %)	Sulphuric acid - aqueous (30%)	Ácido sulfúrico - acuoso (30%)	H ₂ SO ₄	+	+	+	+	o	-	o	o	+	-	-
Schwefelwasserstoff - wässrig	Hydrogen sulphide - aqueous	Ácido sulfhídrico - acuoso	H ₂ S	-	+	+	-	+	+	o		+	+	+
Seifenlösung - wässrig	Soap solution - aqueous	Solución jabonosa - acuosa		o	o	+	+		+	o			+	+
Silbernitrat - wässrig	Silver nitrate - aqueous	Nitrato de plata - acuoso	AgNO ₃	+	+	+	+	+	+	o			+	+
Silikonöl	Silicone oil	Aceite de silicona		+	+	+	+	+	+	+	+	+	+	+
Skydral 500	Skydral 500	Skydral 500		o	+	+	+	+		-			+	+
Skydral 7000	Skydral 7000	Skydral 7000		-	+	+	+			-			+	+
Soda (Natriumcarbonat)	Soda (sodium carbonate)	Soda (carbonato de sodio)		+	+	+	+	+	+	+		+	+	+
Sojaöl	Soybean oil	Aceite de soja		o	-	+	+	+	+	o			+	+
Sole (Kühlsolen)	Brine (cooling brine)	Salmueras (salmueras frigoríficas)		+	+	+	+	+		+			o	o
Speiseöl	Edible oil	Aceite comestible		o	-	+	+	+	+	o		+	+	+
Spindelöl (Mineralöle)	Spindle oil (mineral oil)	Aceite para ejes (aceites minerales)		+	-	+	+	+		+			+	+
Spirituosen - (abhängig von Inhalts- und Aromastoffen)	Spirits - (depends on ingredients and flavours)	Bebidas alcohólicas - (según ingredientes y aromas)		o	o	+		+	+	o		+	+	+
Stärkelösung - wässrig	Starch solution - aqueous	Solución de almidón - acuosa		+	+	+	+	+	+	+	+	+	+	+
Stearinsäure	Stearic acid	Ácido estearico	C ₁₈ H ₃₇ COOH	+	+	+	+		+	+	+	o	+	+
Stickoxide (Nitrose Gase)	Nitrogen oxide (nitrous fumes)	Óxidos de nitrógeno (gases nitrosos)		-	-	+	o	+	-	-			o	-
Stickoxydul (Distickstoffmonoyd)	Nitrous oxide (dinitrogen oxide)	Óxido nítrico (monóxido de dinitrógeno)	N ₂ O	+	+	+	+	+		+	+		+	+
Stickstoff	Nitrogen	Nitrógeno	N ₂	+	+	+	+	+	+	+	+		+	+

Chemikalien- beständigkeit	Resistance to chemicals	Resistencia a sustancias químicas		FKM	EPDM	PTFE	FFKM	PEEK	POM	NBR	PU	LD-PE	1.4401/1.4571	1.4305/1.4104
Styrol - rein	Styrene - pure	Estireno - puro	C ₆ H ₅ CHCH ₂	o	-	+	+	+	+	-	o	-	+	+
Sumpfgas (Methan)	Marsh gas (methane)	Gas de los pantanos (metano)	CH ₄	+	-	+	+	+	+	+	o	-	+	+
Tallöl	Tall oil	Talol		o	o	+				o			+	o
Tannin (Gerbsäure)	Tannin (tannic acid)	Tanino (ácido tánico)		+	+	+	+	+	-	+	o	+	+	+
Teeröl (Karbolineum)	Creosote (carbolineum)	Creosota (carbolineo)		o	o	+	+			o		+	+	+
Terpentin (Terpentinöl) - rein	Terpentine (terpentine oil) - pure	Trementina (esencia de trementina) - puro		o	-	+	+	+	+	o		-	+	+
Terpentinersatz (Testbenzin)	Terpentine substitute (solvent naphtha)	Espíritu de petróleo (gasolina de comprobación)		o	-	+	+	+	+	o		o	+	+
Testbenzin - rein (Shellsol D)	Solvent naphtha - pure (Shellsol D)	Gasolina de comprobación - pura (Shellsol D)		o	-	+	+	+		o		o	+	+
Tetrachlorethylen (Perchloroethylen)	Tetrachloroethylene (perchloroethylene)	Tetracloroetileno (percloroetileno)	Cl ₂ CCCl ₂	o	-	+	o	+	+	-	-	-	+	+
Tetrachlorkohlenstoff - rein	Carbon tetrachloride - pure	Tetracloruro de carbono - puro	CCl ₄	+	-	+	+	+	+	-		-	+	+
Tetraethylblei (Bleitetraethyl)	Tetraethyl lead (lead tetraethyl)	Tetraetilo de plomo (plomo tetraetilo)	Pb (CH ₂ CH ₃) ₄	+	o	+	+	+		o		+	+	+
Tetrahydrofuran - rein	Tetrahydrofurane - pure	Tetrahidrofurano - puro	C ₄ H ₈ O	-	-	+	+	+	+	+		-	+	+
Tetrahydronaphthalin (Tetralin) - rein	Tetrahydronaphthalene (Tetralin) - pure	Tetrahidronaftalina (tetralina) - pura	C ₁₀ H ₁₂	+	-	+	+		+	-		-	+	+
Thiophen - rein	Thiophene - pure	Tiofeno - puro	C ₄ H ₄ S	-	-	+	+			-		-	+	+
Toluol - rein	Toluol - pure	Tolueno - puro	C ₆ H ₅ CH ₃	o	-	+	+	+	+	-	-	-	+	+
Traubenzucker (Glukose) - wässrig	Dextrose (glucose) - aqueous	Azúcar de uvas (glucosa) - acuosa	C ₆ H ₁₂ O ₆	+	+	+	+	+	+	+	+	+	+	+
Tributylphosphat - rein	Tributylphosphate - pure	Fosfato de tributilo - puro	PO(OC ₄ H ₉) ₃	-	-	+	o			-	-	+	+	+
Trichloressigsäure - wässrig	Trichloroacetic acid - aqueous	Ácido tricloroacético - acuoso	(Cl) ₃ CCOOH	-	o	+	+		-	o		-	-	-
Trichlorethylen - rein	Trichloroethylene - pure	Tricloroetileno - puro	Cl ₂ CCCl	o	-	+	+	+	-	-	-	-	+	+
Trichlormethan (Chloroform)	Trichloromethane (chloroform)	Triclorometano (cloroformo)	CHCl ₃	+	-	+	+	+	-	-	-	-	+	+
Triethanolamin - rein	Triethanolamine - pure	Trietanolamina - pura	N(CH ₂ CH ₂ OH) ₃	-	-	+	+	+	+	-	o	+	+	+
Triresylphosphat - rein	Triorthocresylphosphate - pure	Fosfato de tricresilo - puro		-	-	+	+			+			+	+
Uranhexafluorid - rein	Uranium hexafluoride - pure	Hexafluoruro de uranio - puro	UF ₆	+	+	+	o			+			+	o
UV-Lack	UV varnish	Pintura UV		-	+	+				-				
Vaselinöl (Mineralöle)	Vaseline oil (mineral oil)	Aceite de vaselina (aceites minerales)		+	-	+	+	+	+	+		-	+	+
Vinylacetat - rein	Vinyl acetate - pure	Acetato de vinilo - puro	CH ₂ CHOOCH ₂ CH ₃	+	+	+	+			+		+	+	+
Vinylchlorid - rein	Vinyl chloride - pure	Cloruro de vinilo - puro	CH ₂ CHCl	+	o	+	+			-	-	o	o	o
Waschmittel (synth. Haushaltswaschmittel)	Detergent (synth. household detergent)	Detergentes (detergentes domésticos sintéticos)		o	+	+	+			o		+	+	+
Wasser - destilliert	Water - distilled	Agua - destilada	H ₂ O	+	+	+	+	+	+	+	+	+	+	o
Wasser - Meerwasser	Water - seawater	Agua - agua de mar	H ₂ O	+	+	+	+	+	+	+	+	+	o	o
Wasserdampf - (Elastomerdichtungen bis +130 °C)	Steam - (elastomer seals up to +130 °C)	Vapor de agua - (juntas elastoméricas hasta +130 °C)	H ₂ O	3+	+	+	+	+		o	-		+	+
Wasserglas (Natriumsilikate)	Soluble glass (sodium silicate)	Vidrio soluble (silicato de sodio)		+	+	+	+	+		+		+	+	+
Wasserstoff - rein	Hydrogen - pure	Hidrógeno - puro	H ₂	+	+	+	+	+		+	+	+	+	+
Wasserstoffperoxyd 0.5 %	Hydrogen peroxide 0.5 %	Peróxido de hidrógeno 0,5 %	H ₂ O ₂	+	+	+	+	+	-	o	+	+	+	o
Wasserstoffperoxyd 30 %	Hydrogen peroxide 30 %	Peróxido de hidrógeno 30 %	H ₂ O ₂	3+	o	+	+	+	-	-	+	+	o	-
Weine	Wines	Vinos		+	+	+		+		+		+	+	+
Weinessig (Essigsäure)	Wine vinegar (acetic acid)	Vinagre de vino (ácido acético)		-	o	+	o	+		-		o	o	o
Weinsäure - wässrig	Tartaric acid - aqueous	Ácido tartárico - acuoso		+	+	+	+	+		+	+	+	+	+
Xenon	Xenon	Xenón	Xe	+	+	+	+	+	+	+	+	+	+	+
Xylol - rein	Xylene - pure	Xileno - puro	C ₆ H ₄ (CH ₃) ₂	+	-	+	+	+	+	-	-	-	+	+
Zinkchlorid - wässrig	Zinc chloride - aqueous	Cloruro de cinc - acuoso	ZnCl ₂	+	+	+	+	+	+	+	+	+	+	o
Zinksulfat - wässrig	Zinc sulphate (white vitriol) - aqueous	Sulfato de cinc - acuoso	ZnSO ₄	+	+	+	+	+	+	+	+	+	+	-
Zinnchloride - wässrig	Tin chloride - aqueous	Cloruros de estaño - acuosos		+	+	+	+	+		+	+	+	+	o
Zitronensaft	Lemon juice	Zumo de limón		+	+	+		+	+	o		+	+	o
Zitronensäure - wässrig	Citric acid - aqueous	Ácido cítrico - acuoso		+	+	+	+	+	+	+	+	+	+	o
Zuckerlösungen	Sugar solutions	Soluciones azucaradas		+	+	+		+		+		+	+	+

1) bei Messing mit bis zu 58 % Cu	1) for brass with up to 58 % Cu	1) Para latón con hasta 58 % Cu												
2) diffundiert durch EPDM-Membranen; greift Epoxidharz an	2) diffuses through EPDM membrane; attacks epoxy resin	2) Difunde a través de membranas EPDM; ataca resinas de epoxi												
3) FKM in säurebeständiger Ausführung mit Bleiglätte	3) FKM in acid-resistant version with litharge	3) FKM en versión resistente a los ácidos con litargirio												
4) Ozon schädigt die meisten polymeren Werkstoffe. Die Beständigkeiten sind daher zu relativieren	4) ozone damages most polymeric materials. Resistance should therefore be relativised.	4) El ozono daña la mayoría de polímeros, de forma que las resistencias son relativas.												
5) unter Druck zugelassen (getestet durch die BAM)	5) approved under pressure (tested by BAM)	5) Uso autorizado en condiciones de presión (testado dal BAM)												
6) Wasserstoff kann zur Versprödung von Metallen führen	6) hydrogen can cause metals to become brittle	6) El hidrógeno puede provocar que los metales se vuelvan frágiles												

Allgemeine Verkaufs- und Lieferbedingungen

1. Allgemeines und Geltungsbereich

Die Allgemeinen Geschäftsbedingungen gelten für alle SERTO Group Gesellschaften (SERTO AG, SERTO GmbH, SERTO S.A.R.L., EXMAR GmbH, SERTO Italiana S.r.l. und SERTO CZ s.r.o.) im folgenden "Lieferant" genannt. Die Angebote, Auftragsbestätigungen, Lieferungen und Leistungen erfolgen ausschließlich aufgrund dieser Geschäftsbedingungen. Änderungen, Ergänzungen oder entgegenstehende Bedingungen des Auftraggebers/Käufers/Bestellers gelten nur dann, wenn sie von uns im Einzelfall ausdrücklich schriftlich bestätigt werden. Mit der Auftragserteilung, spätestens jedoch mit dem Empfang der Ware, gelten unsere Allgemeinen Verkaufs- und Lieferbedingungen vom Käufer als angenommen.

2. Angebot und Vertragsabschluss

Unsere Angebote sind freibleibend. Schriftlich, mündlich oder fermündlich erteilte Aufträge werden erst durch unsere schriftliche Auftragsbestätigung für uns verbindlich. Bei Fertigung nach Kundenmuster/-zeichnung behalten wir uns eine Mehr- bzw. Minderlieferung bis zu 10 % (bei Auftragsmenge kleiner als 10 Stück behalten wir uns eine Mehr- bzw. Minderlieferung von 1 Stück) vor. Bei Bestellung auf der Grundlage der jeweils neuesten Ausgabe unserer Unterlagen, wie Kataloge, Preislisten oder Prospekte, ist zu berücksichtigen, dass unsere Angaben (insbesondere die technischen) insoweit unverbindlich sind, soweit nicht anderes ausdrücklich vereinbart ist oder sich aus einer entsprechenden Bezeichnung in den Unterlagen ergibt. Im Übrigen verstehen sich unsere Angaben in Unterlagen, wie Katalogen oder Prospekten, als Aufforderung zur Abgabe eines Angebotes. Eine vertragliche Bindung unsererseits bedarf einer schriftlichen Auftragsbestätigung, welche zugleich den Umfang der vertraglichen Verpflichtung festlegt. Weichen in der Auftragsbestätigung Angaben vom Angebot des Auftraggebers/Käufers/Bestellers ab, hat dieser unverzüglich zu widersprechen, wenn der Vertrag nicht zu diesen geänderten Bedingungen zustande kommen soll. Nachträgliche Ergänzungen, Änderungen oder Nebenabreden bedürfen der Schriftform. Wenn sich die Zahlungsfähigkeit oder die Vermögensverhältnisse des Auftraggebers/Käufers/Bestellers nach Vertragsabschluss so wesentlich verändert haben, dass unser Anspruch auf die Gegenleistung gefährdet wird, sind wir berechtigt, die Erfüllung des Vertrages zu verweigern, bis der Auftraggeber/Käufer/Besteller die Gegenleistung bewirkt oder Sicherheit für sie geleistet hat. Ist der Auftraggeber/Käufer/Besteller nicht in der Lage, innerhalb angemessener Frist die geforderte Sicherheit zu leisten, so sind wir zum Rücktritt berechtigt.

3. Preise / Lieferung

Preise des Lieferanten sind freibleibend und werden von der SERTO GmbH, SERTO S.A.R.L., SERTO Italiana S.r.l. und EXMAR GmbH in Euro und von der SERTO AG in Schweizer Franken (CHF) angegeben und gelten ab Werk (INCOTERMS 2020), jedoch ausschließlich Verpackung, Transportkosten, Zuschläge für Mindestauftragswert (Mindermengenzuschläge), Versicherung und der jeweils gültigen gesetzlichen Mehrwertsteuer. Die Umsatzsteuer wird gesondert ausgewiesen zu dem am Tage der Rechnungsstellung gültigen Steuersatz. Lieferungen erfolgen immer ab Werk.

4. Lieferungen, Liefer- und Leistungszeit

Die Vereinbarung von Terminen und Fristen bei Vertragsabschluss bedarf der Schriftform. Dasselbe gilt für deren nachträgliche Vereinbarung oder Änderung. Die Einhaltung einer Lieferfrist setzt den rechtzeitigen

General terms of sale and delivery

1. General and Scope of Validity

The General Terms and Conditions shall apply to all companies within the SERTO Group (SERTO AG, SERTO GmbH, SERTO S.A.R.L., EXMAR GmbH, SERTO Italiana S.r.l. and SERTO CZ s.r.o.), hereinafter referred to as the "Supplier". These General Terms and Conditions shall be exclusively valid for offers, order confirmations, deliveries and services. Modifications, supplements or conflicting conditions of the customer/purchaser/orderer shall only be applicable when expressly confirmed in writing in each individual case. By placing the order, or at the latest upon receipt of the goods, the purchaser acknowledges our General Terms and Conditions of Sale and Delivery.

2. Offers and Contracts

Our offers are subject to change. Orders placed in writing, verbally or by telephone shall only become binding for us with our written order confirmation. For manufactures according to customer samples/drawings, we reserve the right to an excess or short delivery of up to 10 % (for order quantities under 10 pieces, we reserve the right to an excess or short delivery of 1 piece). With respect to orders based on the most recent version of our documentation, such as catalogues, price lists or brochures, it shall be borne in mind that our information (in particular technical data) is non-binding in so far as no other agreements are specifically made or corresponding designation is contained in the documentation. In addition, our information in documentation, such as catalogues or brochures, shall be understood as an invitation to submit a quotation. A binding contract for our part requires a written order confirmation which establishes the extent of the contractual obligation. Should the order confirmation show information which deviates from that in the offer of the customer/purchaser/orderer, he must notify us immediately if the contract is not to be pursued under these altered conditions. Subsequent additions, modifications or other agreements must be made in writing. If, after conclusion of the contract, the ability to pay or the financial circumstances of the customer/purchaser/orderer have deteriorated to the extent that our right to compensation is jeopardised, we shall be entitled to refuse fulfilment of the contract until which time the customer/purchaser/orderer shall effect such consideration or provide a security for it. Should the customer/purchaser/orderer not be able to provide the required security within an appropriate time, we shall be entitled to withdraw from the contract.

3. Prices/Delivery

The Supplier's prices shall be subject to change and are given by SERTO GmbH, SERTO S.A.R.L., SERTO Italiana S.r.l. and EXMAR GmbH in Euro, by SERTO AG in Swiss francs (CHF), ex works (INCOTERMS 2020), but excluding packaging, transport costs, minimum order charge, insurance and the applicable statutory value-added tax. The sales tax shall be shown separately at the rate applicable on the day of invoicing. Deliveries shall always be made ex works.

4. Deliveries, Time of Delivery and Performance

The dates and deadlines must be agreed in writing upon conclusion of the contract. The same holds true for subsequent agreements or amendments. Adherence to a delivery time shall be subject to the timely receipt of all documents, parts and information to be supplied by the customer/purchaser/orderer as well as any advance payments contractually or legally owed by the customer/purchaser/orderer. If these requirements are not met, the delivery time shall be extended accordingly. The day of delivery shall be considered the

Condiciones generales de venta y entrega

1. Generalidades y ámbito de aplicación

Las condiciones generales de venta serán aplicables a todas las sociedades de SERTO Group (SERTO AG, SERTO GmbH, SERTO S.A.R.L., EXMAR GmbH, SERTO Italiana S.r.l. y SERTO CZ s.r.o.), en lo sucesivo denominadas el "Proveedor". Las ofertas, confirmaciones de pedido, entregas y prestaciones se realizarán únicamente en base a las presentes condiciones generales de venta. Las modificaciones, añadiduras o condiciones opuestas del contratante/comprador/cliente solo serán aplicables cuando en cada caso particular nosotros lo hayamos confirmado expresamente por escrito. Nuestras condiciones generales de venta y entrega se considerarán aceptadas por el comprador en el momento de la adjudicación del pedido, a más tardar no obstante en el momento de la recepción de los productos.

2. Oferta y conclusión del contrato

Nuestras ofertas no son vinculantes. Los pedidos adjudicados de forma escrita, oral o telefónica serán vinculantes para nosotros una vez los hayamos confirmado por escrito. En caso de fabricación según el diseño/dibujo del cliente, nos reservamos el derecho a entrega por encima o por debajo del pedido de hasta el 10% (en caso de una cantidad de pedido inferior a las 10 unidades, nos reservamos el derecho a entrega por encima o por debajo del pedido de 1 unidad). En caso de realización del pedido sobre la base de la edición más actualizada en cada momento de nuestra documentación, como catálogos, listas de precios o prospectos, deberá tenerse en cuenta que nuestros datos (sobre todo los datos técnicos) no son vinculantes en la medida en que no se haya acordado expresamente algo distinto o que ello resulte de la mención correspondiente en la documentación. Por lo demás, los datos contenidos en nuestra documentación, como catálogos o prospectos, se entenderán como requerimiento para la presentación de una oferta. Para que exista compromiso contractual por nuestra parte, es necesaria la confirmación por escrito del pedido que, a su vez, determinará el alcance de la obligación contractual. En caso de discrepancia entre los datos de la confirmación del pedido y los datos de la oferta del contratante/comprador/cliente, éste deberá objetar de inmediato para que el contrato no se celebre de acuerdo con estas condiciones modificadas. Las añadiduras, modificaciones o cláusulas accesorias posteriores deberán realizarse por escrito. Cuando la solvencia o la posición económica del contratante/comprador/cliente haya cambiado tanto tras la formalización del contrato hasta el punto de que nuestro derecho a la contraprestación se viera comprometido, estamos facultados para negarnos a ejecutar el contrato hasta que el contratante/comprador/cliente haga efectiva la contraprestación o constituya una garantía para tal fin. En caso de que el contratante/comprador/cliente no sea capaz de constituir la garantía exigida dentro de un plazo razonable, estamos facultados a desistir del contrato.

3. Precios / entrega

Los precios del Proveedor no son vinculantes y se expresan en euros en el caso de SERTO GmbH, SERTO S.A.R.L., SERTO Italiana S.r.l. y EXMAR GmbH, y en francos suizos (CHF) en el caso de SERTO AG, y se consideran franco fábrica (INCOTERMS 2020), sin incluir el embalaje, los costes de transporte, suplementos por valor mínimo del contrato (suplementos por cantidades pequeñas), el seguro y el impuesto sobre el valor añadido legalmente vigente. El impuesto sobre el volumen de negocio se contemplará por separado en virtud del tipo impositivo vigente el día de la emisión de la factura. Las entregas se realizarán siempre franco fábrica.

4. Entregas, fecha de entrega y fecha de prestación

La estipulación de fechas y de plazos en el momento de formalización del contrato debe realizarse por escrito. Lo

AGB Fortsetzung

Terms and Conditions continuation

Condiciones generales continuación

Eingang sämtlicher vom Auftraggeber/Käufer/Besteller zu liefernden Unterlagen, Teile und Angaben sowie die Erbringung von vertraglich oder gesetzlich geschuldeten Vorleistungen des Auftraggeber/Käufer/Bestellers voraus. Werden diese Voraussetzungen nicht erfüllt, verlängert sich die Lieferfrist entsprechend. Als Tag der Lieferung gilt der Tag, an dem die Ware dem Auftraggeber/Käufer/Besteller abholbereit gemeldet wurde. Falls Versendung geschuldet ist, gilt als Tag der Lieferung der Tag, an dem die Ware an die Transportperson übergeben wird. Liefer- und Leistungsschwierigkeiten aufgrund von Ereignissen höherer Gewalt, die erst nach Abschluss des Vertrages eintreten und uns auch erst danach ohne Verschulden bekannt werden (wie z. B. unvorhersehbare Betriebsstörungen, Streiks, Aussperrungen, unvermeidbare Materialbeschaffungsschwierigkeiten und dergleichen), haben wir nicht zu vertreten. Ist das Leistungshindernis vorübergehender Art, so verlängert sich die Liefer- und Leistungszeit angemessen. Hat das Ereignis höherer Gewalt dauerndes Unvermögen zur Folge, so sind wir berechtigt, wegen des noch nicht erfüllten Teiles ganz oder teilweise von dem Vertrag zurückzutreten. Bei Abrufaufträgen, deren Erfüllung aus mehreren Teillieferungen besteht, können aus Lieferstörungen bei einer Teillieferung keine Rechte wegen anderer Teillieferungen dieses Auftrages geltend gemacht werden, es sei denn, der Auftraggeber/Käufer/Besteller weist nach, dass die teilweise Erfüllung des Vertrages für ihn kein Interesse hat. Dasselbe gilt, wenn die Teillieferung im Verhältnis zur Gesamtlieferung geringfügig ist. Bei Abrufaufträgen, deren Erfüllung aus mehreren Teillieferungen besteht, sind wir berechtigt, die gesamte Bestellmenge sofort herzustellen. Etwaige Änderungswünsche des Auftraggebers/Käufers/Bestellers können nach Erteilung unserer Auftragsbestätigung nicht mehr berücksichtigt werden. Zu Teillieferungen und Teilleistungen sind wir in zumutbarem Umfang berechtigt. Unvermeidbare Mengenabweichungen/Fertigungsergebnisse nach oben oder unten bis zu 10 % sind ohne entsprechende Anpassung des Kaufpreises anzuerkennen.

5. Gefahrübergang

Wir liefern auf Gefahr und Kosten des Auftraggebers/Käufers/Bestellers. Die Gefahr geht auf den Auftraggeber/Käufer/Besteller über, sobald die Ware zwecks Versendung unser Werk oder eines unserer Außenlager verlassen hat. Wird der Versand durch Umstände verzögert oder unmöglich, die der Auftraggeber/Käufer/Besteller zu vertreten hat, so geht die Gefahr am Tage der Meldung der Versandbereitschaft auf den Auftraggeber/Käufer/Besteller über. Angelieferte Gegenstände sind, auch wenn sie Mängel aufweisen, vom Auftraggeber/Käufer/Besteller unbeschadet der Rechte aus Abschnitt 6. entgegenzunehmen.

6. Gewährleistung

Geringfügige und/oder unerhebliche Abweichungen oder Änderungen gegenüber den Katalogen oder früher gelieferten Waren gelten nicht als Mangel. Unsere Angaben zum Liefer- und Leistungsgegenstand in unseren Katalogen, Prospekten und Preislisten stellen lediglich Beschreibungen, Kennzeichnungen und Richtwerte dar. Die Zusicherung von Eigenschaften und der Ausschluss branchenüblicher Abweichungen bedürfen in jedem Einzelfall der ausdrücklichen schriftlichen Vereinbarung. Für die von uns gelieferten Waren gelten die jeweils in den Ländern gültigen Untersuchungs- und Rügepflichten. Der Auftraggeber/Käufer/Besteller hat uns etwaige Mängel unverzüglich, erkennbare Mängel spätestens innerhalb 1 Woche nach Eingang der Ware, verdeckte Mängel spätestens innerhalb von 1 Woche nach Entdeckung unter eingehender Beschreibung schriftlich mitzuteilen. Die

day on which the goods are reported to the customer/purchaser/orderer as ready for pickup. If shipping is owed, the day of delivery shall be the day on which the goods are consigned to the forwarder. We shall not bear responsibility for delivery and performance difficulties due to force majeure events that take effect after conclusion of the contract and that are only known to us after the fact through no fault of our own (such as e.g. unforeseeable interruptions in operation, strikes, lockouts, unavoidable difficulties in material procurement and the like). If the obstacle to performance is of a temporary nature, the delivery and performance time shall be extended accordingly. If, however, the event of force majeure should result in a permanent inability to perform, we shall be entitled to withdraw as a whole or in part from the contract concerning the part not yet fulfilled. For call orders consisting of several partial shipments, no rights may be asserted for other partial shipments of this order on the basis of delivery problems for one partial shipment unless the customer/purchaser/orderer submits proof that partial fulfilment of the contract is of no interest to him. The same applies should the partial shipment be insignificant in comparison to the overall delivery. For call orders consisting of several partial shipments, we shall be entitled to manufacture the entire order amount immediately. Any change requests on the part of the customer/purchaser/orderer cannot be taken into account after our order confirmation has been issued. We are entitled to make partial deliveries and partial performance to a reasonable extent. Unavoidable upward or downward deviations in amounts / manufacturing results of up to 10% shall be allowed without any adjustments in the purchase price.

5. Passing of risk

We deliver at the risk and cost of the customer/purchaser/orderer. Risk passes to the customer/purchaser/orderer as soon as the goods leave our plant or one of our external storage areas for shipment. If shipment is delayed or not possible due to circumstances for which the customer/purchaser/orderer is responsible, the risk shall pass to the customer/purchaser/orderer on the day of notification of readiness to dispatch. The customer/purchaser/orderer shall accept delivered goods even if they exhibit defects irrespective of the rights stipulated in Paragraph 6.

6. Warranty

Minor and/or insignificant deviations or modifications compared to the catalogues or previously supplied goods shall not be considered a defect. The information regarding our goods and services provided in our catalogues, brochures and price lists merely constitutes descriptions, identifications and reference values. The assurance of characteristics and the exclusion of deviations customary in the trade shall be subject to explicit written agreement in each individual case. For goods supplied by us, the inspection duties and the complaint notification obligation valid in the respective countries shall apply. The customer/purchaser/orderer must report any defects immediately to us in writing and in full; visible defects are to be reported at the latest within one week of receipt of the goods, hidden defects at the latest within one week of detection. Warranty claims may not be put forward after the notification period has elapsed, as well as after 24 months of the passing of risk. For justified and accurately timed notifications of defect, our warranty obligation shall be limited, at our discretion, to reworking the goods or replacing them. Regardless of the fact whether we rework or supply new parts, only parts that exhibit a defect in the material or in our workmanship shall be replaced. Should subsequent deliveries or improvements fail, the customer/purchaser/orderer may only choose to demand a reduction in payment or termination of the contract. Claims for damages by the customer/

mismo será de aplicación para su estipulación posterior o modificación. El cumplimiento de una fecha de entrega establece como condición la entrada puntual de todos los documentos, piezas y datos que el contratante/comprador/cliente deba entregar, así como el pago de los anticipos adeudados contractual o legalmente por parte del contratante/comprador/cliente. Si no se cumplen estas condiciones, se prorrogará el plazo de entrega correspondientemente. El día de entrega será el día en que los productos del contratante/comprador/cliente se hayan declarado listos para ser recogidos. En caso de que se adeude la expedición, se considerará el día de entrega el día en que se haga entrega de los productos al transportista. No nos responsabilizamos de las dificultades de entrega y de prestación con motivo de acontecimientos de fuerza mayor que surjan tras la formalización del contrato y que se nos comuniquen también posteriormente sin mediar incumplimiento (por ejemplo, averías imprevisibles, huelgas, cierres patronales, dificultades en el aprovisionamiento de materiales y similares). Si la circunstancia imprevista es de tipo temporal, la fecha de entrega y de prestación se prorrogará de forma razonable. En caso de que el suceso de fuerza mayor provoque una imposibilidad duradera, estamos facultados a desistir del contrato total o parcialmente con motivo de la parte que todavía no se haya cumplido. Cuando un pedido sea abierto y su cumplimiento consista en varias entregas parciales, en caso de dificultades en una entrega parcial, no podrá ejercitarse ningún derecho sobre otras entregas parciales de este pedido, salvo que el contratante/comprador/cliente demuestre que el cumplimiento parcial del contrato no reviste para él interés alguno. Lo mismo será válido cuando la entrega parcial sea insignificante en relación con la entrega íntegra. Cuando un pedido sea abierto y su cumplimiento consista en varias entregas parciales, estamos facultados a fabricar de inmediato la cantidad de pedido total. Una vez hayamos confirmado el pedido, ya no podrán tenerse en cuenta las eventuales peticiones de cambio del contratante/comprador/cliente. Estamos facultados a realizar entregas parciales y prestaciones parciales dentro de un marco razonable. Los ajustes en las cantidades/resultados de producción inevitables que oscilen hasta en un 10% tanto hacia arriba como hacia abajo se reconocerán sin necesidad de adaptar de forma correspondiente el precio de compra.

5. Transferencia de riesgos

Realizamos la entrega por cuenta y riesgo del contratante/comprador/cliente. El riesgo se transferirá al contratante/comprador/cliente tan pronto como los productos hayan salido de nuestra fábrica o de uno de nuestros almacenes externos para la expedición. En caso de que el envío se retrasara o resultara imposible por circunstancias atribuibles al contratante/comprador/cliente, el riesgo se transferirá al contratante/comprador/cliente el día de la comunicación de la disponibilidad del envío. El contratante/comprador/cliente aceptará los productos entregados, incluso en el caso de que presenten deficiencias, sin perjuicio de los derechos del apartado 6.

6. Garantía

Las desviaciones o modificaciones insignificantes en relación con los catálogos o los productos entregados anteriormente no se considerarán deficiencias. Nuestros datos sobre el objeto de la entrega y de la prestación contenidos en nuestros catálogos, prospectos y listas de precios representan únicamente descripciones, identificaciones y valores de referencia. La promesa de características y la exclusión de las desviaciones habituales en el sector precisarán en cada caso particular del acuerdo expreso por escrito. Para los productos que entregamos serán de aplicación las obligaciones de examen y denuncia vigentes en cada país. El contratante/comprador/cliente deberá comunicarnos con una descripción detallada por escrito las posibles deficiencias de inmediato, las deficiencias reconocibles en el plazo a más tardar de 1 semana tras la entrada de los productos, las deficiencias ocultas en el

AGB Fortsetzung

Terms and Conditions continuation

Condiciones generales continuación

Geltendmachung von Gewährleistungsansprüchen ist ausgeschlossen, falls Mängelrügefristen versäumt werden, ferner falls seit Gefahrübergang 24 Monate verstrichen sind. Im Falle rechtzeitiger und berechtigter Mängelrügen ist unsere Gewährleistungspflicht nach unserer Wahl auf Nachbesserung oder Ersatzlieferung beschränkt. Bessern wir nach oder liefern wir neu, werden nur Teile ersetzt, die einen Fehler in Werkstoff oder in der von uns geleisteten Werkarbeit aufweisen. Schlagen Nachlieferungen oder -besserungen fehl, so kann der Auftraggeber/Käufer/Besteller nur Herabsetzung der Vergütung oder nach seiner Wahl Rückgängigmachung des Vertrages verlangen. Für Schadensersatzansprüche des Auftraggebers/Käufers/Bestellers gilt Abschnitt 7. Schadensersatz wegen eines etwaigen Mängelfolgeschadens steht dem Auftraggeber/Käufer/Besteller nur für den Fall zu, dass bei Nichtvorliegen von uns ausdrücklich zugesicherter Eigenschaften das Risiko eines Mängelfolgeschadens durch die zugesicherte Eigenschaft ausgeschlossen werden sollte. Jegliche Gewährleistung ist ausgeschlossen für Mängel, die auf Nichtbefolgen oder Nichteinhalten der Montageanweisung und Einbauempfehlungen, auf fahrlässiger oder unsachgemäßer Behandlung, auf anderen Einsätzen oder anderer Verwendung unserer Waren oder unserer Leistungen als vertraglich vorgesehen, auf angegebenen Fremdmitteln oder auf Änderungen oder Instandsetzungsarbeiten beruhen, die seitens des Auftraggebers/Käufers/Bestellers oder Dritter unsachgemäß ohne unsere vorherige Genehmigung vorgenommen worden sind. Liegt ein Ausschlussstatbestand vor, trägt der Auftraggeber/Käufer/Besteller die Beweislast dafür, dass der von ihm geltend gemachte Mangel nicht durch ein zum Ausschluss führendes Verhalten verursacht wurde.

7. Schadensersatzansprüche

Wir haften nicht für bei Vertragsabschluss nicht vorhersehbare Schäden aller Art infolge Nichtlieferung oder verspäteter Lieferung, infolge einer Verletzung sonstiger vertraglicher Pflichten, für die Verletzung von Pflichten bei Vertragsabschluss sowie für Schäden aus unerlaubter Handlung. Das gilt nicht, wenn uns Vorsatz oder grobe Fahrlässigkeit zur Last fällt, wenn es sich um Fälle anfänglichen Unvermögens oder um die Verletzung einer für die Erreichung des Vertragszwecks wesentlichen Verpflichtung oder um die Verletzung einer betrieblichen Organisationspflicht zur Vermeidung von Konstruktions-, Fabrikations- und Gebrauchsmängeln handelt.

8. Eigentumsvorbehalt

Bis zur Erfüllung - bei Zahlung durch Wechsel oder Scheck bis zur erfolgten Einlösung - aller Saldo-Forderungen, die uns, aus welchem Rechtsgrund auch immer, gegen den Auftraggeber/Käufer/Besteller zustehen, bleibt die Ware unser Eigentum. Daneben werden uns die folgenden Sicherheiten gewährt, die wir auf Verlangen nach Wahl des Käufers/Bestellers freigeben, soweit ihr Wert die Forderungen um mehr als 15 % übersteigt. Eine Be- und Verarbeitung erfolgt stets unentgeltlich für uns als Hersteller, jedoch ohne Verpflichtung für uns, so dass wir in jedem Zeitpunkt und Grad der Verarbeitung an den Erzeugnissen Eigentum behalten. Der Auftraggeber/Käufer/Besteller verwahrt unser Eigentum unentgeltlich. Bei Verbindung/Vermischung mit uns nicht gehörenden Waren durch den Verkäufer/Käufer/Besteller und einem dadurch bedingten Eigentumsverlust wird bereits jetzt vereinbart, dass das entstehende Miteigentum des Auftraggebers/Käufers/Bestellers an der neuen Sache in Höhe des Rechnungsbetrages im Verhältnis zum Wert der neuen Ware nach Verarbeitung anteilmäßig zum Zeitpunkt der Verbindung/Vermischung auf uns übergeht und diese unentgeltlich durch den Auftraggeber/Käufer/Besteller verwahrt wird. Der

purchaser/orderer are governed under Paragraph 7. The customer/purchaser/orderer shall be entitled to compensation for any consequential damages caused by a defect only in the event that the risk of consequential damages due to the guaranteed characteristic should be excluded when an expressly guaranteed characteristic is not present. Any warranty is excluded for defects based on non-compliance or non-adherence to the assembly instructions and installation recommendations, on negligent or improper handling, on other applications or other uses of our goods or services than foreseen in the contract, on given outside resources or on modifications or repair work undertaken improperly by the customer/purchaser/orderer or third parties without our prior approval. If there is a state of exclusion, the customer/purchaser/orderer shall bear the burden of proving that the defect asserted by him was not caused by behaviour leading to exclusion.

7. Claims for damages

We shall not be held liable for all types of damages unforeseeable at the time of concluding the contract due to non-delivery or delayed delivery, due to violation of other contractual obligations, for violations of obligations upon conclusion of the contract as well as for damages due to unlawful acts. This does not apply unless it can be shown that we have acted wilfully or with gross negligence, unless it is a case of initial inability or the violation of an obligation essential to meeting contractual ends or the violation of the organisational duty of the company to prevent defects arising from design, production and use.

8. Retention of title

Until the customer/purchaser/orderer has settled all outstanding claims - in case of payment by draft or cheque until redemption of such - to which we are entitled for any legal reason, the goods shall remain our property. In addition, the following securities shall be granted us, which we may release on request at the discretion of the purchaser/orderer, provided their value exceeds the claims by more than 15%. Processing or working the goods is always free for us as the manufacturer, but without any obligation on our part, so that we retain title to the goods at all times and every degree of the processing. The customer/purchaser/order shall keep custody of our property free of charge. Should the customer/purchaser/orderer merge or combine our goods with other goods not belonging to us, thus causing a loss of ownership, it is hereby agreed that we shall acquire a share in the joint ownership of the customer/purchaser/orderer in the new item in the total amount of the invoice proportional to the value of the new goods after processing at the time of combining/merging and that the customer/purchaser/orderer shall keep custody of them gratuitously. The customer/purchaser/orderer shall be obligated to protect our property/joint property from deterioration, spoilage or loss with the proper care and diligence, also against his customers/purchasers/orderers. The customer/purchaser/orderer shall be entitled to process and to sell the reserved-title goods in the normal course of business, provided that he is not in arrears. Claims deriving from the resale of the reserved-title goods or other legal reasons pertaining to these goods, including all types of balance claims, are hereby assigned to us by way of security in full together with all ancillary rights. We provisionally authorise him to collect in his own name and for his own account all claims ceded to us and to forward the proceeds to us when payment is due. Has the authorisation to collect been revoked, the customer/purchaser/orderer shall be required at our request to disclose the assignments and to make available to us the necessary information and documents. It is not permitted to pledge or assign the reserved-title goods as a security. If a third party attempts to secure the reserved-title goods, the customer/

plazo a más tardar de 1 semana tras su descubrimiento. La aplicación de derechos de garantía quedará excluida en caso de que se descuiden los plazos de notificación de deficiencias, y además si hubieran transcurrido 24 meses desde la transmisión del riesgo. En caso de notificación de deficiencias puntual y procedente, nuestra obligación de garantía se limitará a elección nuestra a la reparación o al reemplazo. Tanto si optamos por la reparación como por el reemplazo, solo se sustituirán las piezas que presenten un defecto en los materiales o en el trabajo realizado por nosotros. En caso de que el reemplazo o la reparación fracasaran, el contratante/comprador/cliente podrá únicamente exigir la reducción de la remuneración o, a su elección, la cancelación del contrato. Para los derechos de indemnización por daños y perjuicios del contratante/comprador/cliente, será de aplicación el apartado 7. La indemnización por daños y perjuicios con motivo de posibles daños derivados de deficiencias solo le corresponderá al contratante/comprador/cliente cuando, en caso de ausencia de características aseguradas expresamente por nosotros, el riesgo de un daño derivado de deficiencias debería haberse excluido a través de la característica asegurada. Se excluye toda garantía para deficiencias que consistan en la inobservancia o el incumplimiento de las instrucciones de montaje y las recomendaciones de instalación, en la manipulación negligente o inadecuada, en aplicaciones o usos de nuestros productos o servicios distintos a los estipulados contractualmente, en medios ajenos especificados o en modificaciones o trabajos de conservación que el contratante/comprador/cliente o terceros hayan realizado de forma inadecuada o sin nuestro consentimiento previo. En caso de que exista un motivo de exclusión, recaerá sobre el contratante/comprador/cliente la carga de que la deficiencia reclamada no es resultado de un comportamiento que ha dado lugar a la exclusión.

7. Derechos de indemnización por daños y perjuicios

No nos responsabilizamos de los daños y perjuicios de todo tipo no previsibles en el momento de formalización del contrato con motivo de la no entrega o de la entrega con demora a causa de un incumplimiento de otras obligaciones contractuales, tampoco de la infracción de las obligaciones estipuladas en el momento de formalización del contrato, ni de los daños y perjuicios derivados de actos ilícitos. Esto no será aplicable cuando nosotros hubiéramos actuado con dolo o negligencia grave, cuando se trate de casos de comienzo de incapacidad o de la vulneración de una obligación esencial para el cumplimiento del efecto del contrato o de la vulneración de una obligación organizativa empresarial para evitar deficiencias de construcción, de fabricación y de uso.

8. Reserva de dominio

Los productos serán propiedad nuestra hasta el cumplimiento de todos los saldos deudores - en caso de pago por letra de cambio o de cheque, hasta que se efectúe el cobro - que el contratante/comprador/cliente nos adeude, independientemente de la causa jurídica. Además se nos concederán las siguientes garantías, que liberaremos previa petición a elección del comprador/cliente, siempre que su valor exceda las obligaciones de pago en más de un 15%. En tanto que fabricantes, el tratamiento y la transformación siempre nos corresponden de forma gratuita, sin ningún tipo de obligación para nosotros, de modo que conservamos el dominio de los productos en todo momento y en cualquier grado de transformación. El contratante/comprador/cliente custodiará nuestro dominio de forma gratuita. En caso de que el vendedor/comprador/cliente una/combine productos que no nos pertenecen y de ahí resulte una pérdida de dominio, se acuerda por el presente que la copropiedad resultante del contratante/comprador/cliente sobre la nueva cosa se nos transfiera por valor del importe de la factura final en relación con el valor del nuevo producto tras la transformación proporcional en el momento de la unión/combinación, y el

AGB Fortsetzung

Auftraggeber/Käufer/Besteller verpflichtet sich, unser Eigentum/Miteigentum mit der Sorgfalt eines ordentlichen Kaufmanns vor Verderb, Minderung oder Verlust zu bewahren, auch gegenüber seinen Auftraggebern/Käufern/Bestellern. Der Auftraggeber/Käufer/Besteller ist berechtigt, die Vorbehaltsware im ordnungsgemäßen Geschäftsverkehr zu verarbeiten und zu veräußern, solange er nicht im Verzug ist. Die aus dem Weiterverkauf oder einem sonstigen Rechtsgrund bezüglich der Vorbehaltsware entstehenden Forderungen, auch jede Art von Saldoforderungen, tritt er bereits jetzt sicherungshalber in vollem Umfang und mit allen Nebenrechten an uns ab. Wir ermächtigen ihn widerruflich, die uns abgetretenen Forderungen für eigene Rechnung und in eigenem Namen einzuziehen und den Erlös an uns bei Fälligkeit unserer Forderungen abzuführen. Ist die Einziehungsermächtigung widerrufen, so wird der Auftraggeber/Käufer/Besteller auf unsere Aufforderungen hin die Abtretung offen legen und uns die erforderlichen Auskünfte und Unterlagen zur Verfügung stellen. Verfügungen oder Sicherungsübereignungen der Vorbehaltsware sind unzulässig. Bei Zugriffen Dritter auf die Vorbehaltsware hat der Auftraggeber/Käufer/Besteller auf unser Eigentum hinzuweisen und uns unverzüglich zu benachrichtigen. Kosten und Schäden trägt der Auftraggeber/Käufer/Besteller. Bei vertragswidrigem Verhalten des Auftraggebers/Käufer/Bestellers, durch das der Wert der Ware als Sicherungsobjekt nicht unwesentlich gefährdet wird, sind wir berechtigt, die Vorbehaltsware nach Mahnung auf seine Kosten zurückzunehmen; der Auftraggeber/Käufer/Besteller ist zur Herausgabe verpflichtet. Die Geltendmachung des Eigentumsvorbehaltes sowie die Pfändung der Vorbehaltsware durch uns gilt nicht als Rücktritt vom Vertrag.

9. Zahlung

Alle Rechnungen sind innerhalb von 20 Tagen nach Rechnungsdatum ohne Abzug zu bezahlen. Bankgebühren gehen zu Lasten des Auftraggebers/Käufer/Bestellers. Alle Zahlungen sind direkt an uns zu leisten. Unsere Vertreter oder Reisenden sind nicht zum Inkasso berechtigt. Soweit der Auftraggeber/Käufer/Besteller keine besondere Nachricht gibt, werden Zahlungen jeweils auf die älteste offene Rechnung angerechnet. Eventuell gesondert schriftlich vereinbarte Skonti, die nur gewährt werden, wenn keine fälligen Rechnungen zur Bezahlung ausstehen, sind aus dem Rechnungsbruttobetrag zu ziehen, also aus der Summe aus Warenwert, Kosten für Nebenleistungen und Mehrwertsteuer. Gerät der Auftraggeber/Käufer/Besteller in Verzug, sind wir berechtigt, vom Eintritt des Verzuges an als Entschädigung ohne Nachweis Zinsen in Höhe von 2 % über dem jeweiligen Diskontsatz zuzüglich der gesetzlichen Mehrwertsteuer zu verlangen, unbeschadet unserer Möglichkeit, einen höheren tatsächlichen Schaden, insbesondere in Höhe des von den Geschäftsbanken üblicherweise berechneten Zinssatzes für offene Kontokorrentkredite, geltend zu machen. Kommt der Auftraggeber/Käufer/Besteller seinen Zahlungsverpflichtungen schuldhaft nicht nach, sind wir berechtigt, sofortige Bezahlung der insgesamt bestehenden Restschuld oder sicherheitshalber die einseitige Herausgabe der gelieferten Ware zu fordern, auch wenn wir Wechsel oder Schecks angenommen haben. Wir sind bei noch zu liefernden Waren außerdem berechtigt, Vorauszahlung oder zusätzliche Sicherheitsleistungen zu verlangen. Eine Zahlung gilt erst dann als erfolgt, wenn wir über den Betrag verfügen können, Zahlungen per Wechsel oder Scheck gelten erst nach endgültiger Einlösung als eingegangen. Sämtliche mit der Einziehung verbundenen Kosten gehen zu Lasten des Auftraggebers/Käufer/Bestellers. Für etwaige Nachteile wegen nicht formrichtigen oder rechtzeitigen Vorlegens oder Protesterhebung haften wir nur, wenn uns Vorsatz oder grobe Fahrlässigkeit zur Last fällt. Gegenüber

Terms and Conditions continuation

purchaser/orderer shall inform them of our ownership and notify us immediately. Costs and damages shall be borne by the customer/purchaser/orderer. In case of breach of contract on the part of the customer/purchaser/orderer by which the value of the goods as a security is not insignificantly endangered, we shall be authorised to take back upon reminder the reserved-title goods at his cost; the customer/purchaser/orderer shall be obligated to surrender the goods. Neither the assertion of title retention nor the pledging of the reserved-title goods shall constitute a withdrawal from the contract.

9. Payment

All invoices shall be payable in full within 20 days of the invoice date. Bank fees are to be paid by the customer/purchaser/orderer. All payments are to be made directly to us. Our representatives or travelling salespeople are not authorised to collect payment. Unless otherwise noted by the customer/purchaser/orderer, incoming payments shall be applied to the oldest unpaid invoice. Any special discounts agreed upon in writing, which are only granted if there are no outstanding invoices to be paid, are to be taken from the gross invoice amount, i.e. from the sum of the value of the goods, costs for additional services and value-added tax. If the customer/purchaser/orderer falls behind in payments, we shall be entitled to charge interest in the amount of 2% above the current discount rate plus the statutory value-added tax as compensation without proof from the time of default, regardless of the possibility to claim for higher actual damages, especially in the amount of the interest rate normally charged by commercial banks for overdrafts. If the customer/purchaser/orderer culpably does not meet his payment obligations, we shall be entitled to demand immediate payment of the entire outstanding balance or by way of security the provisional return of the supplied goods, even if we have accepted drafts or cheques. We shall furthermore be entitled to request advance payment or additional securities for goods not yet delivered. A payment shall be deemed effected when we can dispose of the amount; draft or cheque payments shall only be considered as being received upon final redemption. All costs incurred in the collection of payments shall be borne by the customer/purchaser/orderer. We shall only be liable for any disadvantages due to incorrect or untimely presentation or protest if we are charged with wilful or gross negligence. The customer/purchaser/orderer shall only be entitled to offset such claims against our payment demand which are undisputed by us or have been determined to be legally valid. The assertion of the right to retention is excluded. This pertains in particular to rights and demands derived from warranty claims.

10. Confidentiality

Unless otherwise expressly agreed in writing, the information provided to us in connection with orders shall not be regarded as confidential. Data made known to us during processing of the contract are stored in accordance with the applicable data protection laws.

11. Chemicals

Our chemical products, e.g. lubricants or sealants may only be used for commercial purposes by the customer or purchaser. They must not be given to private persons and must not be accessible to children or young people.

12. Data protection

The company may process and use the data recorded within the limits of the conclusion of the contract for execution of obligations under the contract. The company takes the measures necessary to secure the data in accordance with the legal regulations. The customer fully agrees to the storage and contractual use of his data by the company and is aware that

Condiciones generales continuación

contratante/comprador/cliente la custodiará de forma gratuita. El contratante/comprador/cliente se compromete a conservar nuestro dominio/copropiedad con la diligencia de un buen comerciante frente a su deterioro, reducción o pérdida, también frente a sus contratantes/compradores/clientes. El contratante/comprador/cliente está facultado a transformar o vender los productos de reserva en el marco de las actividades comerciales ordinarias siempre que no se haya retrasado en los pagos. Las obligaciones de pago que se originen de la reventa o por cualquier otra causa jurídica relacionada con los productos de reserva, también cualquier tipo de saldos deudores, nos las cederán en calidad de garantía ya ahora en toda su integridad y con todos los derechos accesorios. Le autorizamos de forma revocable a recaudar las obligaciones de pago que se nos han cedido por cuenta propia y en nombre propio, así como a entregarnos el importe al vencimiento de nuestras obligaciones. En caso de que se revoque la autorización, el contratante/comprador/cliente deberá dar a conocer públicamente a petición nuestra la cesión y poner a nuestra disposición la información y los documentos necesarios. Las daciones en prenda o las transmisiones en garantía de los productos de reserva no están permitidas. En caso de acceso de terceros a los productos de reserva, el contratante/comprador/cliente deberá hacer constar nuestro dominio e informarnos de inmediato. El contratante/comprador/cliente correrá con los costes y los daños y perjuicios. En caso de comportamiento contrario al contrato del contratante/comprador/cliente, por el cual el valor de los productos en tanto que objeto de cobertura se ponga en riesgo de forma considerable, estamos facultados (previa intimación) a retirar los productos de reserva por su cuenta; el contratante/comprador/cliente estará obligado a su devolución. La reivindicación de la reserva de dominio así como la pignoración de los productos de reserva por nuestra parte no será válida como desistimiento de contrato.

9. Pago

Todas las facturas deberán pagarse sin deducción dentro de los 20 días posteriores a la fecha de la factura. Las tasas bancarias correrán a cargo del contratante/comprador/cliente. Todos los pagos se nos abonarán directamente. Nuestros representantes no están autorizados a recibir cobros. Siempre y cuando el contratante/comprador/cliente no lo notifique en particular, los pagos se realizarán empezando por la factura pendiente más antigua. Los posibles descuentos acordados por escrito por separado, que solo se concederán cuando no existan facturas vencidas pendientes de pago, se extraerán del importe bruto de la factura, es decir, de la suma del valor de los productos, los costes por servicios accesorios y el IVA. En caso de que el contratante/comprador/cliente incurriese en mora, estaremos facultados para exigir, desde el inicio del retraso y como indemnización sin comprobante, intereses por valor de un 2% por encima del tipo de descuento correspondiente más el IVA vigente. Todo ello sin perjuicio de nuestra opción de reivindicar daños y perjuicios reales por un valor más elevado, en particular por el importe del interés que calculan habitualmente los bancos comerciales para créditos públicos de cuenta corriente. En caso de que el contratante/comprador/cliente no pudiese hacer frente por su culpa a sus obligaciones de pago, estaremos facultados a exigir el pago inmediato de la deuda pendiente íntegra o, por precaución, la devolución provisional de los productos entregados, incluso si hubiésemos aceptado letras de cambio o cheques. Además, en caso de productos que todavía no se hayan entregado, tendremos derecho a exigir un pago anticipado o garantías adicionales. Un pago se considerará abonado cuando podamos disponer del importe; los pagos por letra de cambio o cheque se considerarán realizados una vez hecho el cobro definitivo. Todos los costes vinculados al cobro correrán a cargo del contratante/comprador/cliente. En caso de posibles perjuicios a causa de una presentación o protesto que no se ajuste a la forma o impuntual, solo nos responsabilizaremos en caso de que nosotros hubiéramos actuado con dolo o

AGB Fortsetzung

unseren Zahlungsforderungen kann der Auftraggeber/Käufer/Besteller nur mit solchen Forderungen aufrechnen, die von uns unbestritten oder die rechtskräftig festgestellt sind. Die Geltendmachung von Zurückbehaltungsrechten ist ausgeschlossen. Dies gilt insbesondere auch für Rechte und Forderungen, die aus Gewährleistungsansprüchen hergeleitet werden.

10. Geheimhaltung

Falls nicht ausdrücklich schriftlich anders vereinbart, gelten die Informationen, die uns im Zusammenhang mit Bestellungen bekannt werden, nicht als vertraulich. Daten, die uns bei der Vertragsabwicklung zugänglich werden, werden im Sinne des jeweils anwendbaren Datenschutzgesetzes gespeichert.

11. Chemikalien

Unsere chemischen Produkte wie z.B. Schmierstoffe oder Abdichtmittel dürfen vom Auftraggeber/Käufer/Besteller nur für gewerbliche Zwecke verwendet werden. Sie dürfen nicht an Private abgegeben werden und dürfen nicht in die Hände von Kindern/Jugendlichen gelangen.

12. Datenschutz

Die Unternehmung darf die im Rahmen des Vertragschlusses aufgenommenen Daten zur Erfüllung der Verpflichtungen aus dem Vertrag verarbeiten und verwenden. Die Unternehmung ergreift die Maßnahmen, welche zur Sicherung der Daten gemäß den gesetzlichen Vorschriften erforderlich sind. Der Kunde erklärt sich mit der Speicherung und vertragsgemäßen Verwertung seiner Daten durch die Unternehmung vollumfänglich einverstanden und ist sich bewusst, dass die Unternehmung auf Anordnung von Gerichten oder Behörden verpflichtet und berechtigt ist, Informationen von Kunden diesen oder Dritten bekannt zu geben. Hat der Kunde es nicht ausdrücklich untersagt, darf die Unternehmung die Daten zu Marketingzwecken verwenden sowie für Werbezwecke an Ihre Partner weitergeben. Die zur Leistungserfüllung notwendigen Daten können auch an beauftragte Dienstleistungspartner oder sonstige Dritte weitergegeben werden.

Des Weiteren findet die Datenschutzerklärung Anwendung. Die Datenschutzerklärung ist auf der EXMAR Website zu finden.

13. Teilwirksamkeit

Auch bei rechtlicher Unwirksamkeit einzelner Punkte bleibt der Vertrag im Übrigen für beide Teile wirksam. Sollten im Übrigen einzelne der vorstehenden Bedingungen unwirksam oder aus einem sonstigen Grund nicht anwendbar sein, so bleiben die übrigen Bestimmungen gültig. Eine unwirksame Bestimmung ist durch eine entsprechende Regelung des dispositiven Rechts zu ersetzen.

14. Anwendbares Recht / Gerichtsstand

Erfüllungsort ist der Ort des Lieferwerks. Die Vertragsparteien vereinbaren die Anwendung des materiellen Rechts am Sitz des Lieferanten. Die Anwendbarkeit des UN Übereinkommens über den internationalen Warenkauf (WKR/CISG) wird ausdrücklich ausgeschlossen. Für mögliche bzw. allfällige Streitigkeiten aus diesem Vertrag vereinbaren die Parteien die Zuständigkeit der ordentlichen Gerichte am Sitz des Lieferanten. Der Lieferant ist jedoch berechtigt, den Auftraggeber/Käufer/Besteller an dessen Sitz zu belangen.

(Version 01/2020)

Terms and Conditions continuation

the company is obliged and entitled to disclose information from the customer to these or third parties at the order of courts or authorities. If the customer has not expressly forbidden it, the company may use the data for marketing purposes as well as pass it on to its partners for advertising purposes. The data necessary for performance may also be passed on to commissioned service partners or other third parties. Furthermore, the Data Protection Declaration applies. The Data Protection Declaration can be found on the EXMAR website.

13. Partial invalidity

The legal invalidity of individual points shall not affect the validity of the remainder of the contract for both parties. Also should any of the mentioned provisions be invalid or not applicable for any other reason, the rest of the provisions shall remain valid. An invalid provision shall be replaced by a corresponding regulation of non-mandatory law.

14. Applicable law / Place of jurisdiction

The place of performance shall be the location of the supplying plant. The parties to the contract agree to apply the substantive law at the domicile of the Supplier. The applicability of the UN Convention on Contracts for the International Sales of Goods (WKR/CISG) is expressly excluded. For any possible disputes arising from this contract the parties agree to the jurisdiction of the ordinary courts at the domicile of the Supplier. The Supplier is however entitled to take legal action against the customer/purchaser/orderer at his place of business.

(Version 01/2020)

Condiciones generales continuación

negligencia grave. Frente a nuestras obligaciones de pago, el contratante/comprador/cliente solo podrá compensar aquellas obligaciones que hayamos establecido de forma indiscutida o que se hayan establecido judicialmente. Queda excluida la reivindicación del embargo. Esto será en especial de aplicación también para los derechos y las obligaciones derivados de reclamaciones de garantía.

10. Confidencialidad

En caso de que no se acuerde por escrito algo distinto, la información que se nos dé a conocer en relación con los pedidos no será confidencial. Los datos a los que se nos dé acceso durante la tramitación del contrato se almacenarán en virtud de la ley de protección de datos aplicable en ese momento.

11. Sustancias químicas

El uso de nuestros productos químicos, p. ej., lubricantes o selladores, por el contratante/comprador/cliente debe limitarse a aplicaciones industriales. No entregar a particulares y mantener fuera del alcance de niños y jóvenes.

12. Protección de datos

La empresa podrá tratar y utilizar, con el fin de cumplir sus obligaciones contractuales, los datos recogidos con motivo de la celebración del contrato. La empresa adoptará las medidas necesarias para asegurar los datos conforme a la normativa aplicable. El cliente declara su plena conformidad con el almacenamiento y el uso de sus datos con arreglo al contrato por parte de la empresa y es consciente de que, a requerimiento de las autoridades judiciales o administrativas, la empresa estará obligada y facultada para transmitir a dichas autoridades o a terceros información sobre el cliente. Salvo prohibición expresa por el cliente, la empresa podrá utilizar los datos con fines comerciales y los podrá transmitir a sus socios con fines publicitarios. Los datos necesarios para la prestación de los servicios también podrán ser transmitidos al proveedor a quien se haya encomendado dicha prestación o a otros terceros.

Por lo demás, se aplicará la declaración sobre protección de datos, que se encuentra disponible en el sitio web del grupo SERTO.

13. Validez parcial

Incluso en el caso de que aspectos individuales resulten ineficaces jurídicamente, el contrato seguirá siendo por lo demás válido para las dos partes.

Si por lo demás algunas de las condiciones anteriores resultara ineficaz individualmente o no pudiera aplicarse por cualquier otro motivo, el resto de disposiciones seguirán siendo vigentes. Una disposición ineficaz deberá sustituirse por una reglamentación adecuada de derecho dispositivo.

14. Derecho aplicable / jurisdicción

El lugar de cumplimiento será el lugar de la fábrica proveedora. Las partes contratantes acuerdan la aplicación del derecho material de la sede del Proveedor. Queda excluida explícitamente la aplicabilidad de la Convención de las Naciones Unidas sobre los contratos de compraventa internacional de mercaderías (CISG). En caso de posibles desacuerdos derivados del presente contrato, las partes convienen en la competencia de los tribunales ordinarios de la sede del Proveedor. No obstante, el Proveedor tendrá derecho a demandar al contratante/comprador/cliente en la sede de éste.

En caso de duda, la versión alemana será obligatorio.

(Versión 01/2020)



Zertifizierungen gelten für unsere Edelstahl-Verschraubungen.
Entsprechende Zertifikate finden Sie auf unserer Website www.exmar.de.

Certifications apply to our stainless steel tube fittings.
Corresponding certificates can be found on our website www.exmar.de/en.

Los certificaciones se aplican a nuestros racores de conexión en acero inoxidable. Certificados correspondientes se pueden encontrar en nuestro sitio web www.exmar.de/en.

Umfangreiche Ingenieur-Erfahrung verbunden mit kontinuierlicher Produktneu- und Weiterentwicklung bilden die Grundlage für höchste Qualität. Unsere Produkte sind baumustergeprüft und wurden von den wichtigsten nationalen und internationalen Abnahmegesellschaften zugelassen.

Extensive engineering experience combined with continual innovation and further developments are the basis for the outstanding quality of our products and services. Our products are type-tested and approved by the most important national and international certification institutes.

La amplia experiencia de nuestros ingenieros y la creación y evolución incesante de productos son argumentos que permiten alcanzar la máxima calidad. Nuestros productos están homologados y han sido aprobados a escala nacional e internacional por los principales organismos de normalización.

Nachdruck, auch auszugsweise, nur mit schriftlicher Genehmigung der EXMAR GmbH.
Sämtliche Angaben vermitteln technische Informationen und enthalten keine Garantiezusagen. Technische Änderungen vorbehalten. Siehe auch Allgemeine Geschäftsbedingungen.

Reprint, including extracts, requires the written consent of EXMAR GmbH.
All the data are for the purpose of providing technical information and do not constitute any warranty. Technical data are subject to change. Please see our General Terms and Conditions of Sale.

Prohibida la reproducción total o parcial sin la autorización escrita de EXMAR GmbH. La información de este documento tiene exclusivamente carácter técnico y no contiene declaraciones de garantía. Se reserva el derecho a realizar modificaciones técnicas. Véanse también las condiciones de venta generales.

EXMAR

Hochwertig

Sie können sich auf uns verlassen. Wir garantieren Ihnen höchste Qualität. Für unsere Produkte verwenden wir ausschließlich hochwertigen Edelstahl (1.4571), unsere Verbindungen sind baumustergeprüft und verfügen über die branchenrelevanten Zulassungen.

High quality

You can depend on us. We guarantee maximum quality and use only superior quality stainless steel (AISI 316Ti). Our connections are type-tested and certified according to international standards.

Calidad puntera

Puede confiar en nosotros. Le garantizamos la máxima calidad. Para nuestros productos utilizamos exclusivamente acero inoxidable de alta calidad (AISI 316Ti); nuestras uniones están homologadas y tienen las aprobaciones pertinentes del sector.

Flexibel

Optimieren Sie Ihre Lagerbestände und nutzen Sie die hohe Verfügbarkeit unserer Produkte. Ihre kurzfristigen Wünsche erfüllen wir ebenso gerne, wie wir mit pünktlicher Lieferung dafür sorgen, dass Ihre Produktion reibungslos weiterläuft.

Flexible

Optimise your inventory. Our readily available products and prompt delivery service enable the smooth running of your production processes.

Flexibilidad

Optimice sus existencias y benefíciese de la alta disponibilidad de nuestros productos. Atendemos sus pedidos urgentes con la misma diligencia con la que suministramos puntualmente la mercancía para que pueda mantener el ritmo de producción.

Individuell

Ihre Fragen zu technischen Anforderungen werden von unseren Spezialisten kompetent beantwortet. Durch eine eigene technische Entwicklung verfügen wir über ein hohes fachliches Know-how. Gerne erarbeiten wir für Sie speziell auf Ihre Bedürfnisse zugeschnittene Systemlösungen und Sonderanfertigungen.

Individual

Your technical questions are answered competently by our specialists. Our in-house development team has extensive know-how, which they are glad to share with you in developing products made to your specifications as well as custom-made system solutions.

Personalización

Nuestros competentes especialistas contestarán sus preguntas sobre los requisitos técnicos. El hecho de disponer de un departamento de desarrollo técnico propio nos aporta amplios conocimientos especializados. Podemos elaborar soluciones de sistema y acabados especiales adaptados a sus necesidades a petición.

EXMAR GmbH

Am Taubenbaum 6, D-61231 Bad Nauheim, Tel. +49 (0)60 32 / 86986-0, Fax +49 (0)60 32 / 86986-13, info@exmar.de

www.exmar.de